

# Vacuum Saving Valve

New

## Can avoid the loss of pressure even when there is no work piece.

When multiple vacuum pads are operated by one vacuum generator, and some of them are not holding the work piece, the vacuum pressure is restricted and the work piece can remain held by the rest of pads.

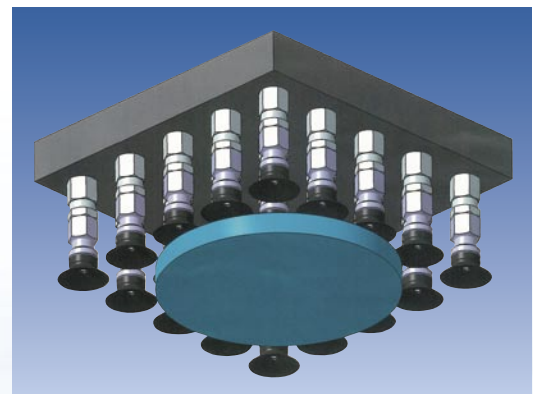
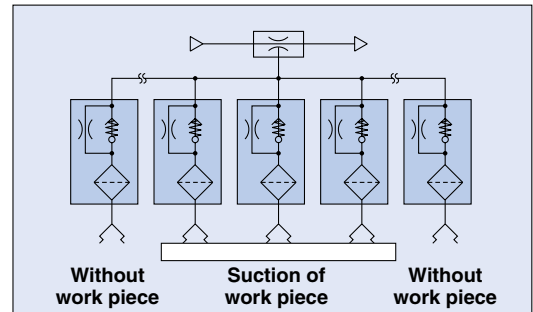

## No need of switching operation when changing work pieces

When the work pieces have different shapes, the control circuit can be simplified.

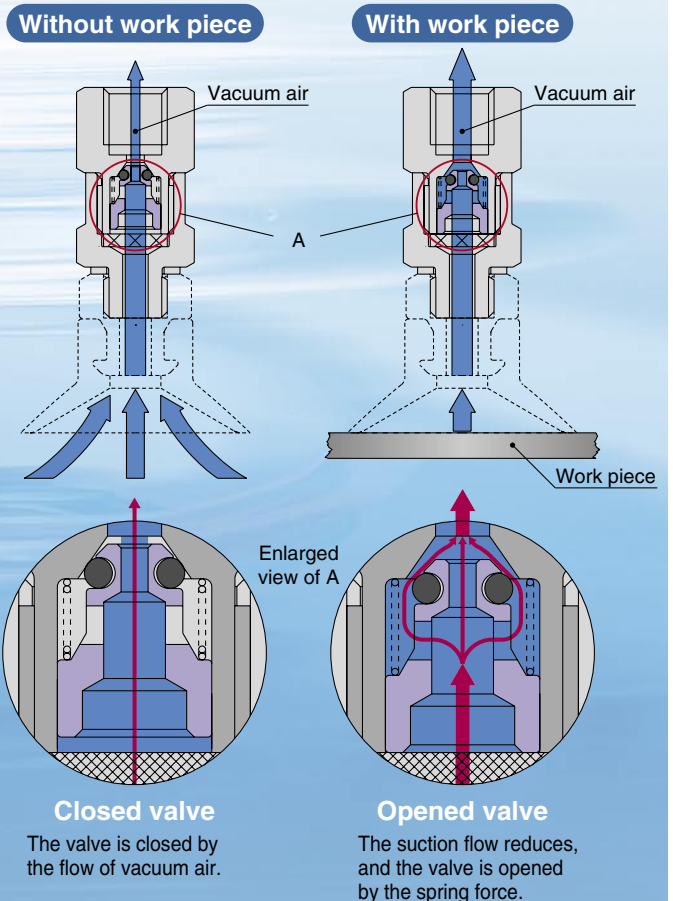
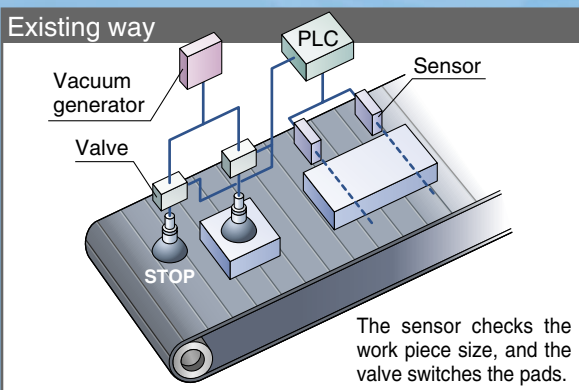
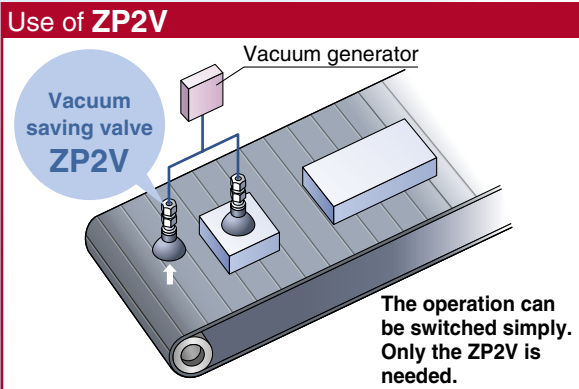

Series ZP2V



CAT.EUS100-81A-UK

# Vacuum Saving Valve Series ZP2V Model Selection

Select the quantity of vacuum saving valves that can be used with one vacuum generator.

## Selection Conditions

**Work piece:** No leakage and several sizes  
**Required vacuum pressure:** -50 kPa or more of vacuum pressure per vacuum pad  
**Part number of the vacuum saving valve used:** ZP2V-A8-05  
**(Connection thread size for the pad: M8, Fixed orifice size:  $\phi$ 0.5)**

### 1 Check the flow-rate characteristics of the vacuum generator used.

From the flow-rate characteristics of the vacuum generator (**Chart 1**), calculate the **suction flow (Q1)** of the vacuum generator for a required vacuum pressure.

Vacuum pressure -50 kPa (①→②→③) =  
**Suction flow (Q1)  $\approx$  31  $\ell$ /min (ANR).**

**Chart 1. Flow-rate Characteristics of Vacuum Generator**

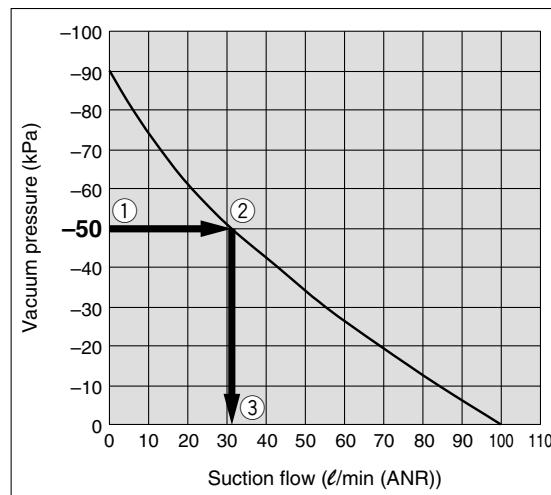

### 2 Calculate the quantity (N) of vacuum saving valves.

Find the **minimum operating flow (Q2)** and the **suction flow (Q1)** of the vacuum generator from the specifications table (page 1), and calculate the **quantity (N)** of vacuum saving valves that can be used with one vacuum generator.

$$\text{Quantity of vacuum saving valves (N)} = \frac{\text{Suction flow of the vacuum generator (Q1)}}{\text{Minimum operating flow (Q2)}}$$

Example) Vacuum saving valve used: ZP2V-A8-05  
 From **Table 1**, Q2 can be calculated as 5.0  $\ell$ /min (ANR).

$$N = \frac{31 \{ \ell/\text{min (ANR)} \}}{5 \{ \ell/\text{min (ANR)} \}} \approx 6 \text{ (unit)}$$

**Table 1. Relationship between the Minimum Operating Flow and the Fixed Orifice Size**

Connection thread size for the pad	M8
Fixed orifice size (mm)	0.5
Minimum operating flow ( $\ell$ /min (ANR)) Q2	5.0

**Chart 2. Example of Selection of the Minimum Operating Flow**

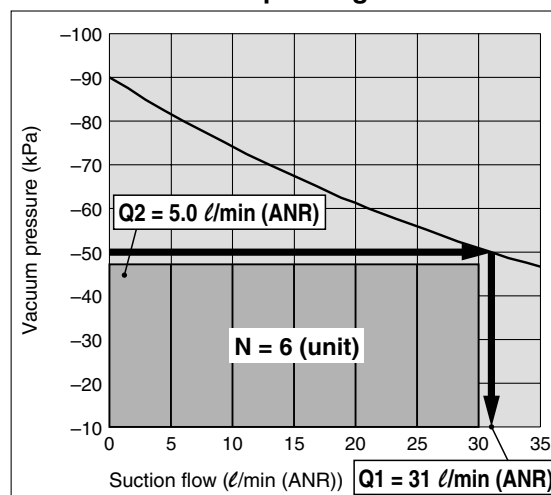

The selection example above is based on a general method under the given selection conditions, and may not always be applicable. A final decision on the operating conditions should be made based on test results performed under the responsibility of the customer.

# Vacuum Saving Valve

## Series ZP2V

### How to Order



ZP2V - **A5** - **03**

Connection thread symbol for the pad ●

#### Male thread connection

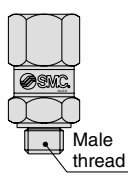
Symbol	Thread size	Applicable fixed orifice size				 Male thread Pad side
		0.3	0.5	0.7	1.0	
<b>A5</b>	M5	○	○	○	—	
<b>A8</b>	M8	—	○	○	○	
<b>A01</b>	R1/8	—	○	○	○	
<b>AG1</b>	G1/8	—	○	○	○	
<b>AN1</b>	NPT1/8	—	○	○	○	

● Fixed orifice size

Symbol	Fixed orifice size (mm)
<b>03</b>	0.3
<b>05</b>	0.5
<b>07</b>	0.7
<b>10</b>	1.0

#### Female thread connection

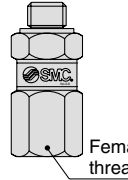
Symbol	Thread size	Applicable fixed orifice size				 Female thread Pad side
		0.3	0.5	0.7	1.0	
<b>B5</b>	M5	○	○	○	—	
<b>B6</b>	M6	○	○	○	—	
<b>B01</b>	Rc1/8	—	○	○	○	
<b>BG1</b>	G1/8	—	○	○	○	
<b>BN1</b>	NPT1/8	—	○	○	○	

## Specifications

Connection thread size for the pad	M5, M6			M8, R1/8, G1/8, NPT1/8		
Fixed orifice size (mm)	0.3	0.5	0.7	0.5	0.7	1.0
Fluid	Air					
Max. operating pressure range (MPa)	0 to 0.7					
Max. operating vacuum pressure range (kPa)	0 to -100					
Ambient and fluid temperature (°C)	5 to 60 (No freezing)					
Element nominal filtration rating (μm)	40					
Minimum operating flow (ℓ/min (ANR))	3	5	8	5	8	16

# Series ZP2V

## Working Principle

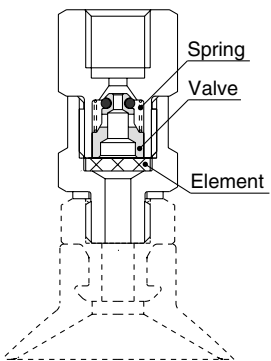
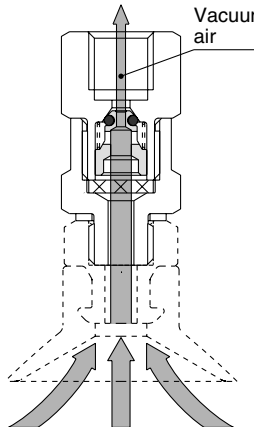
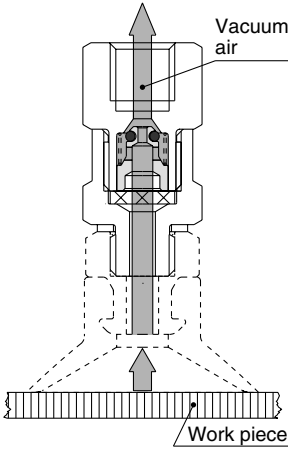
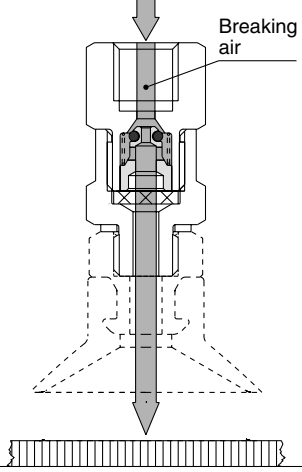
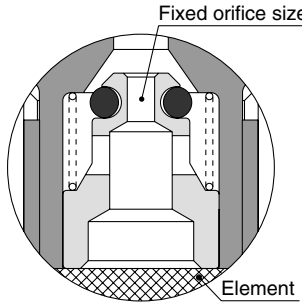
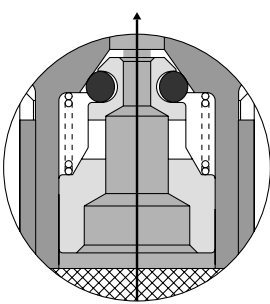
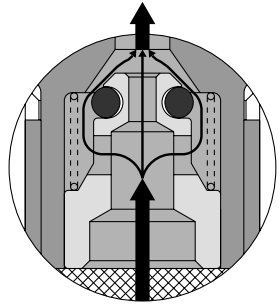
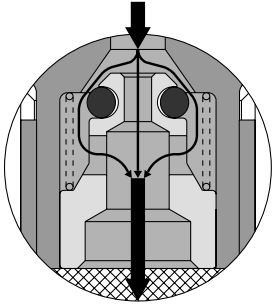
	Initial condition	When a work piece is sucked		When a work piece is released
		Without work piece	With work piece	
Air flow				
Valve operating condition	 <p>Fixed orifice size</p> <p>Element</p> <p>Since there is no air flow, the valve remains open by the spring force.</p>	 <p><b>Closed valve</b></p> <p>When the work piece is separated from the vacuum pad, the valve is closed by the air flow, and the suction air can only flow through the fixed orifice. At this time, an amount of air corresponding to the fixed orifice size is sucked.</p>	 <p><b>Open valve</b></p> <p>When the work piece is sucked by the vacuum pad, the suction flow reduces, and the valve is opened by the spring force, which opens the path between the valve and body for suction.</p>	 <p><b>Open valve</b></p> <p>When the work piece is released, the valve is opened by the vacuum breaking air, and the path between the valve and body will open.</p>

## Construction

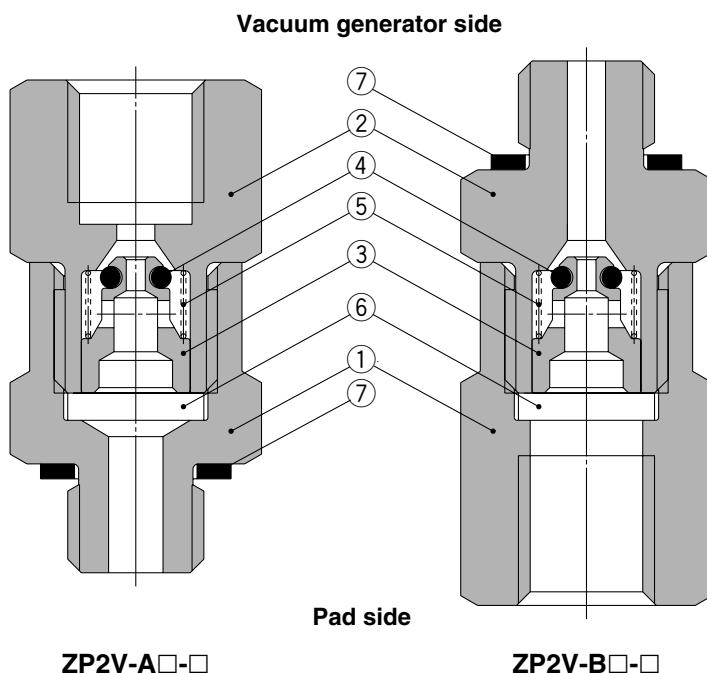

ZP2V-A□-□

ZP2V-B□-□

Vacuum generator side

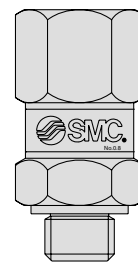

Pad side

\* For the direction of the product, refer to point 4 in back page 3.

### Component Parts

No.	Description	Material	Surface treatment
1	Body A	Brass	Electroless nickel plated
2	Body B	Brass	Electroless nickel plated
3	Valve	Aluminum	—
4	O-ring	HNBR	—
5	Spring	Stainless steel	—
6	Element	Bronze (CAC403) or equivalent	—
7	Gasket	NBR + Stainless steel	—

## Dimensions

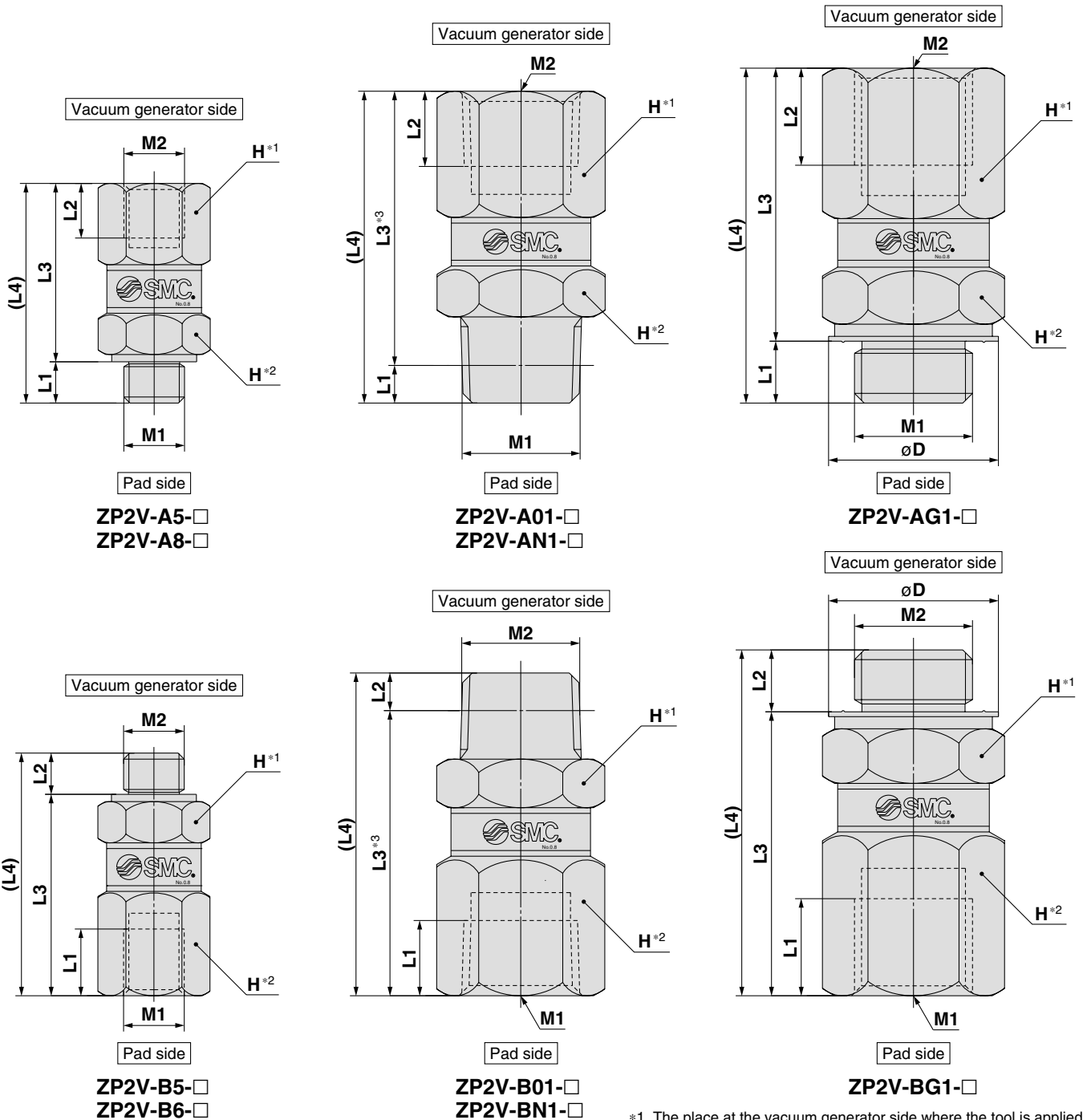

\*1 The place at the vacuum generator side where the tool is applied.

\*2 The place at the pad side where the tool is applied.

\*3 Referential dimensions after the R, NPT thread is screwed.

(mm)

Model	M1	M2	L1	L2	L3	L4	H (Width across flats)	øD	W (g)	Tightening torque (N·m) <small>Note)</small>
ZP2V-A5-□	M5 x 0.8	M5 x 0.8	3.4	4.5	14.7	18.1	8	—	6	1.0 to 1.5
ZP2V-A8-□	M8 x 1.25	M8 x 1.25	5.9	8	20.1	26	12	—	18	5.5 to 6.0
ZP2V-A01-□	R1/8	Rc1/8	3.1	6.2	22.6	25.7	12	—	18	7.0 to 9.0
ZP2V-AG1-□	G1/8	G1/8	5.1	8	22.5	27.6	13	14	23	5.5 to 6.0
ZP2V-AN1-□	NPT1/8	NPT1/8	3.2	6.9	23.3	26.5	12	—	23	7.0 to 9.0
ZP2V-B5-□	M5 x 0.8	M5 x 0.8	5.5	3.4	16.6	20	8	—	7	1.0 to 1.5
ZP2V-B6-□	M6 x 1	M6 x 1	5	4.5	16.2	20.7	8	—	7	2.0 to 2.5
ZP2V-B01-□	Rc1/8	R1/8	6.2	3.1	23.5	26.6	12	—	19	7.0 to 9.0
ZP2V-BG1-□	G1/8	G1/8	8	5.1	23.4	28.5	13	14	24	5.5 to 6.0
ZP2V-BN1-□	NPT1/8	NPT1/8	6.9	3.2	24.2	27.4	12	—	20	7.0 to 9.0



Note) When mounting and removing the product, apply a wrench or torque wrench to the place shown in the Figure.  
When mounting, tighten to the torque specified in the table.



# Safety Instructions

These safety instructions are intended to prevent hazardous situations and/or equipment damage. These instructions indicate the level of potential hazard with the labels of “**Caution,**” “**Warning**” or “**Danger.**” They are all important notes for safety and must be followed in addition to International Standards (ISO/IEC)<sup>Note 1)</sup>, and other safety regulations.

Note 1) ISO 4414: Pneumatic fluid power – General rules relating to systems.  
ISO 4413: Hydraulic fluid power – General rules relating to systems.  
IEC 60204-1: Safety of machinery – Electrical equipment of machines. (Part 1: General requirements)  
ISO 10218: Manipulating industrial robots - Safety.  
etc.

-  **Caution:** **Caution** indicates a hazard with a low level of risk which, if not avoided, could result in minor or moderate injury.
-  **Warning:** **Warning** indicates a hazard with a medium level of risk which, if not avoided, could result in death or serious injury.
-  **Danger :** **Danger** indicates a hazard with a high level of risk which, if not avoided, will result in death or serious injury.

## Warning

### 1. The compatibility of the product is the responsibility of the person who designs the equipment or decides its specifications.

Since the product specified here is used under various operating conditions, its compatibility with specific equipment must be decided by the person who designs the equipment or decides its specifications based on necessary analysis and test results. The expected performance and safety assurance of the equipment will be the responsibility of the person who has determined its compatibility with the product. This person should also continuously review all specifications of the product referring to its latest catalogue information, with a view to giving due consideration to any possibility of equipment failure when configuring the equipment.

### 2. Only personnel with appropriate training should operate machinery and equipment.

The product specified here may become unsafe if handled incorrectly. The assembly, operation and maintenance of machines or equipment including our products must be performed by an operator who is appropriately trained and experienced.

### 3. Do not service or attempt to remove product and machinery/equipment until safety is confirmed.

1. The inspection and maintenance of machinery/equipment should only be performed after measures to prevent falling or runaway of the driven objects have been confirmed.
2. When the product is to be removed, confirm that the safety measures as mentioned above are implemented and the power from any appropriate source is cut, and read and understand the specific product precautions of all relevant products carefully.
3. Before machinery/equipment is restarted, take measures to prevent unexpected operation and malfunction.

### 4. Contact SMC beforehand and take special consideration of safety measures if the product is to be used in any of the following conditions.

1. Conditions and environments outside of the given specifications, or use outdoors or in a place exposed to direct sunlight.
2. Installation on equipment in conjunction with atomic energy, railways, air navigation, space, shipping, vehicles, military, medical treatment, combustion and recreation, or equipment in contact with food and beverages, emergency stop circuits, clutch and brake circuits in press applications, safety equipment or other applications unsuitable for the standard specifications described in the product catalogue.
3. An application which could have negative effects on people, property, or animals requiring special safety analysis.
4. Use in an interlock circuit, which requires the provision of double interlock for possible failure by using a mechanical protective function, and periodical checks to confirm proper operation.



# Safety Instructions

## Caution

### 1. The product is provided for use in manufacturing industries.

The product herein described is basically provided for peaceful use in manufacturing industries.

If considering using the product in other industries, consult SMC beforehand and exchange specifications or a contract if necessary.

If anything is unclear, contact your nearest sales branch.

## Limited warranty and Disclaimer/Compliance Requirements

The product used is subject to the following “Limited warranty and Disclaimer” and “Compliance Requirements”. Read and accept them before using the product.

### Limited warranty and Disclaimer

1. The warranty period of the product is 1 year in service or 1.5 years after the product is delivered.\*2)

Also, the product may have specified durability, running distance or replacement parts. Please consult your nearest sales branch.

2. For any failure or damage reported within the warranty period which is clearly our responsibility, a replacement product or necessary parts will be provided.

This limited warranty applies only to our product independently, and not to any other damage incurred due to the failure of the product.

3. Prior to using SMC products, please read and understand the warranty terms and disclaimers noted in the specified catalogue for the particular products.

**Note 2) Vacuum pads are excluded from this 1 year warranty.**

A vacuum pad is a consumable part, so it is warranted for a year after it is delivered.

Also, even within the warranty period, the wear of a product due to the use of the vacuum pad or failure due to the deterioration of rubber material are not covered by the limited warranty.

### Compliance Requirements

1. The use of SMC products with production equipment for the manufacture of weapons of mass destruction (WMD) or any other weapon is strictly prohibited.

2. The exports of SMC products or technology from one country to another are governed by the relevant security laws and regulations of the countries involved in the transaction. Prior to the shipment of a SMC product to another country, assure that all local rules governing that export are known and followed.



# Series ZP2V

## Specific Product Precautions

Be sure to read before handling.

Refer to back pages 1 and 2 for Safety Instructions, "Handling Precautions for SMC Products" (M-E03-3) for Vacuum Equipment Precautions.

1. The product is not equipped with a vacuum holding function, and cannot be used for the purpose of holding vacuum.
2. Determine the quantity of products to be used by selection, and keep the recommended pad diameter per product shown in Table 1. Also, check the operation with the customer's machine sufficiently before using.

Table 1. Recommended Pad Diameter per Product

Connection thread symbol for the pad	A5	B5	B6	A8	A01	B01	AG1	BG1	AN1	BN1
Thread size	M5		M6	M8	R1/8		G1/8		NPT1/8	
Recommended pad diameter (mm)	25 or less			32 to 50						

3. Do not disassemble the product. Once the product is disassembled and reassembled, it will not be able to satisfy the original performance.
4. When piping, do not get the pad side and vacuum generator side of the product the wrong way round. (Refer to Fig. 1.)

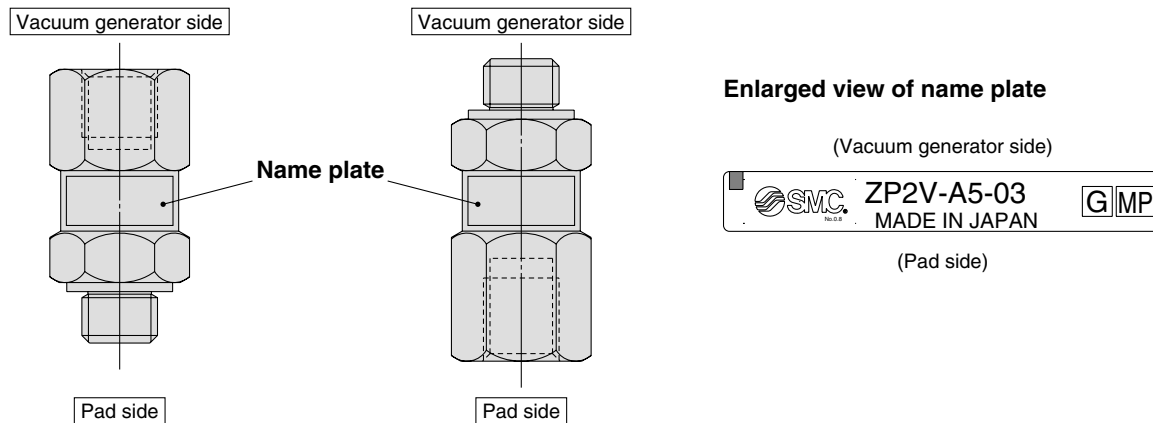

Fig. 1. Mounting direction

5. For mounting and removing the product, strictly follow the instructions below.  
When mounting and removing the product, use the specified parts of the product shown in page 3 to apply tools. Also, when mounting, tighten to the specified torque shown in page 3. Excessive torque or applying a tool to parts other than the specified can cause damage or loss of the original performance.
6. The reduction of the vacuum pressure while the work piece is sucked and released depends on the flow-rate characteristics of the vacuum generator. Check the flow-rate characteristics of the vacuum generator, and then confirm the operation with the customer's machine.
7. When the built-in element of the product gets clogged, replace the whole product.
8. If the suction is checked by a pressure sensor, check the operation with the customer's machine sufficiently beforehand.
9. If there is leakage between the pad and work piece, for example if the work piece is permeable, the quantity of products that can be used with one vacuum generator is reduced.  
Take the leakage between the pad and work piece into account and check the operation with the customer's machine sufficiently before using.

Safety Instructions	Be sure to read "Handling Precautions for SMC Products" (M-E03-3) before using.
---------------------	---