



Differs depending on the voltage and electrical entry. For details, refer to table 8 below.

# Direct Operated 2-Port Solenoid Valve

## JSX Series



Refer to page 9 for details.



### How to Order



**JSX** **2** **1** - **S** **N** **302** **F** - **5** **G** - **B**

1 2 3 4 5 6 7 8 9

#### 1 Size

Symbol	Series
1	10
2	20
3	30

#### 2 Valve type

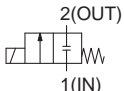
Symbol	Valve type
1	N.C. 







#### 3 Body material

Symbol	Body material
S	Stainless steel

#### 4 Seal material

Symbol	Seal material
N	NBR
F	FKM
E	EPDM

#### 8 Electrical entry

Symbol	Electrical entry	Image	Series			Rated voltage	UL Standards
			10	20	30		
G	Grommet*1		●	●	●	5 6	Refer to page 9.
GS	Grommet with PCB (With surge voltage suppressor)		●	●	●	1 5 6 8 B	
CS	Conduit (With surge voltage suppressor)		—	●	●	All voltages	
DS	DIN terminal (With surge voltage suppressor)		●	●	●	All voltages	
DZ	DIN terminal with light (With surge voltage suppressor)		●	●	●	All voltages	
DN	Without DIN connector (With surge voltage suppressor)		●	●	●	All voltages	

#### 5 Orifice diameter and port size

Symbol	Orifice diameter [mm Ø]	Port size	Series		
			10	20	30
101	1.6	1/8	●	—	—
201	2.4	1/8	●	—	—
301	3.2	1/8	—	●	—
302		1/4	—	●	—
303	3/8	—	●	—	
402	4	1/4	—	●	●
403		3/8	—	●	●
502	5.6	1/4	—	●	●
503		3/8	—	●	●
702	7.1	1/4	—	●	●
703		3/8	—	●	●

#### 7 Rated voltage

Symbol	Rated voltage	Symbol	Rated voltage	Symbol	Rated voltage
1	100 VAC	5	24 VDC	B	24 VAC
2	200 VAC	6	12 VDC	J	230 VAC
3	120 (110) VAC	7	240 VAC		
4	220 VAC	8	48 VAC		

#### 9 Option

Symbol	Option
—	None
B	With bracket*1 (Stainless steel)

\*1 DC voltage only

\*1 Bracket assembly part nos. (page 17)

### Flow Rate Characteristics

Series	Port size	Orifice diameter [mm Ø]	Flow rate characteristics*1							Max. operating pressure differential [MPa]	Model	Weight*2 [g]
			Air			Water, Oil						
			C [dm <sup>3</sup> /(s·bar)]	b	Cv	Kv	Conversion Cv					
10	1/8	1.6	0.36	0.58	0.08	0.07	0.08	0.9		JSX11-S□101	160	
		2.4	0.62	0.45	0.15	0.13	0.15	0.4		JSX11-S□201	160	
20	1/8	3.2	1.35	0.48	0.35	0.30	0.35	0.7		JSX21-S□301	320	
		3.2	1.35	0.48	0.35	0.30	0.35	0.7		JSX21-S□302	320	
		4.0	2.02	0.48	0.52	0.45	0.52	0.3		JSX21-S□402	320	
		5.6	2.62	0.43	0.73	0.63	0.73	0.2		JSX21-S□502	320	
	3/8	7.1	3.15	0.44	0.88	0.76	0.88	0.1		JSX21-S□702	320	
		3.2	1.35	0.48	0.35	0.30	0.35	0.7		JSX21-S□303	320	
		4.0	2.02	0.48	0.52	0.45	0.52	0.3		JSX21-S□403	320	
		5.6	2.62	0.43	0.73	0.63	0.73	0.2		JSX21-S□503	320	
30	1/4	7.1	3.15	0.44	0.88	0.76	0.88	0.1		JSX21-S□703	320	
		4.0	2.02	0.48	0.52	0.45	0.52	1.0		JSX31-S□402	450	
		5.6	2.62	0.43	0.73	0.63	0.73	0.5		JSX31-S□502	450	
	3/8	7.1	3.15	0.44	0.88	0.76	0.88	0.2		JSX31-S□702	450	
		4.0	2.02	0.48	0.52	0.45	0.52	1.0		JSX31-S□403	450	
		5.6	2.62	0.43	0.73	0.63	0.73	0.5		JSX31-S□503	450	
		7.1	3.15	0.44	0.88	0.76	0.88	0.2		JSX31-S□703	450	

\*1 The flow rate characteristics of this product have variations.

\*2 The values were calculated based on the combination of Rc, NPT thread, and grommet. Add 30 g for G thread (port size 3/8).

Add 20 g for grommet with PCB, 70 g for conduit, and 50 g for DIN terminal.

### Applicable Fluid Check List

Applicable fluid	Seal material*2		
	NBR	FKM	EPDM
Air	●	●	●
Water	●	●	●
Oil	—	●	—

\* The list shows the compatibility between general fluids and seal materials. Consider the operating environment and application sufficiently before selecting the seal material. Fluid and component compatibility should be checked in the application before use. If something is not clear, please contact SMC.

## Construction

### 10 series, Normally closed (N.C.)

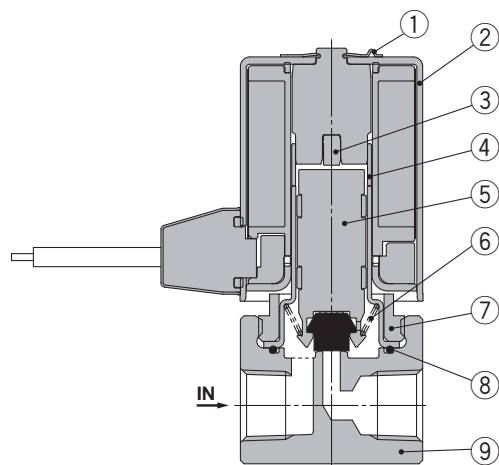

#### Component Parts

No.	Description	Material
1	Clip	Stainless steel
2	Solenoid coil	Stainless steel, Cu, Resin
3	Stopper	PPS
4	Tube assembly	Stainless steel
5	Armature assembly	Stainless steel, PPS, NBR, FKM, EPDM
6	Spring	Stainless steel
7	Set nut	Stainless steel
8	Gasket	NBR, FKM, EPDM
9	Body	Stainless steel

### 20/30 series, Normally closed (N.C.)

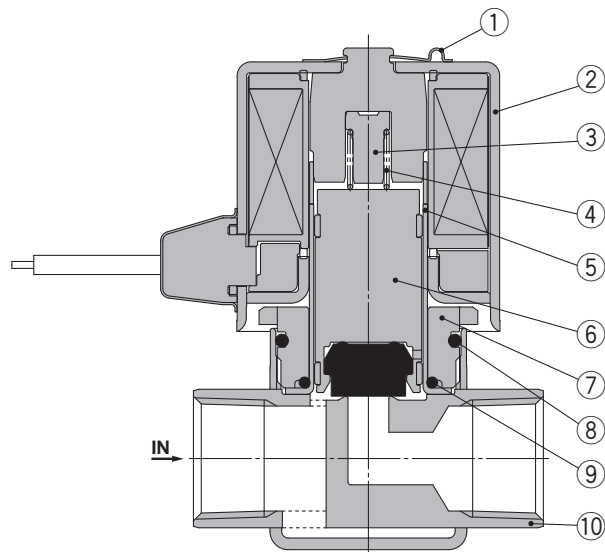

#### Component Parts

No.	Description	Material
1	Clip	Stainless steel
2	Solenoid coil	Stainless steel, Cu, Resin
3	Stopper	PPS
4	Spring	Stainless steel
5	Tube assembly	Stainless steel
6	Armature assembly	Stainless steel, PPS, NBR, FKM, EPDM
7	Nut	Stainless steel
8	Gasket	NBR, FKM, EPDM
9	Gasket	NBR, FKM, EPDM
10	Body	Stainless steel

## Common Specifications

Series		10	20	30	
Valve specifications	Valve construction	Direct operated poppet			
	Valve type	Normally closed (N.C.)			
	Fluid and fluid temperature	Air : -10 to 60 °C (Dew point temperature: -10 °C or less) Water: 1 to 60 °C (No freezing) Oil : -5 to 60 °C (Kinematic viscosity: 50 mm <sup>2</sup> /s or less)			
	Withstand pressure	2.0 MPa			
	Max. system pressure	1.0 MPa			
	Ambient temperature	-20 to 60 °C			
	Valve leakage*1	Air	1 cm <sup>3</sup> /min or less		
		Water, Oil	0.1 cm <sup>3</sup> /min or less		
	Enclosure*2	IP67 (IP65 for the DIN connector)			
	Standards*3	CE, UL Recognised, UL Listed			
Operating environment	Location without the presence of corrosive gases, explosive gases, or constant fluid adhesion				
Body material	Stainless steel				
Seal material	NBR, FKM, EPDM				
Coil specifications	Rated voltage	AC	24 V, 48 V, 100 V, 110 V, 120 V, 200 V, 220 V, 230 V, 240 V		
		DC	12 V, 24 V		
	Allowable voltage fluctuation	± 10 % of rated voltage			
	Allowable leakage voltage	AC	5 % or less of rated voltage		
		DC	2 % or less of rated voltage		
	Apparent power*4, *5	AC	4.5 VA	8 VA	9.5 VA
Power consumption*4	DC	4 W	6 W	8 W	
Temperature rise*6	65 °C				

\*1 Valve leakage: The value at a temperature of 20 °C

\*2 This product ensures IP67, but if water enters the product, it may result in operation failure or breakage.

Therefore, take appropriate measures to prevent water from entering the product when used in an environment where it is constantly exposed to water.

\*3 Conformance to standards varies depending on the model. For details, refer to pages 3 and 9.

\*4 Power consumption/Apparent power: The value at an ambient temperature of 20 °C and when the rated voltage is applied (Variation: ± 10 %)

\*5 There is no difference in the frequency and the inrush and energized apparent power, since a rectifying circuit is used in the AC.

\*6 Temperature rise: The value at an ambient temperature of 20 °C and when the rated voltage is applied. The value depends on the ambient environment. This is for reference.

**Be sure to read "Specific Product Precautions" before handling.**

# JSX Series

## Dimensions: 10 Series



### G: Grommet

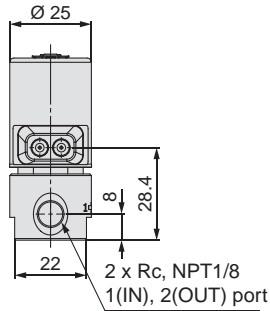
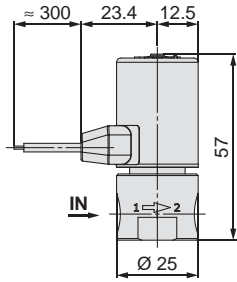
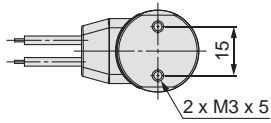

### GS: Grommet with PCB

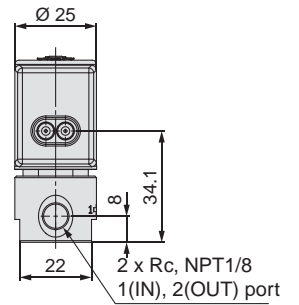
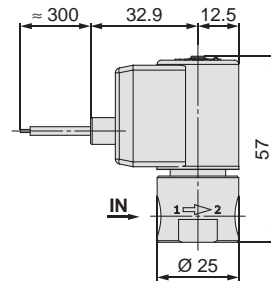
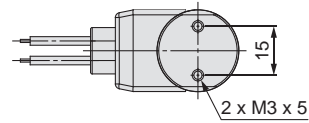

### DS: DIN terminal DZ: DIN terminal with light

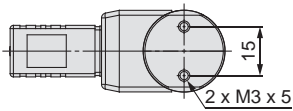

Applicable cable  
Ø 3.5 to Ø 7

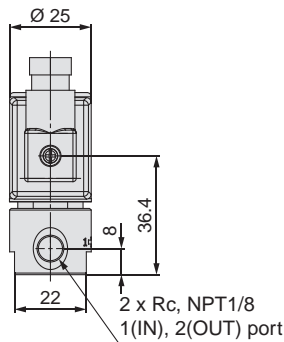
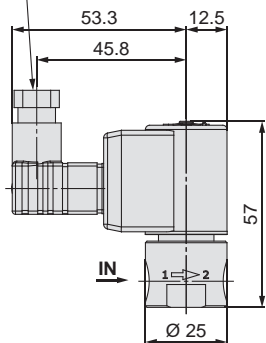

### DN: Without DIN connector

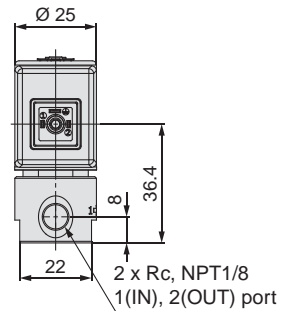
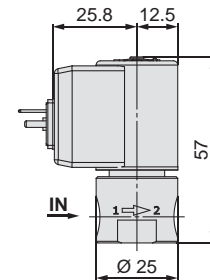
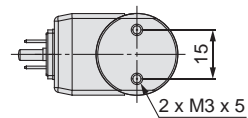

### G thread type

\* Dimensions other than those below are the same as those of the Rc type.

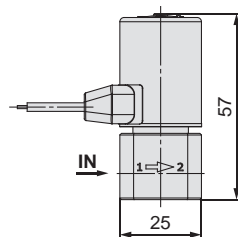
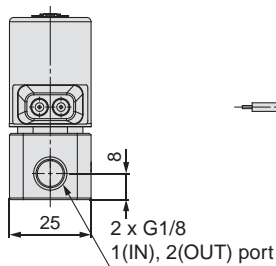
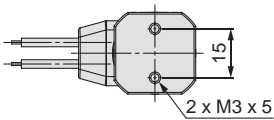



Dimensions: **20** Series, Port Size 1/8 Type

**G: Grommet**

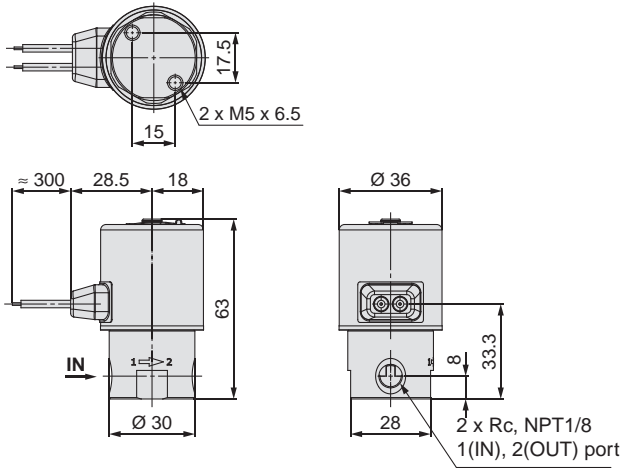

**GS: Grommet with PCB**

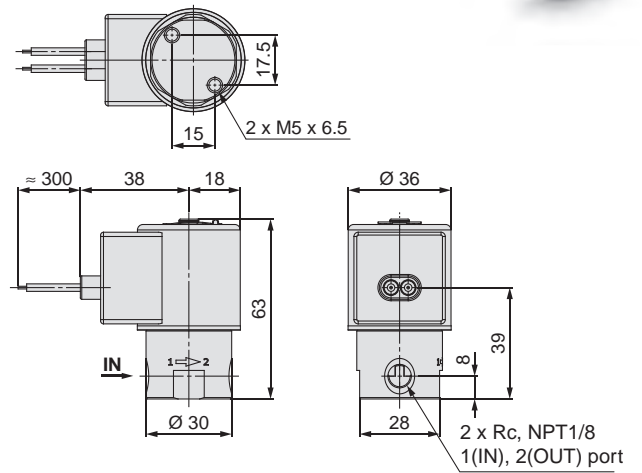

**CS: Conduit**

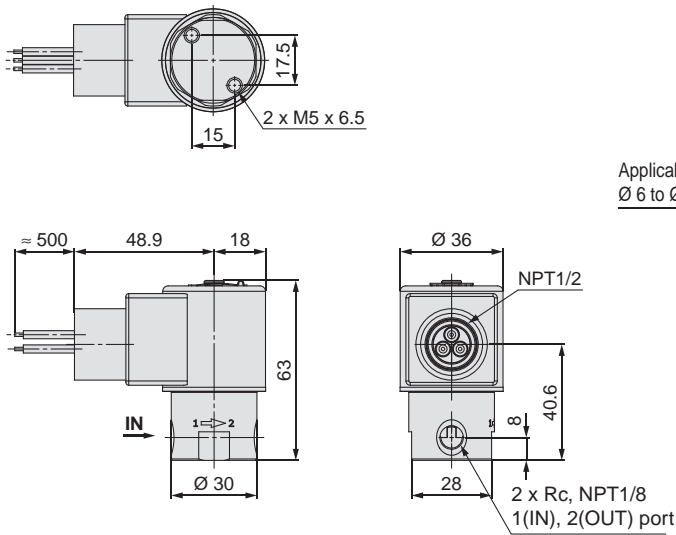

**DS: DIN terminal**  
**DZ: DIN terminal with light**

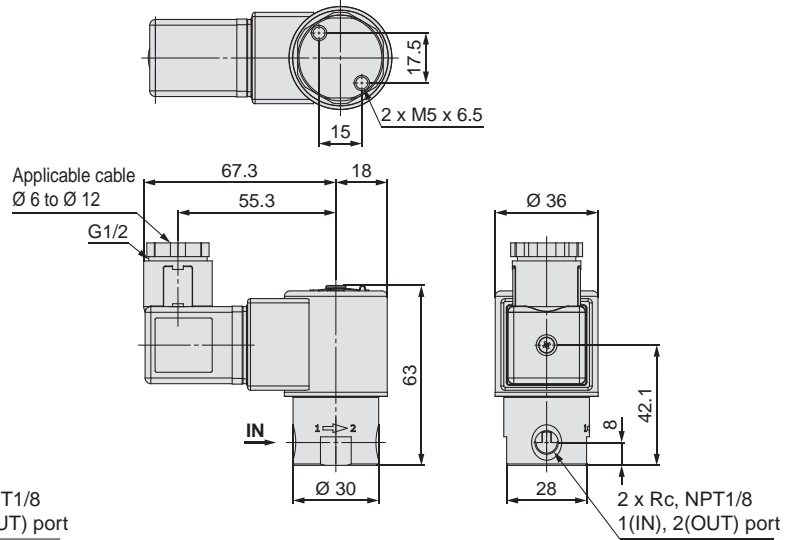

**G thread type**

\* Dimensions other than those below are the same as those of the Rc type.

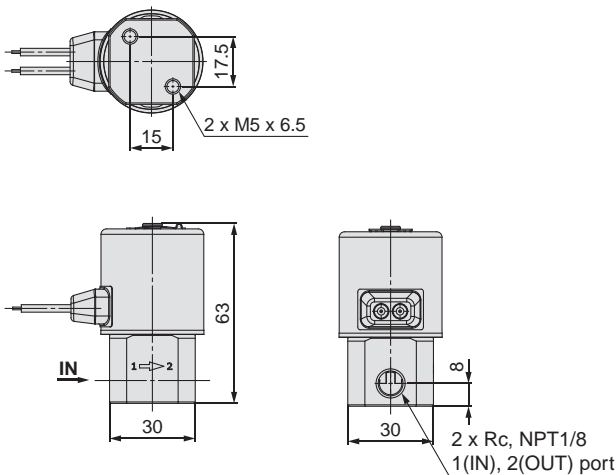

**DN: Without DIN connector**

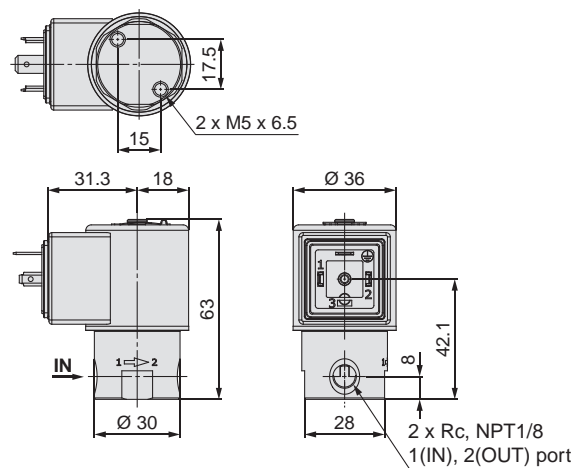

# JSX Series

## Dimensions: **20/30** Series, Port Size 1/4, 3/8 Type



### G: Grommet

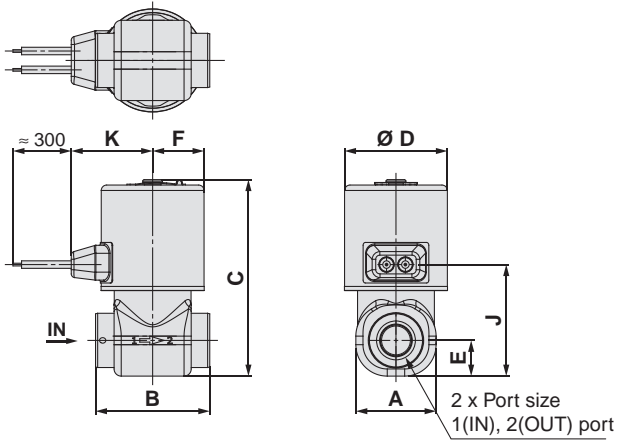

### GS: Grommet with PCB

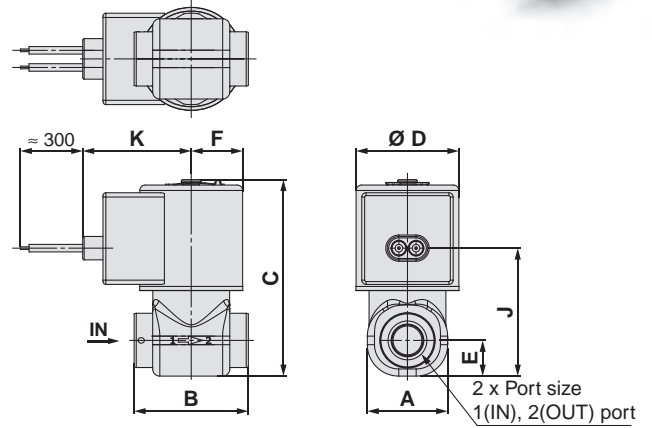

### CS: Conduit

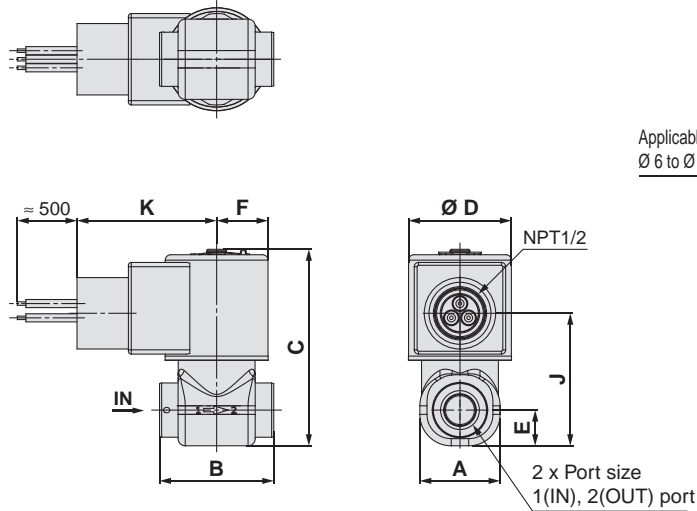

### DS: DIN terminal

### DZ: DIN terminal with light

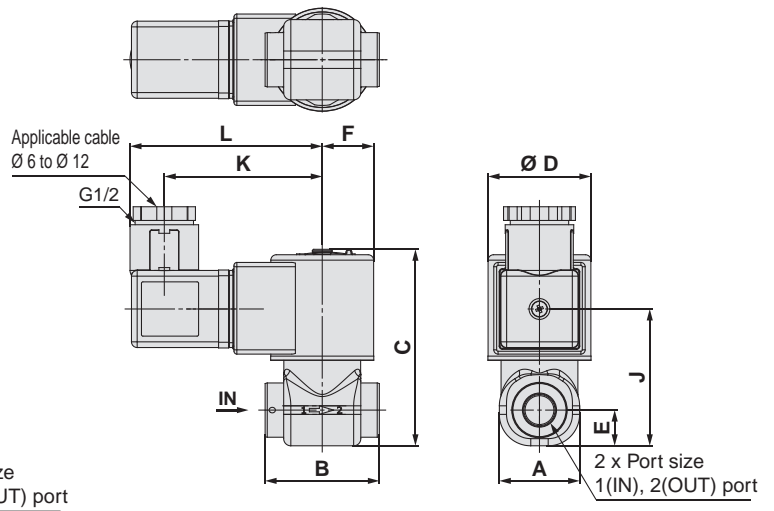

### DN: Without DIN connector

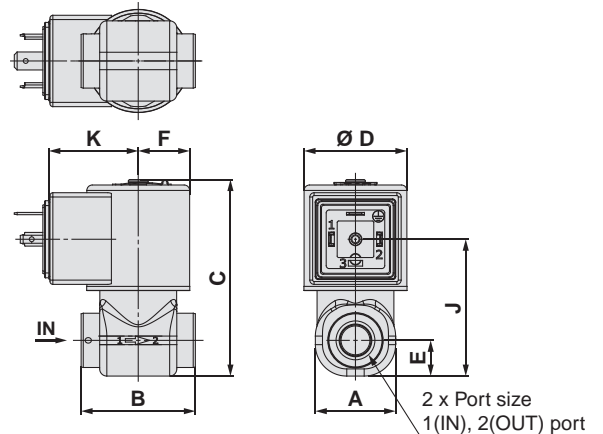

### Dimensions

[mm]

Series	Port size	A	B	C	D	E	F	Grommet		Grommet with PCB		Conduit		DIN terminal			Without DIN connector		
								J	K	J	K	J	K	J	K	L	J	K	
20	1/4	28.1	40	69	36	12.5	18	39	28.5	44.8	38	46.4	48.9	47.9	55.3	67.3	47.9	31.3	
	3/8		48																50.9
	G3/8		48																72
30	1/4	28.1	40	78	42	12.5	21	40	31.1	45.8	41	47.4	51.9	48.9	58.3	70.3	48.9	34.3	
	3/8		48																51.9
	G3/8		48																81

**Dimensions: Bracket Options**

**Port size 1/8 type**

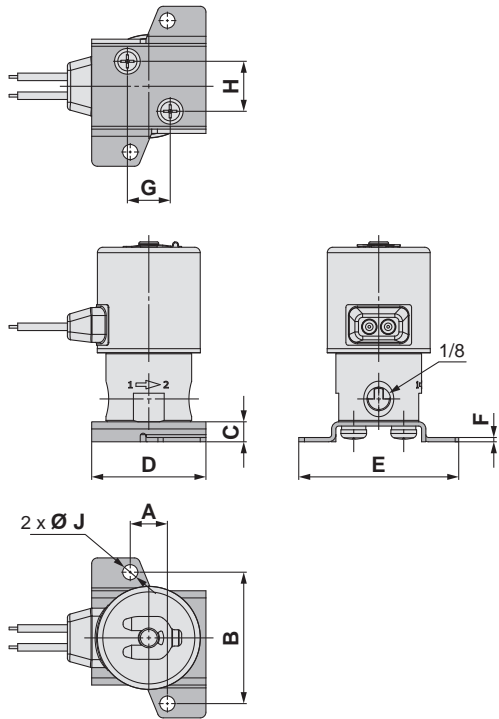

**Port size 1/4, 3/8 type**

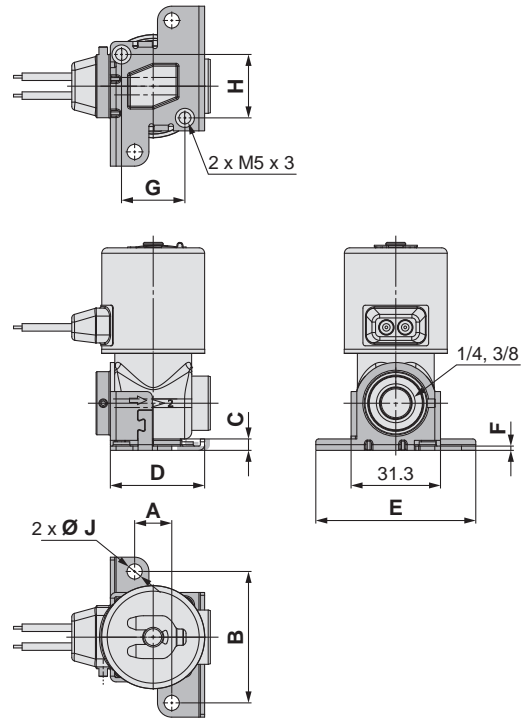

**Dimensions**

[mm]

Series	Port size	A	B	C	D	E	F	G	H	Ø J
<b>10</b>	1/8	14	33	5	20	39	1	—	15	3.4
<b>20</b>	1/8	13	46	7	40	56	1.5	15	17.5	5.3
<b>20/30</b>	1/4, 3/8	13	46	4	33	56	1.5	22.2	22.2	5.3
	G3/8							19	20.6	

# JSX11/21/31 Series

## Table of UL-compliant Products

\* Refer to the table below for UL-compliant products.

**cUL<sup>®</sup> US Recognised**

**G** Grommet 

**GS** Grommet with PCB 

**DN** Without DIN connector 

JSX11	Size/Valve type	Body material	Seal material	Orifice diameter/Port size	Thread type	Rated voltage	Electrical entry	Option
	JSX11		S		N		R	
			F	101	N	1	GS	
			E	201	F	2	DN	
						3		
						4		
						5		
						6		
						7		
						8		
						B		
						J		

JSX21	Size/Valve type	Body material	Seal material	Orifice diameter/Port size	Thread type	Rated voltage	Electrical entry	Option
	JSX21		S		N		R	
			F	301	N	1	GS	
			E	302	F	2	DN	
				303		3		
				402		4		
				403		5		
				502		6		
				503		7		
				702		8		
				703		B		
						J		

JSX31	Size/Valve type	Body material	Seal material	Orifice diameter/Port size	Thread type	Rated voltage	Electrical entry	Option
	JSX31		S		N		R	
			F	402	N	1	GS	
			E	403	F	2	DN	
				502		3		
				503		4		
				702		5		
				703		6		
						7		
						8		
						B		
						J		

\*1 Only applicable to rated voltage symbols "5" and "6"

**cUL<sup>®</sup> US LISTED Listed**

**CS** Conduit 

JSX21	Size/Valve type	Body material	Seal material	Orifice diameter/Port size	Thread type	Rated voltage	Electrical entry	Option
	JSX21		S		N		R	
			F	301	N	1	CS	
			E	302	F	2		
				303		3		
				402		4		
				403		5		
				502		6		
				503		7		
				702		8		
				703		B		
						J		

JSX31	Size/Valve type	Body material	Seal material	Orifice diameter/Port size	Thread type	Rated voltage	Electrical entry	Option
	JSX31		S		N		R	
			F	402	N	1	CS	
			E	403	F	2		
				502		3		
				503		4		
				702		5		
				703		6		
						7		
						8		
						B		
						J		

## Pressure Terminology

### 1. Maximum operating pressure differential

The maximum pressure differential (the difference between the inlet and outlet pressure) which is allowed for operation. When the outlet pressure is 0 MPa, this becomes the maximum operating pressure.

### 2. Maximum system pressure

The maximum pressure that can be applied inside the pipelines (line pressure).

[The pressure differential of the solenoid valve portion must not exceed the maximum operating pressure differential.]

### 3. Withstand pressure

The pressure in which the valve must be withstood without a drop in performance after holding for one minute under prescribed pressure and returning to the operating pressure range. (value under the prescribed conditions)

## Electrical Terminology

### 1. Apparent power (VA)

Volt-ampere is the product of voltage (V) and current (A).

Power consumption (W): For AC,  $W = V \cdot A \cdot \cos \theta$ .

For DC,  $W = V \cdot A$ .

\*  $\cos \theta$  shows power factor.  $\cos \theta \approx 0.9$

### 2. Surge voltage

A high voltage which is momentarily generated by shutting off the power in the shut-off area.

### 3. Degrees of protection

A degree defined in the "JIS C 0920: Waterproof test of electric machinery/appliance and the degree of protection against the intrusion of solid foreign objects."

IP -  -

First digit •      • Second digit

#### ● First Digit:

##### Degree of protection against solid foreign objects

0	Not protected
1	Protected against solid foreign objects of 50 mm Ø and larger
2	Protected against solid foreign objects of 12 mm Ø and larger
3	Protected against solid foreign objects of 2.5 mm Ø and larger
4	Protected against solid foreign objects of 1.0 mm Ø and larger
5	Dust protected
6	Dust-tight

#### ● Second Digit:

##### Degree of protection against water

0	Not protected	—
1	Protected against vertically falling water droplets	Dripproof type 1
2	Protected against vertically falling water droplets when enclosure is tilted up to 15°	Dripproof type 2
3	Protected against rainfall when enclosure is tilted up to 60°	Rainproof type
4	Protected against splashing water	Splashproof type
5	Protected against water jets	Water-jet-proof type
6	Protected against powerful water jets	Powerful water-jet-proof type
7	Protected against the effects of temporary immersion in water	Immersible type
8	Protected against the effects of continuous immersion in water	Submersible type

## Others

### 1. Material

NBR: Nitrile rubber

FKM: Fluororubber

EPDM: Ethylene propylene rubber

### 2. Symbol

In the symbol ()<sub>W</sub>, when the valve is closed, flow is blocked from port 1 to port 2. However, if the pressure in port 2 is higher than port 1, the valve will not be able to block the fluid and it will flow from port 2 to port 1.

# Solenoid Valve Flow Rate Characteristics (How to indicate flow rate characteristics)

Scan the QR code to access software for easy flow rate calculation.

For details ▶



## 1. Indication of flow rate characteristics

The flow rate characteristics of equipment, such as a solenoid valve, etc., are indicated in their specifications as shown in Table (1).

Table (1) Indication of Flow Rate Characteristics

Corresponding equipment	Indication by international standard	Other indications	Compliant standards
Pneumatic equipment	<b>C, b</b>	—	ISO 6358:1989 JIS B 8390:2000
	—	<b>S</b>	JIS B 8390:2000 Equipment: JIS B 8379, 8381-1, 8381-2
		<b>Cv</b>	ANSI/(NFPA)T3.21.3 R1-2008
Process fluid control equipment	<b>Kv</b>	—	IEC 60534-1:2005 IEC 60534-2-3:1997 JIS B 2005-1:2012
	—	<b>Cv</b>	JIS B 2005-2-3:2004 Equipment: JIS B 8471, 8472, 8473

## 2. Pneumatic equipment

### 2.1 Indication according to the international standards

#### (1) Compliant standards

**ISO 6358:1989 : Pneumatic fluid power—Components using compressible fluids—Determination of flow rate characteristics**

**JIS B 8390:2000 : Pneumatic fluid power—Components using compressible fluids—How to test flow rate characteristics**

#### (2) Definition of flow rate characteristics

The flow rate characteristics are indicated as a result of a comparison between the sonic conductance **C** and the critical pressure ratio **b**.

**Sonic conductance C** : Value which divides the passing mass flow rate of a piece of equipment in a choked flow condition by the product of the upstream absolute pressure and the density in a standard condition.

**Critical pressure ratio b** : Pressure ratio (downstream pressure/upstream pressure) which will turn to a choked flow when the value is smaller than this ratio.

**Choked flow** : Flow in which the upstream pressure is higher than the downstream pressure and where sonic speed in a certain part of a piece of equipment is reached.

Gaseous mass flow rate is in proportion to the upstream pressure and not dependent on the downstream pressure.

**Subsonic flow** : Flow greater than the critical pressure ratio.

**Standard condition** : Air in a temperature state of 20 °C, absolute pressure 0.1 MPa (= 100 kPa = 1 bar), relative humidity 65 %.

It is stipulated by adding the “(ANR)” after the unit depicting air volume.

(Standard reference atmosphere)

Compliant standards: ISO 8778:1990 Pneumatic fluid power—Standard reference atmosphere, JIS B 8393:2000: Pneumatic fluid power—Standard reference atmosphere

#### (3) Formula for flow rate

It is described by the practical units as following.

When

$$\frac{P_2 + 0.1}{P_1 + 0.1} \leq b, \text{ choked flow}$$

$$Q = 600 \times C (P_1 + 0.1) \sqrt{\frac{293}{273 + T}} \dots\dots\dots(1)$$

When

$$\frac{P_2 + 0.1}{P_1 + 0.1} > b, \text{ subsonic flow}$$

$$Q = 600 \times C (P_1 + 0.1) \sqrt{1 - \left[ \frac{P_2 + 0.1}{P_1 + 0.1} - b \right]^2} \sqrt{\frac{293}{273 + T}} \dots\dots\dots(2)$$

**Q** : Air flow rate [L/min (ANR)]

**C** : Sonic conductance [ $\text{dm}^3/(\text{s}\cdot\text{bar})$ ],  $\text{dm}^3$  (Cubic decimeter) of SI units = L (litre)

**b** : Critical pressure ratio [—]

**P<sub>1</sub>** : Upstream pressure [MPa]

**P<sub>2</sub>** : Downstream pressure [MPa]

**T** : Temperature [°C]

\* Formula of subsonic flow is the elliptic analogous curve.

Flow rate characteristics are shown in Graph (1). For details, please use the calculation software available from the SMC website.

Example)

Obtain the air flow rate for **P<sub>1</sub>** = 0.4 [MPa], **P<sub>2</sub>** = 0.3 [MPa], **T** = 20 [°C] when a solenoid valve is performed in **C** = 2 [ $\text{dm}^3/(\text{s}\cdot\text{bar})$ ] and **b** = 0.3.

According to formula 1, the maximum flow rate =  $600 \times 2 \times (0.4 + 0.1) \times \sqrt{\frac{293}{273 + 20}} = 600$  [L/min (ANR)]

$$\text{Pressure ratio} = \frac{0.3 + 0.1}{0.4 + 0.1} = 0.8$$

Based on Graph (1), it will be 0.7 if the pressure ratio is 0.8 and the flow rate ratio is **b** = 0.3.  
Hence, the flow rate = Max. flow x flow ratio =  $600 \times 0.7 = 420$  [L/min (ANR)]

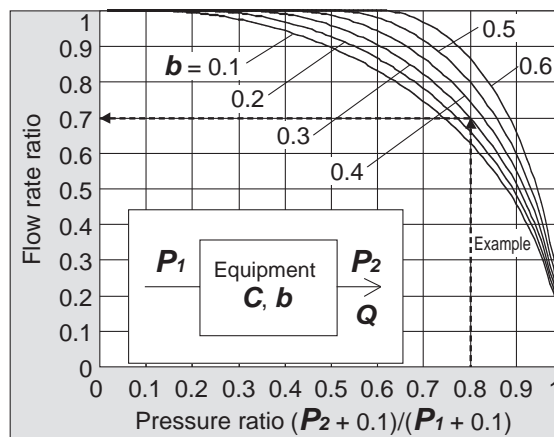

**Graph (1) Flow rate characteristics**

#### (4) Test method

Connect the piece of test equipment to the test circuit as shown in Fig. (1). While maintaining the upstream pressure at a fixed value above 0.3 MPa, measure the maximum flow to be saturated initially. Next, measure this flow rate at 80 %, 60 %, 40 %, and 20 %, as well as the upstream and downstream pressure. The sonic conductance **C** can be calculated based on this maximum flow rate. Use the data of the others and the subsonic flow formula to find **b**, and calculate the critical pressure ratio **b** from that average.

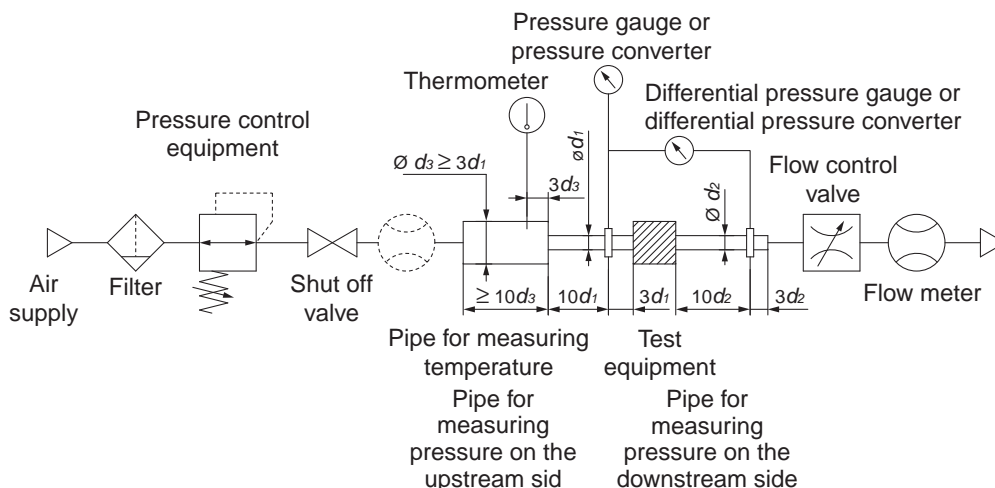

**Fig. (1) Test circuit based on ISO 6358:1989, JIS B 8390:2000**

## 2.2 Effective area **S**

(1) Compliant standards

**JIS B 8390:2000: Pneumatic fluid power—Components using compressible fluids—  
How to test flow rate characteristics**

Equipment standards: **JIS B 8373: Solenoid valve for pneumatics**

**JIS B 8379: Silencer for pneumatics**

**JIS B 8381-1: Fittings for pneumatics—Part 1: Push-in fittings for thermoplastic resin tubing**

**JIS B 8381-2: Fittings for pneumatics—Part 2: Compression fittings for thermoplastic resin tubing**

(2) Definition of flow rate characteristics

Effective area **S**: Cross-sectional area that has an ideal throttle without friction or reduced flow. The value is derived by calculating pressure changes inside of an air tank when the compressed air is discharged from a piece of equipment mounted on the tank in a choked flow. The value of the effective area **S**, like that of sonic conductance **C**, expresses the “ease of flow.”

(3) Formula for flow rate

When

$\frac{P_2 + 0.1}{P_1 + 0.1} \leq 0.5$ , **choked flow**

$$Q = 120 \times S (P_1 + 0.1) \sqrt{\frac{293}{273 + T}} \dots\dots\dots(3)$$

When

$\frac{P_2 + 0.1}{P_1 + 0.1} > 0.5$ , **subsonic flow**

$$Q = 240 \times S \sqrt{(P_2 + 0.1) (P_1 - P_2)} \sqrt{\frac{293}{273 + T}} \dots\dots\dots(4)$$

Conversion with sonic conductance **C**:

$$S = 5.0 \times C \dots\dots\dots(5)$$

**Q** : Air flow rate [L/min (ANR)]

**S** : Effective area [mm<sup>2</sup>]

**P<sub>1</sub>** : Upstream pressure [MPa]

**P<sub>2</sub>** : Downstream pressure [MPa]

**T** : Temperature [°C]

\* The formula for subsonic flow (4) is only applicable when the critical pressure ratio **b** is the unknown piece of equipment. In the sonic conductance **C** formula (2), it is the same formula as when **b** = 0.5.

(4) Test method

Connect the piece of test equipment to the test circuit as shown in Fig. (2). Discharge the air from the air tank filled with compressed air at a fixed value above 0.6 MPa (0.5 MPa) into the atmosphere until the pressure inside the tank falls to 0.25 MPa (0.2 MPa). Measure the discharge time and the residual pressure inside the tank after discharging until it has returned to the normal value. Then, calculate the effective area **S** using the following formula. Select an air tank with a volume within the specified range of the test equipment’s effective area. For JIS B 8379, the pressure values are in parentheses and the coefficient of the formula is 12.9.

$$S = 12.1 \frac{V}{t} \log_{10} \left( \frac{P_s + 0.1}{P + 0.1} \right) \sqrt{\frac{293}{T}} \dots\dots\dots(6)$$

**S** : Effective area [mm<sup>2</sup>]

**V** : Air tank capacity [L]

**t** : Discharging time [s]

**P<sub>s</sub>** : Pressure inside air tank before discharging [MPa]

**P** : Residual pressure inside air tank after discharging [MPa]

**T** : Temperature inside air tank before discharging [K]

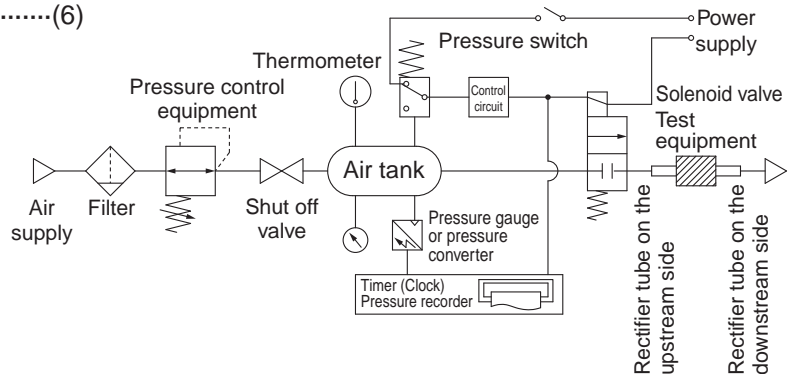

**Fig. (2) Test circuit based on JIS B 8390:2000**

**2.3 Flow coefficient Cv factor**

The United States Standard ANSI/(NFPA)T3.21.3:R1-2008R: Pneumatic fluid power—Flow rating test procedure and reporting method for fixed orifice components

This standard defines the **Cv** factor of the flow coefficient by the following formula that is based on the test conducted by the test circuit analogous to ISO 6358.

$$Cv = \frac{Q}{114.5 \sqrt{\frac{\Delta P (P_2 + Pa)}{T_1}}} \dots\dots\dots (7)$$

$\Delta P$  : Pressure drop between the static pressure tapping ports [bar]

$P_1$  : Pressure of the upstream tapping port [bar gauge]

$P_2$  : Pressure of the downstream tapping port [bar gauge]:  $P_2 = P_1 - \Delta P$

$Q$  : Flow rate [L/s standard condition]

$Pa$  : Atmospheric pressure [bar absolute]

$T_1$  : Upstream absolute temperature [K]

The test conditions are  $P_1 + Pa = 6.5 \pm 0.2$  bar absolute,  $T_1 = 297 \pm 5K$ ,  $0.07 \text{ bar} \leq \Delta P \leq 0.14 \text{ bar}$ .

This is the same concept as the effective area **A** which ISO 6358 stipulates as being applicable only when the pressure drop is smaller than the upstream pressure and the compression of air does not become a problem.

**3. Process fluid control equipment**

(1) Compliant standards

**IEC 60534-1:2005: Industrial-process control valves. Part 1: Control valve terminology and general considerations**

**IEC 60534-2-3:1997: Industrial-process control valves. Part 2: Flow capacity, Section Three-Test procedures**

**JIS B 2005-1:2012: Industrial-process control valves – Part 1: Control valve terminology and general considerations**

**JIS B 2005-2-3:2004: Industrial-process control valves – Part 2: Flow capacity – Section 3: Test procedures**

**Equipment standards: JIS B 8471: Solenoid valve for water**

**JIS B 8472: Solenoid valve for steam**

**JIS B 8473: Solenoid valve for fuel oil**

(2) Definition of flow rate characteristics

**Kv** factor: Value of the clean water flow rate (represented by m<sup>3</sup>/h) which runs through a valve (test equipment) at 5 to 40 °C when the pressure difference is 1 x 10<sup>5</sup> Pa (1 bar). It is calculated using the following formula.

$$Kv = Q \sqrt{\frac{1 \times 10^5}{\Delta P} \cdot \frac{\rho}{1000}} \dots\dots\dots (8)$$

**Kv**: Flow coefficient [m<sup>3</sup>/h]

**Q** : Flow rate [m<sup>3</sup>/h]

$\Delta P$ : Pressure difference [Pa]

$\rho$  : Density of fluid [kg/m<sup>3</sup>]

(3) Formula of flow rate

It is described by practical units. Also, the flow rate characteristics are shown in Graph (2).

In the case of liquids:

$$Q = 53 Kv \sqrt{\frac{\Delta P}{G}} \dots\dots\dots (9)$$

**Q** : Flow rate [L/min]

**Kv**: Flow coefficient [m<sup>3</sup>/h]

$\Delta P$ : Pressure difference [MPa]

**G** : Relative density [water = 1]

In the case of saturated aqueous vapour:

$$Q = 232 Kv \sqrt{\Delta P (P_2 + 0.1)} \dots\dots\dots (10)$$

**Q** : Flow rate [kg/h]

**Kv**: Flow coefficient [m<sup>3</sup>/h]

$\Delta P$ : Pressure difference [MPa]

$P_1$  : Upstream pressure [MPa]:  $\Delta P = P_1 - P_2$

$P_2$  : Downstream pressure [MPa]

Conversion of flow coefficient:

$$Kv = 0.865 Cv \dots\dots\dots(11)$$

Here,

**Cv** factor: Value of the clean water flow rate (represented by US gal/min) which runs through a valve at 40 to 100°F when the pressure difference is 1 lbf/in<sup>2</sup> (psi)

The values of **Kv** and **Cv** factors for pneumatic purposes are different due to different test methods.

(4) Test method

Connect the piece of test equipment to the test circuit as shown in Fig. (3), and run water at 5 to 40 °C. Then, measure the flow rate with a pressure difference where vapourization does not occur in a turbulent flow (pressure difference of 0.035 MPa to 0.075 MPa when the inlet pressure is within 0.15 MPa to 0.6 MPa). However, as the turbulent flow is definitely caused, the pressure difference needs to be set with a large enough difference so that the Reynolds number does not fall below  $1 \times 10^5$ , and the inlet pressure needs to be set slightly higher to prevent vapourization of the liquid. Substitute the measurement results in formula (8) to calculate **Kv**.

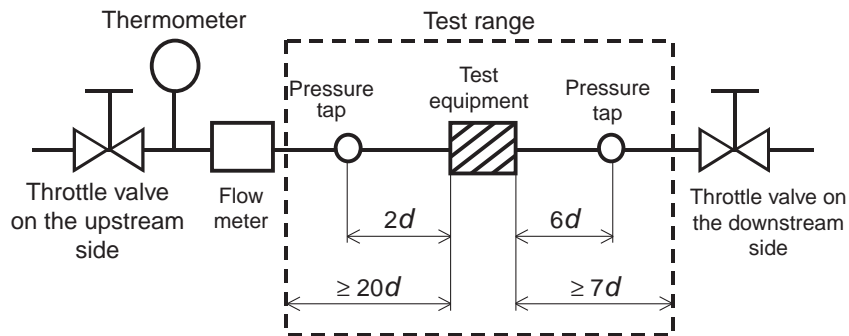
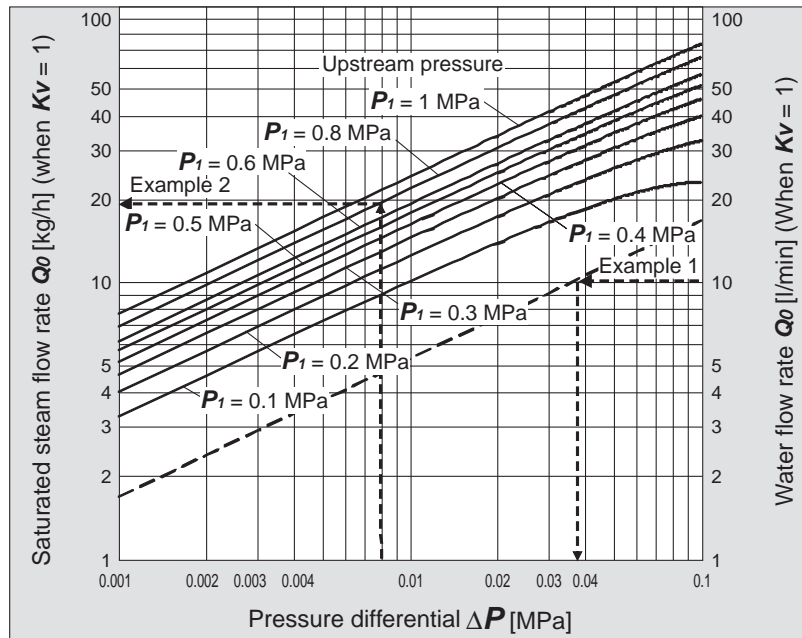

Fig. (3) Test circuit based on IEC 60534-2-3, JIS B 2005-2-3



Graph (2) Flow rate characteristics

Example 1)

Obtain the pressure difference when 15 [L/min] of water runs through a solenoid valve with a **Kv** = 1.5 [m<sup>3</sup>/h]. As the flow rate when **Kv** = 1 is calculated as the formula:  $Q_0 = 15 \times 1/1.5 = 10$  [L/min], read off  $\Delta P$  when  $Q_0$  is 10 [L/min] in Graph (2). The reading is 0.036 [MPa].

Example 2)

Obtain the saturated steam flow rate when  $P_1 = 0.8$  [MPa] and  $\Delta P = 0.008$  [MPa] with a solenoid valve with a **Kv** = 0.05 [m<sup>3</sup>/h]. Read off  $Q_0$  when  $P_1$  is 0.8 and  $\Delta P$  is 0.008 in Graph (2), the reading is 20 [kg/h]. Therefore, the flow rate is calculated as the formula:  $Q = 0.05/1 \times 20 = 1$  [kg/h].



# JSX Series Specific Product Precautions 1

Be sure to read this before handling the products. Refer to the back cover for safety instructions. For 2-port solenoid valve for fluid control precautions, refer to the “Handling Precautions for SMC Products” and the “Operation Manual” on the SMC website: <https://www.smc.eu>

## Design

### ⚠ Warning

#### 1. Confirm the specifications.

Give careful consideration to the operating conditions, such as the application, fluid, and environment, and use within the specified operating ranges. If the product is used beyond the specification range, this may cause the product to break or malfunction. We do not guarantee against any damage if the product is used outside of the specification range.

#### 2. Cannot be used as an emergency shutoff valve, etc.

This product is not designed for safety applications such as an emergency shutoff valve. If the valves are used in this type of system, other reliable safety assurance measures should also be adopted.

#### 3. Cannot be used for pressure (including vacuum) holding

It is not usable for an application such as holding the pressure (including vacuum) inside of a pressure vessel because air leakage is entailed in valves.

#### 4. Closed liquid circuit

In a closed circuit, when liquid is static, pressure could rise due to changes in temperature. This pressure rise could cause malfunction and damage to components such as valves. To prevent this, install a relief valve in the system.

#### 5. Actuator drive

When an actuator, such as a cylinder, is to be driven using a valve, take appropriate measures to prevent potential danger caused by actuator operation.

#### 6. When energizing continuously for long periods of time

If a valve is energized continuously for long periods of time, the rise in temperature due to heat-up of the coil assembly may cause a decline in solenoid valve performance, reduce service life, or have adverse effects on peripheral equipment. Avoid using in a tightly shut container. Install the valve in a well-ventilated area. As valves are heated by energization, do not touch them with bare hands during or immediately after energization.

#### 7. Water hammer

When an impact, such as water hammer, etc., caused by rapid pressure fluctuation is applied, the valve may be damaged. Install water hammer relief equipment (accumulator, etc.) or use an SMC water hammer relief valve (VXR series). Please contact SMC for details.

#### 8. Reverse pressure

If there is a possibility that reverse pressure will be applied, take countermeasures by installing a check valve, etc., on the downstream side.

#### 9. Do not disassemble the product and replacement parts or make any modifications, including additional machining.

Doing so may cause human injury and/or an accident.

## Operating Environment

### ⚠ Warning

Do not use the product in such locations as those described below.

#### 1. Locations with atmospheres where water vapour is present or locations where corrosive fluids (chemicals), sea water, or water may come into contact with the product

Implement appropriate protective measures if water will be applied to the product for long periods of time, even for products which have IP65 or IP67 enclosures. Such water may enter through microscopic gaps in the product's external surfaces, resulting in fire damage or short-circuiting of the solenoid valve coils. If installing the product in close proximity to equipment, such as machine tools, processing machines, etc., which uses large amounts of liquids or oils, be sure to confirm that liquid dispersal or spatter from the peripheral equipment does not come into contact with the product.

#### 2. Locations with explosive atmospheres

#### 3. Locations subject to vibration or impact

#### 4. Locations where radiated heat will be received from nearby heat sources

## Operating Environment

### ⚠ Warning

#### 5. Locations that are outdoors (Excludes outdoor specification valves)

Although using an indoor specification product outdoors voids its product warranty, if outdoor use proves unavoidable, be sure to implement the protective measures mentioned below.

1) Install a protective cover, etc., to protect the product from direct sunlight.

2) Encase the product in an enclosure to protect it from rain and wind.

\* If only a roof-type cover is provided for the product, it will not be sufficiently protected from side winds or rain splashing up from the ground, which will result in water adhering to and entering the product. In addition, when the product is encased in an enclosure, be sure to implement proper ventilation measures to prevent overheating due to long-term energizing of the product.

3) Be sure to confirm that the location is not one in which condensation is easily generated.

\* If the product is used in an environment with large temperature changes, etc., condensation may be generated and water may adhere to the external surface of the product. Be sure to implement protective measures against condensation, such as ambient temperature control, in such locations where condensation is easily generated.

#### 6. Locations where freezing may occur within piping lines

##### [When the fluid is liquid]

If the product is to be used in cold regions or in winter, be sure to implement measures to prevent the freezing of fluids.

If the fluid is likely to freeze, implement measures such as draining the water in the piping when the equipment is OFF, or installing a heater or insulation in the piping.

If warming the solenoid valve, be sure to avoid the coil portion as it will result in poor heat dissipation.

##### [When the fluid is air]

With large flow rates, drain may be generated due to adiabatic expansion, resulting in freezing.

Be sure to periodically drain the product or conduct drain removal using an air dryer.

## Fluid

### ⚠ Warning

#### 1. Fluid selection

1) Compatibility between the components and fluids should be checked in the application before use.

2) Since the compatibility of the fluid used may vary depending on its type, additives, concentration, temperature, etc., give sufficient consideration when selecting the material. Please contact SMC if anything is unclear.

3) Use a fluid with a dynamic viscosity of 50 mm<sup>2</sup>/s or less.

#### 2. Do not use the product with the fluids shown below.

1) Fluids that are harmful to humans

2) Combustion-supporting or flammable fluids

3) Corrosive gas

4) Sea water, Saline solution

#### 3. Take measures to prevent static electricity, since some fluids can cause static electricity.

#### 4. Fluid temperature

Operate within the specified operating fluid temperature range.

#### 5. Install a filter (strainer) to ensure clean fluids.

1) The use of a fluid that contains foreign matter can cause problems, such as malfunction and seal failure by promoting the wear of the valve seat and armature, by sticking to the sliding parts of the armature, etc. Install a filter (strainer) on the upstream side of the valve to remove foreign matter.  
Air: 5 μm or less Water: 100 mesh or more

2) Replace or clean the filter (strainer) when the pressure drop reaches 0.1 MPa to prevent them from getting clogged.



# JSX Series Specific Product Precautions 2

Be sure to read this before handling the products. Refer to the back cover for safety instructions. For 2-port solenoid valve for fluid control precautions, refer to the “Handling Precautions for SMC Products” and the “Operation Manual” on the SMC website: <https://www.smc.eu>

## Fluid Quality

### ⚠ Warning

#### 1. Air

- 1) Do not use compressed air that contains chemicals, synthetic oils that include organic solvents, salt, corrosive gases, etc., as it can cause malfunction or damage.
- 2) Compressed air that contains excessive drainage may cause the malfunction of valves and other pneumatic equipment. Install an aftercooler or an air dryer on the inlet side of the valve as a countermeasure against drainage.
- 3) If excessive carbon powder is generated by the compressor, it may adhere to the inside of the valves and cause malfunction. Install a mist separator on the inlet side of the valve as a countermeasure to remove any carbon powder.
- 4) For compressed air quality, refer to the Best Pneumatics No. 6 catalog.
- 5) When operating fluid air with a dew point of  $-70\text{ }^{\circ}\text{C}$  or lower, the inside of the valve may wear and the product life will be shortened.

#### 2. Water

- 1) Operation failure due to the rust generated or chloride in the piping may result in the breakage of the product. If the product is broken, fluids or components may be ejected, so install a protective measure.
- 2) In the case that water contains substances such as calcium and magnesium, which generate hard scale and sludge, install water softening equipment and a filter (strainer) directly upstream from the valve to remove these substances, as this scale and sludge can cause the valve to malfunction.
- 3) The water pressure of tap water is usually 0.4 MPa or less, but the pressure can sometimes increase to 1.0 MPa in tall buildings. Therefore, pay attention to the maximum operating pressure differential.

#### 3. Oil

Generally, FKM is used as seal material, as it is resistant to oil. The resistance of the seal material may deteriorate depending on the type of oil, manufacturer, or additives. Check the resistance before use.

## Mounting

### ⚠ Warning

1. Ensure sufficient space for maintenance and inspection.
2. When mounting the product, avoid sources of vibration, or adjust the arm from the body to the minimum length so that resonance will not occur.
3. Do not install the product near a heat source and install it in locations where the product is not affected by radiant heat.
4. Do not apply external force to the coil section.

When the product is installed, apply a wrench to the outside of the piping connection while paying attention that it will not come into contact with the coil.

5. Do not warm the coil section with a heat insulator, etc. When insulation is used as a countermeasure against freezing, the insulation should be limited to the piping and body only. Do not insulate the coil. This can cause the coil to burn out.

6. If air leakage increases or equipment does not operate properly, stop operation.

After installation or during maintenance, check that the product is correctly mounted with appropriate functional and leakage inspections by supplying compressed air and power supplies. Do not use the product when the equipment does not operate correctly.

7. Do not touch the valve while it is being energized or right after it has been energized.

Valves will reach high temperatures after operation. Use caution, as there is a danger of being burnt if a valve is touched directly.

## Mounting

### ⚠ Caution

#### 1. Mounting orientation

When mounting a valve with its coil positioned downward, foreign objects in the fluid will adhere to the iron core, leading to a malfunction. Mount a valve with its coil position upward.

#### 2. Painting and coating

Warnings or specifications printed or labelled on the product should not be erased, removed, or covered up.

## How to Assemble Brackets

### ⚠ Caution

#### 1. Port size 1/8 type

##### How to assemble

- 1) Mount the bracket ① to the bottom of the valve using mounting screws ②.

##### Tightening torque

- 10 series:  $0.6\text{ N}\cdot\text{m} \pm 5\%$   
20 series:  $1.5\text{ N}\cdot\text{m} \pm 5\%$

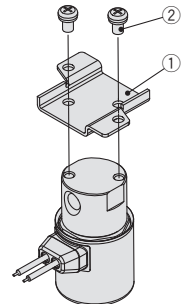

#### Bracket Assembly Part Nos.

Series	Port size	Thread type	Bracket assembly part no. (With mounting screws)	Material
10	1/8	Rc, NPT, G	JSX021-12A-3	Stainless steel
20			JSX022-12A-3	

#### 2. Port size 1/4, 3/8 type

##### How to assemble

- 1) Insert bracket ① to the IN port side of the valve.
  - 2) Secure it with the hexagon socket set screw ②.
- Tightening torque:  $0.4\text{ N}\cdot\text{m} \pm 5\%$

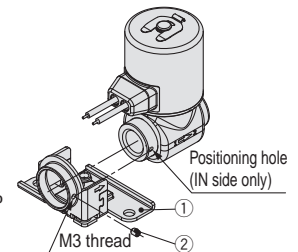

#### Caution on Assembly

- 1) Pay attention to the bracket inserting direction. The positioning hole is on the IN port side only. The bracket cannot be mounted to the OUT port side.
- 2) The bracket should be mounted after connecting the fitting. (Refer to the “Piping” in the Specific Product Precautions.)

\* The bracket is shipped together with the product.

#### Bracket Assembly Part Nos.

Series	Port size	Thread type	Bracket assembly part no. (With set screw)	Material
20/30	1/4	Rc, NPT, G	JSX022-12A-2-1	Stainless steel
		Rc, NPT	JSX022-12A-2-1	
	G	JSX022-12A-2-2		

## Piping

### ⚠ Warning

1. There may be cases in which the tubing detaches from the fitting and thrashes around uncontrollably due to tubing degradation or fitting breakage. To prevent this, fit the tubing with a protective cover or secure it in place.
2. If using tube piping, secure the product to a permanent fixture. Do not suspend it by the tubing.



# JSX Series Specific Product Precautions 3

Be sure to read this before handling the products. Refer to the back cover for safety instructions. For 2-port solenoid valve for fluid control precautions, refer to the "Handling Precautions for SMC Products" and the "Operation Manual" on the SMC website: <https://www.smc.eu>

## Piping

### ⚠ Caution

1. For handling One-touch fittings, refer to the "Fittings and Tubing Precautions" in the Handling Precautions for SMC Products.

#### 2. Preparation before piping

Before piping is connected, it should be thoroughly blown out with air (flushing) or washed to remove chips, cutting oil, and other debris from inside the pipe. Install piping so that it does not apply pulling, pressing, bending, or other forces on the valve body.

#### 3. Winding of sealant tape

When connecting pipes, fittings, etc., be sure that chips from the pipe threads and sealing material do not enter the valve. Furthermore, when sealant tape is used, leave 1.5 to 2 thread ridges exposed at the end of the threads.

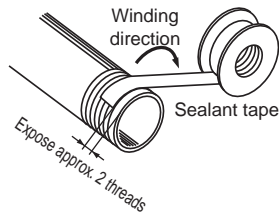

#### 4. Connection of piping and fittings

When screwing SMC fittings into the valve, tighten them as follows.

Tighten the fitting by hand, then use a suitable wrench to tighten the hexagonal portion of the body an additional two or three turns. For the tightening torque, refer to the table below.

Connection thread size	Proper tightening torque [N·m]
1/8	3 to 5
1/4	8 to 12
3/8	15 to 20

#### 5. When using a fitting other than an SMC fitting

Follow the instructions given by the fitting manufacturer.

#### 6. Avoid connecting ground lines to piping, as this may cause the electric corrosion of the system.

#### 7. When connecting piping to a product, avoid mistakes regarding the supply port, etc.

#### 8. Recommended piping conditions

When connecting piping to the One-touch fitting, use a pipe length with sufficient margin, in accordance with the piping conditions shown in Fig. 1. Also, when using a tying band, etc., to bind the piping together, make sure that external force does not come to bear on the fitting. (See Fig. 2.)

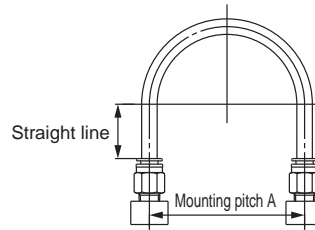

Fig. 1 Recommended piping

Unit: mm

Tubing size	Mounting pitch A			Straight line length
	Nylon tubing	Soft nylon tubing	Polyurethane tubing	
Ø 1/8"	44 or more	29 or more	25 or more	16 or more
Ø 6	84 or more	39 or more	39 or more	30 or more
Ø 1/4"	89 or more	56 or more	57 or more	32 or more
Ø 8	112 or more	58 or more	52 or more	40 or more
Ø 10	140 or more	70 or more	69 or more	50 or more
Ø 12	168 or more	82 or more	88 or more	60 or more

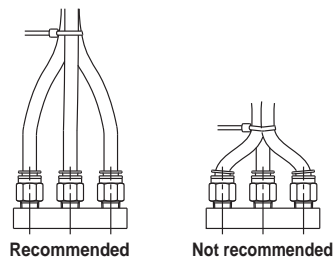
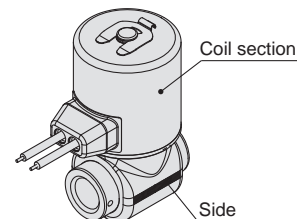

Fig. 2 When using a tying band to bind the piping together

#### 9. When connecting a fitting to the valve, clamp the side of the body with a vise.



#### 10. When using a bracket with 1/4" or 3/8" bore size, connect the fitting in accordance with the following procedure.

- Step 1) Connect the fittings to both the IN and OUT sides of the valve.
- Step 2) Insert the IN side port of the valve into the bracket hole.
- Step 3) Secure the valve to the bracket with the hexagon socket set screw.



If the tightening torque is applied to the fitting while the valve is secured to the bracket, the bracket might be broken.



# JSX Series Specific Product Precautions 4

Be sure to read this before handling the products. Refer to the back cover for safety instructions. For 2-port solenoid valve for fluid control precautions, refer to the “Handling Precautions for SMC Products” and the “Operation Manual” on the SMC website: <https://www.smc.eu>

## Wiring

### Warning

The solenoid valve is an electrical product. For safety, install an appropriate fuse and circuit breaker before use. When using multiple solenoid valves, it is not sufficient to merely install one fuse. For protecting the equipment more safely, select an appropriate fuse to each circuit of the solenoid valve.

### Caution

1. As a rule, use electrical wire with a cross sectional area of 0.5 to 1.25 mm<sup>2</sup> for wiring.

2. External force applied to the lead wire

If an excessive force is applied to the lead wire, this may cause faulty wiring. Take appropriate measures so that a force of 10 N or more is not applied to the lead wire. Do not bend the lead wires beyond 90° with a radius of less than 20 mm or damage may occur.

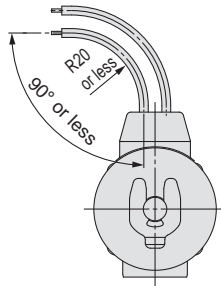

3. Use electrical circuits which do not generate chattering in their contacts.

4. Use voltage which is within ± 10 % of the rated voltage. In cases with a DC power supply where importance is placed on responsiveness, stay within ± 5 % of the rated value. The voltage drop is the value in the lead wire section connecting the coil.

5. When a surge from the solenoid affects the electrical circuitry, install a surge voltage suppressor, etc., in parallel with the solenoid. Or, use the product with a surge voltage suppressor.

6. Leakage voltage

When the solenoid valve is operated using the controller, etc., the leakage voltage should be the product allowable leakage voltage or less. Particularly when using a resistor in parallel with a switching element and using a C-R element to protect the switching element, take note that leakage current will flow through the resistor, C-R element, etc., creating a possible danger that the valve may not turn off.

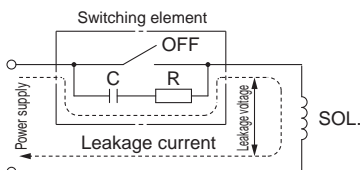

AC coil: 5% or less of rated voltage  
DC coil: 2% or less of rated voltage

## Electrical Connections

### Caution

1. Grommet

Lead wire: AWG20 Insulator O.D.: 2.6 mm

Rated voltage	Lead wire colour	
	①	②
DC	Black	Red
100 VAC	Blue	Blue
200 VAC	Red	Red
Other AC	Grey	Grey

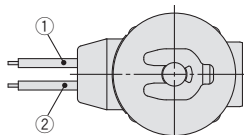

\* There is no polarity.

## Electrical Connections

### Caution

2. Conduit

Lead wire: AWG18 Insulator O.D.: 2.8 mm

Rated voltage	Lead wire colour		
	①	②	③
DC	Black	Red	Green/Yellow
100 VAC	Blue	Blue	Green/Yellow
200 VAC	Red	Red	Green/Yellow
Other AC	Grey	Grey	Green/Yellow

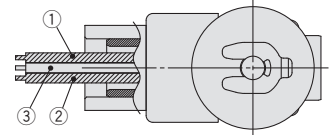

\* There is no polarity.

\* ③: Ground wire

3. DIN terminal

#### Disassembly

- After loosening the binding head screw with flange, then if the housing is pulled in the direction of the arrow, the connector will be removed from the solenoid valve.
- Pull out the binding head screw with flange from the housing.
- There is a cutout on the bottom of the terminal block. Insert a small flat head screwdriver, etc., into this cutout, and remove the terminal block from the housing. (Refer to the figure below.)
- Remove the gland nut, and pull out the washer and the rubber seal.

#### Wiring

- Pass the cable through the gland nut, washer, and rubber seal in this order, and insert these parts into the housing.
- Loosen the binding head screw of the terminal block, then insert the core wire or the crimped terminal of the lead wire into the terminal, and securely fix it with the binding head screw. The binding head screw of the terminal block is M3.
  - \*1 Tighten the screw to a torque of between 0.5 and 0.6 N·m.
  - \*2 Cable O.D.: Ø 6 to Ø 12 mm
  - \*3 For an outside cable diameter of Ø 9 to Ø 12 mm, remove the internal parts of the rubber seal before use.

#### Assembly

- Pass the cable through the gland nut, washer, rubber seal, and the housing in this order, and connect to the terminal block. Then, set the terminal block inside the housing. (Push in the terminal block until it snaps into position.)
- Insert the rubber seal and the washer in this order into the cable entry of the housing, and then tighten the gland nut securely.
- Insert the gasket between the bottom part of the terminal block and the plug attached to the equipment, and then insert the binding head screw with flange from the top of the housing, and tighten it.
  - \*1 Tighten the screw to a torque of between 0.5 and 0.6 N·m.
  - \*2 The orientation of the connector can be changed in steps of 90° by changing the method of assembling the housing and the terminal block.

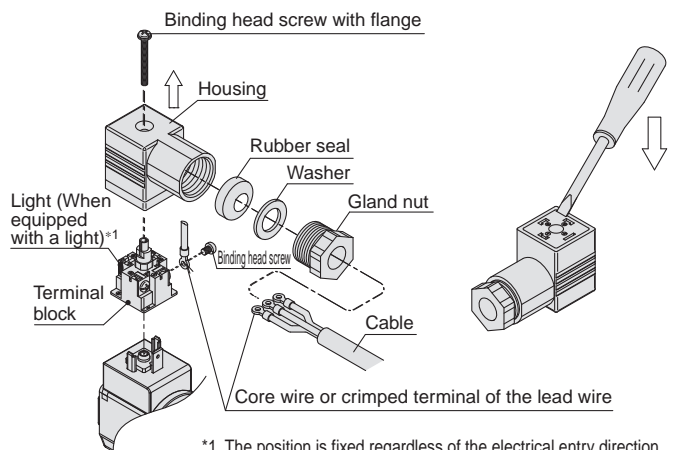

\*1 The position is fixed regardless of the electrical entry direction.



# JSX Series Specific Product Precautions 5

Be sure to read this before handling the products. Refer to the back cover for safety instructions. For 2-port solenoid valve for fluid control precautions, refer to the "Handling Precautions for SMC Products" and the "Operation Manual" on the SMC website: <https://www.smc.eu>

## Electrical Connections

### ⚠ Caution

Internal connections are as shown below. Make connections to the power supply accordingly.

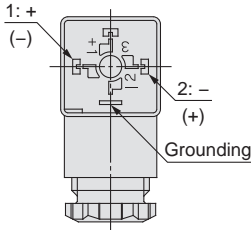

Terminal no.	1	2
DIN terminal	+ (-)	- (+)

\* There is no polarity.

## DIN (EN175301-803) Terminal

This DIN terminal corresponds to the Form C DIN connector with an 8 mm terminal pitch.

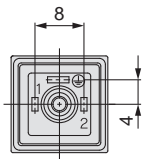

10 series

This DIN terminal corresponds to the Form A DIN connector with an 18 mm terminal pitch.

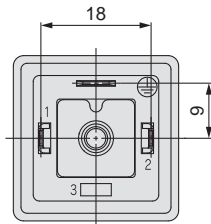

20/30 series

## Electrical Circuits

### ⚠ Caution

#### 1. DC circuit

##### ●Grommet

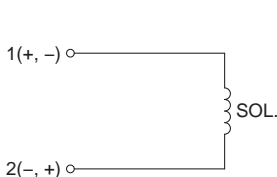

Without electrical option

##### ●Grommet, Conduit, DIN terminal

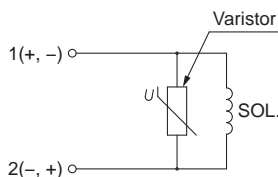

With surge voltage suppressor

##### ●DIN terminal

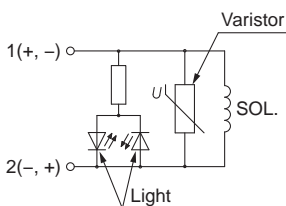

With light/surge voltage suppressor

## Electrical Circuits

### ⚠ Caution

#### 2. AC circuit

The standard product is equipped with surge voltage suppressor.

##### ●Grommet, Conduit, DIN terminal

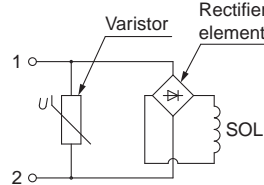

Without electrical option

##### ●DIN terminal

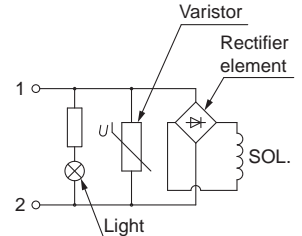

With light/surge voltage suppressor

## Maintenance

### ⚠ Warning

#### 1. Removal of product

- 1) Shut off the fluid supply and release the fluid pressure in the system.
- 2) Shut off the power supply.
- 3) Confirm that the valve temperature has dropped sufficiently before removing the product.

#### 2. Replace or clean filters (strainers) periodically.

- 1) Replace filters after one year of use, or earlier if the pressure drop reaches 0.1 MPa.
- 2) Clean strainers when the pressure drop reaches 0.1 MPa.

#### 3. Exhaust the drainage from air filters periodically.

If condensation in the drain bowl is not emptied on a regular basis, the bowl will overflow and allow the condensation to enter the compressed air lines. This causes the malfunction of pneumatic equipment. If the drain bowl is difficult to check and remove, the installation of a drain bowl with an auto drain option is recommended.

#### 4. Low frequency operation

Switch valves at least once every 30 days to prevent malfunction. Also, in order to use them under the optimum state, conduct a regular inspection biannually.

#### 5. Storage

In the case of long-term storage after use, thoroughly remove all moisture and store it in a location where the product is not exposed to sunlight and higher humidity to prevent rust and deterioration of rubber materials, etc.

#### 6. Perform a maintenance and inspection periodically.

Confirm that the product is mounted correctly by conducting suitable function and leakage tests periodically. If air leakage increases or equipment does not operate properly, stop operation.

## Return of Product

### ⚠ Warning

If the product to be returned is contaminated or is possibly contaminated with substances that are harmful to humans, for safety reasons, please contact SMC beforehand and then employ a specialist cleaning company to decontaminate the product. After the decontamination prescribed above has been carried out, submit a Product Return Request Sheet or the Detoxification/Decontamination Certificate to SMC and await SMC's approval and further instructions before attempting to return the item. Please refer to the International Chemical Safety Cards (ICSC) for a list of harmful substances.

If you have any further questions, please don't hesitate to contact your SMC sales representative.

## Safety Instructions

These safety instructions are intended to prevent hazardous situations and/or equipment damage. These instructions indicate the level of potential hazard with the labels of “Caution,” “Warning” or “Danger.” They are all important notes for safety and must be followed in addition to International Standards (ISO/IEC)<sup>1)</sup>, and other safety regulations.

### Caution:

**Caution** indicates a hazard with a low level of risk which, if not avoided, could result in minor or moderate injury.

### Warning:

**Warning** indicates a hazard with a medium level of risk which, if not avoided, could result in death or serious injury.

### Danger:

**Danger** indicates a hazard with a high level of risk which, if not avoided, will result in death or serious injury.

- 1) ISO 4414: Pneumatic fluid power – General rules relating to systems.  
ISO 4413: Hydraulic fluid power – General rules relating to systems.  
IEC 60204-1: Safety of machinery – Electrical equipment of machines.  
(Part 1: General requirements)  
ISO 10218-1: Manipulating industrial robots - Safety.  
etc.

## Warning

### 1. The compatibility of the product is the responsibility of the person who designs the equipment or decides its specifications.

Since the product specified here is used under various operating conditions, its compatibility with specific equipment must be decided by the person who designs the equipment or decides its specifications based on necessary analysis and test results. The expected performance and safety assurance of the equipment will be the responsibility of the person who has determined its compatibility with the product. This person should also continuously review all specifications of the product referring to its latest catalogue information, with a view to giving due consideration to any possibility of equipment failure when configuring the equipment.

### 2. Only personnel with appropriate training should operate machinery and equipment.

The product specified here may become unsafe if handled incorrectly. The assembly, operation and maintenance of machines or equipment including our products must be performed by an operator who is appropriately trained and experienced.

### 3. Do not service or attempt to remove product and machinery/equipment until safety is confirmed.

1. The inspection and maintenance of machinery/equipment should only be performed after measures to prevent falling or runaway of the driven objects have been confirmed.
2. When the product is to be removed, confirm that the safety measures as mentioned above are implemented and the power from any appropriate source is cut, and read and understand the specific product precautions of all relevant products carefully.
3. Before machinery/equipment is restarted, take measures to prevent unexpected operation and malfunction.

### 4. Contact SMC beforehand and take special consideration of safety measures if the product is to be used in any of the following conditions.

1. Conditions and environments outside of the given specifications, or use outdoors or in a place exposed to direct sunlight.
2. Installation on equipment in conjunction with atomic energy, railways, air navigation, space, shipping, vehicles, military, medical treatment, combustion and recreation, or equipment in contact with food and beverages, emergency stop circuits, clutch and brake circuits in press applications, safety equipment or other applications unsuitable for the standard specifications described in the product catalogue.
3. An application which could have negative effects on people, property, or animals requiring special safety analysis.
4. Use in an interlock circuit, which requires the provision of double interlock for possible failure by using a mechanical protective function, and periodical checks to confirm proper operation.

## Caution

### 1. The product is provided for use in manufacturing industries.

The product herein described is basically provided for peaceful use in manufacturing industries.  
If considering using the product in other industries, consult SMC beforehand and exchange specifications or a contract if necessary.  
If anything is unclear, contact your nearest sales branch.

## Limited warranty and Disclaimer/Compliance Requirements

The product used is subject to the following “Limited warranty and Disclaimer” and “Compliance Requirements”. Read and accept them before using the product.

### Limited warranty and Disclaimer

1. The warranty period of the product is 1 year in service or 1.5 years after the product is delivered, whichever is first.<sup>2)</sup> Also, the product may have specified durability, running distance or replacement parts. Please consult your nearest sales branch.
  2. For any failure or damage reported within the warranty period which is clearly our responsibility, a replacement product or necessary parts will be provided. This limited warranty applies only to our product independently, and not to any other damage incurred due to the failure of the product.
  3. Prior to using SMC products, please read and understand the warranty terms and disclaimers noted in the specified catalogue for the particular products.
- 2) Vacuum pads are excluded from this 1 year warranty.  
A vacuum pad is a consumable part, so it is warranted for a year after it is delivered. Also, even within the warranty period, the wear of a product due to the use of the vacuum pad or failure due to the deterioration of rubber material are not covered by the limited warranty.

### Compliance Requirements

1. The use of SMC products with production equipment for the manufacture of weapons of mass destruction (WMD) or any other weapon is strictly prohibited.
2. The exports of SMC products or technology from one country to another are governed by the relevant security laws and regulations of the countries involved in the transaction. Prior to the shipment of a SMC product to another country, assure that all local rules governing that export are known and followed.

## Caution

### SMC products are not intended for use as instruments for legal metrology.

Measurement instruments that SMC manufactures or sells have not been qualified by type approval tests relevant to the metrology (measurement) laws of each country.  
Therefore, SMC products cannot be used for business or certification ordained by the metrology (measurement) laws of each country.

## Safety Instructions

Be sure to read “Handling Precautions for SMC Products” (M-E03-3) before using.