

Clean Air Filter

Built-in Hollow Fibre Element

- Nominal filtration rating: **0.01** μm (filtration efficiency 99.99%)
- Initial pressure drop: **0.03** MPa (at inlet pressure 0.7 MPa, maximum flow)
- Maximum operating pressure: **1.0** MPa (at 20°C)

SFD100

Up to **100** ℓ/min

SFD200

Up to **500** ℓ/min

SFD101/102 (Made to Order)

Up to **100** ℓ/min



Restriction of Hazardous Substances

RoHS compliant

Series SFD

CAT.EUS120-5A-UK



Two types of piping ports are available: clean one-touch fitting and female-threaded pipe fitting

Clear resin case

- Easy to confirm if an element is dirty.
- Polycarbonated a material is resistant to alcohol-based cleaning solutions.

Replacement element



SFD200

Can be disassembled. (Cartridge type)

Replaceable hollow fibre elements

Made to Order

Stainless steel or aluminum cases are available.

Metal case that is suitable for an atmosphere exposed to organic solvents and chemicals. (Fluids: Air and (Nitrogen))

SFD100	SFD200	SFD101	SFD102
			
		Made to Order	

Type	Disposable type (non-replaceable element)			Cartridge type (replaceable element)				
Flow rate ℓ/min (ANR) (at inlet pressure 0.7 MPa)	Up to 60	Up to 80	Up to 100	Up to 300	Up to 400	Up to 500	Up to 100	
Port size	One-touch fitting	ø4	ø6	ø8	ø8	ø10	ø12	—
	Female thread	—	—	Rc 1/4, G 1/4 NPT 1/4	—	—	Rc 1/4, G 1/4 NPT 1/4	Rc 1/4, G 1/4, NPT 1/4
Case material	Resin			Resin		Aluminum	Stainless steel	
Fluid	Air (Nitrogen)							
Nominal filtration rating	0.01 μm (filtration efficiency: 99.99%) Note)							
Initial pressure drop	0.03 MPa (at inlet pressure 0.7 MPa, maximum flow)							
Maximum operating pressure	1.0 MPa (in case of nitrogen: 0.99 MPa)							
Operating temperature	5 to 45°C							

Note) The clean air filter is designed for the filtration of solid objects. It is not suitable for the separation of water and oil.

Integrated production in a clean environment

Under a clean environment, all components have undergone ultrasonic cleaning. Assembly, inspection and antistatic double packaging processes are conducted in an integrated production system.

Quality Control

At the time of shipment, the SFD series clean air filter is 100% inspected.

Shipping inspection

- Purification test
- Airtight test

Assembly environment

- Clean room : **M5.5 (ISO class 7)***
- Clean bench: **M3.5 (ISO class 5)***

* Fed. Std. 209E () : based on ISO14644-1.

Application Examples

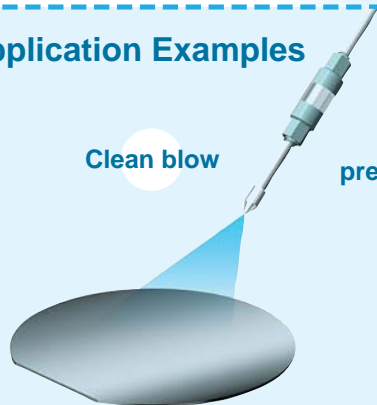

Protection of precision equipment

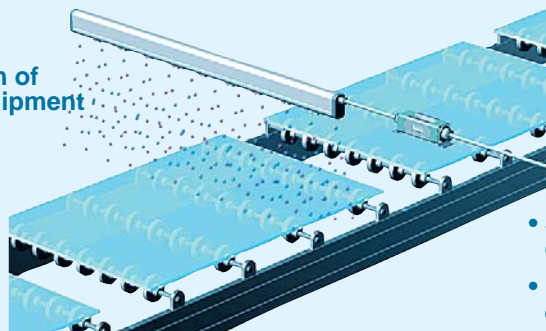

- Substitution of chamber
- Fluid pumping, etc.

* When blowing, take care not to entrain ambient air which could contaminate the workpieces.

Circuit Examples

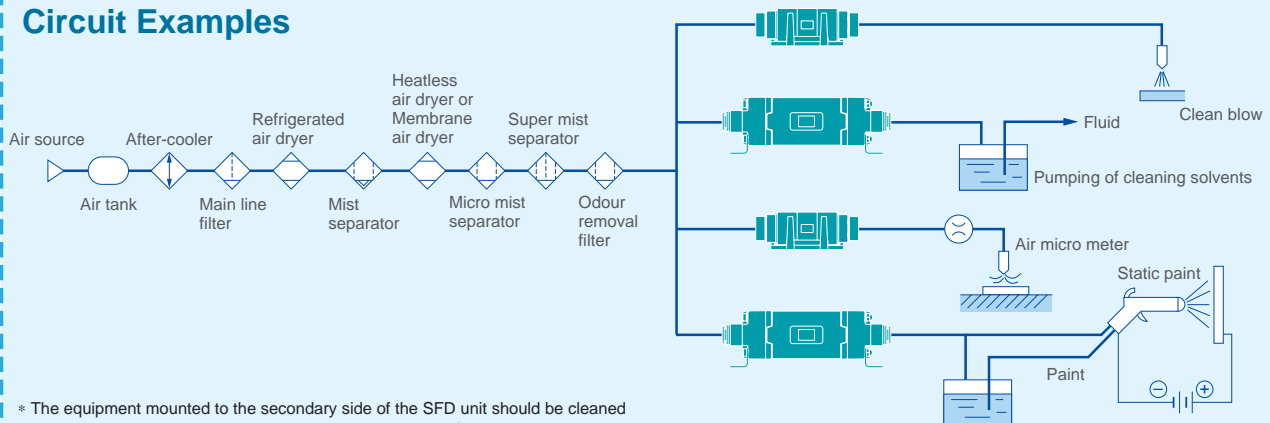

* The equipment mounted to the secondary side of the SFD unit should be cleaned by flushing and have the same level of cleanliness as the SFD unit.

Hollow fibre membrane

The hollow fibre membrane has a porous construction with numerous fine holes on a straw type fibre membrane wall. These fine holes are distributed in layers, and the layers are overlapped between the external face and internal face of the membrane.

The hollow fibre membrane filter traps and filtrates the impurities from the compressed air through the overlapping layered fine holes.

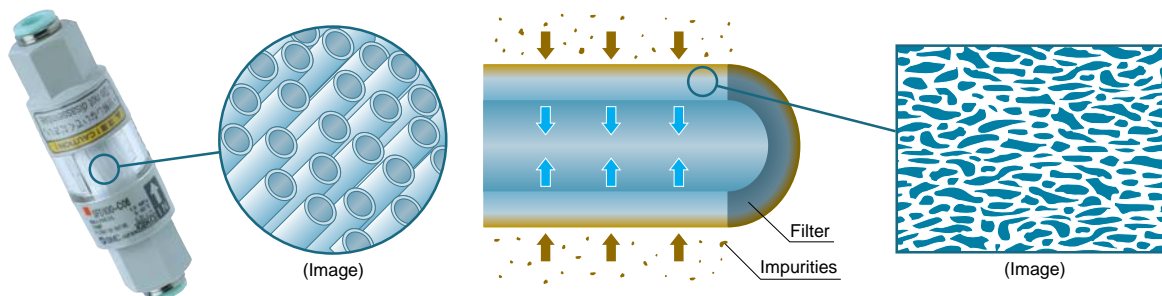

Series SFD Model Selection

Select the model by using the following procedures involving the inlet pressure and the maximum flow rate.

[Example] Inlet pressure: 0.6 MPa

Maximum flow rate: 100 ℓ /min (ANR)

1. Obtain the intersection A for the inlet pressure and the maximum flow rate by using the maximum flow rate chart.
2. If the obtained intersection A is above the maximum flow rate line, the SFD200-C12, -□02, -C10, or -C08 can be selected.

Note) Please be sure to select a model which is above the obtained intersection A. If the obtained intersection A is below the maximum flow rate line, overflow will occur. This will cause nonconformance in which the specification will not be satisfied.

Maximum Flow Rate

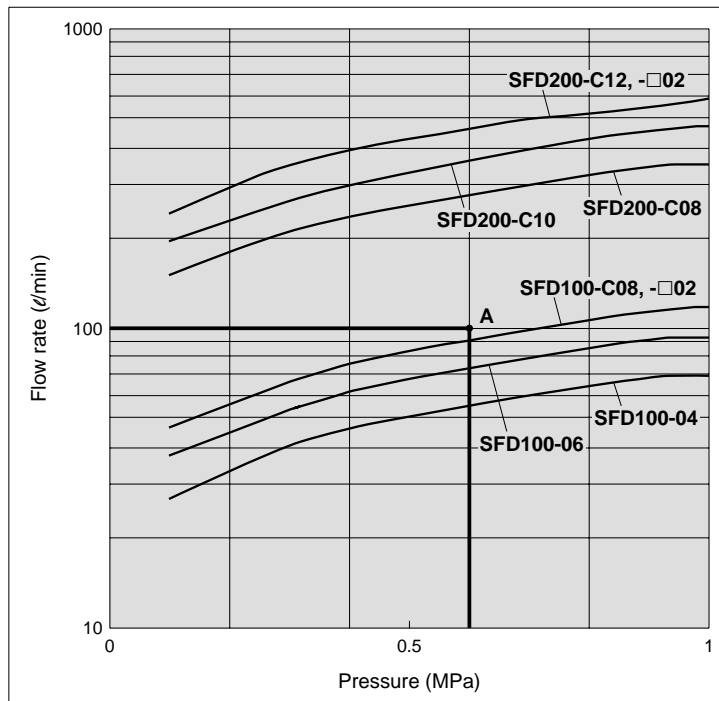

Clean Air Filter

Series SFD

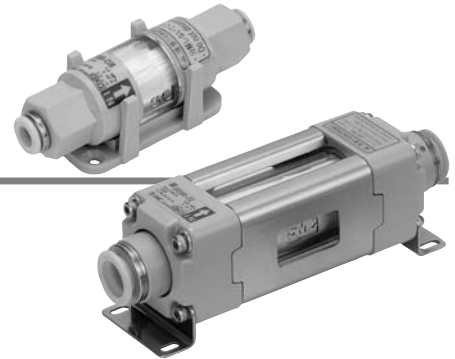

How to Order

SFD 1 0 0 - C08 □

Clean air filter

Size

Symbol	Max. flow rate
1	100 ℓ/min (ANR)
2	500 ℓ/min (ANR)

Case material

Symbol	Material
0	Resin
1	Aluminum
2	Stainless steel

Symbol 1 and 2 are made to order.
For details, refer to page 5.

Option

Symbol	Option
-	None
B	Bracket (SFD100 only)

* The brackets are provided with the SFD200 series as standard. (-)

Port size

Symbol	Connection size	Note
C04	ø4	Clean one-touch fitting (KP series)
C06	ø6	
C08	ø8	
C10	ø10	
C12	ø12	SFD200 only
02	Rc 1/4	Female thread SFD100/200
N02	NPT 1/4	
F02	G 1/4	

Different diameters for IN and OUT ports are made to order.
For details, refer to page 6.

Relationship between Operating Temperature and Max. Operating Pressure

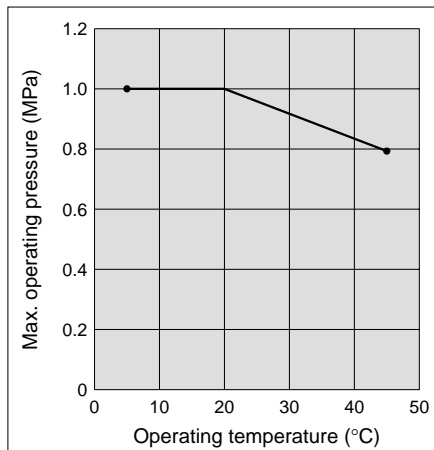

Specifications

Model	SFD10□	SFD20□
Port size	One-touch fitting ø4, ø6, ø8 Rc, NPT, G 1/4	One-touch fitting ø8, ø10, ø12 Rc, NPT, G 1/4
Fluid	Air (Nitrogen)	Air (Nitrogen)
Air flow capacity	Up to 100 ℓ/min (ANR)	Up to 500 ℓ/min (ANR)
Nominal filtration rating ^{Note 1)}	0.01 μm (99.99%)	
Max. operating pressure ^{Note 2)}	1.0 MPa (in case of nitrogen: 0.99 MPa)	
Operating temperature	5 to 45°C	
Initial pressure drop	0.03 MPa (at inlet pressure 0.7 MPa, maximum flow)	
Element differential proof pressure ^{Note 3)}	0.5 MPa	
Proof pressure	1.5 MPa	
Element service life	1 year, or when the pressure drop reaches 0.1 MPa.	

Note 1) Measured under SMC's specified conditions.

Note 2) The maximum operating pressure is at 20°C. For other temperatures, refer to the figure on the left (relationship between the operating temperature and maximum operating pressure).

Note 3) This means that the element does not break at 0.5 MPa. See "Specific Product Precautions".

Model	Port size	Rated flow (ℓ/min (ANR)) ^{Note)}	Weight
SFD100	ø4 (One-touch fitting)	60	35 g
	ø6 (One-touch fitting)	80	35 g
	ø8 (One-touch fitting)	100	35 g
	Rc, NPT, G 1/4	100	35 g
SFD101	Rc, NPT, G 1/4	100	60 g
SFD102	Rc, NPT, G 1/4	100	150 g
SFD200	ø8 (One-touch fitting)	300	190 g
	ø10 (One-touch fitting)	400	190 g
	ø12 (One-touch fitting)	500	190 g
	Rc, NPT, G 1/4	500	260 g

Note) The maximum flow rate when the inlet pressure is 0.7 MPa.

Series SFD

Flow Characteristics

SFD100-C04

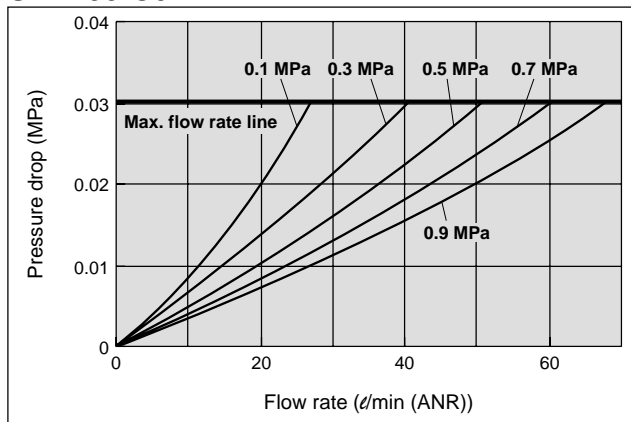

SFD200-C08

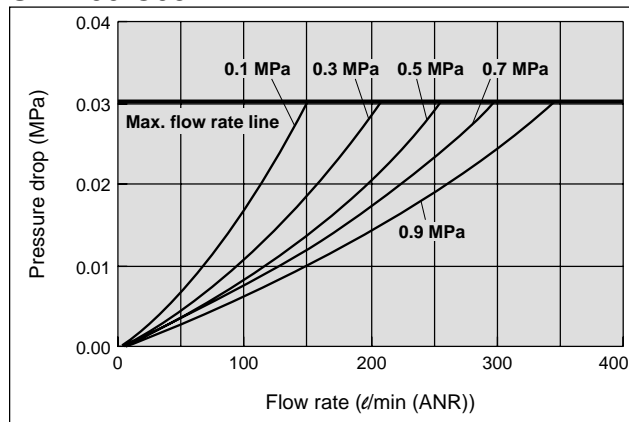

SFD100-C06

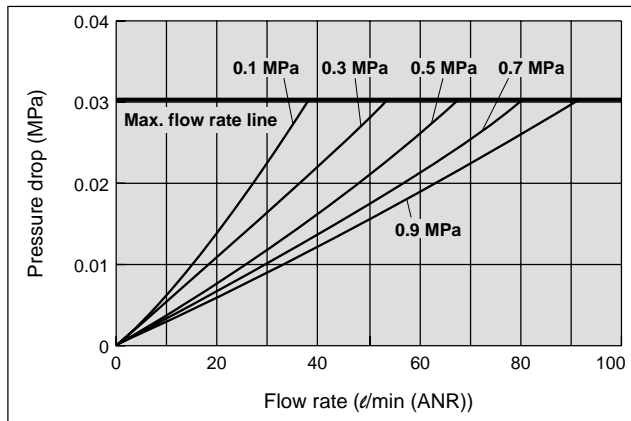

SFD200-C10

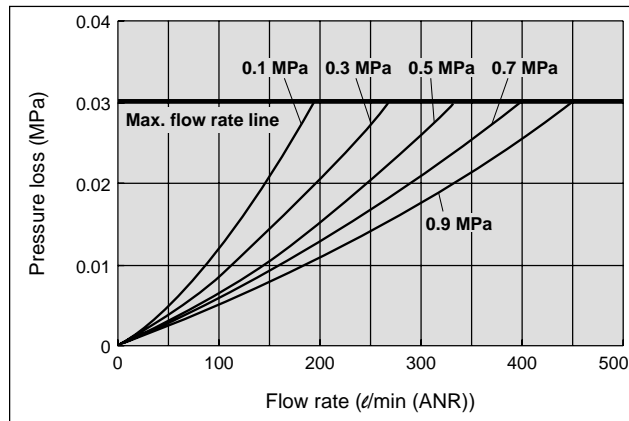

SFD100-C08, -02, -N02, -F02

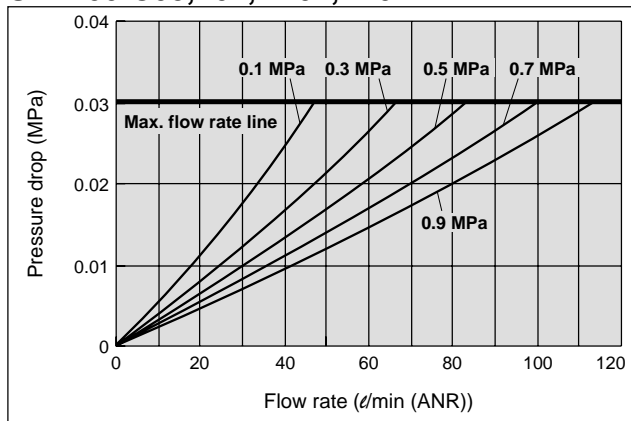

SFD200-C12, -02, -N02, -F02

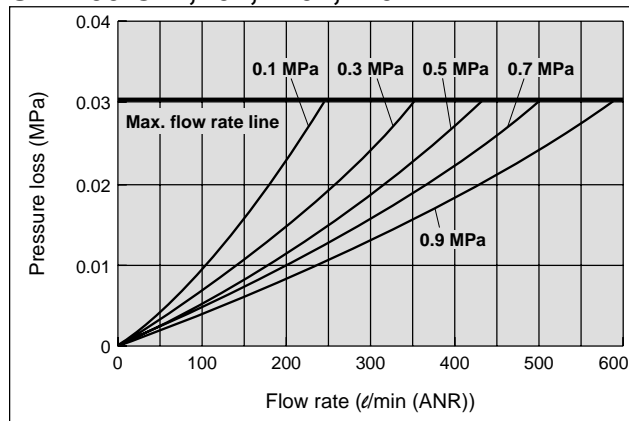

Construction

SFD100-C□

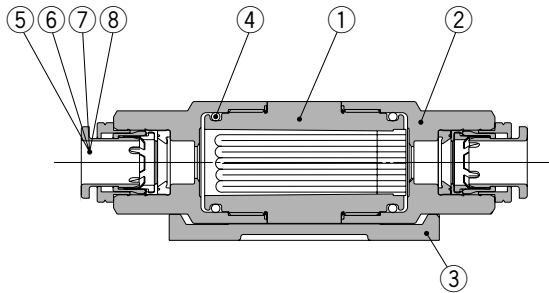

SFD100-□02

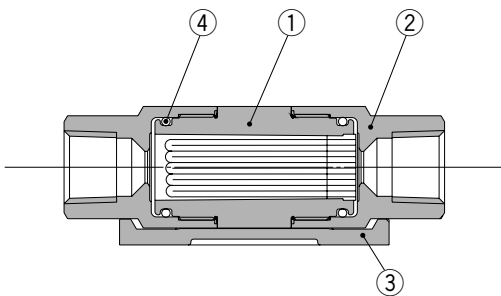

SFD200-C□

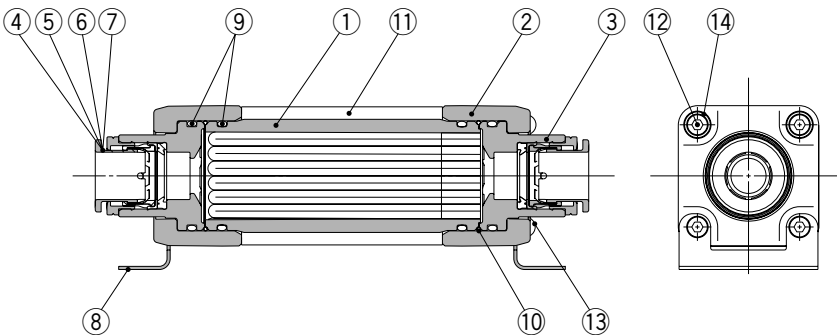

SFD200-□02

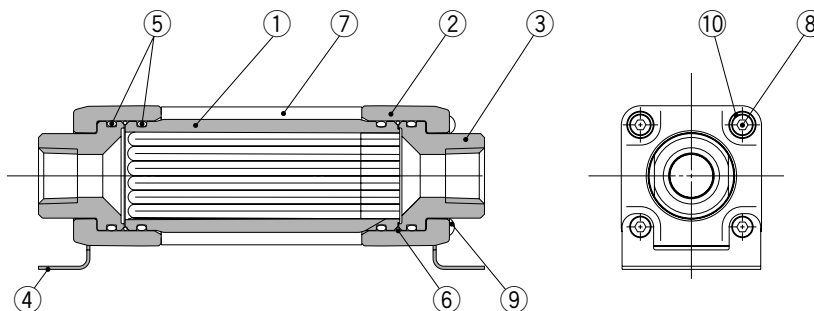

Component Parts

No.	Description	Material	Note
1	Element	Case: Clear resin	
2	Cover	Resin	
3	Bracket	Resin	
4	O-ring	Rubber	
5	Seal	Rubber	
6	Cushion	Rubber	
7	Stopper	Stainless steel alloy	
8	Cassette	Stainless steel alloy	

Replacement Parts

No.	Description	Part no.	Note
1	Bracket set	SFD-BR100	With 2 countersunk head screws (M3)

Component Parts

No.	Description	Material	Note
1	Element	Case: Clear resin	
2	Cover	Resin	
3	Bracket	Resin	
4	O-ring	Rubber	

Replacement Parts

No.	Description	Part no.	Note
1	Bracket set	SFD-BR100	With 2 countersunk head screws (M3)

Component Parts

No.	Description	Material	Note
1	Element	Case: Clear resin	
2	Cover	Aluminum alloy	
3	Fitting body	Resin	
4	Seal	Rubber	
5	Cushion	Rubber	
6	Stopper	Stainless steel alloy	
7	Cassette	Stainless steel alloy	
8	Bracket	Stainless steel alloy	
9	O-ring A	Rubber	
10	O-ring B	Rubber	
11	Rod cover	Stainless steel alloy	
12	Tie-rod	Stainless steel alloy	
13	Cap nut	General type steel	Nickel plated
14	Plain washer	General type steel	Nickel plated

Replacement Parts

No.	Description	Part no.	Note
1	Element set	SFD-EL200	With 3 O-rings

Component Parts

No.	Description	Material	Note
1	Element	Case: Clear resin	
2	Cover	Aluminum alloy	
3	Fitting body	Stainless steel alloy	
4	Bracket	Stainless steel alloy	
5	O-ring A	Rubber	
6	O-ring B	Rubber	
7	Rod cover	Stainless steel alloy	
8	Tie-rod	Stainless steel alloy	
9	Cap nut	General type steel	Nickel plated
10	Plain washer	General type steel	Nickel plated

Replacement Parts

No.	Description	Part no.	Note
1	Element set	SFD-EL200	With 3 O-rings

Series SFD

Dimensions

SFD100-C□

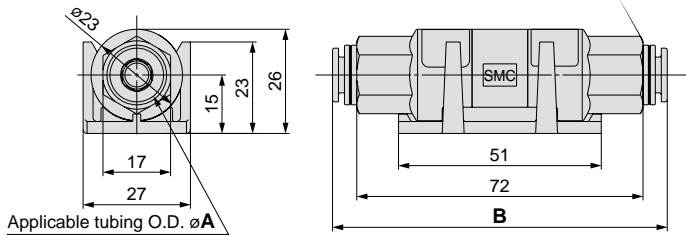

SFD100-C□ Dimensions

Model	A	B	
SFD100-	C04	4	83
	C06	6	83
	C08	8	84

Bracket mounting dimensions

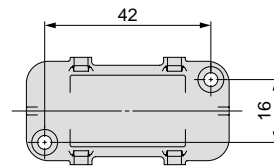

SFD100-□02

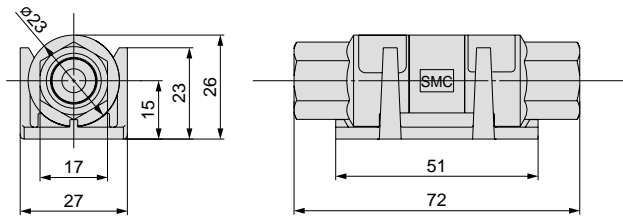

Hole shape for bracket mounting

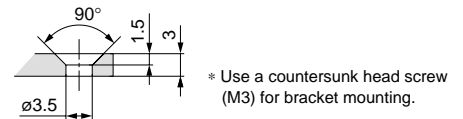

SFD200-C□

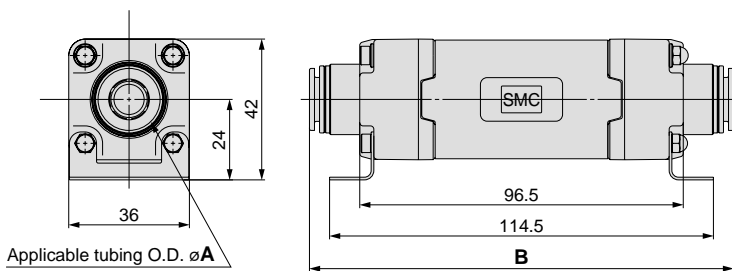

SFD200-C□ Dimensions

Model	A	B	
SFD200-	C08	8	127
	C10	10	128
	C12	12	128

Bracket mounting dimensions

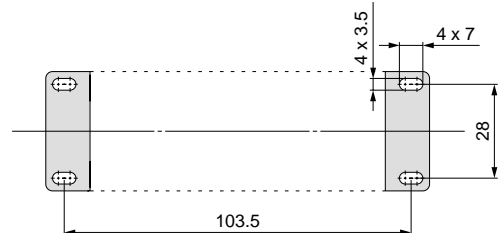

SFD200-□02

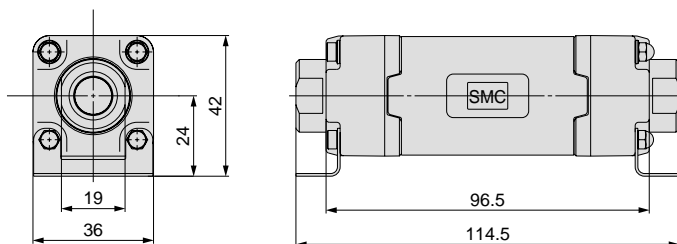

Series SFD Made to Order 1

Contact SMC for detailed specifications, delivery and prices.



1 Metal Case

SFD 1 0 1 - 02

Clean air filter

Size

Symbol	Max. flow rate
1	100 l/min (ANR)

* The SFD2 is not applicable.

Case material

Symbol	Material
1	Aluminum
2	Stainless steel

Port size

Symbol	Connection size
02	Rc 1/4
N02	NPT 1/4
F02	G 1/4

* The metal case is not available with a clean one-touch fitting.

* The bracket is provided as standard.

Metal case that is suitable for an atmosphere exposed to organic solvents and chemicals.



Specifications

The specifications are the same as the standard product. Refer to "Specifications" on page 1.

Flow Characteristics

The flow characteristics are the same as the SFD100-02. Refer to "Flow Characteristics" on page 2.

Construction

SFD101-02

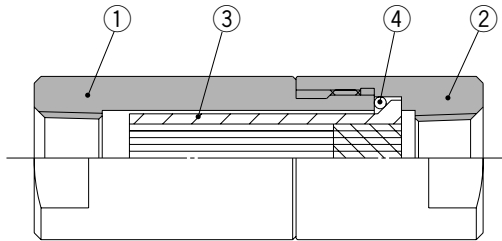

SFD102-02

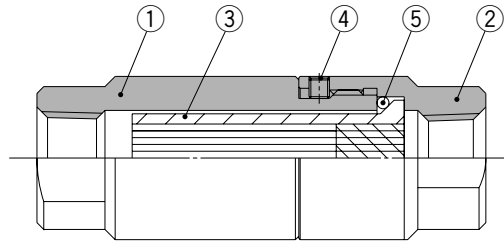

Component Parts

No.	Description	Material	Note
1	Case	Aluminum alloy	
2	Cover	Aluminum alloy	
3	Element	Case: Clear resin	
4	O-ring	Rubber	

Component Parts

No.	Description	Material	Note
1	Case	Stainless steel alloy	
2	Cover	Stainless steel alloy	
3	Element	Case: Clear resin	
4	Hex. socket head set screw	Stainless steel alloy	
5	O-ring	Rubber	

Replacement Parts

No.	Description	Part no.	Note
1	Element set	SFD-EL101	With O-ring
2	Bracket	SFD-BR101	

Replacement Parts

No.	Description	Part no.	Note
1	Element set	SFD-EL101	With O-ring
2	Bracket	SFD-BR101	

Dimensions

SFD101-02

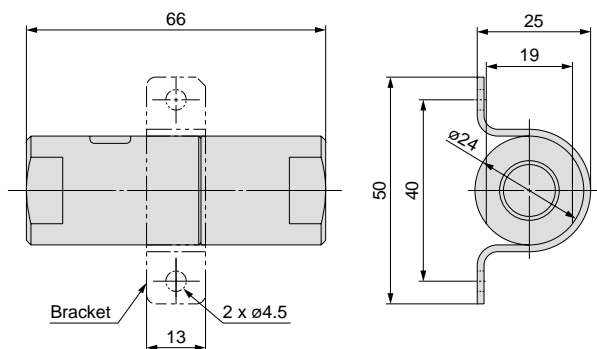

SFD102-02

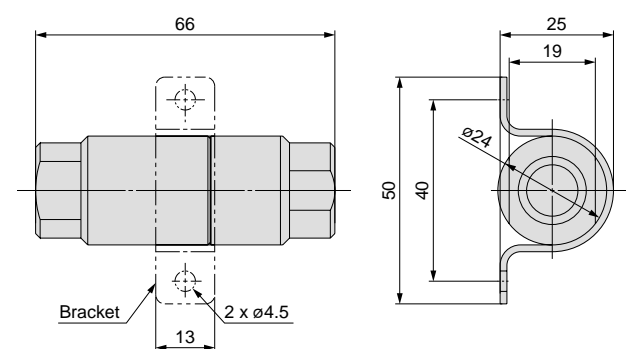

Series SFD Made to Order 2

Contact SMC for detailed specifications, delivery and prices.



2 Different Diameters for IN and OUT Ports

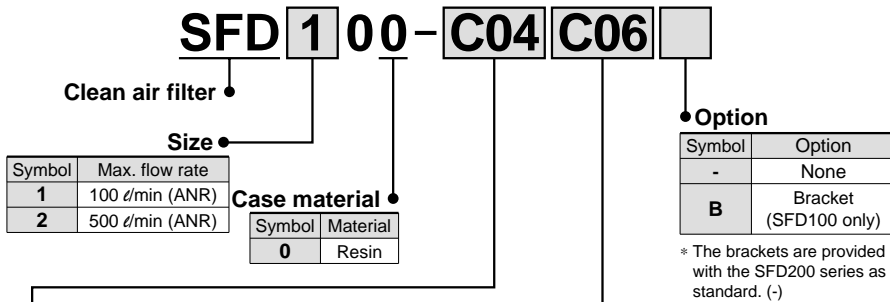

IN side connection symbol

IN side connection symbol	Connection size	
C04	ø4	Clean one-touch fitting (KP series)
C06	ø6	
C08	ø8	
C10	ø10	
C12	ø12	
O2		Rc 1/4
N02		NPT 1/4
F02		G 1/4

OUT side connection symbol

OUT side connection symbol	Connection size	
C04	ø4	Clean one-touch fitting (KP series)
C06	ø6	
C08	ø8	
C10	ø10	
C12	ø12	
O2		Rc 1/4
N02		NPT 1/4
F02		G 1/4

* IN/OUT combination is the below table.

SFD100 Different Diameter Combinations

IN port size	OUT port size					
	C04	C06	C08	O2	N02	F02
C04	●	—	●	●	●	●
C06	●	●	●	●	●	●
C08	—	●	●	●	●	●
O2	●	●	●	—	—	—
N02	●	●	●	—	—	—
F02	●	●	●	—	—	—

* The symbol "—" stands for unavailable combination.

SFD200 Different Diameter Combinations

IN port size	OUT port size					
	C08	C10	C12	O2	N02	F02
C08	●	—	●	●	●	●
C10	●	●	●	●	●	●
C12	—	●	●	●	●	●
O2	●	●	●	—	—	—
N02	●	●	●	—	—	—
F02	●	●	●	—	—	—

* The symbol "—" stands for unavailable combination.

Specifications

The specifications are the same as the standard models. Refer to "Specifications" on page 1.

Flow Characteristics

When the IN and OUT ports have different diameters, the flow characteristics will be the same as those of the port with the smaller diameter. Refer to "Flow Characteristics" for the smaller diameter from the charts of standard products on page 2.

Construction

The construction and materials are the same as the standard product. Refer to "Construction" on page 3.

Dimensions

SFD100 different diameters

One-touch fitting dimensions

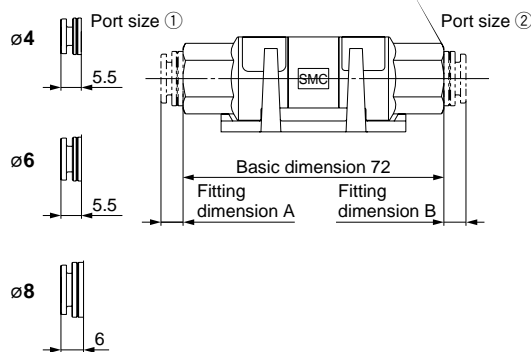

Model	Port size ①	Port size ②	Total length
SFD100-	C04 (C06)	C06 (C04)	83 (A + 72 + B)
	C04 (□02)	□02 (C04)	77.5 (72 + A)
	C06 (C08)	C08 (C06)	83.5 (A + 72 + B)
	C06 (□02)	□02 (C06)	77.5 (72 + A)
	C08 (□02)	□02 (C08)	78 (72 + A)

SFD200 different diameters

One-touch fitting dimensions

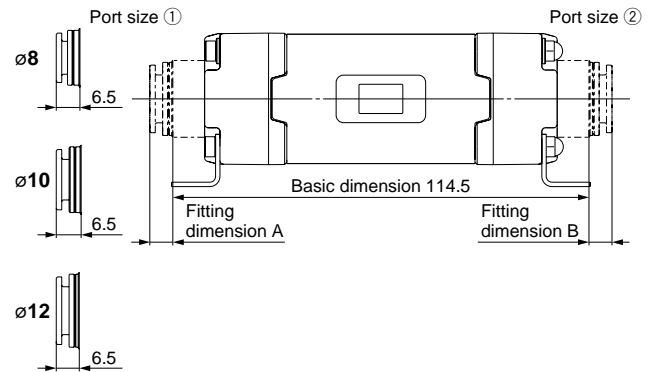

Model	Port size ①	Port size ②	Total length
SFD200-	C08 (C10)	C10 (C08)	127.5 (A + 114.5 + B)
	C08 (□02)	□02 (C08)	121 (114.5 + A)
	C10 (C12)	C12 (C10)	127.5 (A + 114.5 + B)
	C10 (□02)	□02 (C10)	121 (114.5 + A)
	C12 (□02)	□02 (C12)	121 (114.5 + A)

Related Products

<Pre-filters for *Series SFD*>

For details, refer to SMC's "Best Pneumatics" catalogue.

Mist Separator *Series AM*



Series AM

Model	AM150	AM250
Rated flow (ℓ/min (ANR))	300	750
Port size (Rc, G, NPT)	1/8, 1/4, 3/8	1/4, 3/8, 1/2

Specifications

Fluid	Compressed air
Max. operating pressure	1.0 MPa
Min. operating pressure ^{Note)}	0.05 MPa
Proof pressure	1.5 MPa
Ambient temperature	5 to 60°C
Nominal filtration rating	0.3 μm (95% particle size collection)

Note) With auto drain: 0.1 MPa (N.O. type), 0.15 MPa (N.C. type)

Micro Mist Separator *Series AMD*



Series AMD

Model	AMD150	AMD250
Rated flow (ℓ/min (ANR))	200	500
Port size (Rc, G, NPT)	1/8, 1/4, 3/8	1/4, 3/8, 1/2

Specifications

Fluid	Compressed air
Max. operating pressure	1.0 MPa
Min. operating pressure ^{Note)}	0.05 MPa
Proof pressure	1.5 MPa
Ambient temperature	5 to 60°C
Nominal filtration rating	0.01 μm (95% particle size collection)

Note) With auto drain: 0.1 MPa (N.O. type), 0.15 MPa (N.C. type)

Super Mist Separator *Series AME*



Series AME

Model	AME150	AME250
Rated flow (ℓ/min (ANR))	200	500
Port size (Rc, G, NPT)	1/8, 1/4, 3/8	1/4, 3/8, 1/2

Specifications

Fluid	Compressed air
Max. operating pressure	1.0 MPa
Min. operating pressure	0.05 MPa
Proof pressure	1.5 MPa
Ambient temperature	5 to 60°C
Nominal filtration rating	0.01 μm (95% particle size collection)

Odour Removal Filter *Series AMF*



Series AMF

Model	AMF150	AMF250
Rated flow (ℓ/min (ANR))	200	500
Port size (Rc, G, NPT)	1/8, 1/4, 3/8	1/4, 3/8, 1/2

Specifications

Fluid	Compressed air
Max. operating pressure	1.0 MPa
Min. operating pressure	0.05 MPa
Proof pressure	1.5 MPa
Ambient temperature	5 to 60°C
Nominal filtration rating	0.01 μm (95% particle size collection)

Related Products

Ionizer *Series IZS31*

Controlled ion balance by sensor

- Rapid elimination of static electricity by a feedback sensor
- Ion balance control by an autobalance sensor



Ionizer



Feedback sensor

Autobalance sensor

Ionizer model		IZS31-□□ (NPN spec.)	IZS31-□□P (PNP spec.)
Ion generation method		Corona discharge type	
Method of applying voltage		Sensing DC, Pulse DC, DC	
Output for emitting electricity		±7000 V	
Ion balance ^{Note 1)}		±30 V (in the case of stainless steel electrode needle ±100 V)	
Air purge	Fluid	Air (clean and dry)	
	Operating pressure	0.7 MPa or less	
	Connecting tubing O.D.	ø4	
Electrode needle material		Tungsten, Silicon, Stainless steel	

Note 1) For the case where air purge is performed between a charged object and an ionizer at a distance of 300 mm.

Note 2) When measuring the potential of a charged object with a feedback sensor, the relationship between measured charge potential and sensor monitor output voltage and the sensor detecting range will differ according to the sensor installation distance.

Electrode Cartridge Number, Weight

Bar length (mm)	300	380	620	780	1100	1260	1500	1900	2300
Electrode cartridge number	3	4	7	9	13	15	18	23	28
Weight (g)	470	530	720	850	1100	1220	1410	1730	2040

Clean Regulator *Series SR*

Series SRP1000



Stainless steel regulator controlled for contamination

Series SRH



Series SRP1000

Series	Port size		Wetted parts material	
	M5	1/8	Body	Diaphragm
SRP1000	●	●	Stainless steel 316L (Stainless steel 316 for wetted parts)	Wetted parts PTFE + Fluorine rubber (Grade A) Fluorine rubber (Grade B)

Series SRH

Series	Port size Rc (PT)						Wetted parts material	
	1/8	1/4	3/8	1/2	9/16-18UNF	7/8-14UNF	Body	Diaphragm
SRH3000	●	●	●	●	●	●	Stainless steel 316L (Stainless steel 316 for wetted parts)	Wetted parts PTFE + Fluorine rubber (Grade A) Fluorine rubber (Grade B)
SRH4000	●	●	●	●	●	●		

Clean Gas Filter *Series SF*

Nominal filtration rating 0.01 μm

Series SFA



Series SFB



Series SFC



Cartridge Type

Series	Type	Main material			Thread type	Port size	
		Element	Housing	Seal		M5	1/4
100 SFA 200 300	Disc	PTFE + Polyester	Stainless steel 316 (Electro-polishing)	Fluorine rubber (FPM)	Rc (PT)	●	●
SFB100	Straight	PTFE + PFA			NPT	●	●
					TSJ	●	●
					UOJ	●	●

Disposable Type

Series	Type	Main material			Thread type	Port size	
		Element	Housing	Seal		1/4	3/8
SFB300	Straight	PTFE + PFA	Stainless steel 316 (Electro-polishing)	—	Rc (PT)	●	●
SFC100	Multiple disc	PTFE + PVDF		O-ring PTFE	URJ	●	●





Series SFD

Safety Instructions

These safety instructions are intended to prevent a hazardous situation and/or equipment damage. These instructions indicate the level of potential hazard by labels of "Caution", "Warning" or "Danger". To ensure safety, be sure to observe ISO 4414 ^{Note 1)}, JIS B 8370 ^{Note 2)} and other safety practices.

■ Explanation of the Labels

Labels	Explanation of the labels
 Danger	In extreme conditions, there is a possible result of serious injury or loss of life.
 Warning	Operator error could result in serious injury or loss of life.
 Caution	Operator error could result in injury ^{Note 3)} or equipment damage. ^{Note 4)}

Note 1) ISO 4414: Pneumatic fluid power – General rules relating to systems

Note 2) JIS B 8370: General Rules for Pneumatic Equipment

Note 3) Injury indicates light wounds, burns and electrical shocks that do not require hospitalisation or hospital visits for long-term medical treatment.

Note 4) Equipment damage refers to extensive damage to the equipment and surrounding devices.

■ Selection/Handling/Applications

1. The compatibility of the pneumatic equipment is the responsibility of the person who designs the pneumatic system or decides its specifications.

Since the products specified here are used in various operating conditions, their compatibility for the specific pneumatic system must be based on specifications or post analysis and/or tests to meet the specific requirements. The expected performance and safety assurance are the responsibility of the person who has determined the compatibility of the system. This person should continuously review the suitability of all items specified, referring to the latest catalogue information with a view to giving due consideration to any possibility of equipment failure when configuring a system.

2. Only trained personnel should operate pneumatically operated machinery and equipment.

Compressed air can be dangerous if handled incorrectly. Assembly, handling or repair of the systems using pneumatic equipment should be performed by trained and experienced operators. (Understanding JIS B 8370 General Rules for Pneumatic Equipment, and other safety rules are included.)

3. Do not service machinery/equipment or attempt to remove components until safety is confirmed.

1. Inspection and maintenance of machinery/equipment should only be performed once measures to prevent falling or runaway of the driven objects have been confirmed.
2. When equipment is removed, confirm the safety process as mentioned above. Turn off the supply pressure for this equipment and exhaust all residual compressed air in the system, and release all the energy (liquid pressure, spring, condenser, gravity).
3. Before machinery/equipment is restarted, take measures to prevent quick extension of a cylinder piston rod, etc.

4. If the equipment will be used in the following conditions or environment, please contact SMC first and be sure to take all necessary safety precautions.

1. Conditions and environments beyond the given specifications, or if product is used outdoors.
2. Installation on equipment in conjunction with atomic energy, railway, air navigation, vehicles, medical equipment, food and beverages, recreation equipment, emergency stop circuits, clutch and brake circuits in press applications, or safety equipment.
3. An application which has the possibility of having negative effects on people, property, requiring special safety analysis.
4. If the products are used in an interlock circuit, prepare a double interlock style circuit with a mechanical protection function for the prevention of a breakdown. And, examine the devices periodically if they function normally or not.

■ Exemption from Liability

1. SMC, its officers and employees shall be exempted from liability for any loss or damage arising out of earthquakes or fire, action by a third person, accidents, customer error with or without intention, product misuse, and any other damages caused by abnormal operating conditions.

2. SMC, its officers and employees shall be exempted from liability for any direct or indirect loss or damage, including consequential loss or damage, loss of profits, or loss of chance, claims, demands, proceedings, costs, expenses, awards, judgments and any other liability whatsoever including legal costs and expenses, which may be suffered or incurred, whether in tort (including negligence), contract, breach of statutory duty, equity or otherwise.

3. SMC is exempted from liability for any damages caused by operations not contained in the catalogues and/or instruction manuals, and operations outside of the specification range.

4. SMC is exempted from liability for any loss or damage whatsoever caused by malfunctions of its products when combined with other devices or software.



Series SFD

Specific Product Precautions 1

Be sure to read this before handling. Refer to the back of page 1 for Safety Instructions and "Precautions for Handling Pneumatic Devices (M-03-E3A) for Common Precautions.

Selection

Warning

1. Thoroughly and carefully confirm the purpose of use, required specifications and operating conditions (fluid, pressure, flow rate, nominal filtration rating and environment) then select a model within the specifications.
2. The product is not certified under the High Pressure Gas Safety law, so for nitrogen, its maximum operating pressure will be 0.99 MPa (gauge pressure).
3. Contact SMC beforehand if the product will be used in an application such as a caisson shield, breathing, food and/or medical treatment that affects the human body directly or indirectly.

Mounting

Warning

1. **Instruction manual**
Mount the product after reading and understanding the instruction manual. Keep it in a location where it can easily be found.
2. **Flushing**
Flush the piping line when the filter is used for the first time or has been replaced. In the event of connecting such as piping, flush (air blow) when using this product for the first time or replacing its elements in order to reduce the affect of the dust generated from the connection, etc. Flushing the line is also required to eliminate contamination resulting from the piping line installation. Therefore, be sure to flush the line before actually running the system. Fix all mounting parts for use.
3. **Use fittings with resin threads for the connection of fittings to the IN and OUT ports.**
Using fittings with metal threads could damage the IN and OUT ports.
4. **Connect tubing to the IN and OUT one-touch fittings in accordance with the precautions for one-touch fittings.**

Caution

1. **Connect the piping in accordance with the flow direction marked on the case.**
If connected in reverse, the element could break.
2. **The mounting orientation does not affect the performance, but if excessive force is applied to the SFD100 series, the body may become disconnected from the bracket.**
Therefore, take particular care about the mounting orientation.

Caution on Installation

Warning

1. **The material of the element is polycarbonate.**
The material is resistant to wiping with alcohol, but is not suitable for atmospheres or places with organic solvents, chemicals, cutting oils, synthetic oils, ester base compressor oils, alkalis or thread locking agents.

Caution

1. **If the pressure difference (pressure drop) between the inlet and the outlet exceeds 0.1 MPa, it can cause damage to the product.**
2. **Do not install the product in a place where it can be affected by a pulsation (including surge pressure) of over 0.1 MPa.**
3. **Use caution regarding the particles that may be emitted from the outlet side of pneumatic equipment.**

Installation of pneumatic equipment on the outlet side can deteriorate the cleanliness because a particle will be generated from the equipment.

The mounting position of the pneumatic equipment needs to be considered.

4. **Set the air flow capacity with an initial pressure drop of 0.03 MPa or less. If the initial pressure drop is set to be high, its service life will be shorten due to clogging.**

5. **Determine the product by the maximum consumption flow rate.**

When using compressed air for an air blow application, calculate the maximum volume of air that will be consumed before selecting the SFD series product size.

6. **Generally, the following pollutant particles are contained in compressed air.**

[Pollutant particle substances contained in the compressed air]

- Moisture (drainage)
- Dusts and particles which are in the surrounding air
- Deteriorated oil which is discharged from the compressor
- Solid foreign matter such as rust and/or oil in the piping

1) The SFD series is not compatible with compressed air which contains fluids such as water and/or oil.

2) Install a dryer (IDFA, IDG series), mist separator (AM series), micro mist separator (AMD series), super mist separator (AME series), or odour removal filter (AMF series), etc., for the source of the air for the SFD series.

7. **Using with a flow-rate much higher than its specification could lead to exceeding the differential pressure the product can resist.**

Use the product within its specifications. Also, take care about the replacement period of the product, taking into consideration that the differential pressure of the filter will increase over time.



Series SFD Specific Product Precautions 2

Be sure to read this before handling. Refer to the back of page 1 for Safety Instructions and "Precautions for Handling Pneumatic Devices (M-03-E3A) for Common Precautions.

Piping

⚠ Caution

1. Unpacking the sealed package

Since the filter is sealed in an antistatic double bag, the inner package should be unpacked in a clean atmosphere (such as a clean room).

2. Apply a wrench to the 2 chamfered flats or hexagon portion on the IN side or the OUT side to prevent the housing from rotating.

3. Always tighten threads with the proper tightening torque.

When attaching fittings to the product, tighten with the proper tightening torque shown below.

Material	Tightening torque (N·m)
Resin	2 to 3
Metal	12 to 14

4. Check the arrow mark on the case which shows the flow direction to connect the IN and OUT ports correctly.

If connected in reverse, the element could break.

Maintenance

⚠ Warning

1. Follow the maintenance procedures in the instruction manual. If handled incorrectly, equipment or device can be damaged or cause a malfunction.

2. When removing the product, exhaust the air and ensure the air is released to atmosphere before removing it.

3. When the element comes to the end of its life, immediately replace it with a new filter or replacement element (cartridge type).

Service life of element

The service life of the element ends when either of the following two conditions occurs.

- 1) After 1 year of usage has elapsed.
- 2) When the pressure drop reaches 0.1 MPa even though the operating period has been less than 1 year.

Operating Environment

⚠ Warning

1. Do not operate under the conditions listed below due to a risk of malfunction.

In locations having corrosive gases, organic solvents, and chemical solutions, or in locations in which these elements are likely to adhere to the equipment.

In locations in which salt water, water, or water vapour could come in contact with the equipment.

In locations that are exposed to direct sunlight. (Shield the equipment from sunlight to prevent its resin material from ultraviolet ray degradation or overheating.)

In locations that have a heat source and poor ventilation. (Shield the equipment from heat sources to protect it from softening degradation due to radiated heat.)

In locations that are exposed to shocks and vibrations.

In locations with high humidity or a large amounts of dust.

2. When the product is used for blowing, use caution to prevent the work from being damaged by entrained air from the surrounding area.

When the compressed air is used for air blow, the exhausted air from the blow nozzle may have taken in airborne foreign matter (such as solid particle, fluid particle) from the surrounding air. The foreign matter will be sprayed onto the work, and the airborne foreign matter may adhere to it. Therefore, use caution for the surrounding environment.

Other Tube Brands

⚠ Caution

1. When tubing of brands other than SMC's are used, verify that the tubing O.D. satisfies the following accuracy;

- 1) Polyolefin tube: Within ± 0.1 mm
- 2) Polyurethane tubing: Within $+0.15$ mm, within -0.2 mm
- 3) Nylon tubing: Within ± 0.1 mm
- 4) Soft nylon tubing: Within ± 0.1 mm

Do not use tubing which does not meet these outside diameter tolerances. It may not be possible to connect them, or they may cause other trouble, such as air leakage or the tube pulling out after connection.

The recommended tube for the clean fitting is polyolefin tube. Other tubes can satisfy the performance in terms of leakage, tensile strength, etc., but may impair the cleanliness. Note this point for use.