

Motorless Type

Electric Actuators

RoHS

Your motor and driver can be used together!
Manufacturers of compatible
motors: 15 companies

Mitsubishi Electric Corporation	YASKAWA Electric Corporation
SANYO DENKI CO., LTD.	OMRON Corporation
Panasonic Corporation	FANUC CORPORATION
NIDEC SANKYO CORPORATION	KEYENCE CORPORATION
FUJI ELECTRIC CO., LTD.	ORIENTAL MOTOR Co., Ltd.
FASTECH Co., Ltd.	Rockwell Automation, Inc. (Allen-Bradley)
Beckhoff Automation GmbH	Siemens AG
Delta Electronics, Inc.	

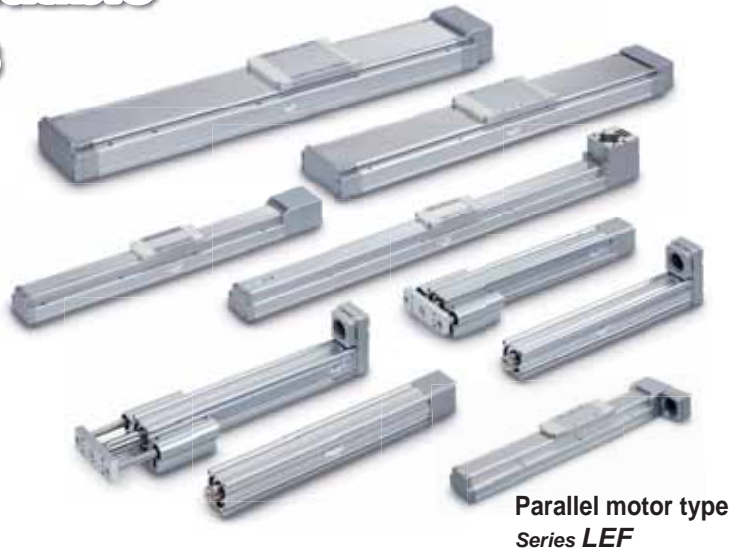

Parallel motor type
Series LEF

Slider Type Series LEF

Ball Screw Drive/Series LEFS

Size	Stroke [mm]
25	50 to 800
32	50 to 1000
40	150 to 1200

Belt Drive/Series LEFB

Size	Stroke [mm]
25	300 to 2000
32	300 to 2500
40	300 to 3000

Belt drive
Series LEFB

Ball screw drive
Series LEFS



Parallel motor type

High Rigidity Slider Type Series LEJ

Ball Screw Drive/Series LEJS

Size	Stroke [mm]
40	200 to 1200
63	300 to 1500

Ball screw drive
Series LEJS



Rod Type Series LEY

Size	Stroke [mm]
25	30 to 400
32	30 to 500
63	100 to 800



Guide Rod Type Series LEYG

Size	Stroke [mm]
25	30 to 300
32	



Series LE□



CAT.EUS100-111Bb-UK

Motorless Type Electric Actuators

Compatible Motors by Manufacturer (100 W/200 W/400 W equivalent)

Manufacturer	Series	Type *1	Pulse input	CC-Link	SSCNET III	SSCNET III/H
Mitsubishi Electric Corporation	MELSERVO-JN	HF-KN	●			
	MELSERVO-J3	HF-KP	●	●	●	
	MELSERVO-J4	HG-KR	●			●
YASKAWA Electric Corporation	Σ-V	SGMJV	●			
SANYO DENKI CO., LTD.	SANMOTION R	R2	●			
OMRON Corporation	System G5	R88M-K	●			
Panasonic Corporation	MINAS-A4	MSMD	●			
	MINAS-A5	MSMD/MHMD	●			
FANUC CORPORATION	βis	β	●			
NIDEC SANKYO CORPORATION	S-FLAG	MA/MH/MM	●			
KEYENCE CORPORATION	SV	SV-M/SV-B	●			
FUJI ELECTRIC CO., LTD.	ALPHA5	GYS/GYB	●			
	FALDIC-α	GYS	●			
ORIENTAL MOTOR Co., Ltd.	AR	AR	●	●		
	AZ	AZ	●			
FASTECH Co., Ltd.	Ezi-SERVO	EzM	●			
Rockwell Automation, Inc. (Allen-Bradley)	MP-/VP-	MP/VP				
	TL	TLY-A				
Beckhoff Automation GmbH	AM	AM30/AM31				
	AM	AM80/AM81				
Siemens AG	1FK7	1FK7				
	1FK2	1FK2				
Delta Electronics, Inc.	ASDA-A2	ECMA	●			

*1 Motors should be applicable to the mounting dimensions and compatible motor types. Select a motor after checking the specifications of each model.

Additionally, when considering a motor other than those shown above, select a motor within the range of the specifications after checking the mounting dimensions.

*2 For details about compatible interfaces, refer to each manufacturer's catalogue.

*3 Recommended to use with Siemens cpu S7-1500.

Series Variations

The values in ● shows the equivalent motor capacity.

Series	Size				Page
	25	32	40	63	
Slider Type Ball screw drive Series LEFS	● 100 W	● 200 W	● 400 W		5
Slider Type Belt drive Series LEFB	● 100 W	● 200 W	● 400 W		32
High Rigidity Slider Type Ball screw drive Series LEJS			● 100 W	● 200 W	61
Rod Type Series LEY	● 100 W	● 200 W		● 400 W	85
Guide Rod Type Series LEYG	● 100 W	● 200 W			101

Motorless Type Electric Actuators



◎ Electric Actuator/Slider Type Ball Screw Drive

Series LEFS

Model Selection.....	Page 5
How to Order	Page 13
Specifications	Page 14
Dimensions	Page 15
Motor Mounting	Page 21
Motor Mounting Parts.....	Page 23

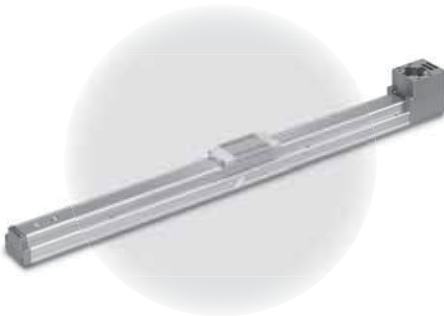

◎ Electric Actuator/Slider Type Belt Drive

Series LEFB

Model Selection.....	Page 32
How to Order	Page 37
Specifications	Page 38
Dimensions	Page 39
Motor Mounting	Page 51
Motor Mounting Parts.....	Page 52
Auto Switch	Page 55
Specific Product Precautions.....	Page 57



◎ Electric Actuator/High Rigidity Slider Type Ball Screw Drive

Series LEJS

Model Selection.....	Page 61
How to Order	Page 71
Specifications	Page 72
Dimensions	Page 73
Motor Mounting	Page 75
Motor Mounting Parts.....	Page 76
Auto Switch	Page 78
Specific Product Precautions.....	Page 81



◎ Electric Actuator/Rod Type

Series LEY

Model Selection.....	Page 85
How to Order	Page 91
Specifications	Page 92
Dimensions	Page 94



◎ Electric Actuator/Guide Rod Type

Series LEYG

Model Selection.....	Page 101
How to Order	Page 105
Specifications	Page 106
Dimensions	Page 107
Motor Mounting	Page 109
Motor Mounting Parts.....	Page 113
Auto Switch	Page 117
Specific Product Precautions.....	Page 120

Slider Type

Ball Screw Drive Series LEFS



Belt Drive Series LEFB



Model Selection

LEFS

LEFB

LEJS

LEY

LEYG

Motor Mounting

Motorless Type
 Electric Actuator/Slider Type
 Ball Screw Drive/Series **LEFS**
Model Selection

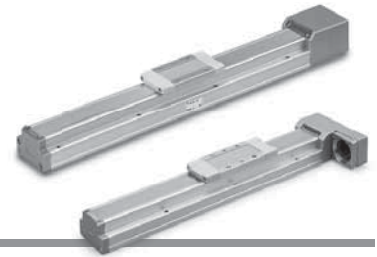

Selection Procedure



Selection Example

Operating conditions

- Workpiece weight: 55 [kg]
- Speed: 300 [mm/s]
- Acceleration/Deceleration: 3000 [mm/s²]
- Stroke: 200 [mm]
- Mounting position: Horizontal
- Incremental encoder
- Workpiece mounting condition:
- Settling time

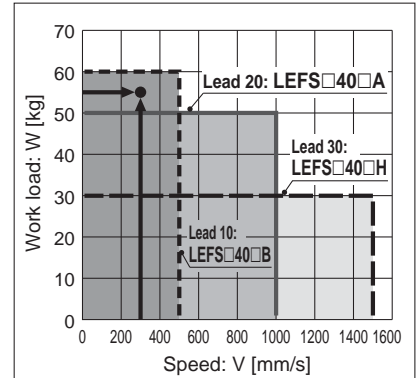
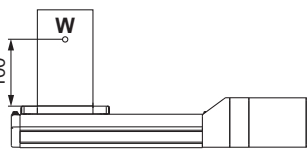

**<Speed-Work Load Graph>
(LEFS40)**

Step 1 Check the work load-speed. <Speed-Work Load Graph>

Select a model based on the workpiece mass and speed, within the range of the actuator specifications, while referring to the "Speed-Work Load Graph (Guide)" on page 6.

Selection example) The **LEFS40B-200** is provisionally selected based on the graph on the right.

* Refer to the motor manufacturers catalogue for details of the regeneration resistance.

Step 2 Check the cycle time.

Calculate the **cycle time** using the following calculation method.

Cycle time:

T can be found from the following equation.

$$T = T1 + T2 + T3 + T4 \text{ [s]}$$

- T1: Acceleration time and T3: Deceleration time can be found from the following equation.

$$T1 = V/a1 \text{ [s]}$$

$$T3 = V/a2 \text{ [s]}$$

- T2: Constant speed time can be found from the following equation.

$$T2 = \frac{L - 0.5 \cdot V \cdot (T1 + T3)}{V} \text{ [s]}$$

- T4: Settling time varies depending on the motor type and load. The value below is recommended.

$$T4 = 0.05 \text{ [s]}$$

* The conditions for the settling time vary depending on the motor or driver to be used.

Calculation example)

T1 to T4 can be calculated as follows.

$$T1 = V/a1 = 300/3000 = 0.1 \text{ [s]}$$

$$T3 = V/a2 = 300/3000 = 0.1 \text{ [s]}$$

$$T2 = \frac{L - 0.5 \cdot V \cdot (T1 + T3)}{V}$$

$$= \frac{200 - 0.5 \cdot 300 \cdot (0.1 + 0.1)}{300}$$

$$= 0.57 \text{ [s]}$$

$$T4 = 0.05 \text{ [s]}$$

Therefore, the **cycle time** can be calculated as follows.

$$T = T1 + T2 + T3 + T4$$

$$= 0.1 + 0.57 + 0.1 + 0.05$$

$$= 0.82 \text{ [s]}$$

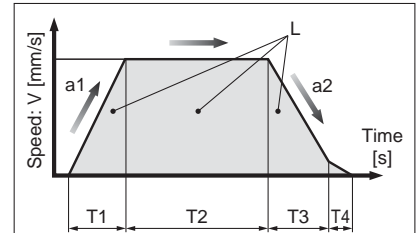

L : Stroke [mm]

... (Operating condition)

V : Speed [mm/s]

... (Operating condition)

a1: Acceleration [mm/s²]

... (Operating condition)

a2: Deceleration [mm/s²]

... (Operating condition)

T1: Acceleration time [s]

The time until the set speed is reached

T2: Constant speed time [s]

Time when the actuator is operating at a constant speed

T3: Deceleration time [s]

Time from the constant speed operation until movement stops

T4: Settling time [s]

Time until positioning is completed

Step 3 Check the guide moment.

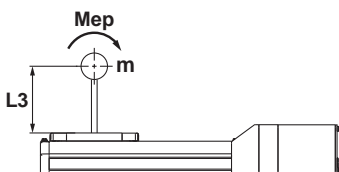

Based on the above calculation result, the **LEFS40B-200** can be selected.

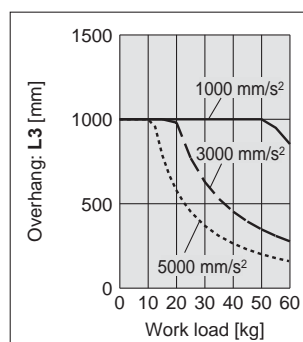

Speed-Work Load Graph (Guide)

* The values given below are within the actuator body specification ranges and should not be exceeded.
 * The allowable speed is restricted according to the stroke, refer to the "Allowable Stroke Speed" table below.

LEFS□25/Ball Screw Drive

Horizontal

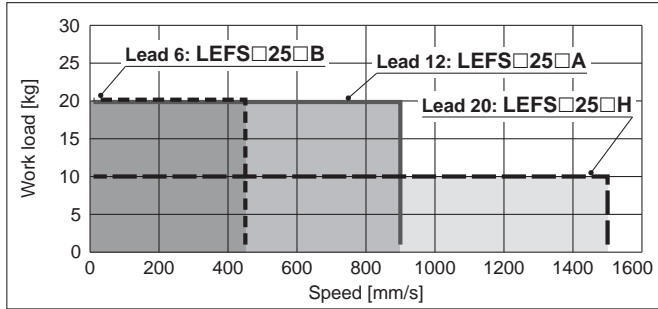

Vertical

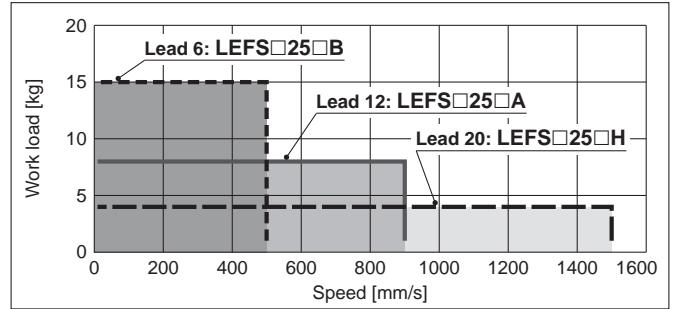

LEFS□32/Ball Screw Drive

Horizontal

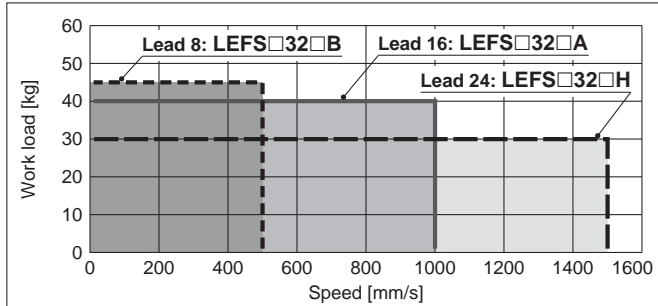

Vertical

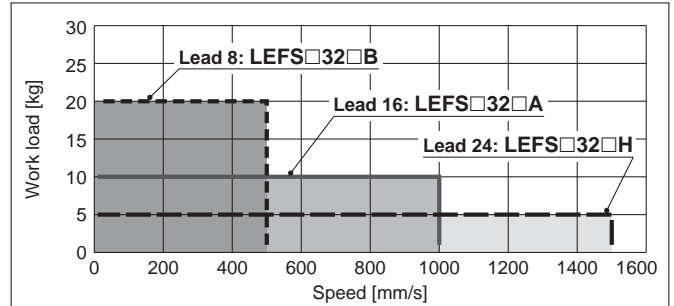

LEFS□40/Ball Screw Drive

Horizontal

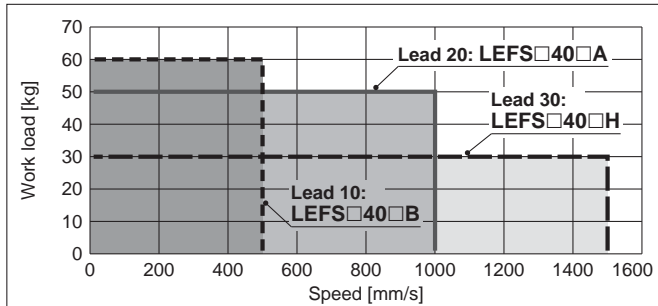

Vertical

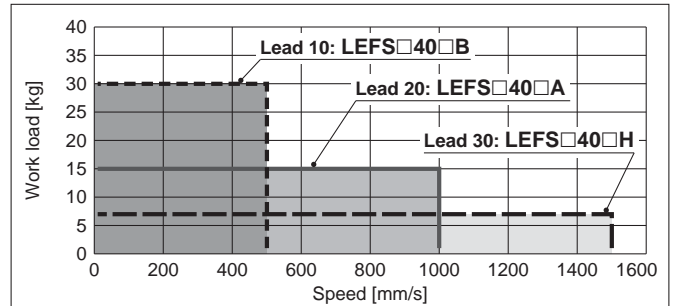

Allowable Stroke Speed

Model	AC servo motor	Lead		Stroke [mm]										
		Symbol	[mm]	Up to 100	Up to 200	Up to 300	Up to 400	Up to 500	Up to 600	Up to 700	Up to 800	Up to 900	Up to 1000	Up to 1100
LEFS25	100 W equivalent	H	20	1500			1100	860	700	550	—	—	—	—
		A	12	900			720	540	420	330	—	—	—	—
		B	6	450			360	270	210	160	—	—	—	—
		(Motor rotation speed)		(4500 rpm)			(3650 rpm)	(2700 rpm)	(2100 rpm)	(1650 rpm)	—	—	—	—
LEFS32	200 W equivalent	H	24	1500			1200	930	750	610	510	—	—	
		A	16	1000			800	620	500	410	340	—	—	
		B	8	500			400	310	250	200	170	—	—	
		(Motor rotation speed)		(3750 rpm)			(3000 rpm)	(2325 rpm)	(1875 rpm)	(1537 rpm)	(1275 rpm)	—	—	
LEFS40	400 W equivalent	H	30	—	1500			1410	1140	930	780	500	500	
		A	20	—	1000			940	760	620	520	440	380	
		B	10	—	500			470	380	310	260	220	190	
		(Motor rotation speed)		—	(3000 rpm)			(2820 rpm)	(2280 rpm)	(1860 rpm)	(1560 rpm)	(1320 rpm)	(1140 rpm)	

Model Selection

LEFS

LEFB

LEJS

LEY

LEYG

Motor Mounting

Series LEFS

Motorless Type

Work Load–Acceleration/Deceleration Graph (Guide)

LEFS□25□H/Ball Screw Drive

Horizontal

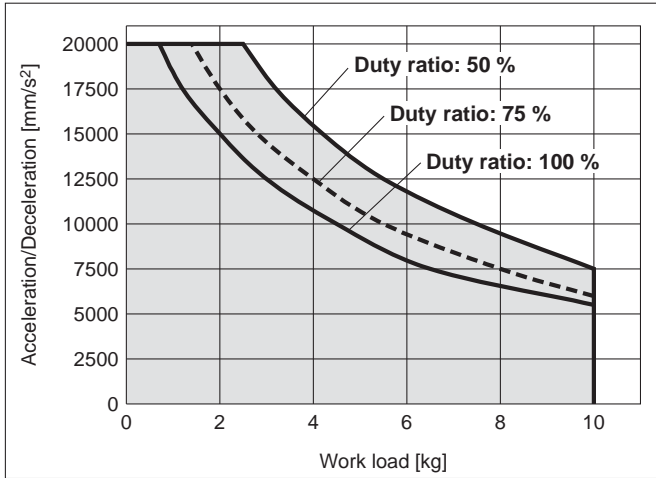

LEFS□25□H/Ball Screw Drive

Vertical

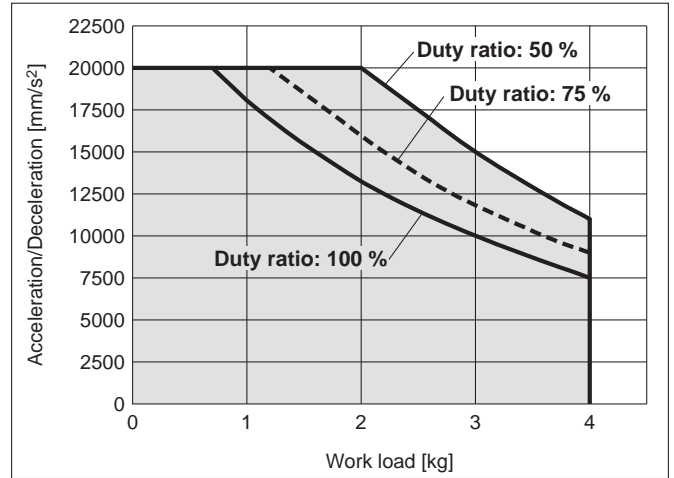

LEFS□25□A/Ball Screw Drive

Horizontal

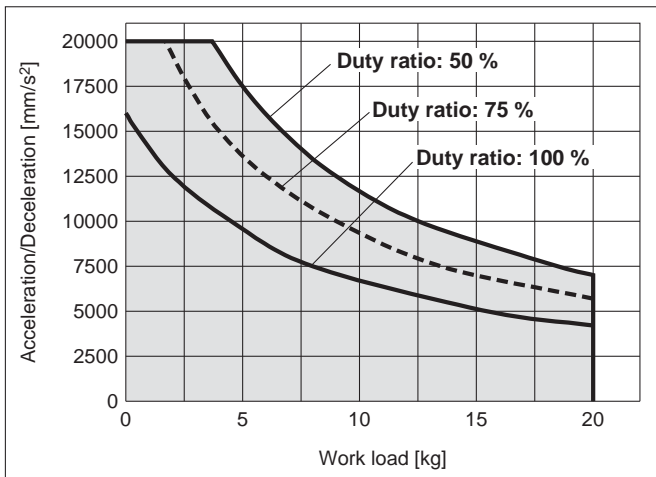

LEFS□25□A/Ball Screw Drive

Vertical

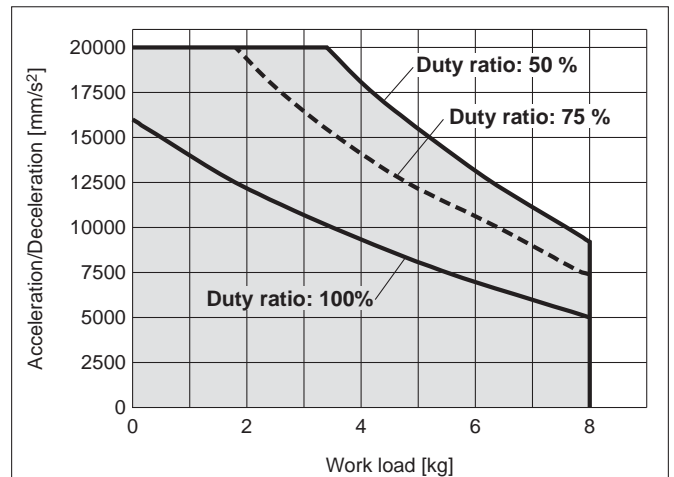

LEFS□25□B/Ball Screw Drive

Horizontal

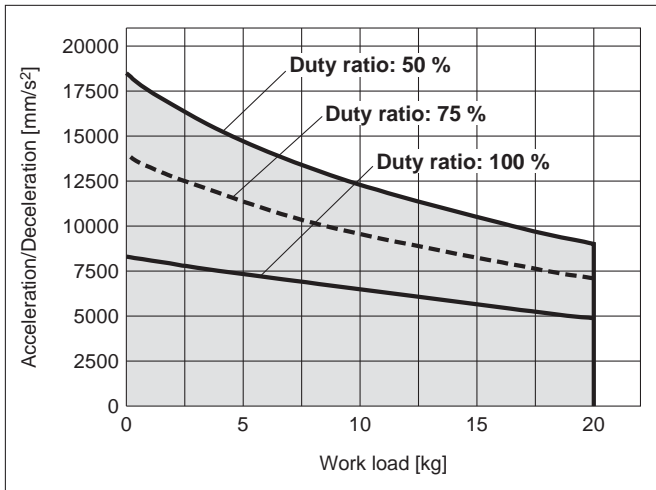

LEFS□25□B/Ball Screw Drive

Vertical

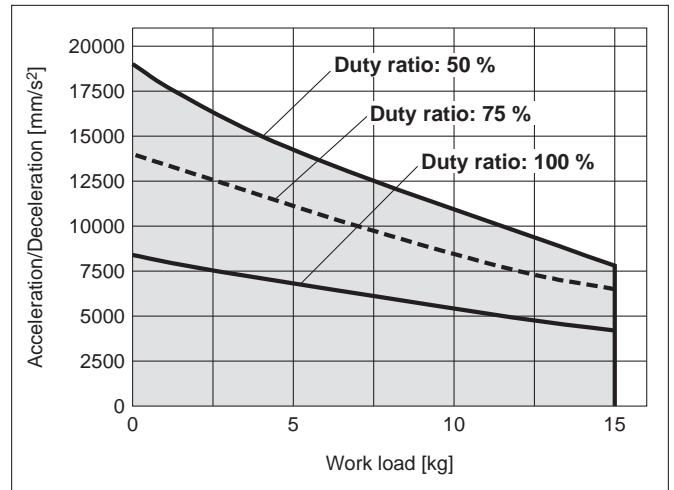

Work Load–Acceleration/Deceleration Graph (Guide)

LEFS□32□H/Ball Screw Drive

Horizontal

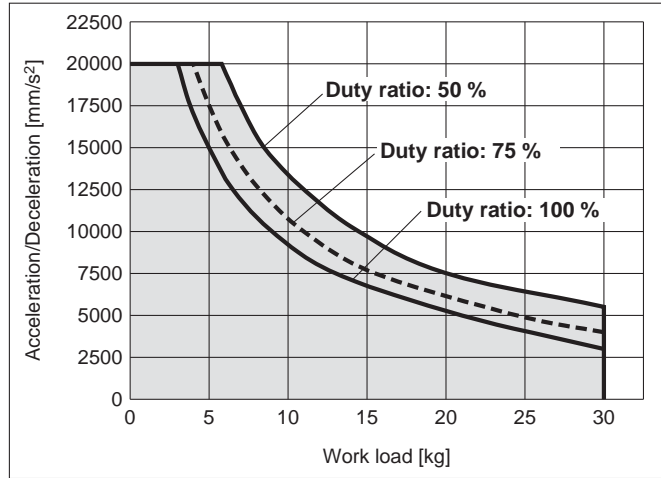

LEFS□32□H/Ball Screw Drive

Vertical

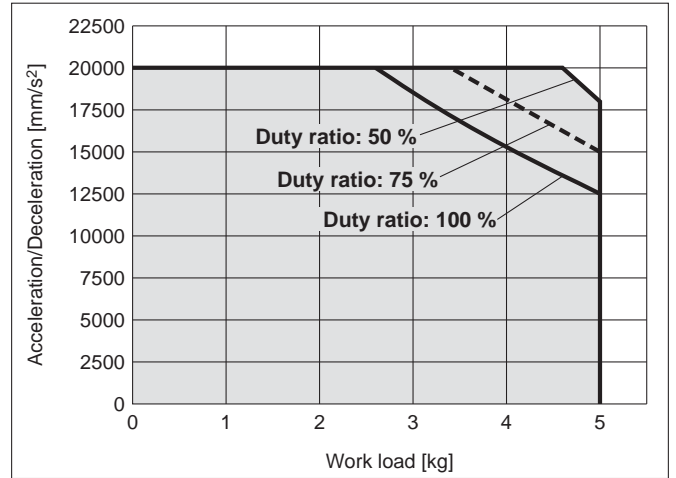

LEFS□32□A/Ball Screw Drive

Horizontal

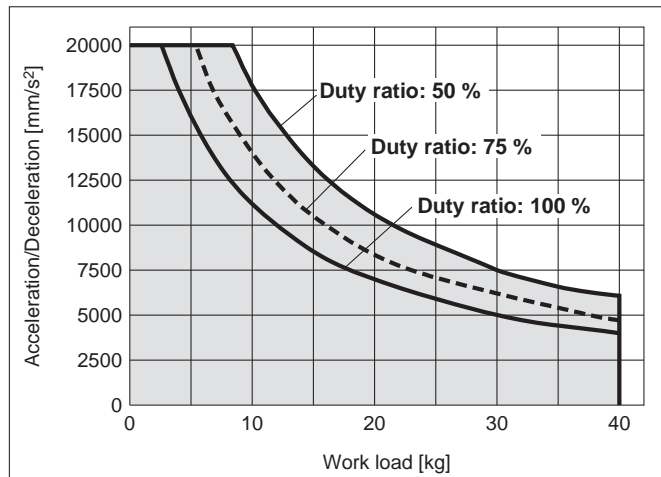

LEFS□32□A/Ball Screw Drive

Vertical

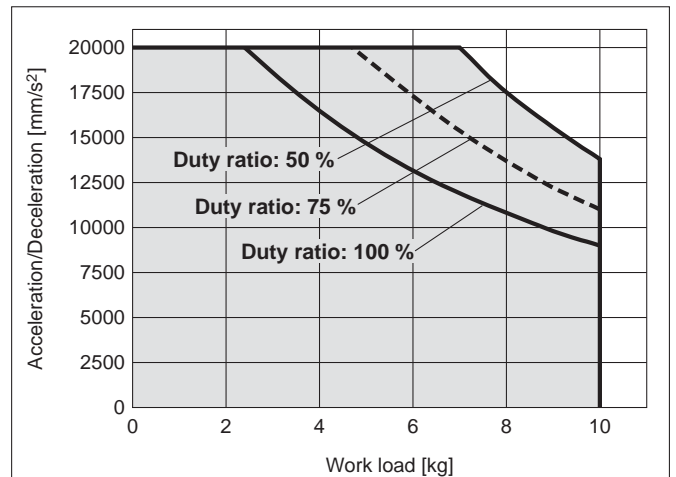

LEFS□32□B/Ball Screw Drive

Horizontal

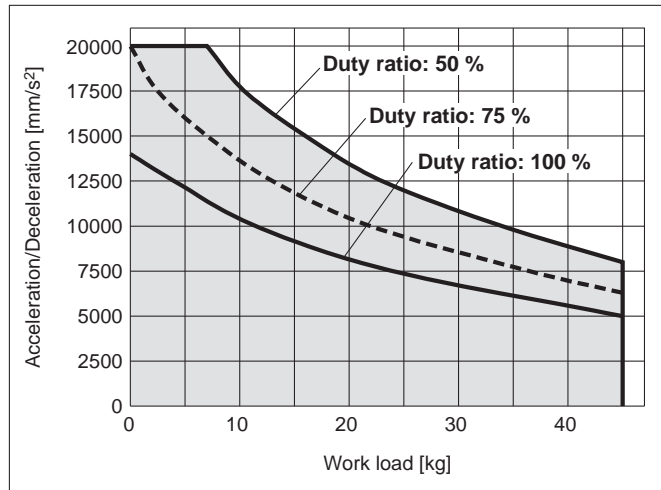

LEFS□32□B/Ball Screw Drive

Vertical

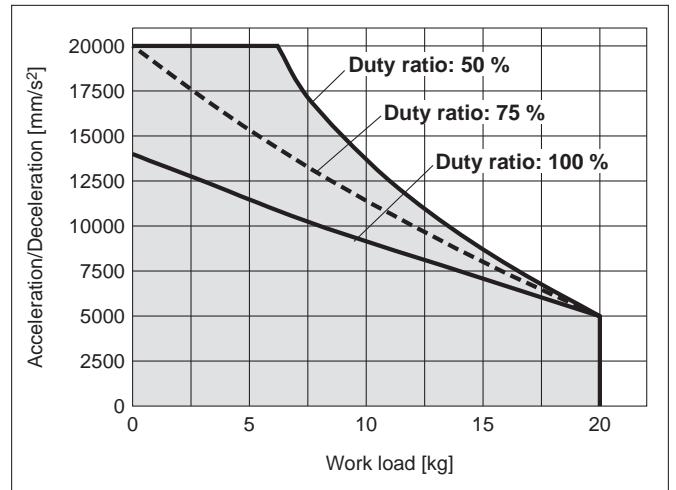

Model Selection

LEFS

LEFB

LEJS

LEY

LEYG

Motor Mounting

Series LEFS

Motorless Type

Work Load–Acceleration/Deceleration Graph (Guide)

LEFS□40□H/Ball Screw Drive

Horizontal

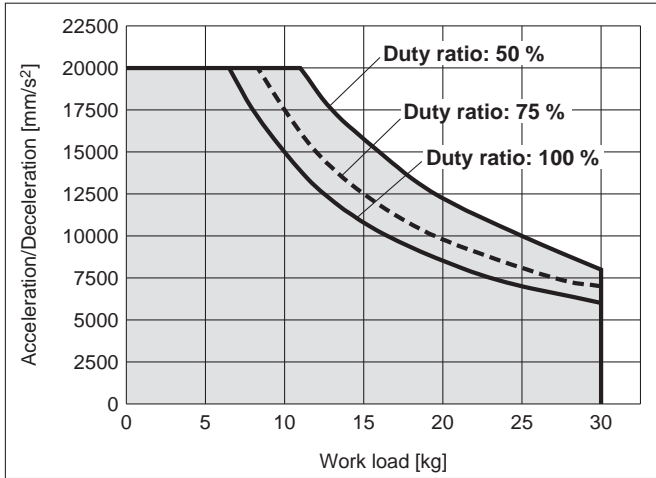

LEFS□40□H/Ball Screw Drive

Vertical

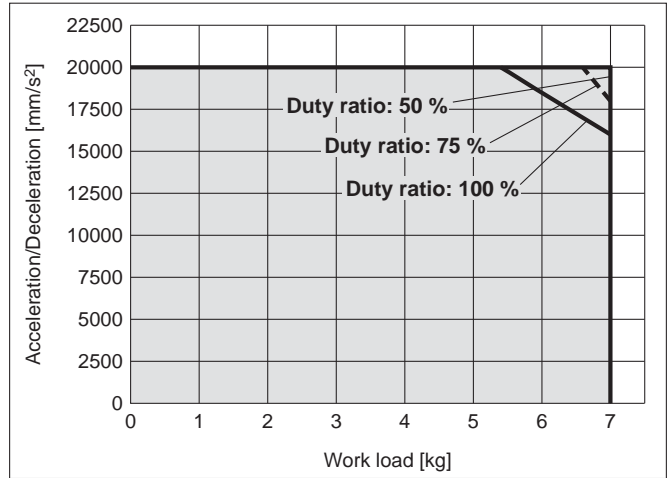

LEFS□40□A/Ball Screw Drive

Horizontal

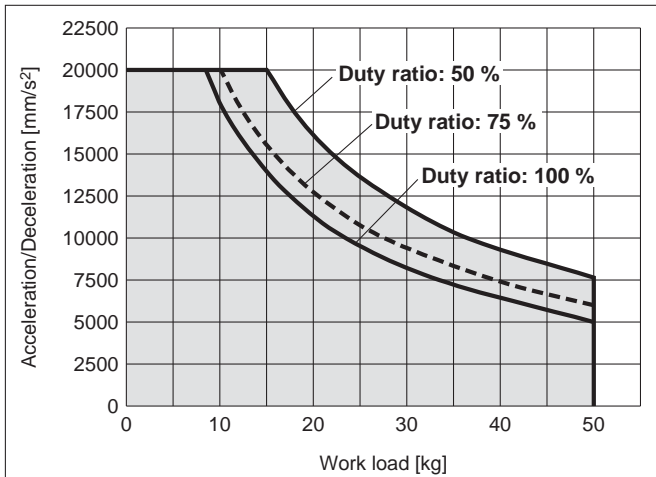

LEFS□40□A/Ball Screw Drive

Vertical

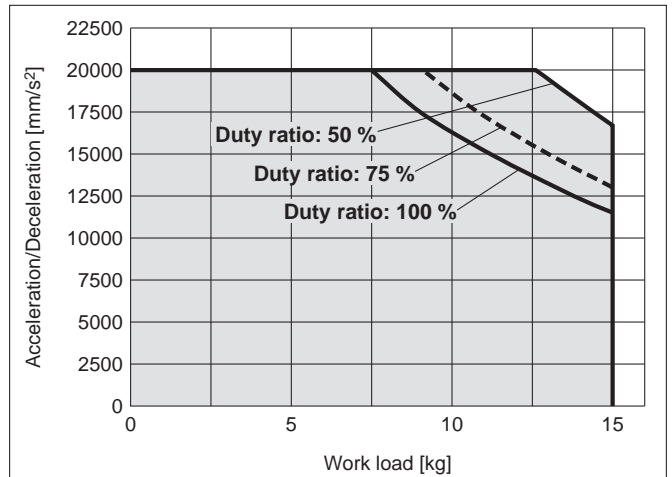

LEFS□40□B/Ball Screw Drive

Horizontal

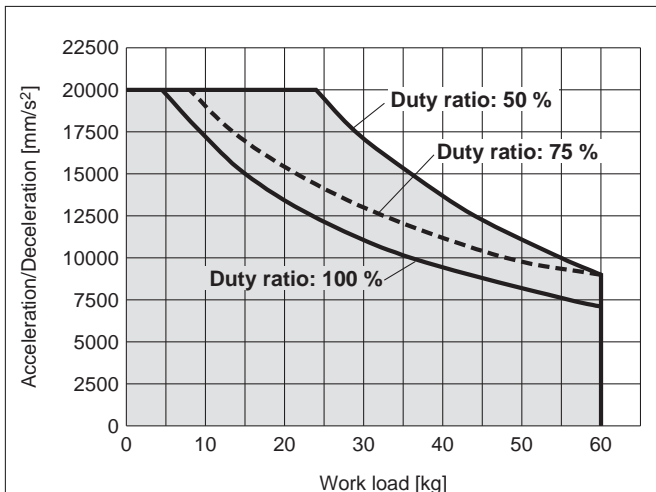

LEFS□40□B/Ball Screw Drive

Vertical

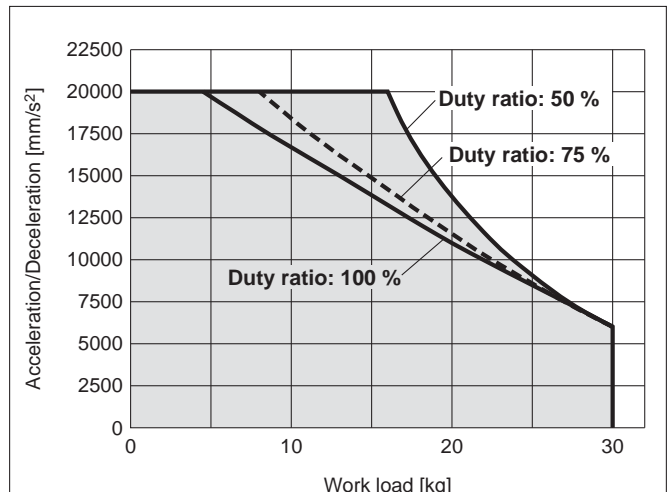

These graphs are examples of when the standard motor is mounted.
Determine the duty ratio after taking into account the load factor of the motor or driver to be used.

* This graph shows the amount of allowable overhang (guide unit) when the centre of gravity of the workpiece overhangs in one direction. When selecting the overhang, refer to "Calculation of Guide Load Factor" or the Electric Actuator Selection Software for confirmation, <http://www.smc.eu>

Dynamic Allowable Moment

Acceleration/Deceleration ——— 1000 mm/s² - - - 3000 mm/s² ······ 5000 mm/s² - - - - 10000 mm/s² - - - - 20000 mm/s²

Orientation		Model		
Load overhanging direction m : Work load [kg] Me: Dynamic allowable moment [N·m] L : Overhang to the work load centre of gravity [mm]		LEFS25□	LEFS32□	LEFS40□
Horizontal/Bottom	X 			
	Y 			
	Z 			
Wall mounted	X 			
	Y 			
	Z 			

Model Selection

LEFS

LEFB

LEJS

LEY

LEYG

Motor Mounting

Series LEFS

Motorless Type

* This graph shows the amount of allowable overhang (guide unit) when the centre of gravity of the workpiece overhangs in one direction. When selecting the overhang, refer to "Calculation of Guide Load Factor" or the Electric Actuator Selection Software for confirmation, <http://www.smc.eu>

Dynamic Allowable Moment

Acceleration/Deceleration ——— 1000 mm/s² - - - 3000 mm/s² ······ 5000 mm/s² - - - - 10000 mm/s² - - - - 20000 mm/s²

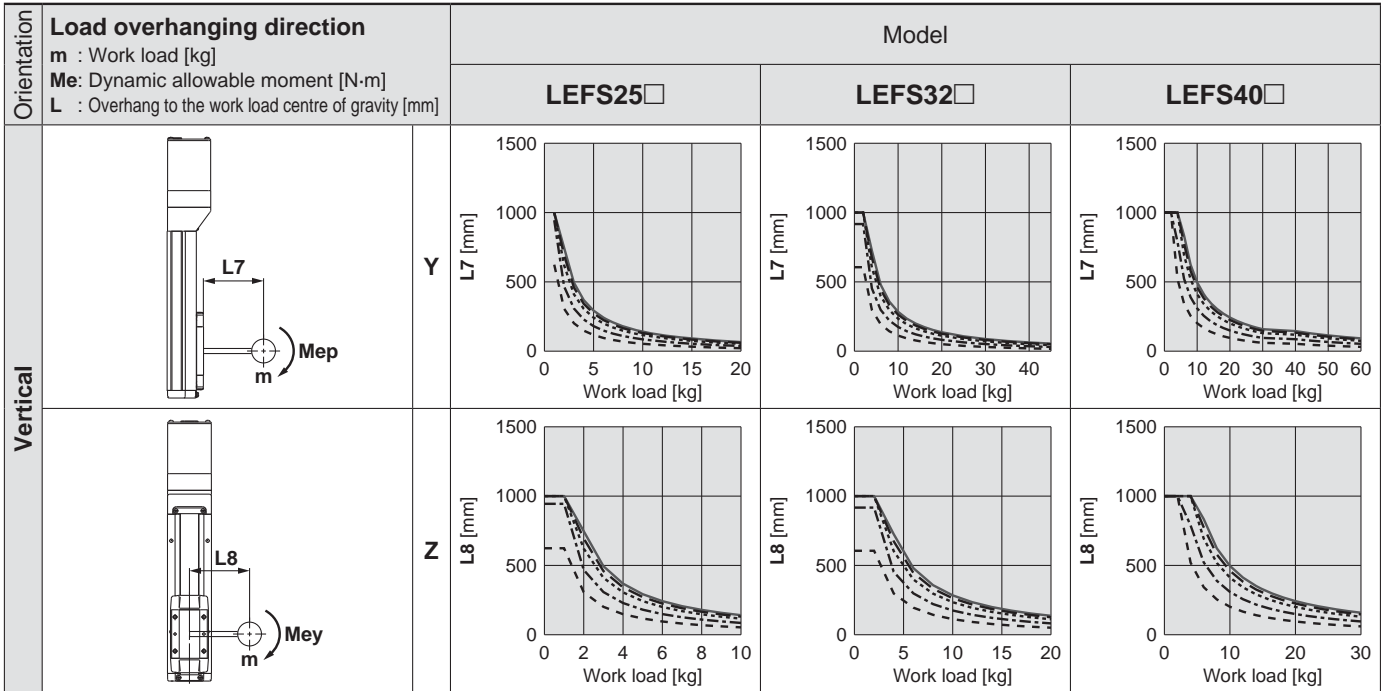

Calculation of Guide Load Factor

1. Determine the operating conditions.

Model: LEFS

Size: 25/32/40

Mounting orientation: Horizontal/Bottom/Wall/Vertical

Acceleration [mm/s²]: a

Work load [kg]: m

Work load centre position [mm]: Xc/Yc/Zc

2. Select the target graph with reference to the model, size and mounting orientation.

3. Based on the acceleration and work load, obtain the overhang [mm]: Lx/Ly/Lz from the graph.

4. Calculate the load factor for each direction.

$$\alpha_x = X_c/L_x, \alpha_y = Y_c/L_y, \alpha_z = Z_c/L_z$$

5. Confirm the total of α_x , α_y and α_z is 1 or less.

$$\alpha_x + \alpha_y + \alpha_z \leq 1$$

When 1 is exceeded, please consider a reduction of acceleration and work load, or a change of the work load centre position or the actuator series.

Mounting orientation

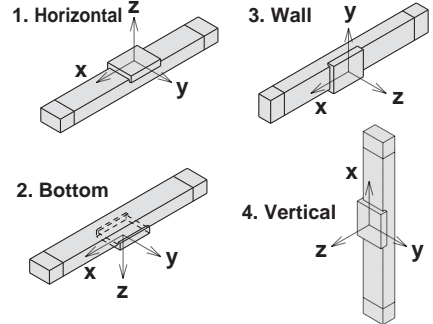

Example

1. Operating conditions

Model: LEFS40

Size: 40

Mounting orientation: Horizontal

Acceleration [mm/s²]: 3000

Work load [kg]: 20

Work load centre position [mm]: Xc = 0, Yc = 50, Zc = 200

2. Refer to the graphs for horizontal mounting of the LEFS40 on page 10.

3. Lx = 250 mm, Ly = 180 mm, Lz = 1000 mm

4. The load factor for each direction can be calculated as follows.

$$\alpha_x = 0/250 = 0$$

$$\alpha_y = 50/180 = 0.27$$

$$\alpha_z = 200/1000 = 0.2$$

5. $\alpha_x + \alpha_y + \alpha_z = 0.47 \leq 1$

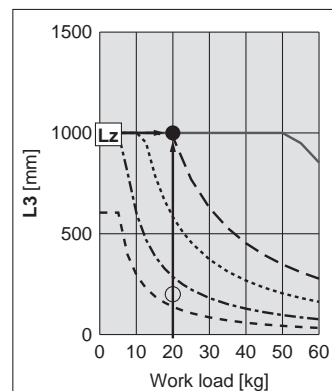
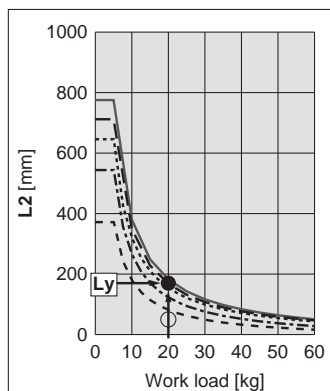
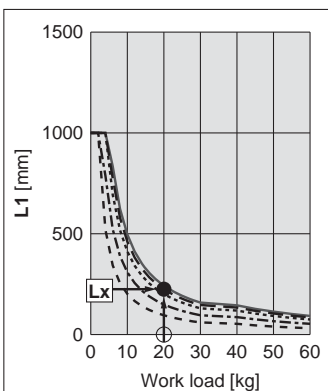
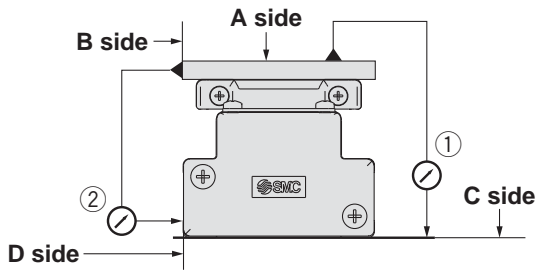

Table Accuracy (Reference Value)



Model	Parallelism of travel [mm] (Every 300 mm)	
	① C side parallelism to A side	② D side parallelism to B side
LEFS25	0.05	0.03
LEFS32	0.05	0.03
LEFS40	0.05	0.03

Note) Parallelism of travel does not include the mounting surface accuracy.

Table Displacement (Reference Value)

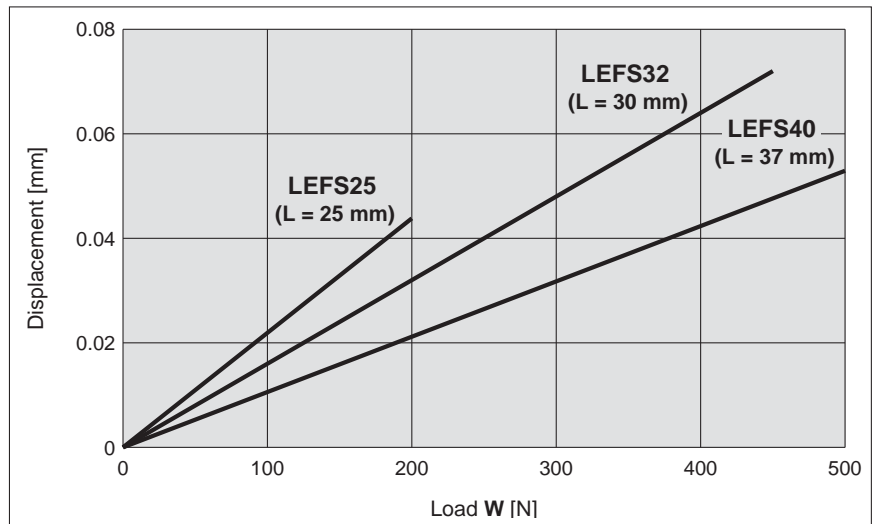
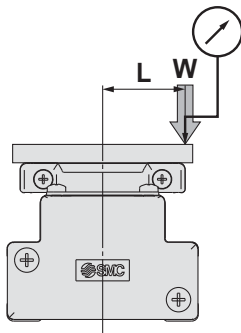

Note 1) This displacement is measured when a 15 mm aluminium plate is mounted and fixed on the table.

Note 2) Check the clearance and play of the guide separately.

Overhang Displacement Due to Table Clearance (Reference Value)

Basic type

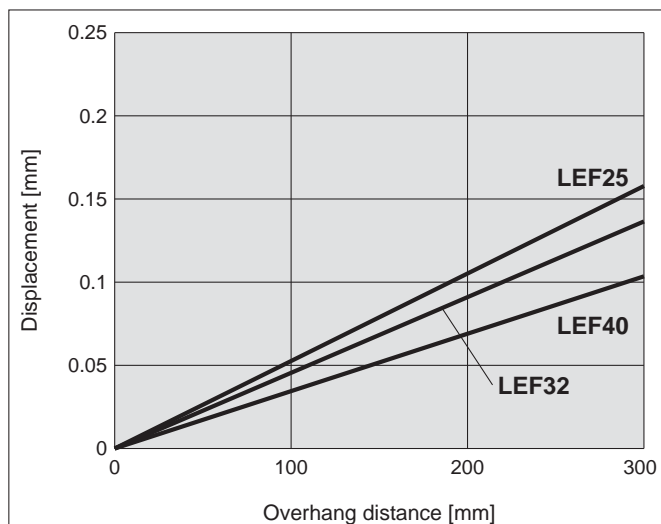

High precision type

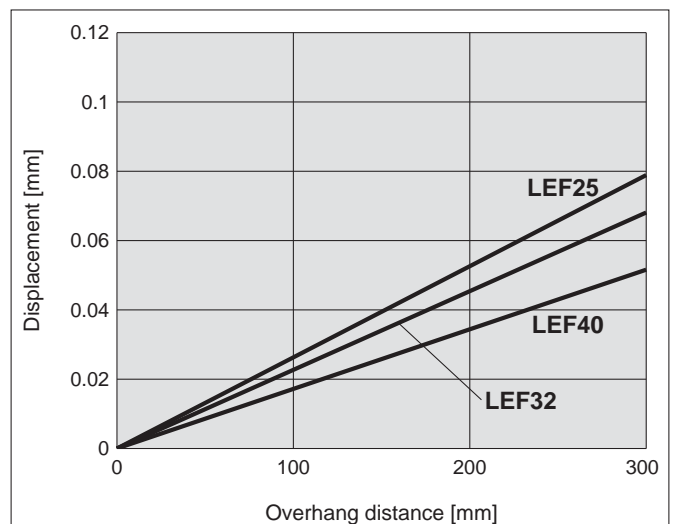

Electric Actuator/Slider Type Ball Screw Drive

Series **LEFS** LEFS25, 32, 40



How to Order

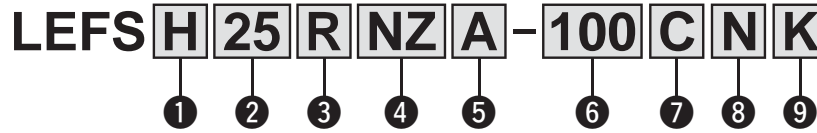

1 Accuracy

—	Basic type
H	High precision type

2 Size

25
32
40

3 Motor mounting position

—	In-line
R	Right side parallel
L	Left side parallel

4 Motor type

Symbol	Type
NZ	Mounting type Z
NY	Mounting type Y
NX	Mounting type X
NW	Mounting type W
NV	Mounting type V
NU	Mounting type U
NT	Mounting type T
NM1	Mounting type M1
NM2	Mounting type M2

5 Lead [mm]

Symbol	LEFS25	LEFS32	LEFS40
H	20	24	30
A	12	16	20
B	6	8	10

6 Stroke [mm]

50	50
to	to
1200	1200

* Refer to the applicable stroke table.

7 Auto Switch mounting bracket

—	None
C	With 1 pc. (included)

* If 2 or more are required, please order them separately. (Part no.: LEF-D-2-1 For details, refer to page 54.)

* Order auto switches separately. (For details, refer to pages 55 and 56.)

9 Positioning pin hole

—	Housing B bottom	
K	Body bottom 2 locations	

* Refer to the body mounting example on page 53 for the mounting method.

8 Grease application (Seal band part)

—	With
N	Without (Roller specification)

Applicable Stroke Table

Model	Stroke (mm)	Stroke (mm)												Stroke (mm)									
		50	100	150	200	250	300	350	400	450	500	550	600	650	700	750	800	850	900	950	1000	1100	1200
LEFS25		●	●	●	●	●	●	●	●	●	●	●	●	●	●	●	—	—	—	—	—	—	—
LEFS32		●	●	●	●	●	●	●	●	●	●	●	●	●	●	●	●	●	●	●	●	—	—
LEFS40		—	—	●	●	●	●	●	●	●	●	●	●	●	●	●	●	●	●	●	●	●	●

* Please consult with SMC for non-standard strokes as they are produced as special orders.

Compatible Motors

Applicable motor model			Size/Motor type																				
Manufacturer	Series	Type	25						32/40														
			NZ Mounting type Z	NY Mounting type Y	NX Mounting type X	NM1 Mounting type M1	NM2 Mounting type M2	NZ Mounting type Z	NY Mounting type Y	NX Mounting type X	NW Mounting type W	NV Mounting type V	NU Mounting type U	NT Mounting type T	NM1 Mounting type M1	NM2 Mounting type M2							
Mitsubishi Electric Corporation	MELSERVO-JN	HF-KN	●	—	—	—	—	—	●	—	—	—	—	—	—	—	—	—	—	—	—	—	—
	MELSERVO-J3	HF-KP	●	—	—	—	—	—	●	—	—	—	—	—	—	—	—	—	—	—	—	—	—
	MELSERVO-J4	HG-KR	●	—	—	—	—	—	●	—	—	—	—	—	—	—	—	—	—	—	—	—	—
YASKAWA Electric Corporation	Σ-V	SGMJV	●	—	—	—	—	—	●	—	—	—	—	—	—	—	—	—	—	—	—	—	
SANYO DENKI CO., LTD.	SANMOTION R	R2	●	—	—	—	—	—	●	—	—	—	—	—	—	—	—	—	—	—	—	—	
OMRON Corporation	Sysmac G5	R88M-K	●	—	—	—	—	—	●	—	—	—	—	—	—	—	—	—	—	—	—	—	
Panasonic Corporation	MINAS-A4	MSMD	—	●	—	—	—	—	—	●	—	—	—	—	—	—	—	—	—	—	—	—	
	MINAS-A5	MSMD/MHMD	—	●	—	—	—	—	—	●	—	—	—	—	—	—	—	—	—	—	—	—	
FANUC CORPORATION	βis	β	●	—	—	—	—	—	●	—	—	—	—	(β1 only)	—	—	●	—	—	—	—	—	
NIDEC SANKYO CORPORATION	S-FLAG	MA/MH/MM	●	—	—	—	—	—	●	—	—	—	—	—	—	—	—	—	—	—	—	—	
KEYENCE CORPORATION	SV	SV-M/SV-B	●	—	—	—	—	—	●	—	—	—	—	—	—	—	—	—	—	—	—	—	
FUJI ELECTRIC CO., LTD.	ALPHA5	GYS/GYB	●	—	—	—	—	—	●	—	—	—	—	—	—	—	—	—	—	—	—	—	
	FALDIC-α	GYS	●	—	—	—	—	—	●	—	—	—	—	—	—	—	—	—	—	—	—	—	
ORIENTAL MOTOR Co., Ltd.	AR/AZ	AR/AZ	—	—	—	—	—	—	—	—	—	—	—	—	—	—	—	—	—	—	—	●*2	
FASTECH Co., Ltd.	Ezi-SERVO	EzM	—	—	—	—	—	—	—	—	—	—	—	—	—	—	—	—	—	—	—	●*2	
Rockwell Automation, Inc. (Allen-Bradley)	MP-/VP-	MP/VP	—	—	—	—	—	—	—	—	—	—	—	—	—	—	—	—	—	—	—	—	
	TL	TLY-A	●	—	—	—	—	—	—	—	—	—	—	—	—	—	—	—	—	—	—	●	
Beckhoff Automation GmbH	AM	AM30	●	—	—	—	—	—	—	—	—	—	—	—	—	—	—	—	—	—	—	—	
	AM	AM31	●	—	—	—	—	—	—	—	—	—	—	—	—	—	—	—	—	—	—	—	
	AM	AM80/AM81	●	—	—	—	—	—	—	—	—	—	—	—	—	—	—	—	—	—	—	—	
Siemens AG	1FK7	1FK7	—	—	—	●	—	—	—	—	—	—	—	—	—	—	—	—	—	—	—	—	
	1FK2	1FK2	●	—	—	—	—	—	●	—	—	—	—	—	—	—	—	—	—	—	—	—	
Delta Electronics, Inc.	ASDA-A2	ECMA	●	—	—	—	—	—	●	—	—	—	—	—	—	—	—	—	—	—	—	—	

*1 Motor mounting position: In-line only

*2 Only size 32 is available when the motor mounting position is right (or left) side parallel.

Specifications Note 2)

• The values given below are within the actuator body specifications range, with a standard motor mounted and should not be exceeded.

Model		LEFS25			LEFS32			LEFS40			
Stroke [mm] <small>Note 1)</small>		50 to 800			50 to 1000			150 to 1200			
Work load [kg]	Horizontal	10	20	20	30	40	45	30	50	60	
	Vertical	4	8	15	5	10	20	7	15	30	
Speed [mm/s]	Stroke range	Up to 400	1500	900	450	1500	1000	500	1500	1000	500
		401 to 500	1200	720	360	1500	1000	500	1500	1000	500
		501 to 600	900	540	270	1200	800	400	1500	1000	500
		601 to 700	700	420	210	930	620	310	1410	940	470
		701 to 800	550	330	160	750	500	250	1140	760	380
		801 to 900	—	—	—	610	410	200	930	620	310
		901 to 1000	—	—	—	510	340	170	780	520	260
		1001 to 1100	—	—	—	—	—	—	500	440	220
	1101 to 1200	—	—	—	—	—	—	500	380	190	
Pushing return to origin speed [mm/s]		30 or less									
Positioning repeatability [mm]	Basic type	±0.02									
	High precision type	±0.01									
Lost motion <small>Note 3)</small> [mm]	Basic type	0.1 or less									
	High precision type	0.05 or less									
Ball screw specifications	Thread size [mm]	Ø 10			Ø 12			Ø 15			
	Lead [mm]	20	12	6	24	16	8	30	20	10	
	Shaft length [mm]	Stroke + 150			Stroke + 185			Stroke + 235			
Max. acceleration/deceleration [mm/s ²]		20000 <small>Note 4)</small>									
Impact/Vibration resistance [m/s ²] <small>Note 6)</small>		50/20									
Actuation type		Ball screw (LEFS□), Ball screw + Belt (LEFS□ ^R)									
Guide type		Linear guide									
Operating temperature range [°C]		5 to 40									
Operating humidity range [%RH]		90 or less (No condensation)									
Other specifications <small>Note 5)</small>	Actuation unit weight [kg]	0.2			0.3			0.55			
	Other inertia [kg·cm ²]	0.02 (LEFS25) 0.02 (LEFS25 ^R)			0.08 (LEFS32) 0.06 (LEFS32 ^R)			0.08 (LEFS40) 0.17 (LEFS40 ^R)			
	Coefficient of friction	0.05									
	Mechanical efficiency	0.8									
Reference motor specifications	Motor shape	□40			□60						
	Motor type	AC servo motor (100 V/200 V)									
	Rated output capacity [W]	100			200			400			
	Rated torque [N·m]	0.32			0.64			1.3			
	Rated rotation [rpm]	3000									

Note 1) Please consult with SMC for non-standard strokes as they are produced as special orders.

Note 2) Do not allow collisions at either end of the table at a speed exceeding "pushing return to origin speed."

Additionally, when running the positioning operation, do not set within 2 mm of either end.

Note 3) A reference value for correcting an error in reciprocal operation.

Note 4) Maximum acceleration/deceleration will vary according to the work load.

Refer to the "Work Load–Acceleration/Deceleration Graph (Guide)" for ball screw drive on pages 7 to 9.

Note 5) The values are a guide only and should be used to select a motor capacity.

Note 6) Impact resistance: No malfunction occurred when the actuator was tested with a drop tester in both an axial direction and a perpendicular direction to the lead screw. (Test was performed with the actuator in the initial state.)

Vibration resistance: No malfunction occurred in a test ranging between 45 to 2000 Hz. Test was performed in both an axial direction and a perpendicular direction to the lead screw. (Test was performed with the actuator in the initial state.)

Weight

Model	LEFS25															
Stroke [mm]	50	100	150	200	250	300	350	400	450	500	550	600	650	700	750	800
Weight [kg]	1.50	1.70	1.80	2.00	2.10	2.25	2.40	2.55	2.70	2.80	2.90	3.10	3.35	3.50	3.65	3.80

Model	LEFS32																			
Stroke [mm]	50	100	150	200	250	300	350	400	450	500	550	600	650	700	750	800	850	900	950	1000
Weight [kg]	2.40	2.60	2.80	3.00	3.20	3.40	3.60	3.80	4.00	4.20	4.40	4.60	4.80	5.00	5.20	5.40	5.60	5.80	6.00	6.20

Model	LEFS40																			
Stroke [mm]	150	200	250	300	350	400	450	500	550	600	650	700	750	800	850	900	950	1000	1100	1200
Weight [kg]	4.60	4.80	5.20	5.35	5.70	5.95	6.30	6.50	6.80	6.95	7.40	7.60	8.00	8.15	8.50	8.75	9.10	9.30	9.76	10.32

Model Selection
LEFS
LEFB
LEJS
LEY
LEYG
Motor Mounting

Series LEFS

Motorless Type

Refer to the "Motor Mounting" on page 29 for details of motor mounting and parts included.

Dimensions: Ball Screw Drive

LEFS25

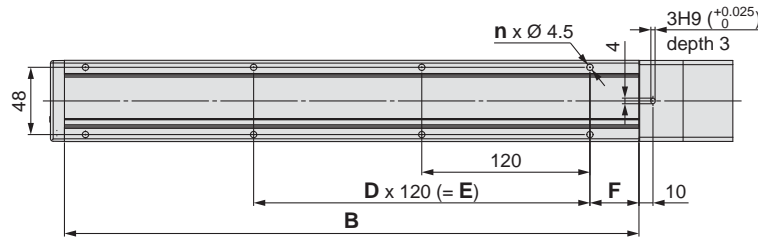

Motor type: NZ, NY, NX

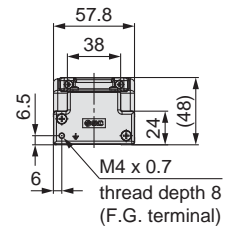
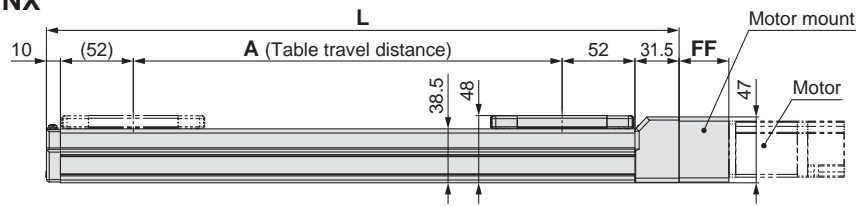
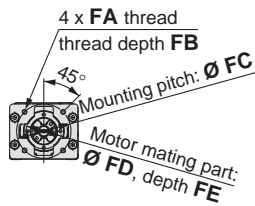

Motor type: NM1, NM2

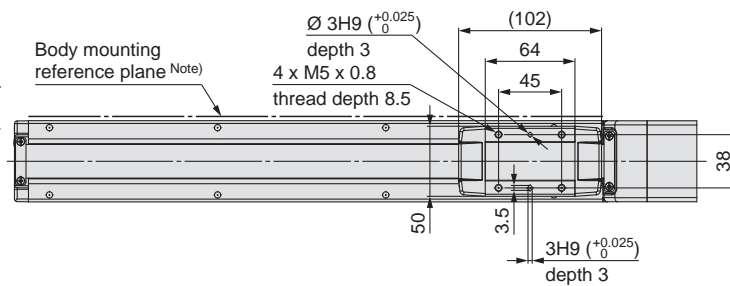
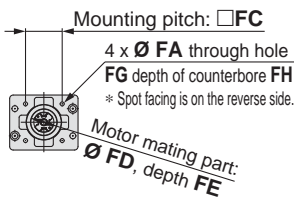

Note) When mounting the actuator using the body mounting reference plane, set the height of the mating surface or positioning pins to 3 mm minimum. (Recommended height 5 mm)

Dimensions

Stroke	L	A	B	n	D	E	F
50	201.5	56	160	4	—	—	20
100	251.5	106	210	4	—	—	35
150	301.5	156	260	4	—	—	35
200	351.5	206	310	6	2	240	35
250	401.5	256	360	6	2	240	35
300	451.5	306	410	8	3	360	35
350	501.5	356	460	8	3	360	35
400	551.5	406	510	8	3	360	35
450	601.5	456	560	10	4	480	35
500	651.5	506	610	10	4	480	35
550	701.5	556	660	12	5	600	35
600	751.5	606	710	12	5	600	35
650	801.5	656	760	12	5	600	35
700	851.5	706	810	14	6	720	35
750	901.5	756	860	14	6	720	35
800	951.5	806	910	16	7	840	35

Motor Mounting Dimensions

Motor type	FA	FB	FC	FD	FE	FF	FG	FH
NZ/NX	M4 x 0.7	8	46	30	3.5	35.5	—	—
NY	M3 x 0.5	8	45	30	3.5	35.5	—	—
NM1	3.4	—	31	22*	2.5*	24	6.5	13.5
NM2	3.4	—	31	22*	2.5*	33.1	6.5	22.6

* Dimensions after mounting a ring spacer (Refer to page 29.)

Refer to the "Motor Mounting" on page 29 for details about motor mounting and included parts.

Dimensions: Ball Screw Drive

LEFS25

Positioning pin hole ^{Note)} (Option): Body bottom

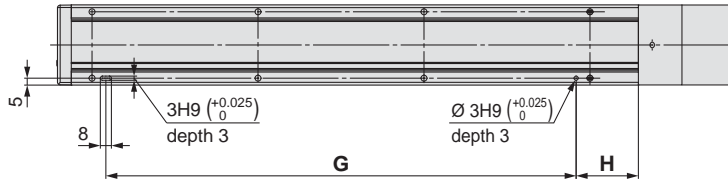

Note) When using the body bottom positioning pin holes, do not simultaneously use the housing B bottom pin hole.

With auto switch (Option)

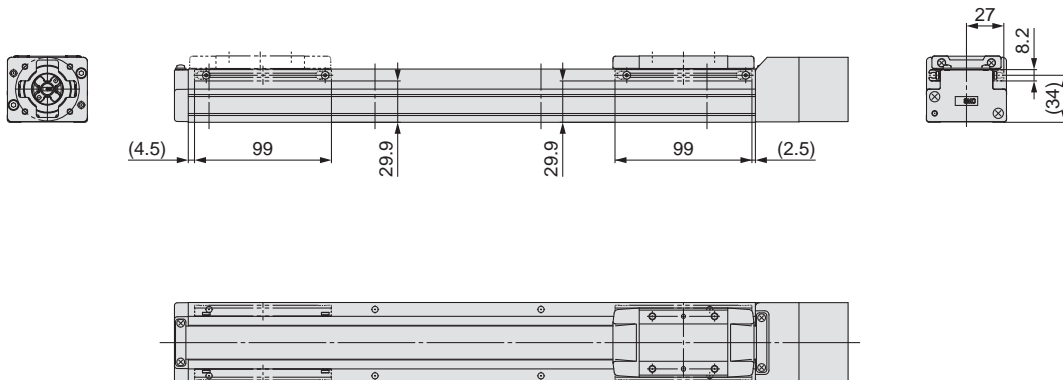

Dimensions [mm]

Stroke	G	H
50	100	30
100	100	45
150	100	45
200	220	45
250	220	45
300	340	45
350	340	45
400	340	45
450	460	45
500	460	45
550	580	45
600	580	45
650	580	45
700	700	45
750	700	45
800	820	45

Series LEFS

Motorless Type

Refer to the "Motor Mounting" on page 29 for details of motor mounting and parts included.

Dimensions: Ball Screw Drive

LEFS32

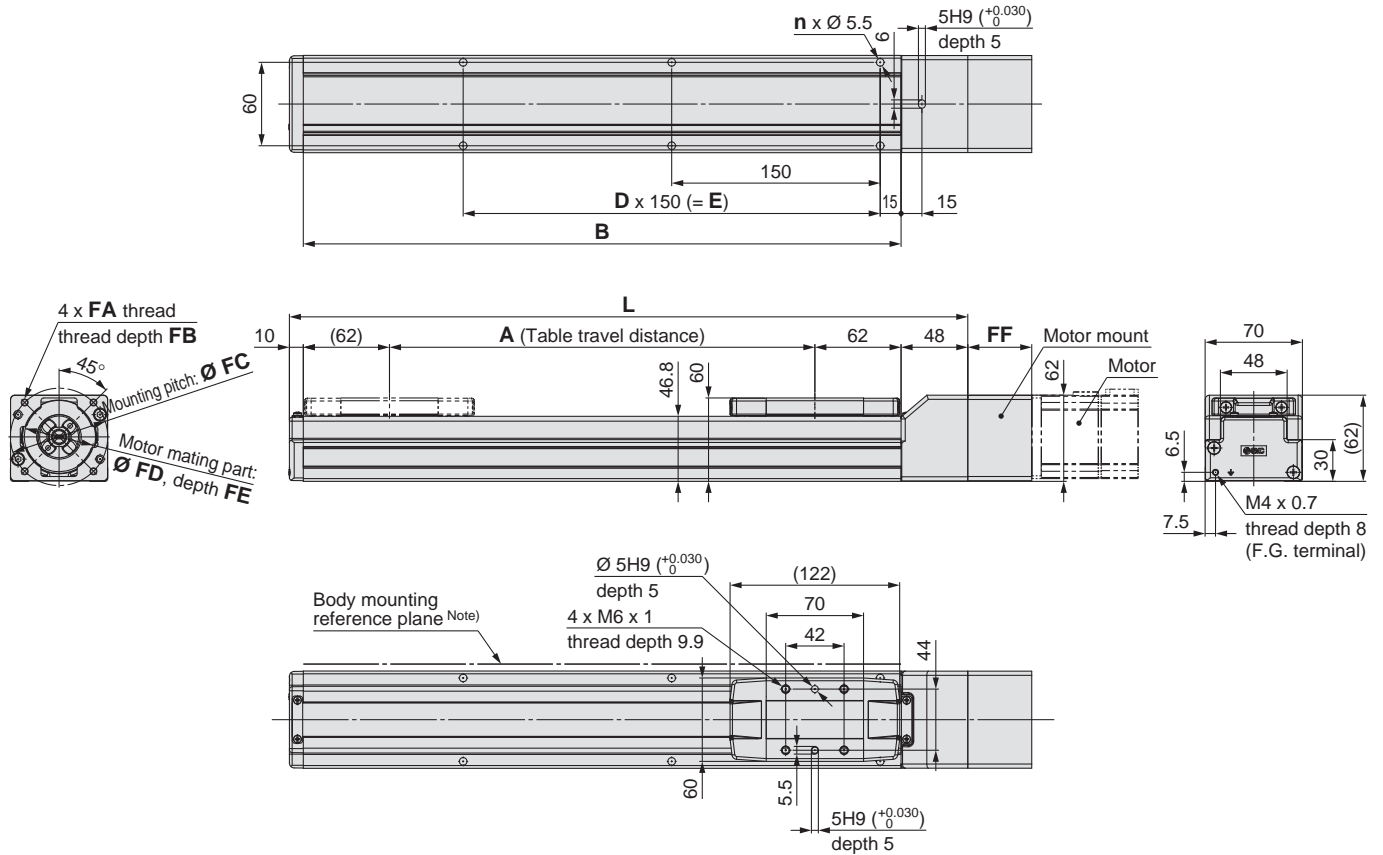

Note) When mounting the actuator using the body mounting reference plane, set the height of the mating surface or positioning pins to 3 mm minimum. (Recommended height 5 mm)

Dimensions

[mm]

Stroke	L	A	B	n	D	E
50	238	56	180	4	—	—
100	288	106	230	4	—	—
150	338	156	280	4	—	—
200	388	206	330	6	2	300
250	438	256	380	6	2	300
300	488	306	430	6	2	300
350	538	356	480	8	3	450
400	588	406	530	8	3	450
450	638	456	580	8	3	450
500	688	506	630	10	4	600
550	738	556	680	10	4	600
600	788	606	730	10	4	600
650	838	656	780	12	5	750
700	888	706	830	12	5	750
750	938	756	880	12	5	750
800	988	806	930	14	6	900
850	1038	856	980	14	6	900
900	1088	906	1030	14	6	900
950	1138	956	1080	16	7	1050
1000	1188	1006	1130	16	7	1050

Motor Mounting Dimensions

[mm]

Motor type	FA	FB	FC	FD	FE	FF
NZ/NT	M5 x 0.8	9	70	50	5	46
NY	M4 x 0.7	8	70	50	5	46
NX	M5 x 0.8	9	63	40*	4.5*	49.7
NW/NU	M5 x 0.8	9	70	50	5	47.5
NV	M4 x 0.7	8	63	40*	4.5*	49.7
NM1	M4 x 0.7	8	□47.14	38.1*	4.5*	21
NM2	M4 x 0.7	8	□50	36*	4.5*	40.1

* Dimensions after mounting a ring spacer (Refer to page 29.)

Refer to the "Motor Mounting" on page 29 for details about motor mounting and included parts.

Dimensions: Ball Screw Drive

LEFS32

Positioning pin hole ^{Note)} (Option): Body bottom

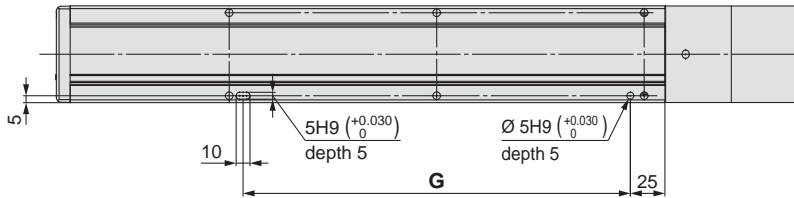

Note) When using the body bottom positioning pin holes, do not simultaneously use the housing B bottom pin hole.

With auto switch (Option)

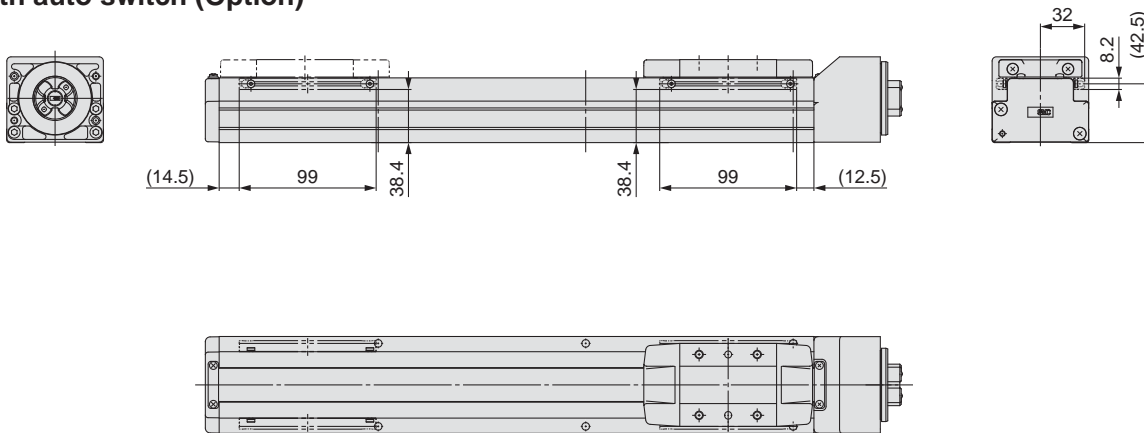

Dimensions [mm]

Stroke	G
50	130
100	130
150	130
200	280
250	280
300	280
350	430
400	430
450	430
500	580
550	580
600	580
650	730
700	730
750	730
800	880
850	880
900	880
950	1030
1000	1030

Series LEFS

Motorless Type

Refer to the "Motor Mounting" on page 29 for details of motor mounting and parts included.

Dimensions: Ball Screw Drive

LEFS40

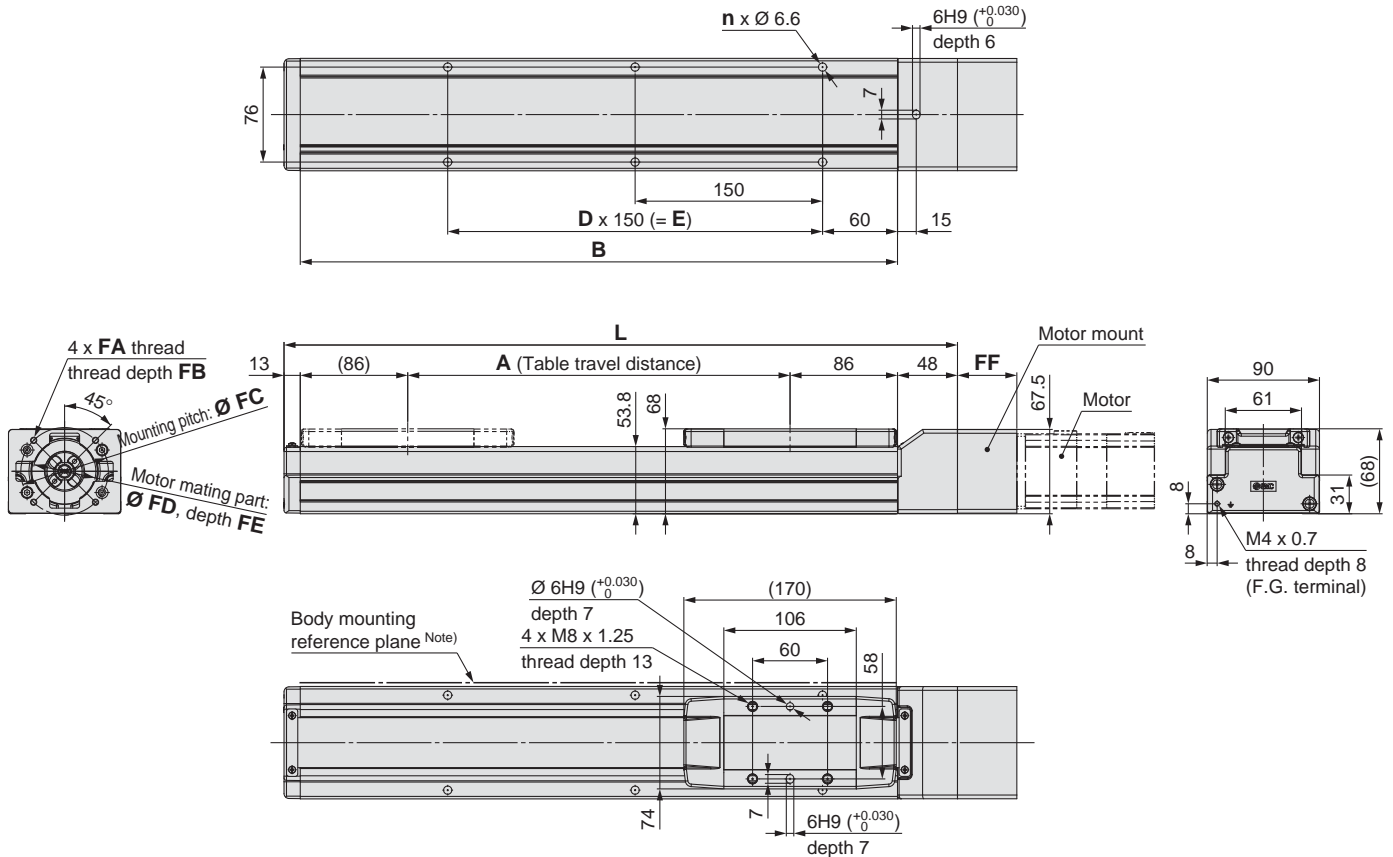

Note) When mounting the actuator using the body mounting reference plane, set the height of the mating surface or positioning pins to 3 mm minimum. (Recommended height 5 mm)

Dimensions

[mm]

Stroke	L	A	B	n	D	E
150	389	156	328	4	—	150
200	439	206	378	6	2	300
250	489	256	428	6	2	300
300	539	306	478	6	2	300
350	589	356	528	8	3	450
400	639	406	578	8	3	450
450	689	456	628	8	3	450
500	739	506	678	10	4	600
550	789	556	728	10	4	600
600	839	606	778	10	4	600
650	889	656	828	12	5	750
700	939	706	878	12	5	750
750	989	756	928	12	5	750
800	1039	806	978	14	6	900
850	1089	856	1028	14	6	900
900	1139	906	1078	14	6	900
950	1189	956	1128	16	7	1050
1000	1239	1006	1178	16	7	1050
1100	1339	1106	1278	18	8	1200
1200	1439	1206	1378	18	8	1200

Motor Mounting Dimensions

[mm]

Motor type	FA	FB	FC	FD	FE	FF
NZ/NT	M5 x 0.8	9	70	50	5	47.5
NY	M4 x 0.7	8	70	50	5	47.5
NX	M5 x 0.8	9	63	40*	4.5*	51
NW/NU	M5 x 0.8	9	70	50	5	48.8
NV	M4 x 0.7	8	63	40*	4.5*	51
NM1	M4 x 0.7	8	□47.14	38.1*	4.5*	22
NM2	M4 x 0.7	8	□50	36*	4.5*	41.4

* Dimensions after mounting a ring spacer (Refer to page 29.)

Refer to the "Motor Mounting" on page 29 for details about motor mounting and included parts.

Dimensions: Ball Screw Drive

LEFS40

Positioning pin hole ^{Note)} (Option): Body bottom

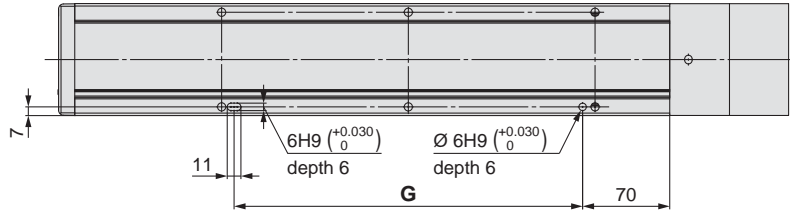

Note) When using the body bottom positioning pin holes, do not simultaneously use the housing B bottom pin hole.

With auto switch (Option)

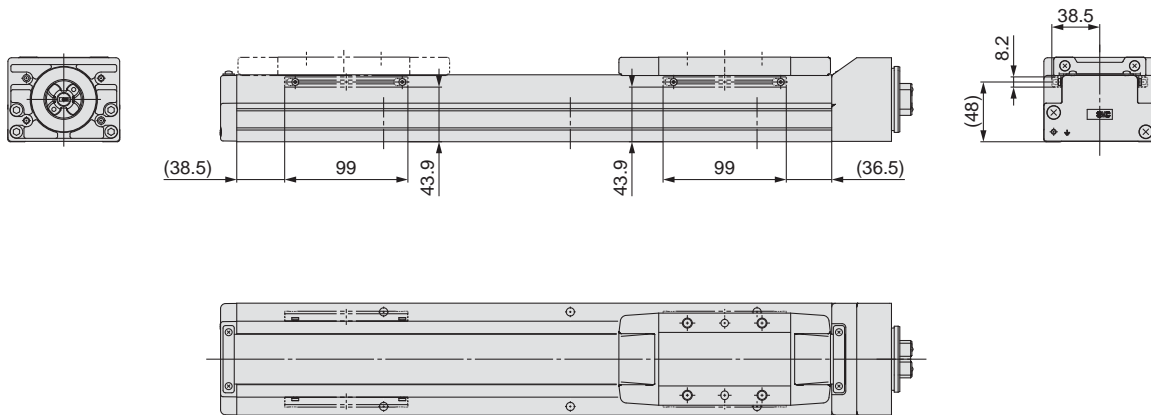

Dimensions [mm]

Stroke	G
150	130
200	280
250	280
300	280
350	430
400	430
450	430
500	580
550	580
600	580
650	730
700	730
750	730
800	880
850	880
900	880
950	1030
1000	1030
1100	1180
1200	1180

Series LEFS

Motorless Type

Refer to the "Motor Mounting" on page 30 for details of motor mounting and parts included.

Dimensions: Ball Screw Drive

LEFS25R

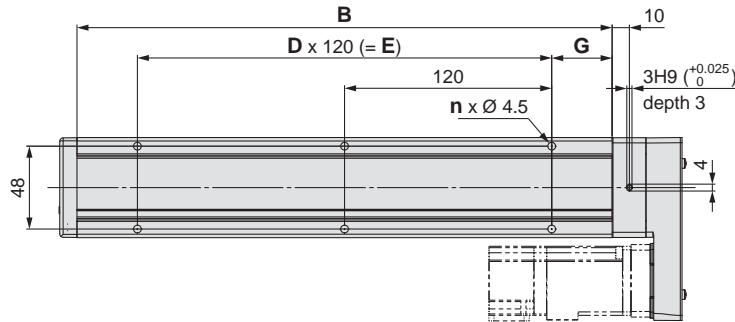

Motor type: NZ, NY, NX

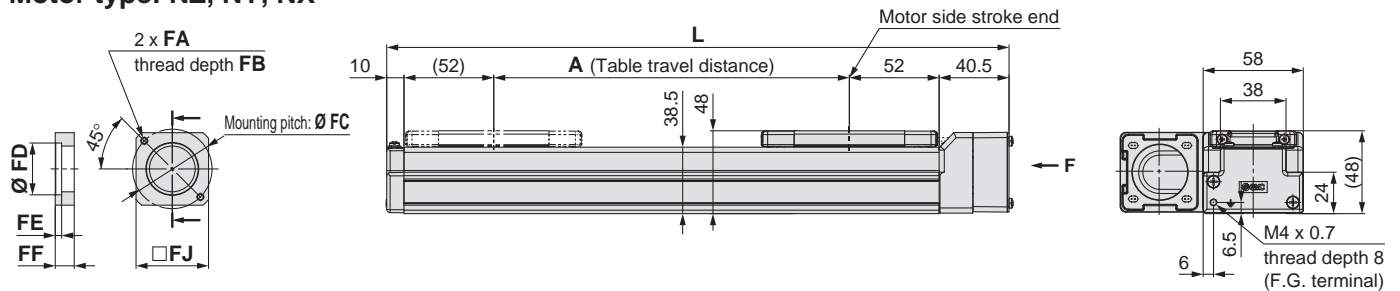

Motor type: NM1, NM2

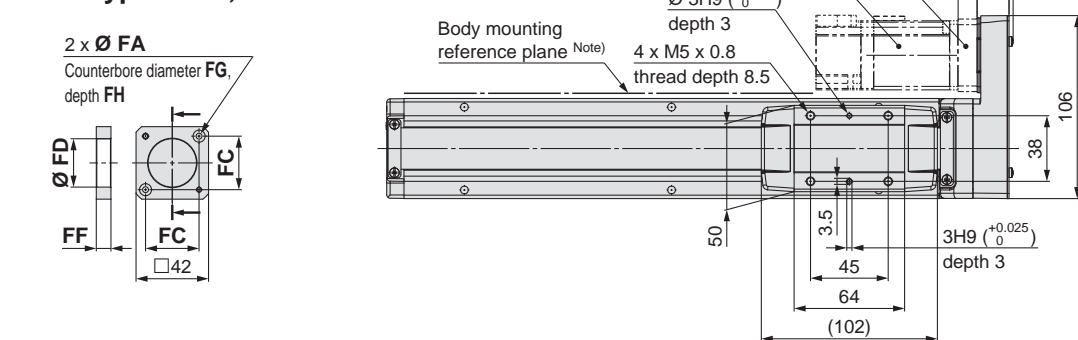

Note) When mounting the actuator using the body mounting reference plane, set the height of the mating surface or positioning pins to 3 mm minimum. (Recommended height 5 mm)

Dimensions

Model	L	A	B	n	D	E	G
LEFS25□□□-50	210.5	56	160	4	—	—	20
LEFS25□□□-100	260.5	106	210	4	—	—	35
LEFS25□□□-150	310.5	156	260	4	—	—	35
LEFS25□□□-200	360.5	206	310	6	2	240	35
LEFS25□□□-250	410.5	256	360	6	2	240	35
LEFS25□□□-300	460.5	306	410	8	3	360	35
LEFS25□□□-350	510.5	356	460	8	3	360	35
LEFS25□□□-400	560.5	406	510	8	3	360	35
LEFS25□□□-450	610.5	456	560	10	4	480	35
LEFS25□□□-500	660.5	506	610	10	4	480	35
LEFS25□□□-550	710.5	556	660	12	5	600	35
LEFS25□□□-600	760.5	606	710	12	5	600	35
LEFS25□□□-650	810.5	656	760	12	5	600	35
LEFS25□□□-700	860.5	706	810	14	6	720	35
LEFS25□□□-750	910.5	756	860	14	6	720	35
LEFS25□□□-800	960.5	806	910	16	7	840	35

Motor Mounting Dimensions

Motor type	FA	FB	FC	FD	FE	FF	FG	FH	FJ
NZ	M4 x 0.7	7.5	46	30	3.7	11	—	—	42
NY	M3 x 0.5	5.5	45	30	5	11	—	—	38
NX	M4 x 0.7	7	46	30	3.7	8	—	—	42
NM1/NM2	Ø 3.4	—	31	28	—	8.5	7	3.5	—

Refer to the "Motor Mounting" on page 30 for details about motor mounting and included parts.

Dimensions: Ball Screw Drive

LEFS25R

Positioning pin hole ^{Note)} (Option): Body bottom

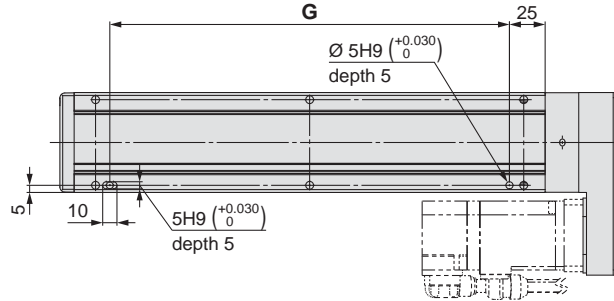

Note) When using the body bottom positioning pin holes, do not simultaneously use the housing B bottom pin hole.

With auto switch (Option)

LEFS25R

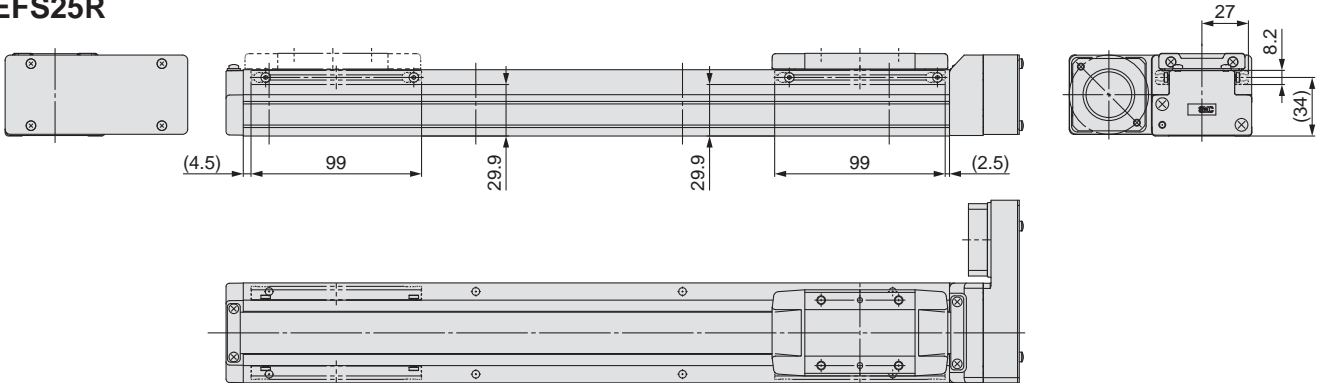

LEFS25L

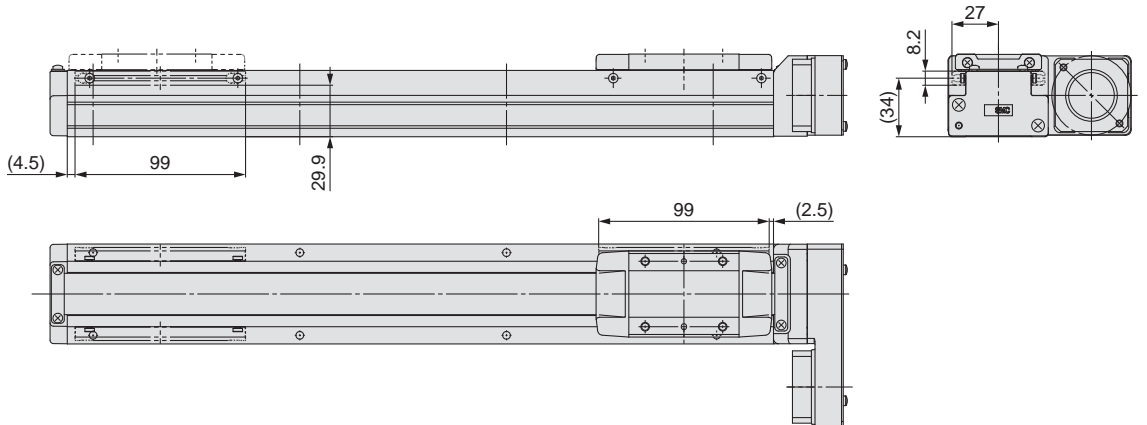

Dimensions [mm]

Stroke	H
50	130
100	130
150	130
200	280
250	280
300	280
350	430
400	430
450	430
500	580
550	580
600	580
650	730
700	730
750	730
800	880

Series LEFS

Motorless Type

Refer to the "Motor Mounting" on page 30 for details of motor mounting and parts included.

Dimensions: Ball Screw Drive

LEFS32R

Motor type: NM1, NM2

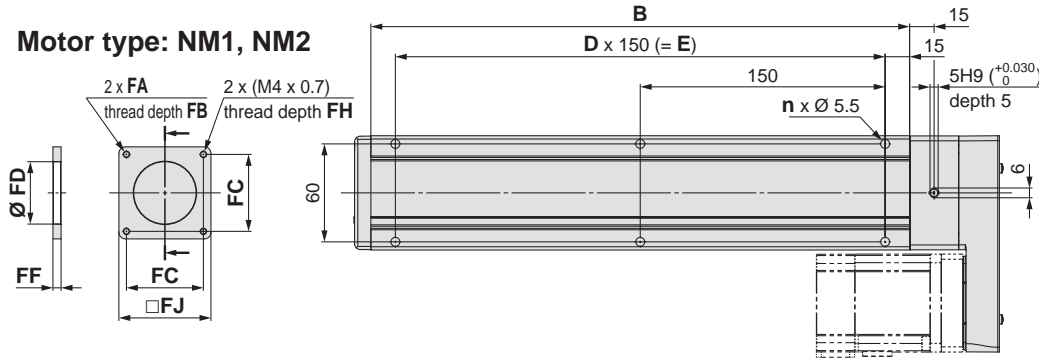

Motor type: NZ, NY, NW, NU, NT

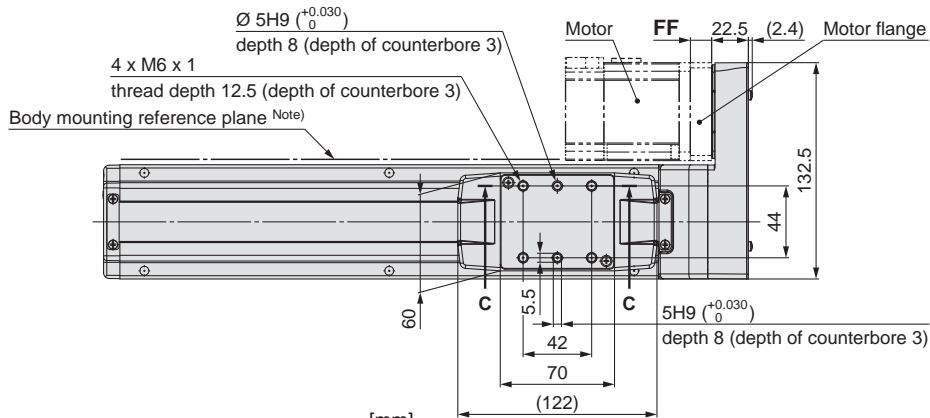
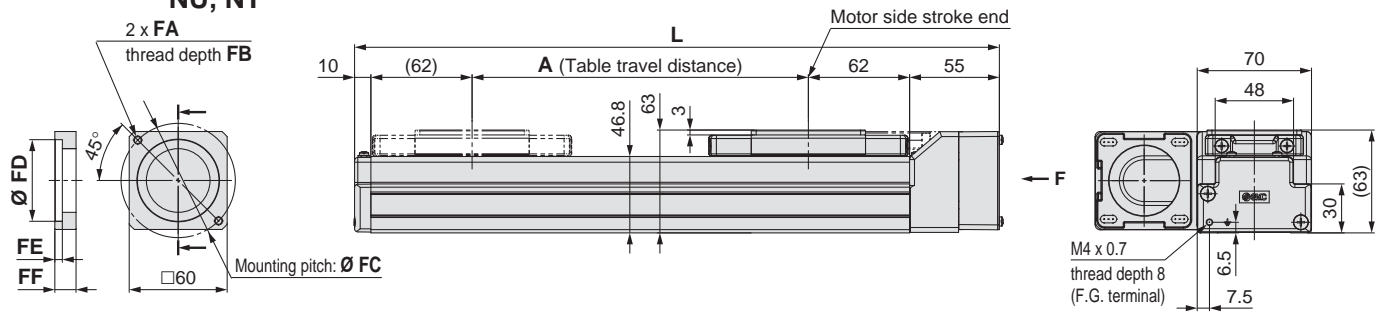

Dimensions

Model	L	A	B	n	D	E
LEFS32□□□-50	245	56	180	4	—	—
LEFS32□□□-100	295	106	230	4	—	—
LEFS32□□□-150	345	156	280	4	—	—
LEFS32□□□-200	395	206	330	6	2	300
LEFS32□□□-250	445	256	380	6	2	300
LEFS32□□□-300	495	306	430	6	2	300
LEFS32□□□-350	545	356	480	8	3	450
LEFS32□□□-400	595	406	530	8	3	450
LEFS32□□□-450	645	456	580	8	3	450
LEFS32□□□-500	695	506	630	10	4	600
LEFS32□□□-550	745	556	680	10	4	600
LEFS32□□□-600	795	606	730	10	4	600
LEFS32□□□-650	845	656	780	12	5	750
LEFS32□□□-700	895	706	830	12	5	750
LEFS32□□□-750	945	756	880	12	5	750
LEFS32□□□-800	995	806	930	14	6	900
LEFS32□□□-850	1045	856	980	14	6	900
LEFS32□□□-900	1095	906	1030	14	6	900
LEFS32□□□-950	1145	956	1080	16	7	1050
LEFS32□□□-1000	1195	1006	1130	16	7	1050

Note) When mounting the actuator using the body mounting reference plane, set the height of the mating surface or positioning pins to 3 mm minimum. (Recommended height 5 mm)

Motor Mounting Dimensions

Motor type	FA	FB	FC	FD	FE	FF	FJ	FH
NZ/NW	M5 x 0.8	8.5	70	50	4.6	13	—	—
NY	M4 x 0.7	8	70	50	4.6	13	—	—
NU	M5 x 0.8	8.5	70	50	4.6	10.6	—	—
NT	M5 x 0.8	8.5	70	50	4.6	17	—	—
NM1	M4 x 0.7	5	47.14	38.2	—	5	56.4	5
NM2	M4 x 0.7	8	50	38.2	—	11.5	60	7

Refer to the "Motor Mounting" on page 30 for details about motor mounting and included parts.

Dimensions: Ball Screw Drive

LEFS32R

Positioning pin hole ^{Note)} (Option): Body bottom

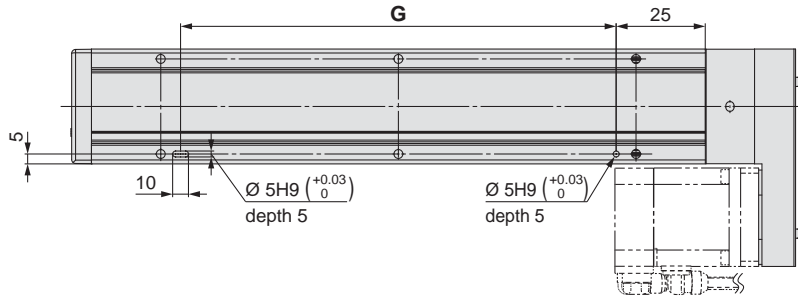

Note) When using the body bottom positioning pin holes, do not simultaneously use the housing B bottom pin hole.

With auto switch (Option)

LEFS32R

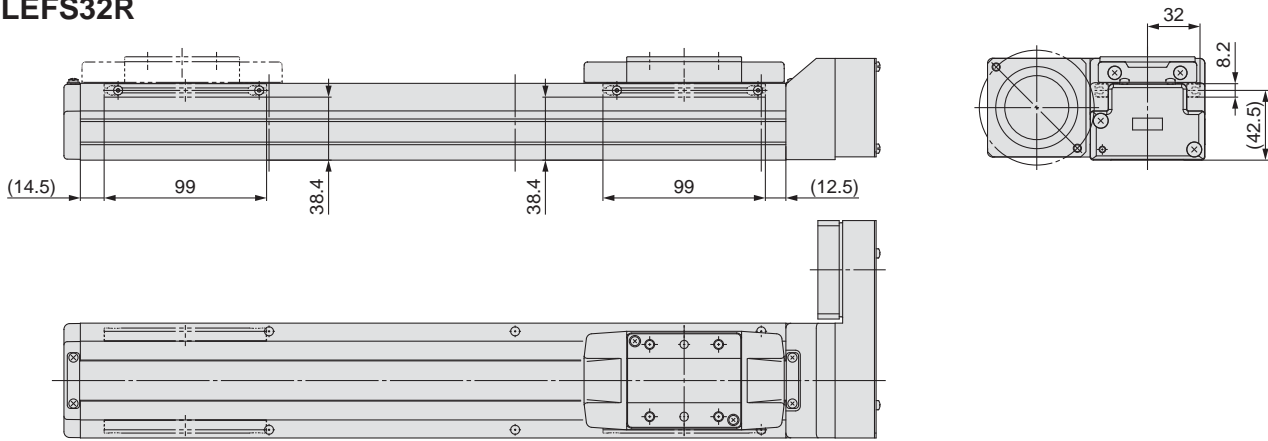

LEFS32L

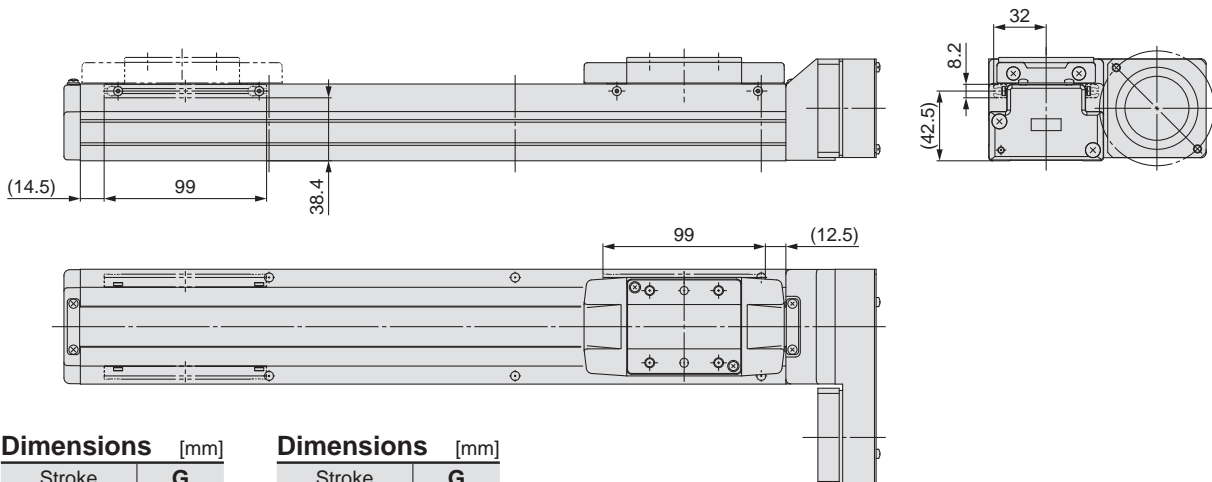

Dimensions [mm]

Stroke	G
50	130
100	130
150	130
200	280
250	280
300	280
350	430
400	430
450	430
500	580

Dimensions [mm]

Stroke	G
550	580
600	580
650	730
700	730
750	730
800	880
850	880
900	880
950	1030
1000	1030

Series LEFS

Motorless Type

Refer to the "Motor Mounting" on page 30 for details of motor mounting and parts included.

Dimensions: Ball Screw Drive

LEFS40R

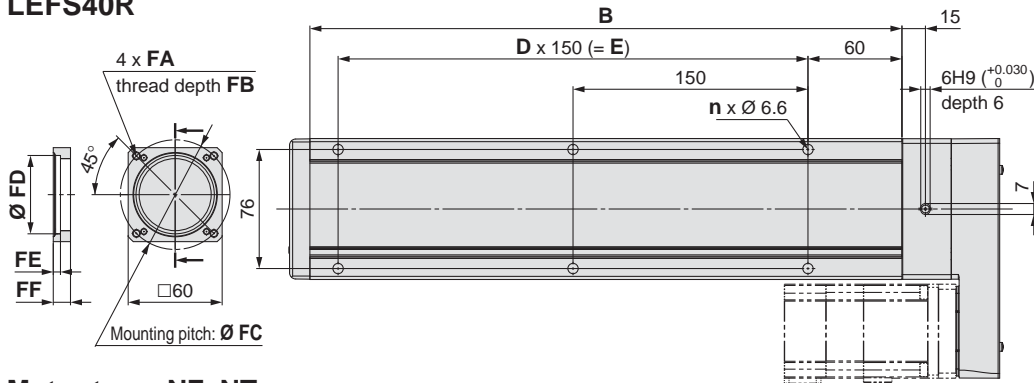

Motor type: **NZ, NT, NY, NW**

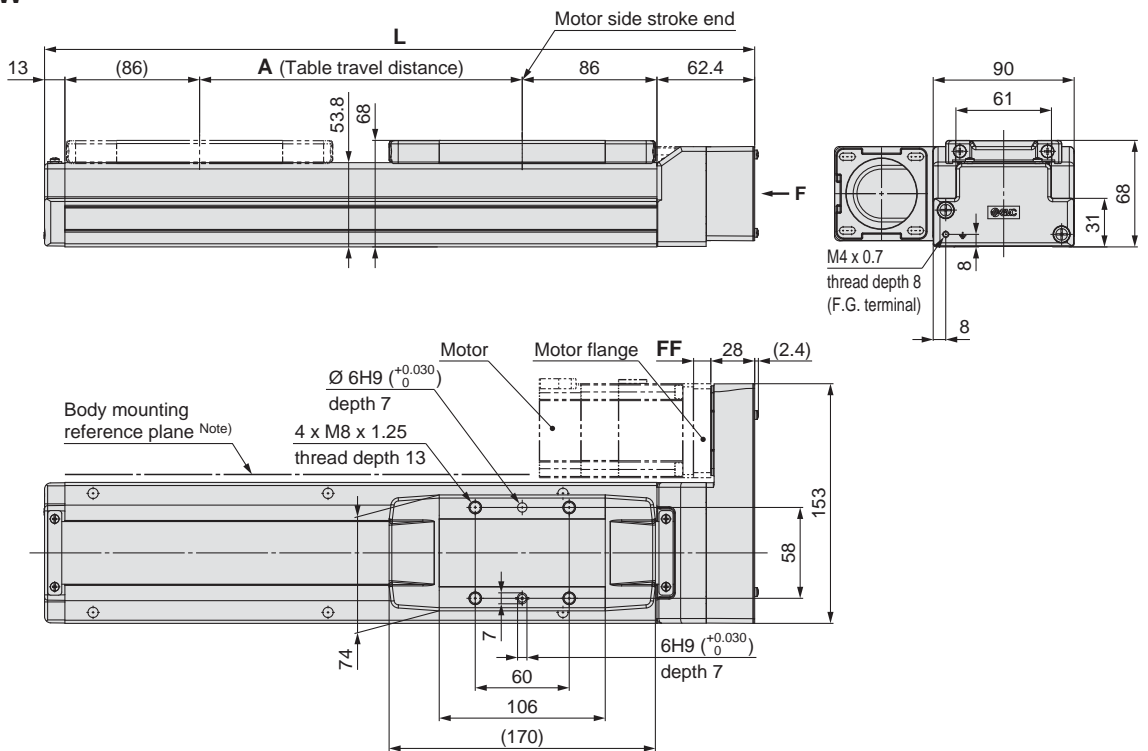

Dimensions

Model	L	A	B	n	D	E
LEFS40□□□-150	403.4	156	328	4	—	150
LEFS40□□□-200	453.4	206	378	6	2	300
LEFS40□□□-250	503.4	256	428	6	2	300
LEFS40□□□-300	553.4	306	478	6	2	300
LEFS40□□□-350	603.4	356	528	8	3	450
LEFS40□□□-400	653.4	406	578	8	3	450
LEFS40□□□-450	703.4	456	628	8	3	450
LEFS40□□□-500	753.4	506	678	10	4	600
LEFS40□□□-550	803.4	556	728	10	4	600
LEFS40□□□-600	853.4	606	778	10	4	600
LEFS40□□□-650	903.4	656	828	12	5	750
LEFS40□□□-700	953.4	706	878	12	5	750
LEFS40□□□-750	1003.4	756	928	12	5	750
LEFS40□□□-800	1053.4	806	978	14	6	900
LEFS40□□□-850	1103.4	856	1028	14	6	900
LEFS40□□□-900	1153.4	906	1078	14	6	900
LEFS40□□□-950	1203.4	956	1128	16	7	1050
LEFS40□□□-1000	1253.4	1006	1178	16	7	1050
LEFS40□□□-1100	1353.4	1106	1278	18	8	1200
LEFS40□□□-1200	1453.4	1206	1378	18	8	1200

Note) When mounting the actuator using the body mounting reference plane, set the height of the mating surface or positioning pins to 3 mm minimum. (Recommended height 5 mm)

Motor Mounting Dimensions

Motor type	FA	FB	FC	FD	FE	FF
NZ/NW	M5 x 0.8	8.5	70	50	4.6	11
NY	M4 x 0.7	8	70	50	4.6	11
NT	M5 x 0.8	8.5	70	50	4.6	14.5

Refer to the "Motor Mounting" on page 30 for details about motor mounting and included parts.

Dimensions: Ball Screw Drive

LEFS40R

Positioning pin hole ^{Note)} (Option): Body bottom

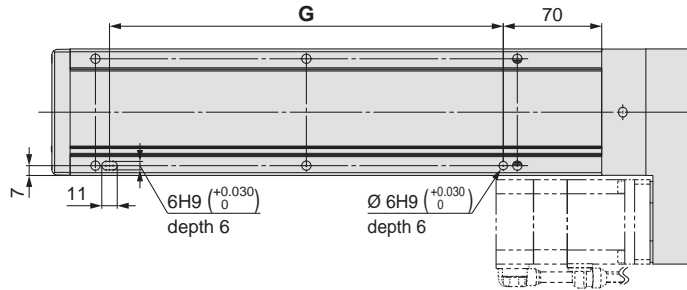

Note) When using the body bottom positioning pin holes, do not simultaneously use the housing B bottom pin hole.

With auto switch (Option)

LEFS40R

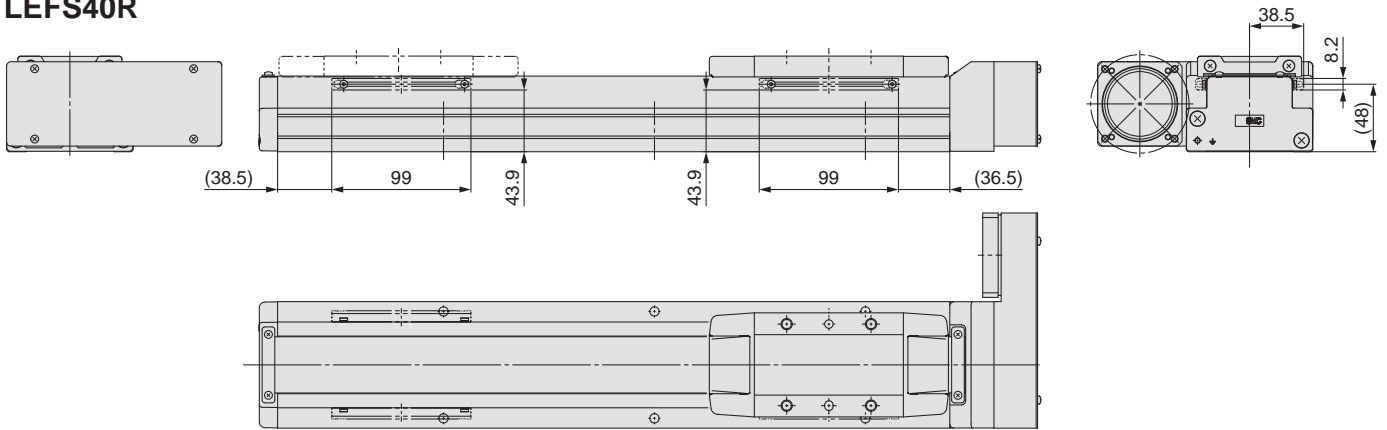

LEFS40L

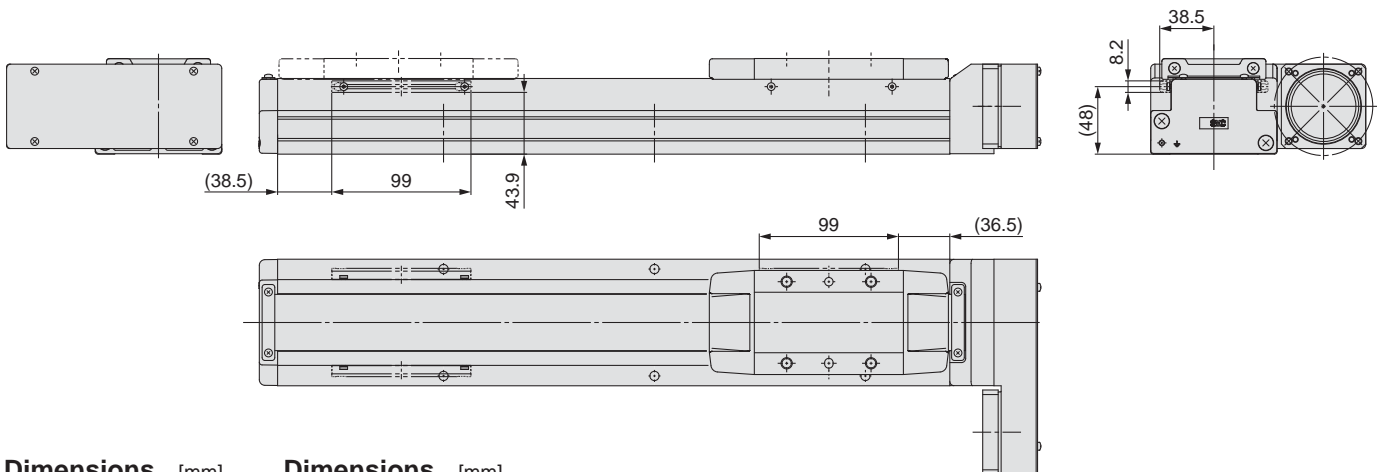

Dimensions [mm]

Stroke	G
150	130
200	280
250	280
300	280
350	430
400	430
450	430
500	580
550	580
600	580

Dimensions [mm]

Stroke	G
650	730
700	730
750	730
800	880
850	880
900	880
950	1030
1000	1030
1100	1180
1200	1180

Series LEFS

Motorless Type

- When mounting a hub, remove any oil, dust, or dirt from the shaft and hub inside diameter.
- This product does not include the motor and motor mounting screws. (Provided by user)
The motor drive shaft shape should be of the plain round type, without a keyway; except for the NM1 motor option which requires a flat (D-cut).
- Take measures to prevent the motor mounting screws becoming loose.

Motor Mounting: In-line

■ Motor type: NZ, NY, NX, NW, NV, NU, NT, NM2

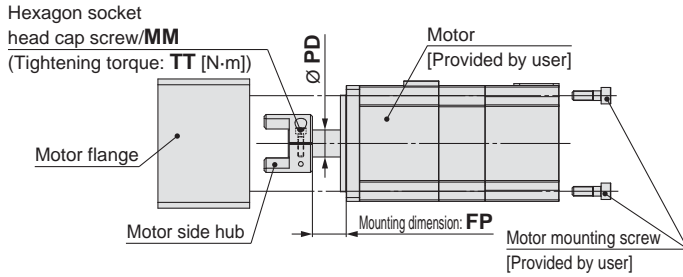

* Note for mounting a motor to the NM2 motor type
Motor mounting screws for the LEFS25 are fixed starting from the motor flange side. (Opposite of the drawing)

■ Motor type: NM1

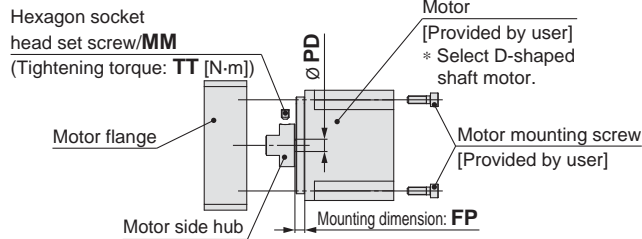

* Note for mounting a hub to the NM1 motor type
When mounting the hub to the motor, make sure to position the set screw perpendicular to the D-cut surface of the motor shaft. (Refer to the figure shown below.)
* Motor mounting screws for the LEFS25 are fixed starting from the motor flange side. (Opposite of the drawing)

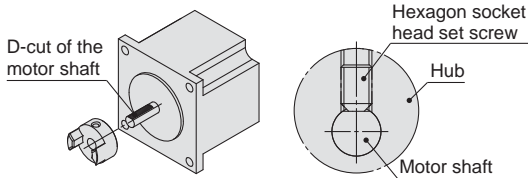

Size: 25 Hub Mounting Dimensions [mm]

Motor type	MM	TT	PD	FP
NZ	M2.5 x 10	1.00	8	12.4
NY	M2.5 x 10	1.00	8	12.4
NX	M2.5 x 10	1.00	8	6.9
NM1	M3 x 4	0.63	5	11.9
NM2	M2.5 x 10	1.00	6	10

Size: 32 Hub Mounting Dimensions [mm]

Motor type	MM	TT	PD	FP
NZ	M3 x 12	1.5	14	17.5
NY	M4 x 12	2.5	11	17.5
NX	M4 x 12	2.5	9	5.2
NW	M4 x 12	2.5	9	13
NV	M4 x 12	2.5	9	5.2
NU	M4 x 12	2.5	11	13
NT	M3 x 12	1.5	12	17.5
NM1	M4 x 5	1.5	6.35	5.4
NM2	M4 x 12	2.5	10	12

Size: 40 Hub Mounting Dimensions [mm]

Motor type	MM	TT	PD	FP
NZ	M3 x 12	1.5	14	17.5
NY	M3 x 12	1.5	14	17.5
NX	M4 x 12	2.5	9	5.2
NW	M4 x 12	2.5	9	13
NV	M4 x 12	2.5	9	5.2
NU	M4 x 12	2.5	11	13
NT	M3 x 12	1.5	12	17.5
NM1	M4 x 5	1.5	6.35	5.1
NM2	M4 x 12	2.5	10	12

Motor Mounting Diagram

Motor type: NZ, NY, NW, NU, NT

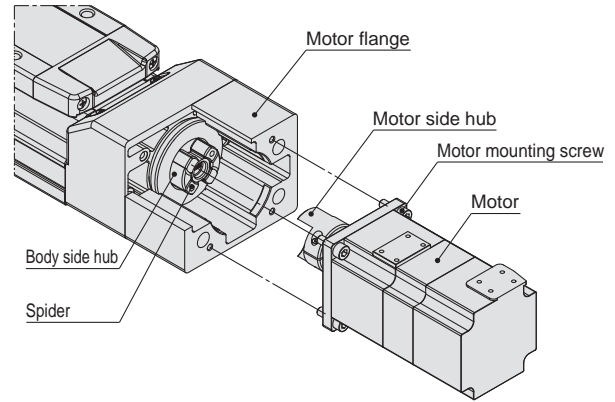

Mounting procedure

- 1) Fix the motor (provided by user) and the "motor hub" with the "MM hexagon socket head cap screw."
- 2) Check the "motor hub position", and then insert it.
- 3) Fix the motor and the "motor flange" with the motor mounting screws (provided by user).

Motor type: NX, NV, NM1, NM2

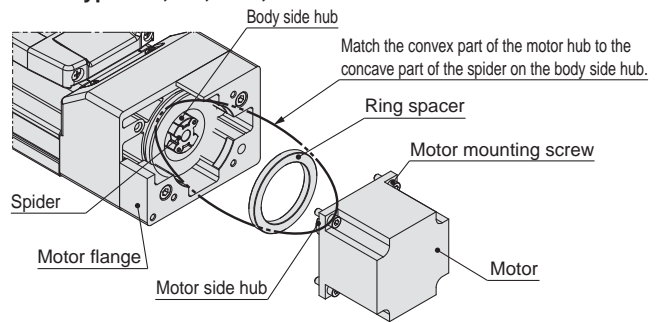

Mounting procedure

- 1) Fix the motor (provided by user) and the "motor hub" with the "MM hexagon socket head cap screw (Motor type: NX, NM2)" or "MM hexagon socket head set screw (Motor type: NM1)."
- 2) Check the "motor hub position", and then insert it.
- 3) Mount the "ring spacer" to the motor.
- 4) Fix the motor and the "motor flange" with the motor mounting screws (provided by user).
* For the LEFS25
- 4) Remove the "motor flange", which has been temporarily mounted, from the housing B, and secure the motor to the "motor flange" using the motor mounting screws (provided by user).
- 5) Tighten the "motor flange" to the "housing B" using the motor flange fixing screws (included parts).

Parts List

Size: 25

Description	Quantity					
	Motor type					
	NZ	NY	NX	NM1	NM2	
Motor side hub	1	1	1	1	1	
Hexagon socket head cap screw/set screw (for hub fixing)*	1	1	1	1	1	
Hexagon socket head cap screw (for motor flange fixing)*	—	—	—	2	2	
Ring spacer	—	—	—	1	1	

* For screw sizes, refer to the hub mounting dimensions.

Size: 32, 40

Description	Quantity											
	Motor type											
	NZ	NY	NX	NW	NV	NU	NT	NM1	NM2			
Motor side hub	1	1	1	1	1	1	1	1	1	1	1	
Hexagon socket head cap screw/set screw (for hub fixing)*	1	1	1	1	1	1	1	1	1	1	1	
Ring spacer	—	—	1	—	1	—	—	—	1	1	1	

* For screw sizes, refer to the hub mounting dimensions.

Motor Mounting: Motor Parallel

■ Motor type: NZ, NY, NX, NW, NU, NT, NM2

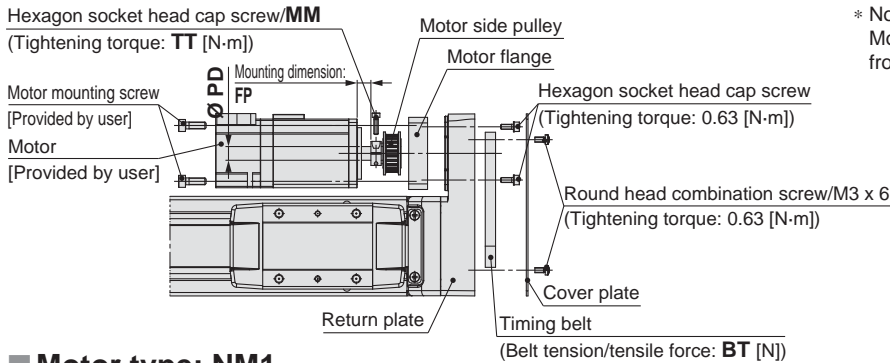

* Note for mounting a motor to the NM2 motor type
Motor mounting screws for the LEFS25 are fixed starting from the motor flange side. (Opposite of the drawing)

■ Motor type: NM1

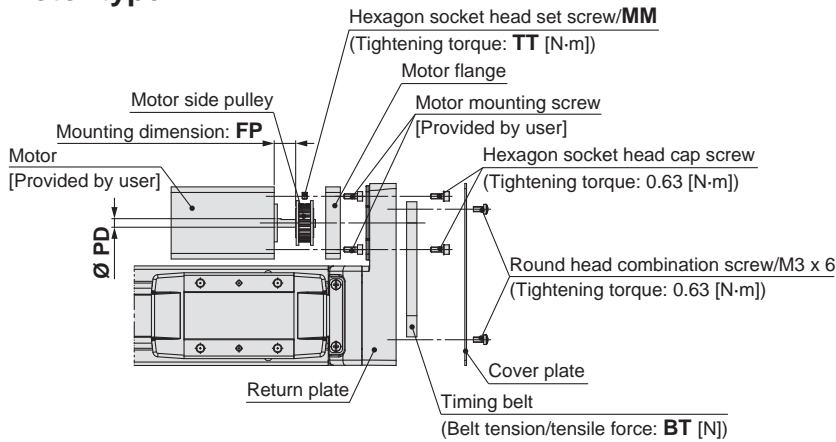

* Note for mounting a pulley to the NM1 motor type
When mounting the hub to the motor, make sure to position the set screw perpendicular to the D-cut surface of the motor shaft. (Refer to the figure shown below.)

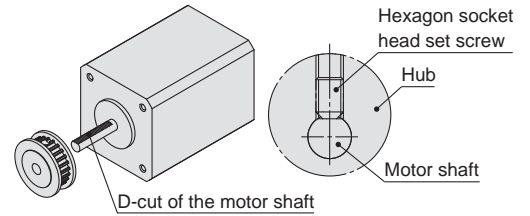

Motor Mounting Diagram

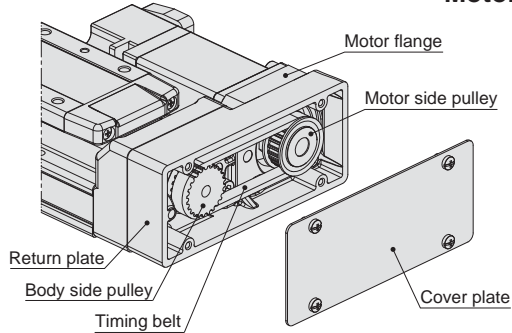

Mounting procedure

- 1) Fix the motor (provided by user) and the "motor side pulley" with the MM hexagon socket head cap screw. For motor type "NM 1", fix with the MM hexagon socket head set screw.
- 2) Fix the motor and the "motor flange" with the motor mounting screws (provided by user).
- 3) Put the "timing belt" on the "motor side pulley" and "body side pulley", and then fix it temporarily with the "hexagon socket head cap screws (2 x M3 x 8)."
- 4) Apply the belt tension and tighten the timing belt with the "hexagon socket head cap screws (2 x M3 x 8)."
- 5) Fix the "return plate" with the "round head combination screws (4 x M3 x 6)."

Size: 25 Hub Mounting Dimensions [mm]

Motor type	MM	TT	PD	FP	BT
NZ/NY	M2.5 x 10	1.00	8	8	19.6
NX	M2.5 x 10	1.00	8	5	19.6
NM1	M3 x 4	0.63	5	12.5	19.6
NM2	M2.5 x 10	1.00	6	5.5	19.6

Size: 32 Hub Mounting Dimensions [mm]

Motor type	MM	TT	PD	FP	BT
NZ	M3 x 12	1.50	14	6.6	49
NY	M3 x 12	1.50	11	6.6	49
NW	M4 x 12	2.50	9	6.6	49
NU	M3 x 12	1.50	11	4.2	49
NT	M3 x 12	1.50	12	10.6	49
NM1	M3 x 4	0.63	6.35	10.6	49
NM2	M3 x 12	1.50	10	5.1	49

Size: 40 Hub Mounting Dimensions [mm]

Motor type	MM	TT	PD	FP	BT
NZ/NY	M4 x 12	2.5	14	4.5	98.1
NW	M4 x 12	2.5	9	4.5	98.1
NT	M4 x 12	2.5	12	8	98.1

Parts List

Size: 25

Description	Q'ty
Motor flange	1
Motor side pulley	1
Cover plate	1
Timing belt	1
Hexagon socket head cap/set screw (for pulley fixing)*	1
Hexagon socket head cap screw M3 x 8 (for motor flange fixing)	2
Round head combination screw M3 x 6	4

* For screw sizes, refer to the hub mounting dimensions.

Size: 32, 40

Description	Q'ty	
	32	40
Motor flange	1	1
Motor side pulley	1	1
Cover plate	1	1
Timing belt	1	1
Hexagon socket head cap/set screw (for pulley fixing)*	1	1
Hexagon socket head cap screw M4 x 12 (for motor flange fixing)	2	4
Round head combination screw M3 x 6	4	4

* For screw sizes, refer to the hub mounting dimensions.

Series LEFS Motor Mounting Parts

Motor Flange Option

Using this option the motor can be replaced with the motor types shown below. (Except NM1 motor type uses a different hub, so it is not possible to replace LEFS□NM1□□ with other motor types)

Use the following part numbers to select a compatible motor flange option.

How to Order

LEFS-MF 25 □ - NZ

Ball screw drive

① ② ③

① Size

25	For LEF□25
32	For LEF□32
40	For LEF□40

② Motor mounting position

—	In-line
P	(Right side/Left side) parallel

③ Motor type

Symbol	Type	Symbol	Type
NZ	Mounting type Z	NV	Mounting type V
NY	Mounting type Y	NU	Mounting type U
NX	Mounting type X	NT	Mounting type T
NW	Mounting type W	NM2	Mounting type M2

* Select only NZ, NY, NX or NM2 for the LEFS-MF25.

Compatible Motors

Applicable motor model			Size/Motor type											
Manufacturer	Series	Type	25				32/40							
			NZ Mounting type Z	NY Mounting type Y	NX Mounting type X	NM2 Mounting type M2	NZ Mounting type Z	NY Mounting type Y	NX Mounting type X	NW Mounting type W	NV Mounting type V	NU Mounting type U	NT Mounting type T	NM2 Mounting type M2
Mitsubishi Electric Corporation	MELSERVO-JN	HF-KN	●	—	—	—	●	—	—	—	—	—	—	—
	MELSERVO-J3	KF-KP	●	—	—	—	●	—	—	—	—	—	—	—
	MELSERVO-J4	HG-KR	●	—	—	—	●	—	—	—	—	—	—	—
YASKAWA Electric Corporation	Σ-V	SGMJV	●	—	—	—	●	—	—	—	—	—	—	—
SANYO DENKI CO., LTD.	SANMOTION R	R2	●	—	—	—	●	—	—	—	—	—	—	—
OMRON Corporation	Sysmac G5	R88M-K	●	—	—	—	—	●	—	—	—	—	—	—
Panasonic Corporation	MINAS-A4	MSMD	—	●	—	—	—	—	●	—	—	—	—	—
	MINAS-A5	MSMD/MHMD	—	●	—	—	—	—	●	—	—	—	—	—
FANUC CORPORATION	βis	β	●	—	—	—	● (β1 only)	—	—	●	—	—	—	—
NIDEC SANKYO CORPORATION	S-FLAG	MA/MH/MM	●	—	—	—	●	—	—	—	—	—	—	—
KEYENCE CORPORATION	SV	SV-M/SV-B	●	—	—	—	●	—	—	—	—	—	—	—
FUJI ELECTRIC CO., LTD.	ALPHA5	GYS/GYB	●	—	—	—	●	—	—	—	—	—	—	—
	FALDIC-α	GYS	●	—	—	—	●	—	—	—	—	—	—	—
ORIENTAL MOTOR Co., Ltd.	AR/AZ	AR/AZ	—	—	—	●	—	—	—	—	—	—	—	●*2
Rockwell Automation, Inc. (Allen-Bradley)	MP-/VP-	MP/VP	—	—	—	—	—	—	●*1	—	—	—	—	—
	TL	TLY-A	●	—	—	—	—	—	—	—	—	—	●	—
Beckhoff Automation GmbH	AM	AM30	●	—	—	—	—	—	—	—	●*1	—	—	—
	AM	AM31	●	—	—	—	—	—	—	—	—	●*2	—	—
	AM	AM80/AM81	●	—	—	—	—	—	●*1	—	—	—	—	—
Siemens AG	1FK7	1FK7	—	—	●	—	—	—	—	●*1	—	—	—	—
	1FK2	1FK2	●	—	—	—	●	—	—	—	—	—	●	—
Delta Electronics, Inc.	ASDA-A2	ECMA	●	—	—	—	●	—	—	—	—	—	—	—

Note) When the LEF□□□NM1□□ is purchased, it is not possible to change to other motor types.

*1 Motor mounting position: In-line only

*2 Only size 32 is available when the motor mounting position is right (or left) side parallel.

Dimensions: Motor Flange Option

Motor mounting position: In-line

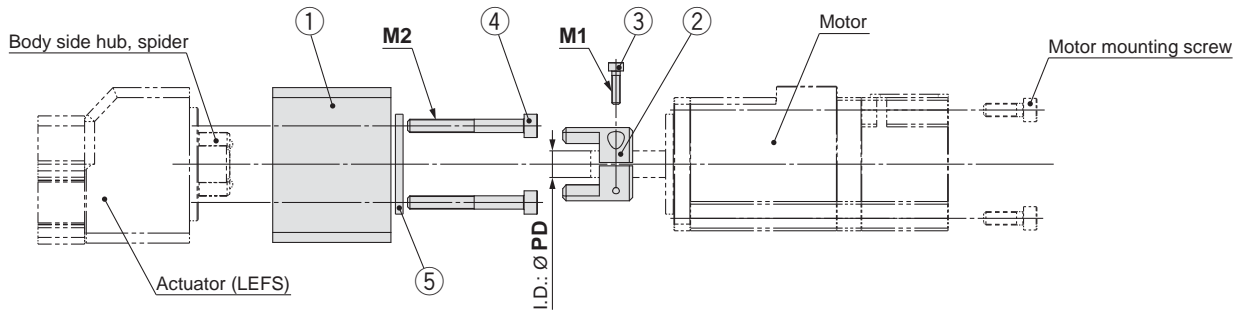

Component Parts

No.	Description	Quantity
1	Motor flange	1
2	Hub (Motor side)	1
3	Hexagon socket head cap screw (for hub fixing)	1
4	Hexagon socket head cap screw (for motor flange mounting)	2
5	Ring spacer (Only for NX, NV and NM2 of size 32, 40)	1

Motor flange details

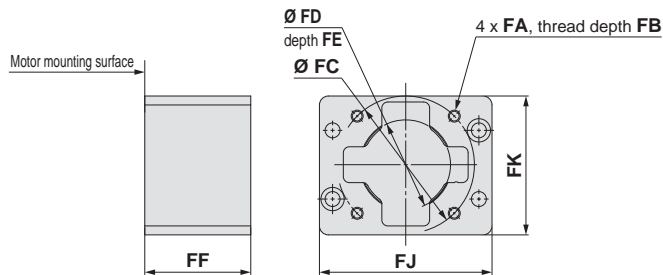

For NM2

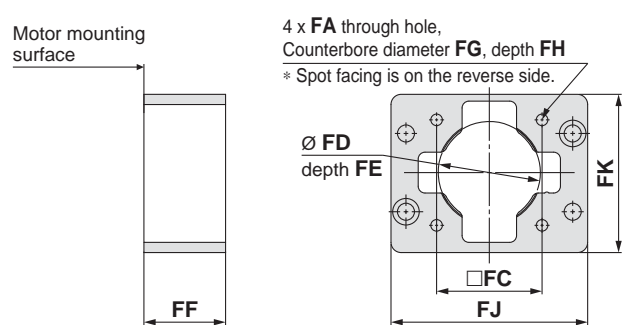

Dimensions

Size	Motor type	FA	FB	FC	FD	FE	FF	FG	FH	FJ	FK	M1	M2	PD
25	NZ/NX	M4 x 0.7	8	46	30	3.5	35.5	—	—	57.8	46.5	M2.5 x 10	M4 x 35	8
	NY	M3 x 0.5	8	45	30	3.5	35.5	—	—	57.8	46.5	M2.5 x 10	M4 x 35	8
	NM2	ø3.4	—	31	22*	2.5*	33.1	6.5	22.6	57.8	46.5	M2.5 x 10	M4 x 18	6
32	NZ	M5 x 0.8	9	70	50	5	46	—	—	69.8	61.4	M3 x 12	M5 x 40	14
	NY	M4 x 0.7	8	70	50	5	46	—	—	69.8	61.4	M4 x 12	M5 x 40	11
	NX	M5 x 0.8	9	63	50	5	49.7	—	—	69.8	61.4	M4 x 12	M5 x 40	9
	NW	M5 x 0.8	9	70	50	5	47.5	—	—	69.8	61.4	M4 x 12	M5 x 40	9
	NV	M4 x 0.7	8	63	50	5	49.7	—	—	69.8	61.4	M4 x 12	M5 x 40	9
	NU	M5 x 0.8	9	70	50	5	47.5	—	—	69.8	61.4	M4 x 12	M5 x 40	11
	NT	M5 x 0.8	9	70	50	5	46	—	—	69.8	61.4	M3 x 12	M5 x 40	12
	NM2	M4 x 0.7	8	50	36*	4.5*	40.1	—	—	69.8	61.4	M4 x 12	M5 x 25	10
40	NZ	M5 x 0.8	9	70	50	5	47.5	—	—	89.8	66.9	M3 x 12	M5 x 40	14
	NY	M4 x 0.7	8	70	50	5	47.5	—	—	89.8	66.9	M3 x 12	M5 x 40	14
	NX	M5 x 0.8	9	63	50	5	51	—	—	89.8	66.9	M4 x 12	M5 x 40	9
	NW	M5 x 0.8	9	70	50	5	48.8	—	—	89.8	66.9	M4 x 12	M5 x 40	9
	NV	M4 x 0.7	8	63	50	5	51	—	—	89.8	66.9	M4 x 12	M5 x 40	9
	NU	M5 x 0.8	9	70	50	5	48.8	—	—	89.8	66.9	M4 x 12	M5 x 40	11
	NT	M5 x 0.8	9	70	50	5	47.5	—	—	89.8	66.9	M3 x 12	M5 x 40	12
	NM2	M4 x 0.7	8	50	36*	4.5*	41.4	—	—	89.8	66.9	M4 x 12	M5 x 25	10

* Dimensions after mounting a ring spacer

Series LEFS

Dimensions: Motor Flange Option

Motor mounting position: Motor parallel

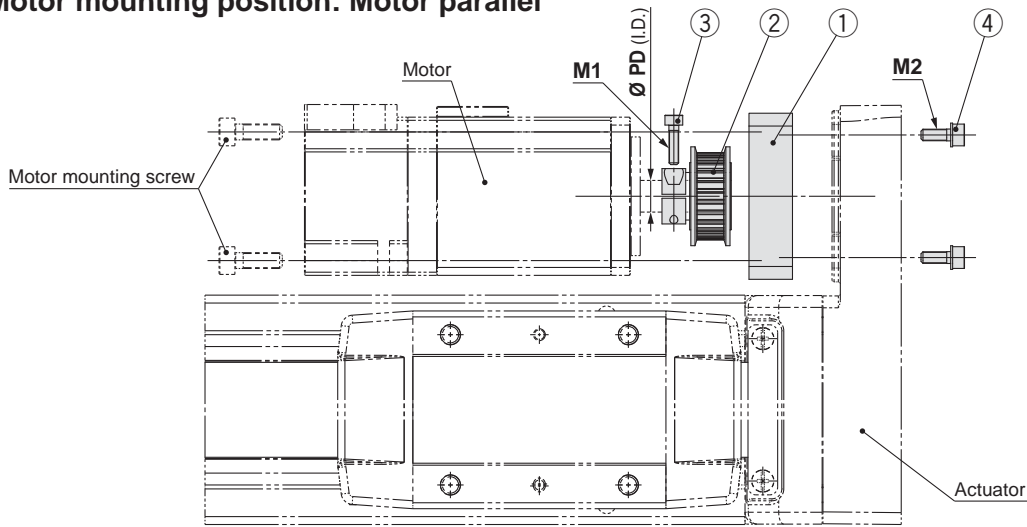

Component Parts

No.	Description	Quantity	
		25, 32	40
1	Motor flange	1	1
2	Motor pulley	1	1
3	Hexagon socket head cap screw (for pulley fixing)	1	1
4	Hexagon socket head cap screw (for motor flange mounting)	2	4

Motor flange details

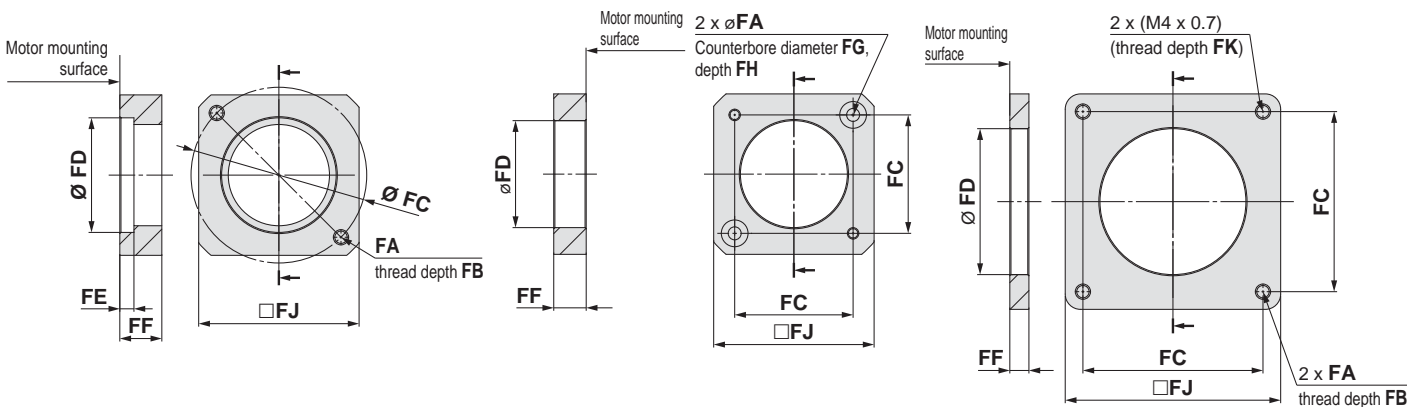

Dimensions

Size	Motor type	FA	FB	FC	FD	FE	FF	FG	FH	FJ	FK	M1	M2	PD
25	NZ	2 x M4 x 0.7	7.5	46	30	3.7	11	—	—	42	—	M2.5 x 10	M3 x 8	8
	NY	2 x M3 x 0.5	5.5	45	30	5	11	—	—	38	—	M2.5 x 10	M3 x 8	8
	NX	2 x M4 x 0.7	7	46	30	3.7	8	—	—	42	—	M2.5 x 10	M3 x 8	8
	NM2	∅3.4	—	31	28	—	8.5	7	3.5	42	—	M2.5 x 10	M3 x 8	6
32	NZ	2 x M5 x 0.8	8.5	70	50	4.6	13	—	—	60	—	M3 x 12	M4 x 12	14
	NY	2 x M4 x 0.7	8	70	50	4.6	13	—	—	60	—	M3 x 12	M4 x 12	11
	NW	2 x M5 x 0.8	8.5	70	50	4.6	13	—	—	60	—	M4 x 12	M4 x 12	9
	NU	2 x M5 x 0.8	8.5	70	50	4.6	10.6	—	—	60	—	M3 x 12	M4 x 12	11
	NT	2 x M5 x 0.8	8.5	70	50	4.6	17	—	—	60	—	M3 x 12	M4 x 12	12
	NM2	M4 x 0.7	8	50	38.2	—	11.5	—	—	60	7	M3 x 12	M4 x 12	10
40	NZ	4 x M5 x 0.8	8.5	70	50	4.6	11	—	—	60	—	M4 x 12	M4 x 12	14
	NY	4 x M4 x 0.7	8	70	50	4.6	11	—	—	60	—	M4 x 12	M4 x 12	14
	NW	4 x M5 x 0.8	8.5	70	50	4.6	11	—	—	60	—	M4 x 12	M4 x 12	9
	NT	4 x M5 x 0.8	8.5	70	50	4.6	14.5	—	—	60	—	M4 x 12	M4 x 12	12

Motorless Type Electric Actuator/Slider Type Ball Screw Drive/Series **LEFB** Model Selection



Selection Procedure



Selection Example

Operating conditions

- Workpiece weight: 20 [kg]
- Speed: 1500 [mm/s]
- Acceleration/Deceleration: 3000 [mm/s²]
- Stroke: 2000 [mm]
- Mounting position: Horizontal
- Workpiece mounting condition:

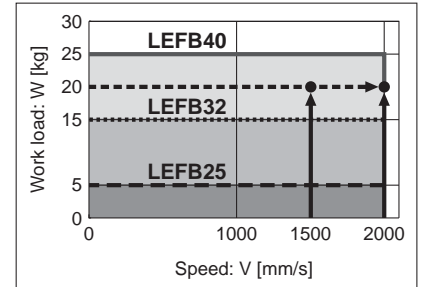
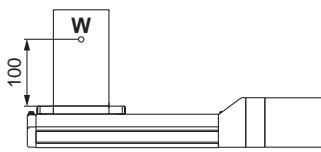

<Speed-Work Load Graph>
(LEFB40)

Step 1 Check the work load-speed. <Speed-Work Load Graph>

Select a model based on the workpiece mass and speed, within the range of the actuator specifications, while referring to the "Speed-Work Load Graph (Guide)" on page 33.

Selection example) The **LEFB40□S-2000** is provisionally selected based on the graph on the right.

* Refer to the motor manufacturers catalogue for details on the regeneration resistance.

Step 2 Check the cycle time.

Calculate the **cycle time** using the following calculation method.

Cycle time:

T can be found from the following equation.

$$T = T1 + T2 + T3 + T4 \text{ [s]}$$

- T1: Acceleration time and T3: Deceleration time can be found from the following equation.

$$T1 = V/a1 \text{ [s]} \quad T3 = V/a2 \text{ [s]}$$

- T2: Constant speed time can be found from the following equation.

$$T2 = \frac{L - 0.5 \cdot V \cdot (T1 + T3)}{V} \text{ [s]}$$

- T4: Settling time varies depending on the motor type and load. The value below is recommended.

$$T4 = 0.05 \text{ [s]}$$

* The conditions for the settling time vary depending on the motor or driver to be used.

Calculation example)

T1 to T4 can be calculated as follows.

$$T1 = V/a1 = 1500/3000 = 0.5 \text{ [s]}$$

$$T3 = V/a2 = 1500/3000 = 0.5 \text{ [s]}$$

$$T2 = \frac{L - 0.5 \cdot V \cdot (T1 + T3)}{V} = \frac{2000 - 0.5 \cdot 1500 \cdot (0.5 + 0.5)}{1500} = 0.83 \text{ [s]}$$

$$T4 = 0.05 \text{ [s]}$$

Therefore, the **cycle time** can be calculated as follows.

$$T = T1 + T2 + T3 + T4 = 0.5 + 0.83 + 0.5 + 0.05 = 1.88 \text{ [s]}$$

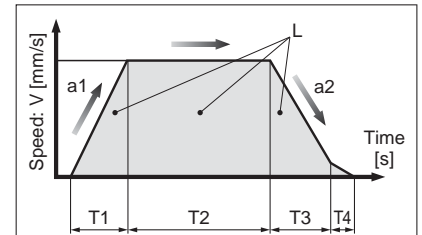

L : Stroke [mm]

... (Operating condition)

V : Speed [mm/s]

... (Operating condition)

a1: Acceleration [mm/s²]

... (Operating condition)

a2: Deceleration [mm/s²]

... (Operating condition)

T1: Acceleration time [s]

Time until the set speed is reached

T2: Constant speed time [s]

Time when the actuator is operating at a constant speed

T3: Deceleration time [s]

Time from the constant speed operation until movement stops

T4: Settling time [s]

Time until positioning is completed

Step 3 Check the guide moment.

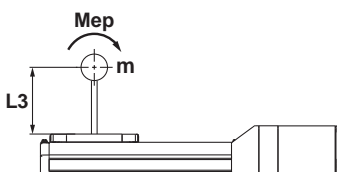

Based on the above calculation result, the **LEFB40□S-2000** can be selected.

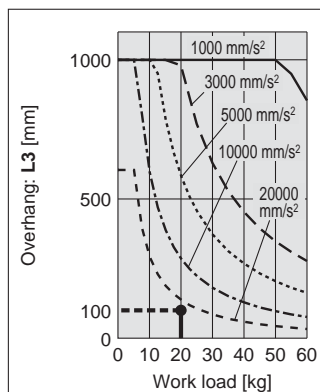

Series LEFB

Motorless Type

* The values given below are within the actuator body specification ranges and should not be exceeded.

Speed-Work Load Graph (Guide)

LEFB□/Belt Drive

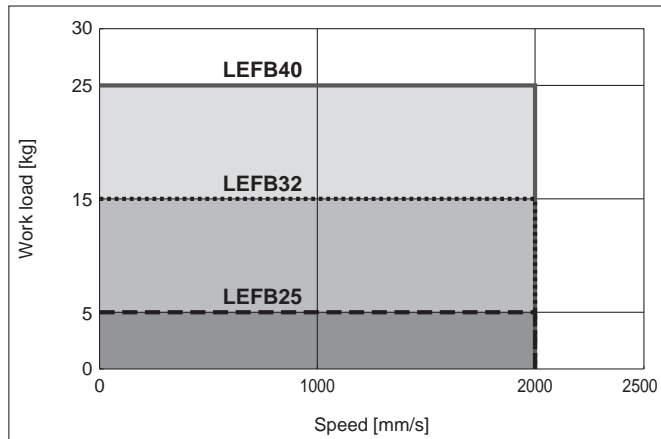

Work Load-Acceleration/Deceleration Graph (Guide)

LEFB□/Belt Drive

LEFB25□ (Duty ratio)

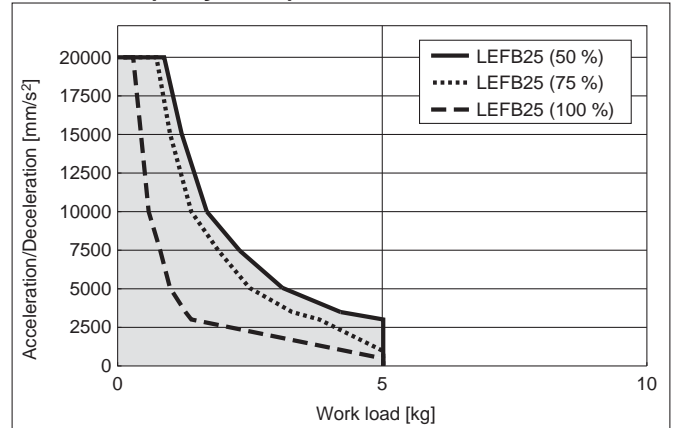

Cycle Time Graph (Guide)

LEFB□/Belt Drive

LEFB25/32/40

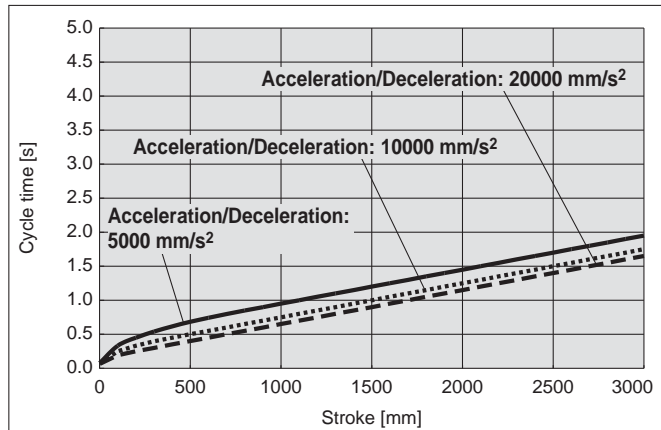

* Cycle time is for when maximum speed.

* Maximum stroke: LEFB25: 2000 mm
LEFB32: 2500 mm
LEFB40: 3000 mm

LEFB32□ (Duty ratio)

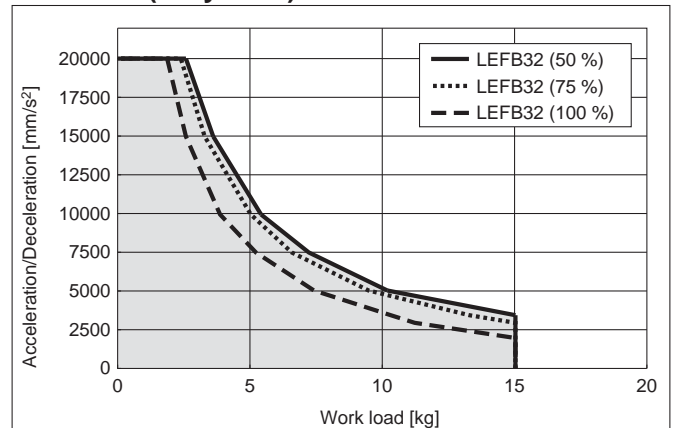

LEFB40□ (Duty ratio)

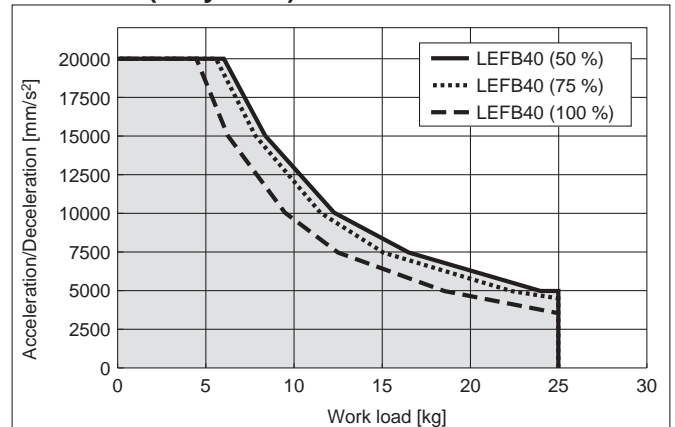

These graphs are examples of when the standard motor is mounted.
Determine the duty ratio after taking into account the load factor of the motor or driver to be used.

Dynamic Allowable Moment

* This graph shows the amount of allowable overhang (guide unit) when the centre of gravity of the workpiece overhangs in one direction. When selecting the overhang, refer to "Calculation of Guide Load Factor" or the Electric Actuator Selection Software for confirmation, <http://www.smc.eu>

Acceleration/Deceleration ——— 1000 mm/s² - - - 3000 mm/s² ······ 5000 mm/s² - - - - 10000 mm/s² - - - - - 20000 mm/s²

Orientation		Model		
Load overhanging direction m : Work load [kg] Me: Dynamic allowable moment [N·m] L : Overhang to the work load centre of gravity [mm]		LEFB25□	LEFB32□	LEFB40□
Horizontal	X 			
	Y 			
	Z 			
Wall mounted	X 			
	Y 			
	Z 			

- Model Selection
- LEFS
- LEFB
- LEJS
- LEY
- LEYG
- Motor Mounting

Calculation of Guide Load Factor

1. Determine the operating conditions.

Model: LEFB

Size: 25/32/40

Mounting orientation: Horizontal/Wall mounted/Vertical

Acceleration [mm/s²]: **a**

Work load [kg]: **m**

Work load centre position [mm]: **Xc/Yc/Zc**

2. Select the target graph with reference to the model, size and mounting orientation.

3. Based on the acceleration and work load, obtain the overhang [mm]: **Lx/Ly/Lz** from the graph.

4. Calculate the load factor for each direction.

$$\alpha_x = X_c/L_x, \alpha_y = Y_c/L_y, \alpha_z = Z_c/L_z$$

5. Confirm the total of α_x , α_y and α_z is 1 or less.

$$\alpha_x + \alpha_y + \alpha_z \leq 1$$

When 1 is exceeded, please consider a reduction of acceleration and work load, or a change of the work load centre position or the actuator series.

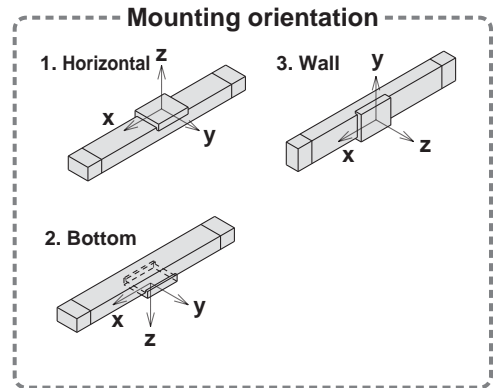

Example

1. Operating conditions

Model: LEFB40

Size: 40

Mounting orientation: Horizontal

Acceleration [mm/s²]: 3000

Work load [kg]: 20

Work load centre position [mm]: **Xc = 0, Yc = 50, Zc = 200**

3. **Lx = 250 mm, Ly = 180 mm, Lz = 1000 mm**

4. The load factor for each direction can be calculated as follows.

$$\alpha_x = 0/250 = 0$$

$$\alpha_y = 50/180 = 0.27$$

$$\alpha_z = 200/1000 = 0.2$$

5. $\alpha_x + \alpha_y + \alpha_z = 0.47 \leq 1$

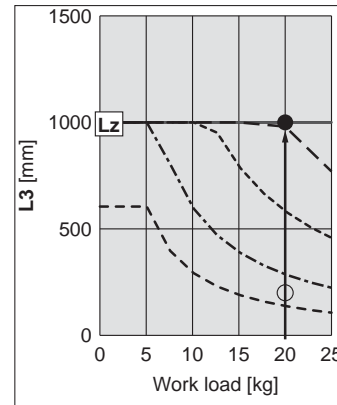
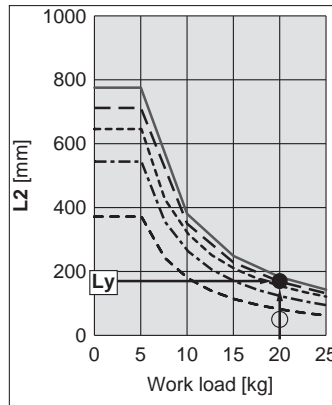
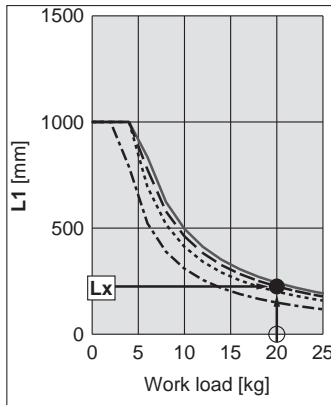
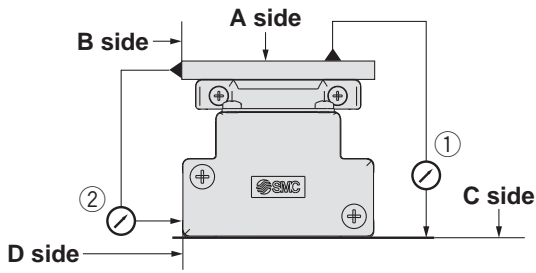

Table Accuracy (Reference Value)



Model	Parallelism of travel [mm] (Every 300 mm)	
	① C side parallelism to A side	② D side parallelism to B side
LEFB25	0.05	0.03
LEFB32	0.05	0.03
LEFB40	0.05	0.03

Note) Parallelism of travel does not include the mounting surface accuracy.

Table Displacement (Reference Value)

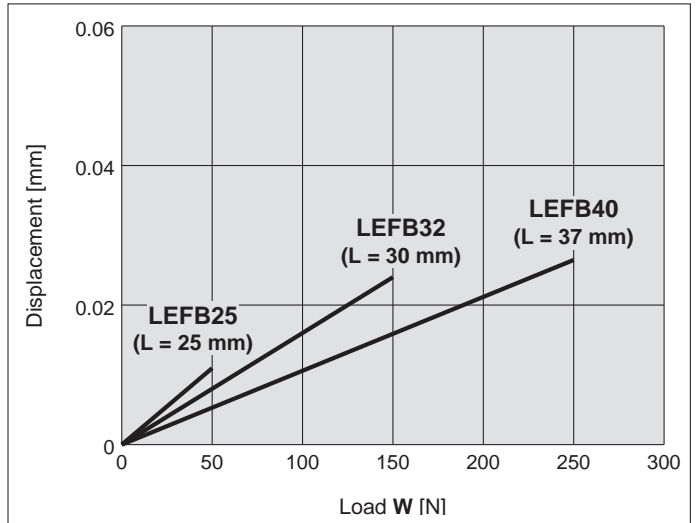
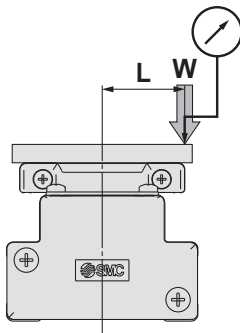

Note 1) This displacement is measured when a 15 mm aluminium plate is mounted and fixed on the table.

Note 2) Check the clearance and play of the guide separately.

Overhang Displacement Due to Table Clearance (Reference Value)

Basic type

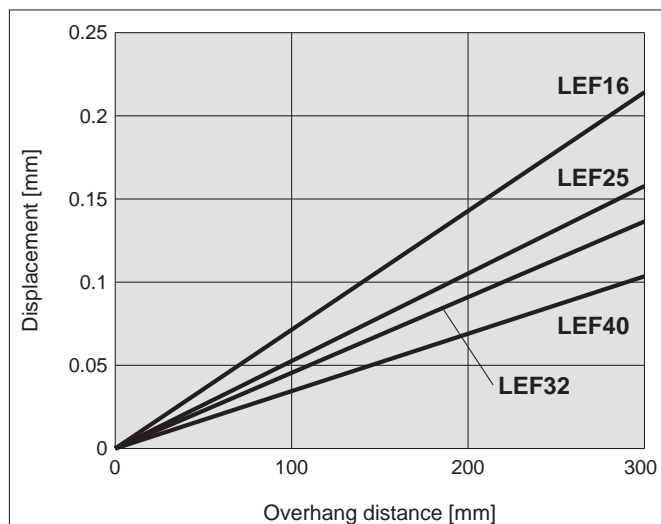

High precision type

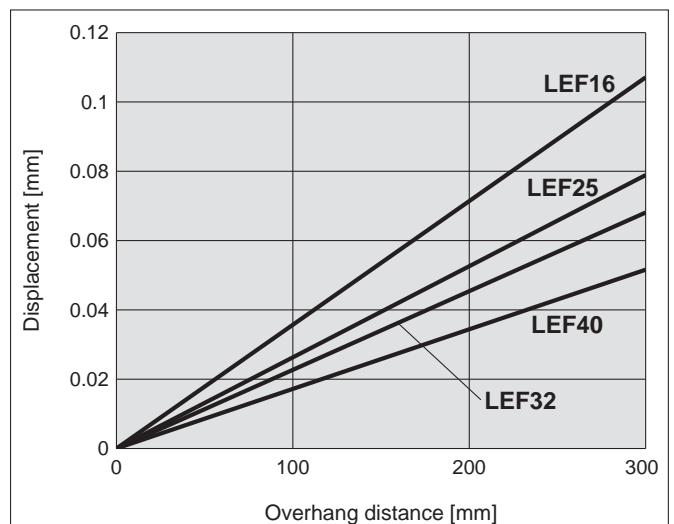

Electric Actuator/Slider Type Belt Drive

Series **LEFB** LEFB25, 32, 40



How to Order

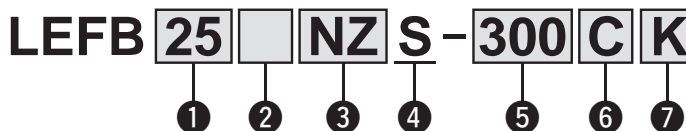

① Size

25
32
40

② Motor mounting position

—	Top mounting
U	Bottom mounting

③ Motor type

Symbol	Type
NZ	Mounting type Z
NY	Mounting type Y
NX	Mounting type X
NW	Mounting type W
NV	Mounting type V
NU	Mounting type U
NT	Mounting type T
NM1	Mounting type M1
NM2	Mounting type M2

④ Equivalent lead [mm]

S	54
---	----

⑤ Stroke [mm]

300	300
to	to
3000	3000

* Refer to the applicable stroke table.

⑥ Auto Switch mounting bracket

—	None
C	With 1 pc. (included)

* If 2 or more are required, please order them separately. (Part no.: LEF-D-2-1 For details, refer to page 54.)

* Order auto switches separately. (For details, refer to pages 55 and 56.)

⑦ Positioning pin hole

—	Housing B bottom	
K	Body bottom 2 locations	

* Refer to the body mounting example on page 58 for the mounting method.

Applicable Stroke Table

●: Standard/○: Produced upon receipt of order [mm]

Model	300	400	500	600	700	800	900	1000	1100	1200	1300	1400	1500	1600	1700	1800	1900	2000	2500	3000
LEFB25	●	●	●	●	●	●	●	●	○	●	○	○	●	○	○	○	○	●	—	—
LEFB32	●	●	●	●	●	●	●	●	○	●	○	○	●	○	○	○	○	●	●	—
LEFB40	●	●	●	●	●	●	●	●	○	●	○	○	●	○	○	○	○	●	●	●

* Please consult with SMC as all non-standard strokes are produced as special orders.

Compatible Motors

Applicable motor model			Size/Motor type																	
Manufacturer	Series	Type	25					32/40												
			NZ Mounting type Z	NY Mounting type Y	NX Mounting type X	NM1 Mounting type M1	NM2 Mounting type M2	NZ Mounting type Z	NY Mounting type Y	NX Mounting type X	NW Mounting type W	NV Mounting type V	NU Mounting type U	NT Mounting type T	NM1 Mounting type M1	NM2 Mounting type M2				
Mitsubishi Electric Corporation	MELSERVO-JN	HF-KN	●	—	—	—	—	●	—	—	—	—	—	—	—	—	—	—	—	—
	MELSERVO-J3	HF-KP	●	—	—	—	—	●	—	—	—	—	—	—	—	—	—	—	—	—
	MELSERVO-J4	HG-KR	●	—	—	—	—	●	—	—	—	—	—	—	—	—	—	—	—	—
YASKAWA Electric Corporation	Σ-V	SGMJV	●	—	—	—	—	●	—	—	—	—	—	—	—	—	—	—	—	—
SANYO DENKI CO., LTD.	SANMOTION R	R2	●	—	—	—	—	●	—	—	—	—	—	—	—	—	—	—	—	—
OMRON Corporation	Sysmac G5	R88M-K	●	—	—	—	—	—	●	—	—	—	—	—	—	—	—	—	—	—
Panasonic Corporation	MINAS-A4	MSMD	—	●	—	—	—	—	—	●	—	—	—	—	—	—	—	—	—	—
	MINAS-A5	MSMD/MHMD	—	●	—	—	—	—	—	●	—	—	—	—	—	—	—	—	—	—
FANUC CORPORATION	βis	β	●	—	—	—	—	—	●	—	—	●	—	—	—	—	—	—	—	—
NIDEC SANKYO CORPORATION	S-FLAG	MA/MH/MM	●	—	—	—	—	—	●	—	—	—	—	—	—	—	—	—	—	—
KEYENCE CORPORATION	SV	SV-M/SV-B	●	—	—	—	—	—	●	—	—	—	—	—	—	—	—	—	—	—
FUJI ELECTRIC CO., LTD.	ALPHA5	GYS/GYB	●	—	—	—	—	—	●	—	—	—	—	—	—	—	—	—	—	—
	FALDIC-α	GYS	●	—	—	—	—	—	●	—	—	—	—	—	—	—	—	—	—	—
ORIENTAL MOTOR Co., Ltd.	AR/AZ	AR/AZ	—	—	—	—	—	●	—	—	—	—	—	—	—	—	—	—	—	●
FASTECH Co., Ltd.	Ezi-SERVO	EzM	—	—	—	—	●	—	—	—	—	—	—	—	—	—	—	—	●	—
Rockwell Automation, Inc. (Allen-Bradley)	MP-/VP-	MP/VP	—	—	—	—	—	—	—	—	●	—	—	—	—	—	—	—	—	—
	TL	TLY-A	●	—	—	—	—	—	—	—	—	—	—	—	—	—	—	●	—	—
Beckhoff Automation GmbH	AM	AM30	●	—	—	—	—	—	—	—	—	—	—	—	—	—	—	●	—	—
	AM	AM31	●	—	—	—	—	—	—	—	—	—	—	—	—	—	—	●	—	—
	AM	AM80/AM81	●	—	—	—	—	—	—	—	—	●	—	—	—	—	—	—	—	—
Siemens AG	1FK7	1FK7	—	—	—	●	—	—	—	—	—	—	—	●	—	—	—	—	—	—
	1FK2	1FK2	●	—	—	—	—	—	—	●	—	—	—	—	—	—	—	●	—	—
Delta Electronics, Inc.	ASDA-A2	ECMA	●	—	—	—	—	—	—	—	●	—	—	—	—	—	—	—	—	—

Specifications Note 2)

• The values given below are within the actuator body specification range, with a standard motor mounted and should not be exceeded.

Model		LEFB25	LEFB32	LEFB40
Actuator specifications	Stroke [mm] <small>Note 1)</small>	300, 400, 500 600, 700, 800 900, 1000, (1100) 1200, (1300, 1400) 1500, (1600, 1700) (1800, 1900), 2000	300, 400, 500 600, 700, 800 900, 1000, (1100) 1200, (1300, 1400) 1500, (1600, 1700) (1800, 1900), 2000 2500	300, 400, 500 600, 700, 800 900, 1000, (1100) 1200, (1300, 1400) 1500, (1600, 1700) (1800, 1900), 2000 2500, 3000
	Work load [kg]	Horizontal		5
	Speed [mm/s]	2000		
	Pushing return to origin speed [mm/s]	30 or less		
	Positioning repeatability [mm]	±0.06		
	Lost motion [mm] <small>Note 3)</small>	0.1 or less		
	Equivalent lead [mm]	54		
	Max. acceleration/deceleration [mm/s ²]	20000 <small>Note 4)</small>		
	Impact/Vibration resistance [m/s ²]	50/20		
	Actuation type	Belt		
	Guide type	Linear guide		
	Operating temperature range [°C]	5 to 40		
	Operating humidity range [%RH]	90 or less (No condensation)		
Other specifications <small>Note 5)</small>	Actuation unit weight [kg]	0.2	0.3	0.55
	Other inertia [kg·cm ²]	0.1	0.2	0.25
	Coefficient of friction	0.05		
	Mechanical efficiency	0.8		
Reference motor specifications	Motor shape	<input type="checkbox"/> 40	<input type="checkbox"/> 60	
	Motor type	AC servo motor (100 V/200 V)		
	Rated output capacity [W]	100	200	400
	Rated torque [N·m]	0.32	0.64	1.3
	Rated rotation [rpm]	3000		

Note 1) Please consult with SMC as all non-standard and non-made-to-order strokes are produced as special orders.

Note 2) Do not allow collisions at either end of the table at a speed exceeding "pushing return to origin speed."

Additionally, when running the positioning operation, do not set within 3 mm of either end.

Note 3) A reference value for correcting an error in reciprocal operation.

Note 4) Maximum acceleration/deceleration will vary according to the work load.

Refer to the "Work Load–Acceleration/Deceleration Graph (Guide)" for belt drive on page 33..

Note 5) The values are a guide only and should be used to select a motor capacity.

Weight

Model	LEFB25																	
Stroke [mm]	300	400	500	600	700	800	900	1000	1100	1200	1300	1400	1500	1600	1700	1800	1900	2000
Weight [kg]	2.5	2.75	3	3.25	3.5	3.75	4	4.25	4.5	4.75	5	5.25	5.5	5.75	6	6.25	6.5	6.75

Model	LEFB32																		
Stroke [mm]	300	400	500	600	700	800	900	1000	1100	1200	1300	1400	1500	1600	1700	1800	1900	2000	2500
Weight [kg]	4.00	4.35	4.70	5.05	5.40	5.75	6.10	6.45	6.80	7.15	7.50	7.85	8.20	8.55	8.90	9.25	9.60	9.95	11.70

Model	LEFB40																				
Stroke [mm]	300	400	500	600	700	800	900	1000	1100	1200	1300	1400	1500	1600	1700	1800	1900	2000	2500	3000	
Weight [kg]	5.72	6.17	6.62	7.07	7.52	7.97	8.42	8.87	9.32	9.77	10.22	10.67	11.12	11.57	12.02	12.47	12.92	13.37	15.62	17.87	

Model Selection
 LEFS
 LEFB
 LEJS
 LEY
 LEYG
 Motor Mounting

Series LEFB

Motorless Type

Refer to the "Motor Mounting" on page 51 for details of motor mounting and parts included.

Dimensions: Belt Drive

LEFB25/Motor top mounting type

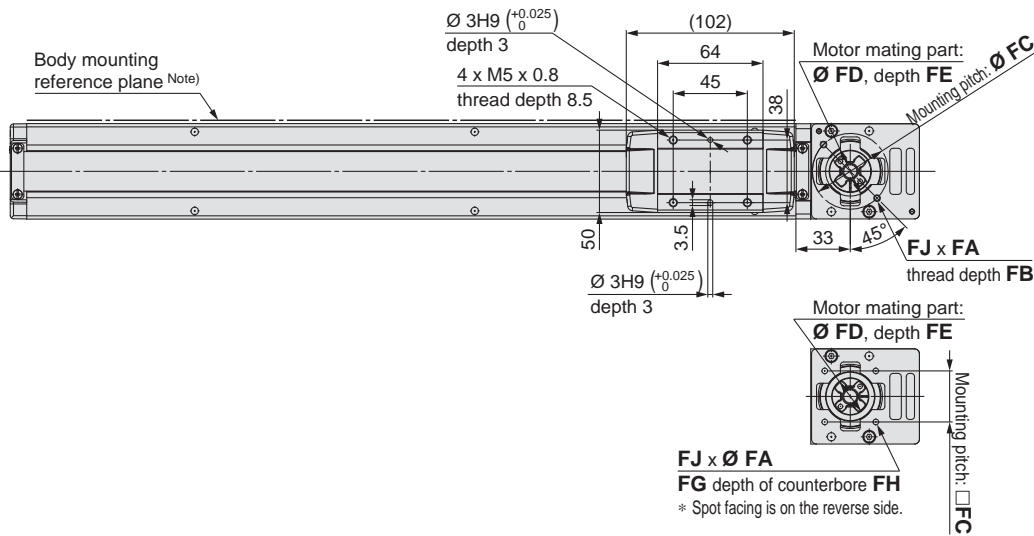
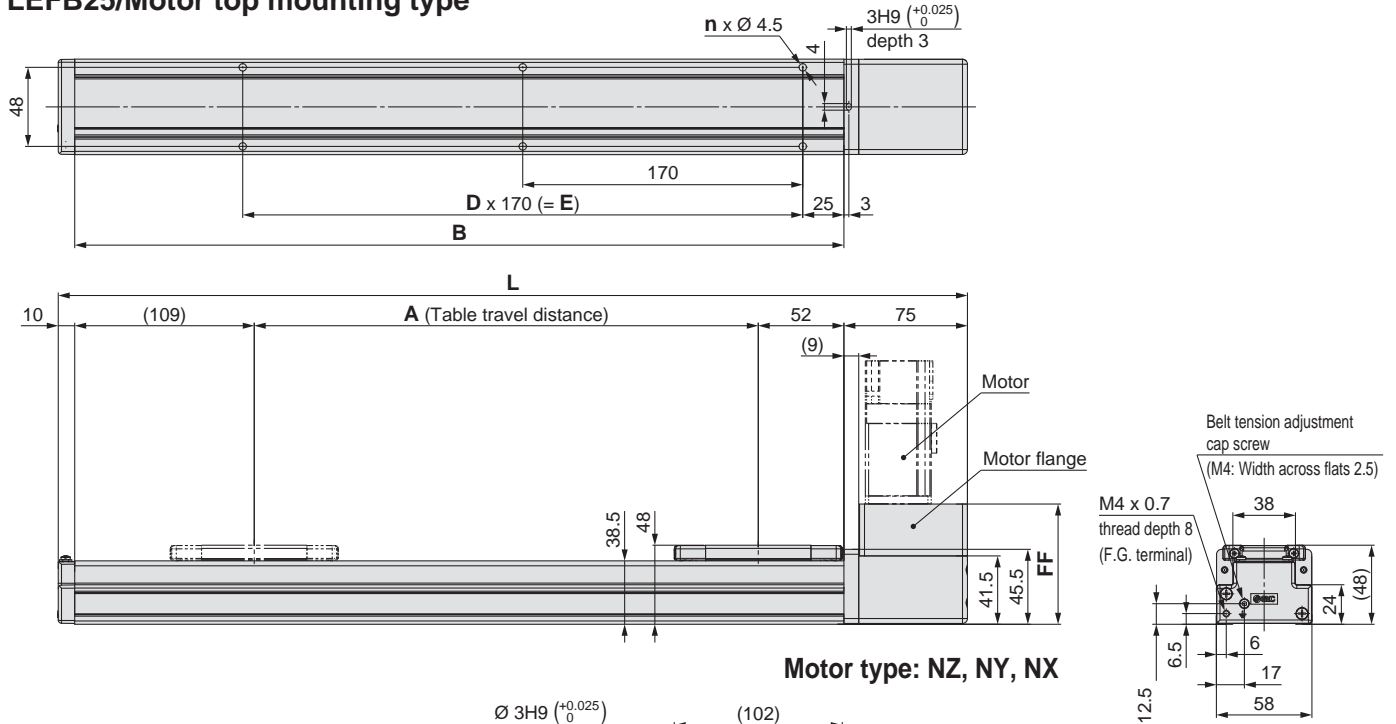

Dimensions

Stroke	L	A	B	n	D	E
300	552	306	467	6	2	340
400	652	406	567	8	3	510
500	752	506	667	8	3	510
600	852	606	767	10	4	680
700	952	706	867	10	4	680
800	1052	806	967	12	5	850
900	1152	906	1067	14	6	1020
1000	1252	1006	1167	14	6	1020
1100	1352	1106	1267	16	7	1190
1200	1452	1206	1367	16	7	1190
1300	1552	1306	1467	18	8	1360
1400	1652	1406	1567	20	9	1530
1500	1752	1506	1667	20	9	1530
1600	1852	1606	1767	22	10	1700
1700	1952	1706	1867	22	10	1700
1800	2052	1806	1967	24	11	1870
1900	2152	1906	2067	24	11	1870
2000	2252	2006	2167	26	12	2040

Note) When mounting the actuator using the body mounting reference plane, set the height of the mating surface or positioning pins to 3 mm minimum. (Recommended height 5 mm)

Motor Mounting Dimensions

Motor type	FA	FB	FC	FD	FE	FF	FG	FH	FJ
NZ	M4 x 0.7	8	46	30	3.5	73	—	—	2
NY	M3 x 0.5	8	45	30	3.5	73	—	—	4
NX	M4 x 0.7	8	46	30	3.5	73	—	—	2
NM1/NM2	3.4	—	31	22*	2.5*	73	6	21	4

* Dimensions after mounting a ring spacer (Refer to page 51.)

Refer to the "Motor Mounting" on page 51 for details about motor mounting and included parts.

Dimensions: Belt Drive

LEFB25/Motor top mounting type

Positioning pin hole ^{Note)} (Option): Body bottom

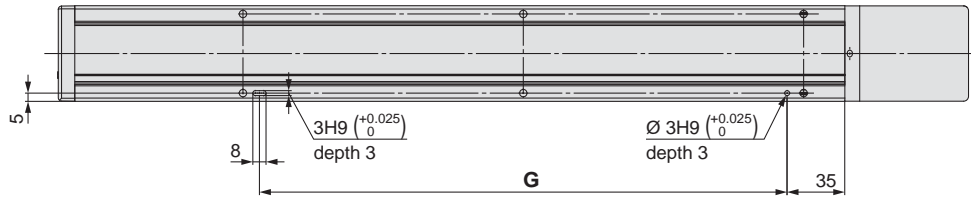

Note) When using the body bottom positioning pin holes, do not simultaneously use the housing B bottom pin hole.

With auto switch (Option)

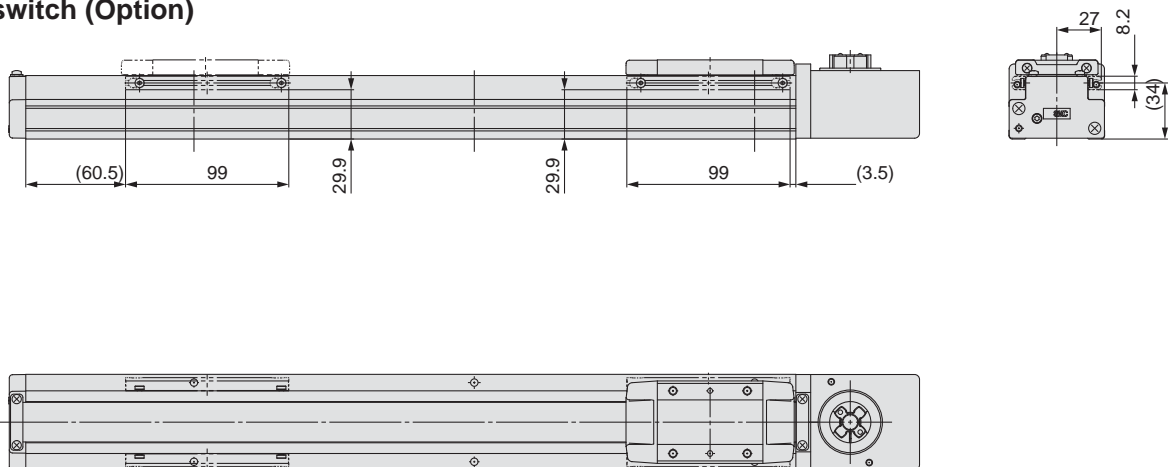

Dimensions [mm]

Stroke	G
300	320
400	490
500	490
600	660
700	660
800	830
900	1000
1000	1000
1100	1170
1200	1170
1300	1340
1400	1510
1500	1510
1600	1680
1700	1680
1800	1850
1900	1850
2000	2020

Refer to the "Motor Mounting" on page 51 for details of motor mounting and parts included.

Dimensions: Belt Drive

LEFB25U/Motor bottom mounting type

Motor type: NM1, NM2

Motor mating part: \varnothing FD, depth FE

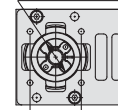

Mounting pitch: \varnothing FC

Motor type: NZ, NY, NX

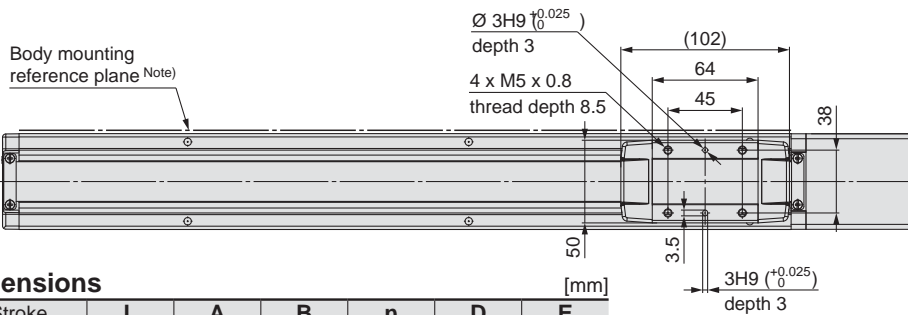
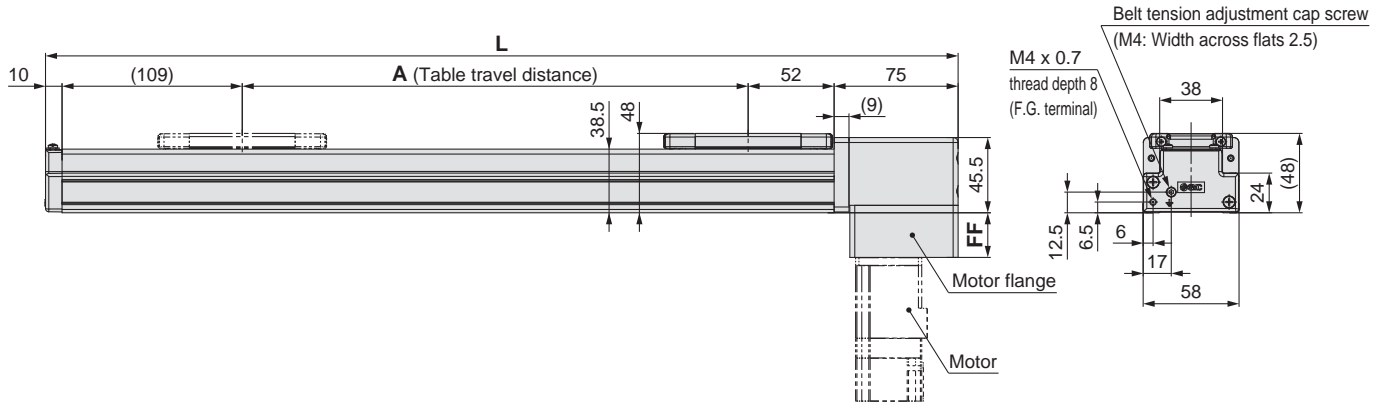
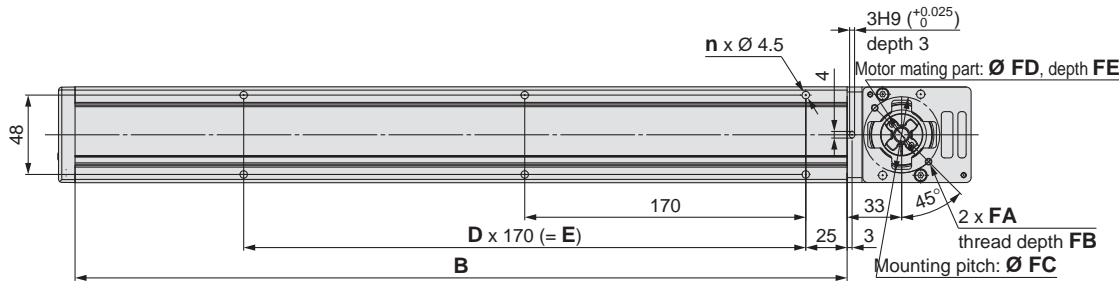

Dimensions

Stroke	L	A	B	n	D	E
300	552	306	467	6	2	340
400	652	406	567	8	3	510
500	752	506	667	8	3	510
600	852	606	767	10	4	680
700	952	706	867	10	4	680
800	1052	806	967	12	5	850
900	1152	906	1067	14	6	1020
1000	1252	1006	1167	14	6	1020
1100	1352	1106	1267	16	7	1190
1200	1452	1206	1367	16	7	1190
1300	1552	1306	1467	18	8	1360
1400	1652	1406	1567	20	9	1530
1500	1752	1506	1667	20	9	1530
1600	1852	1606	1767	22	10	1700
1700	1952	1706	1867	22	10	1700
1800	2052	1806	1967	24	11	1870
1900	2152	1906	2067	24	11	1870
2000	2252	2006	2167	26	12	2040

Note) When mounting the actuator using the body mounting reference plane, set the height of the mating surface or positioning pins to 3 mm minimum. (Recommended height 5 mm)

Motor Mounting Dimensions

Motor type	FA	FB	FC	FD	FE	FF	FG	FH	FJ
NZ	M4 x 0.7	8	46	30	3.5	27	—	—	2
NY	M3 x 0.5	8	45	30	3.5	27	—	—	4
NX	M4 x 0.7	8	46	30	3.5	27	—	—	2
NM1/NM2	3.4	—	31	22*	2.5*	27	6	21	4

* Dimensions after mounting a ring spacer (Refer to page 51.)

Refer to the "Motor Mounting" on page 51 for details about motor mounting and included parts.

Dimensions: Belt Drive

LEFB25U/Motor bottom mounting type

Positioning pin hole ^{Note)} (Option): Body bottom

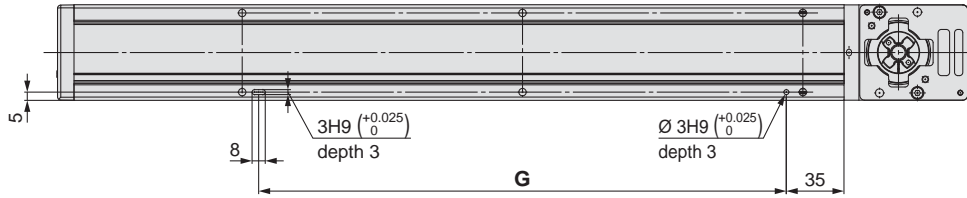

Note) When using the body bottom positioning pin holes, do not simultaneously use the housing B bottom pin hole.

With auto switch (Option)

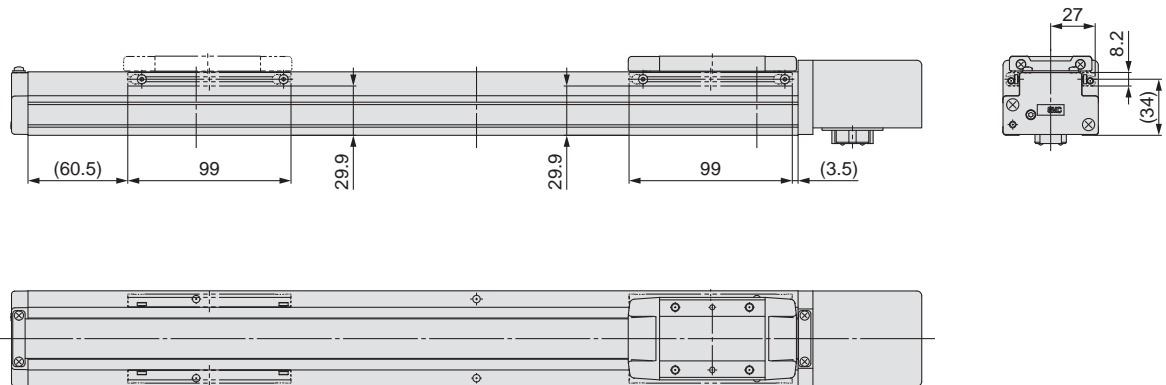

Dimensions [mm]

Stroke	G
300	320
400	490
500	490
600	660
700	660
800	830
900	1000
1000	1000
1100	1170
1200	1170
1300	1340
1400	1510
1500	1510
1600	1680
1700	1680
1800	1850
1900	1850
2000	2020

Refer to the "Motor Mounting" on page 51 for details about motor mounting and included parts.

Dimensions: Belt Drive

LEFB32/Motor top mounting type

Positioning pin hole ^{Note)} (Option): Body bottom

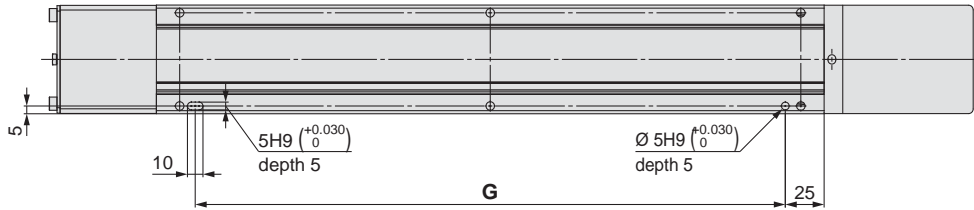

Note) When using the body bottom positioning pin holes, do not simultaneously use the housing B bottom pin hole.

With auto switch (Option)

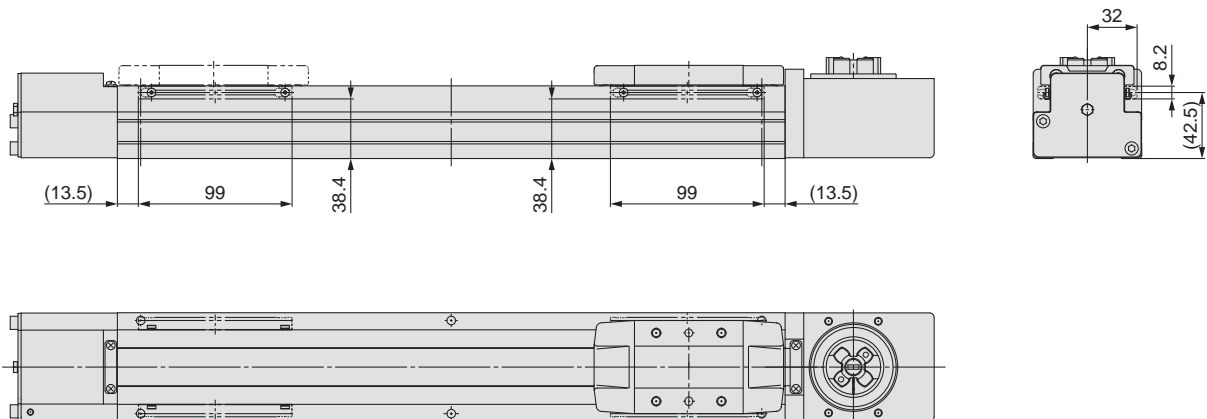

Dimensions [mm]

Stroke	G
300	380
400	380
500	580
600	580
700	780
800	780
900	980
1000	980
1100	1180
1200	1180
1300	1380
1400	1380
1500	1580
1600	1580
1700	1780
1800	1780
1900	1980
2000	1980
2500	2580

Series LEFB

Motorless Type

Refer to the "Motor Mounting" on page 51 for details of motor mounting and parts included.

Dimensions: Belt Drive

LEFB32U/Motor bottom mounting type

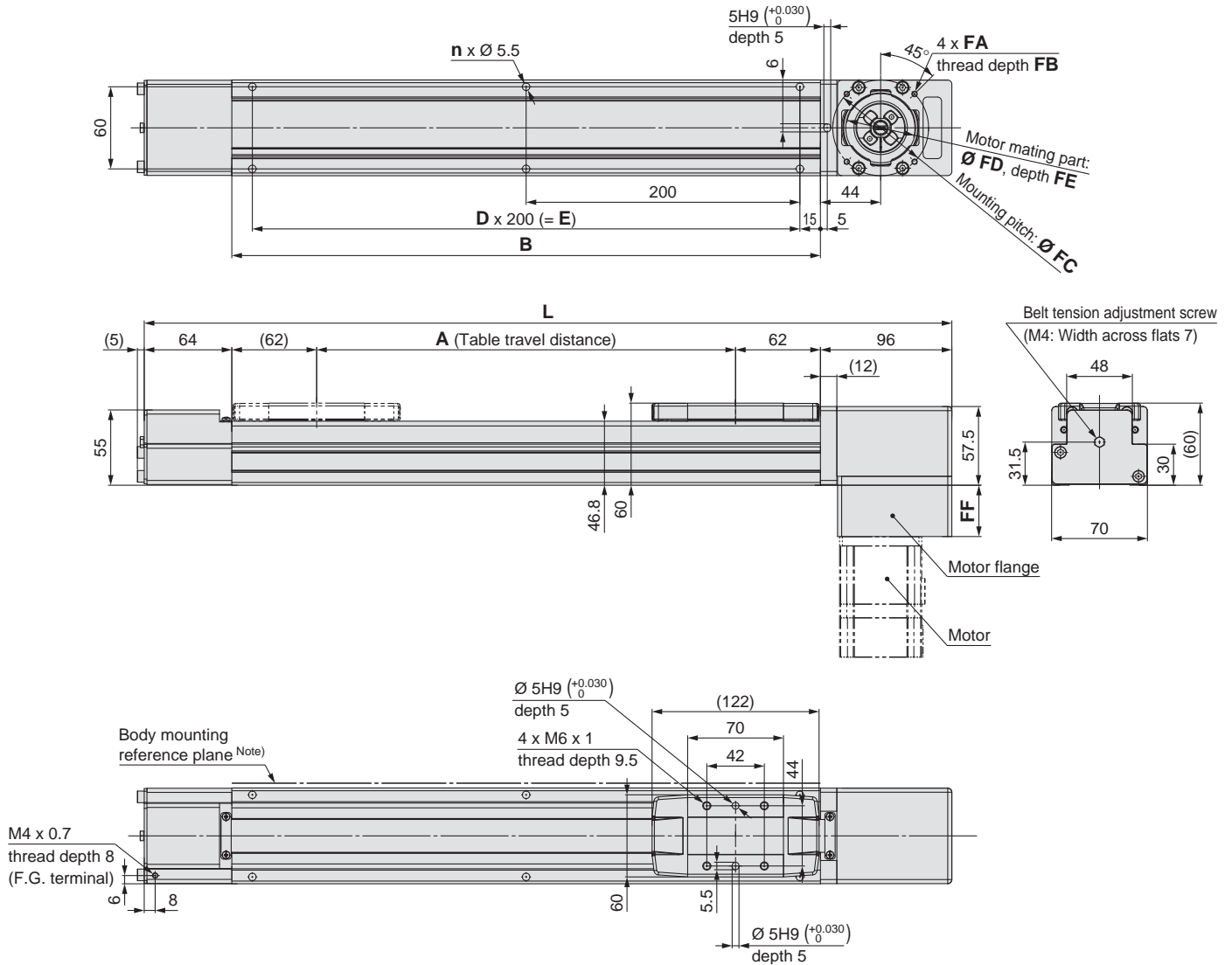

Note) When mounting the actuator using the body mounting reference plane, set the height of the mating surface or positioning pins to 3 mm minimum. (Recommended height 5 mm)

Dimensions

Stroke	L	A	B	n	D	E
300	590	306	430	6	2	400
400	690	406	530	6	2	400
500	790	506	630	8	3	600
600	890	606	730	8	3	600
700	990	706	830	10	4	800
800	1090	806	930	10	4	800
900	1190	906	1030	12	5	1000
1000	1290	1006	1130	12	5	1000
1100	1390	1106	1230	14	6	1200
1200	1490	1206	1330	14	6	1200
1300	1590	1306	1430	16	7	1400
1400	1690	1406	1530	16	7	1400
1500	1790	1506	1630	18	8	1600
1600	1890	1606	1730	18	8	1600
1700	1990	1706	1830	20	9	1800
1800	2090	1806	1930	20	9	1800
1900	2190	1906	2030	22	10	2000
2000	2290	2006	2130	22	10	2000
2500	2790	2506	2630	28	13	2600

Motor Mounting Dimensions

Motor type	FA	FB	FC	FD	FE	FF
NZ	M5 x 0.8	9	70	50	4	37.5
NY	M4 x 0.7	8	70	50	4	37.5
NX	M5 x 0.8	9	63	40*	4.5*	41.2
NW	M5 x 0.8	9	70	50	5	38.5
NV	M4 x 0.7	8	63	40*	4.5*	41.2
NU	M5 x 0.8	9	70	50	5	38.5
NT	M5 x 0.8	9	70	50	4	37.5
NM1	M4 x 0.7	8	□47.14	38.1*	4.5*	24.5
NM2	M4 x 0.7	8	□50	36*	4.5*	32

* Dimensions after mounting a ring spacer (Refer to page 51.)

Refer to the "Motor Mounting" on page 51 for details about motor mounting and included parts.

Dimensions: Belt Drive

LEFB32U/Motor bottom mounting type

Positioning pin hole ^{Note)} (Option): Body bottom

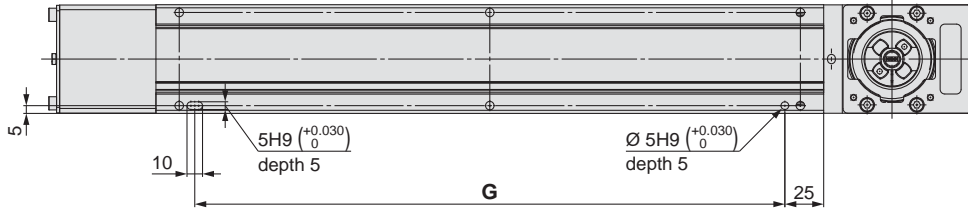

Note) When using the body bottom positioning pin holes, do not simultaneously use the housing B bottom pin hole.

With auto switch (Option)

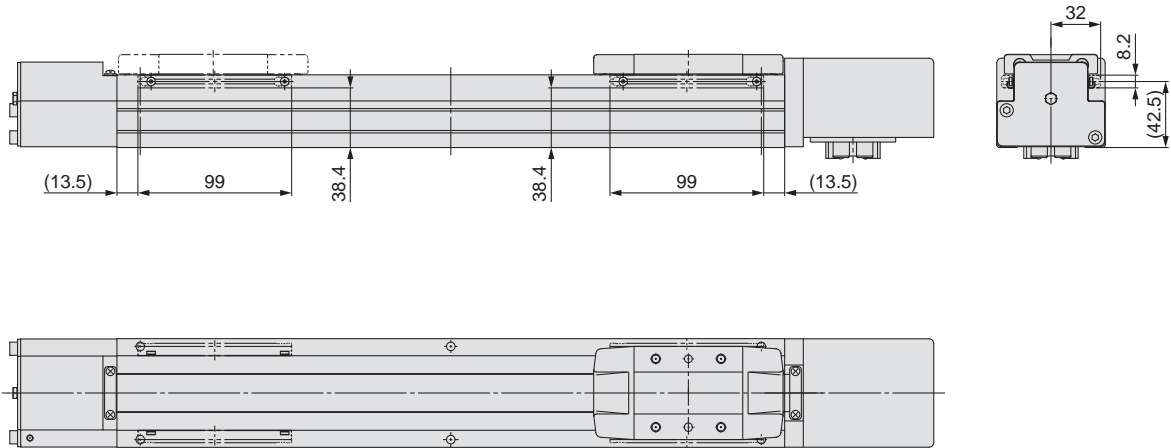

Dimensions [mm]

Stroke	G
300	380
400	380
500	580
600	580
700	780
800	780
900	980
1000	980
1100	1180
1200	1180
1300	1380
1400	1380
1500	1580
1600	1580
1700	1780
1800	1780
1900	1980
2000	1980
2500	2580

Series LEFB

Motorless Type

Refer to the "Motor Mounting" on page 51 for details of motor mounting and parts included.

Dimensions: Belt Drive

LEFB40/Motor top mounting type

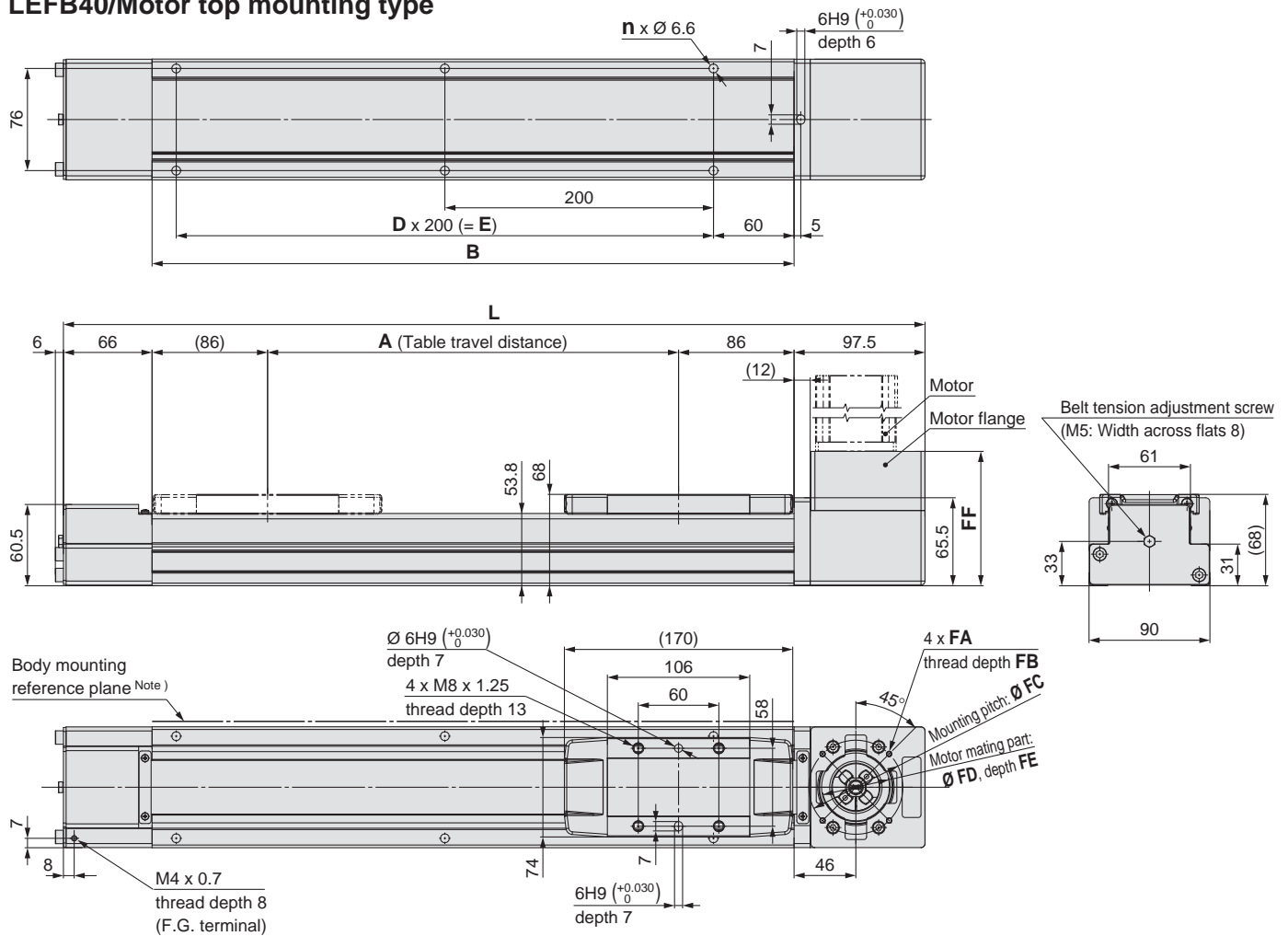

Note) When mounting the actuator using the body mounting reference plane, set the height of the mating surface or positioning pins to 3 mm minimum. (Recommended height 5 mm)

Dimensions

Stroke	L	A	B	n	D	E
300	641.5	306	478	6	2	400
400	741.5	406	578	6	2	400
500	841.5	506	678	8	3	600
600	941.5	606	778	8	3	600
700	1041.5	706	878	10	4	800
800	1141.5	806	978	10	4	800
900	1241.5	906	1078	12	5	1000
1000	1341.5	1006	1178	12	5	1000
1100	1441.5	1106	1278	14	6	1200
1200	1541.5	1206	1378	14	6	1200
1300	1641.5	1306	1478	16	7	1400
1400	1741.5	1406	1578	16	7	1400
1500	1841.5	1506	1678	18	8	1600
1600	1941.5	1606	1778	18	8	1600
1700	2041.5	1706	1878	20	9	1800
1800	2141.5	1806	1978	20	9	1800
1900	2241.5	1906	2078	22	10	2000
2000	2341.5	2006	2178	22	10	2000
2500	2841.5	2506	2678	28	13	2600
3000	3341.5	3006	3178	32	15	3000

Motor Mounting Dimensions

Motor type	FA	FB	FC	FD	FE	FF
NZ	M5 x 0.8	9	70	50	4	100
NY	M4 x 0.7	8	70	50	4	100
NX	M5 x 0.8	9	63	40*	4.5*	103.2
NW	M5 x 0.8	9	70	50	5	101
NV	M4 x 0.7	8	63	40	4.5*	103.2
NU	M5 x 0.8	9	70	50	5	101
NT	M5 x 0.8	9	70	50	4	100
NM1	M4 x 0.7	8	□47.14	38.1*	4.5*	87
NM2	M4 x 0.7	8	□50	36*	4.5*	94

* Dimensions after mounting a ring spacer (Refer to page 51.)

Refer to the "Motor Mounting" on page 51 for details about motor mounting and included parts.

Dimensions: Belt Drive

LEFB40/Motor top mounting type

Positioning pin hole ^{Note)} (Option): Body bottom

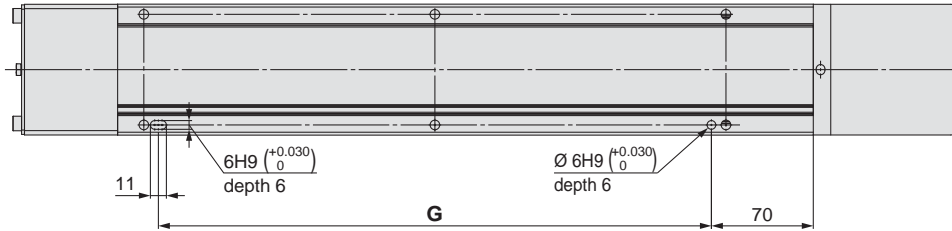

Note) When using the body bottom positioning pin holes, do not simultaneously use the housing B bottom pin hole.

With auto switch (Option)

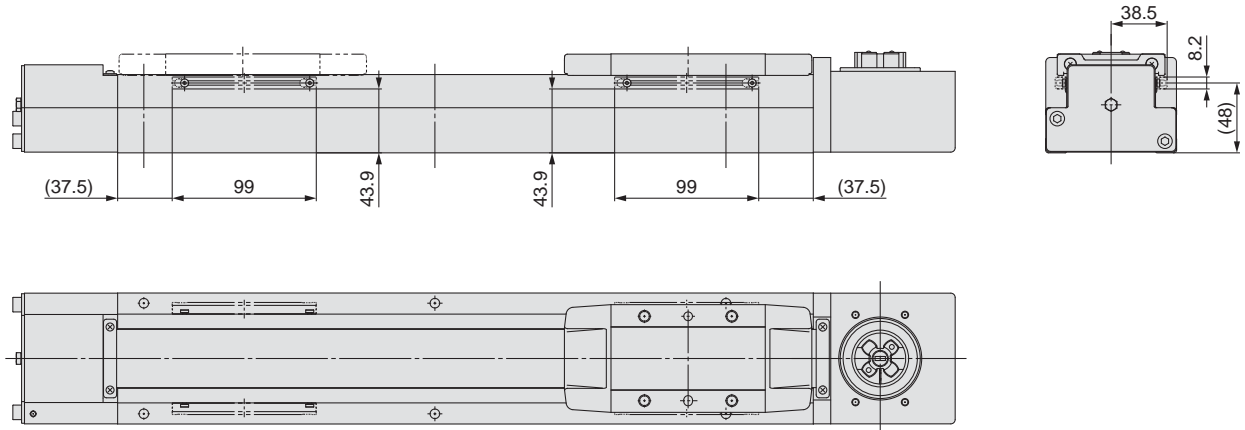

Dimensions [mm]

Stroke	G
300	380
400	380
500	580
600	580
700	780
800	780
900	980
1000	980
1100	1180
1200	1180
1300	1380
1400	1380
1500	1580
1600	1580
1700	1780
1800	1780
1900	1980
2000	1980
2500	2580
3000	2980

Series LEFB

Motorless Type

Refer to the "Motor Mounting" on page 51 for details of motor mounting and parts included.

Dimensions: Belt Drive

LEFB40U/Motor bottom mounting type

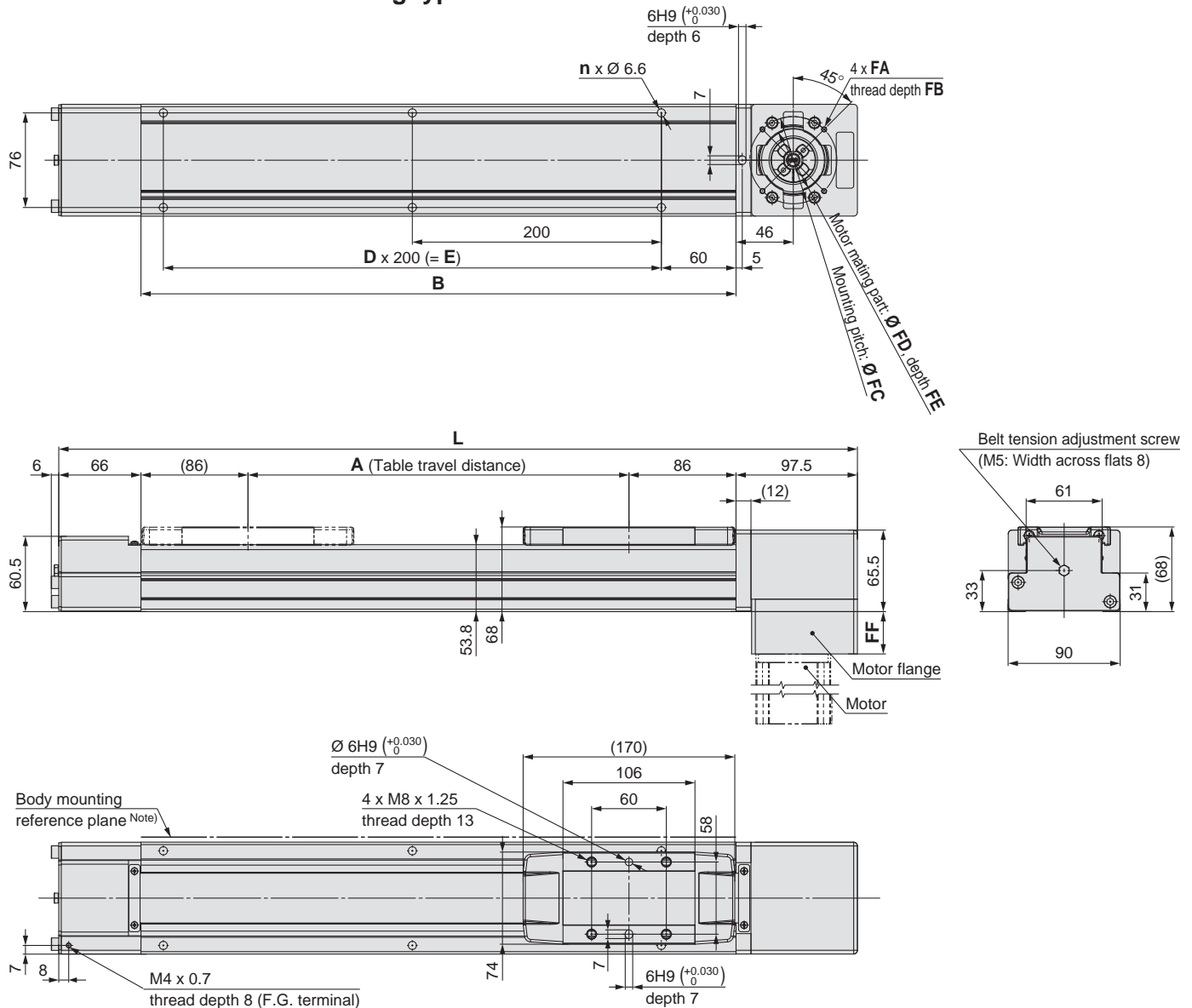

Dimensions

Stroke	L	A	B	n	D	E	[mm]
300	641.5	306	478	6	2	400	
400	741.5	406	578	6	2	400	
500	841.5	506	678	8	3	600	
600	941.5	606	778	8	3	600	
700	1041.5	706	878	10	4	800	
800	1141.5	806	978	10	4	800	
900	1241.5	906	1078	12	5	1000	
1000	1341.5	1006	1178	12	5	1000	
1100	1441.5	1106	1278	14	6	1200	
1200	1541.5	1206	1378	14	6	1200	
1300	1641.5	1306	1478	16	7	1400	
1400	1741.5	1406	1578	16	7	1400	
1500	1841.5	1506	1678	18	8	1600	
1600	1941.5	1606	1778	18	8	1600	
1700	2041.5	1706	1878	20	9	1800	
1800	2141.5	1806	1978	20	9	1800	
1900	2241.5	1906	2078	22	10	2000	
2000	2341.5	2006	2178	22	10	2000	
2500	2841.5	2506	2678	28	13	2600	
3000	3341.5	3006	3178	32	15	3000	

Note) When mounting the actuator using the body mounting reference plane, set the height of the mating surface or positioning pins to 3 mm minimum. (Recommended height 5 mm)

Motor Mounting Dimensions

Motor type	FA	FB	FC	FD	FE	FF	[mm]
NZ	M5 x 0.8	9	70	50	4	34	
NY	M4 x 0.7	8	70	50	4	34	
NX	M5 x 0.8	9	63	40*	4.5*	37.2	
NW	M5 x 0.8	9	70	50	5	35	
NV	M4 x 0.7	8	63	40*	4.5*	37.2	
NU	M5 x 0.8	9	70	50	5	35	
NT	M5 x 0.8	9	70	50	4	34	
NM1	M4 x 0.7	8	□47.14	38.1*	4.5*	21	
NM2	M4 x 0.7	8	□50	36*	4.5*	28	

* Dimensions after mounting a ring spacer (Refer to page 51.)

Refer to the "Motor Mounting" on page 51 for details about motor mounting and included parts.

Dimensions: Belt Drive

LEFB40U/Motor bottom mounting type

Positioning pin hole ^{Note)} (Option): Body bottom

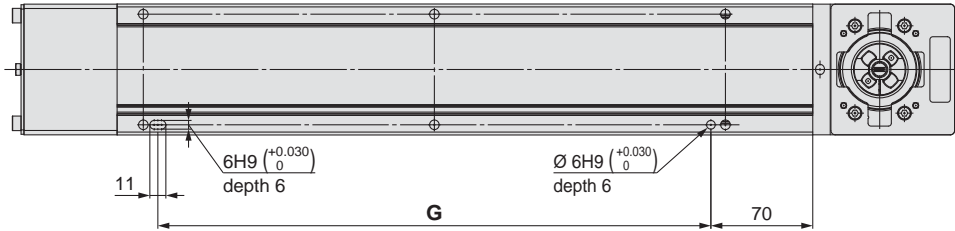

Note) When using the body bottom positioning pin holes, do not simultaneously use the housing B bottom pin hole.

With auto switch (Option)

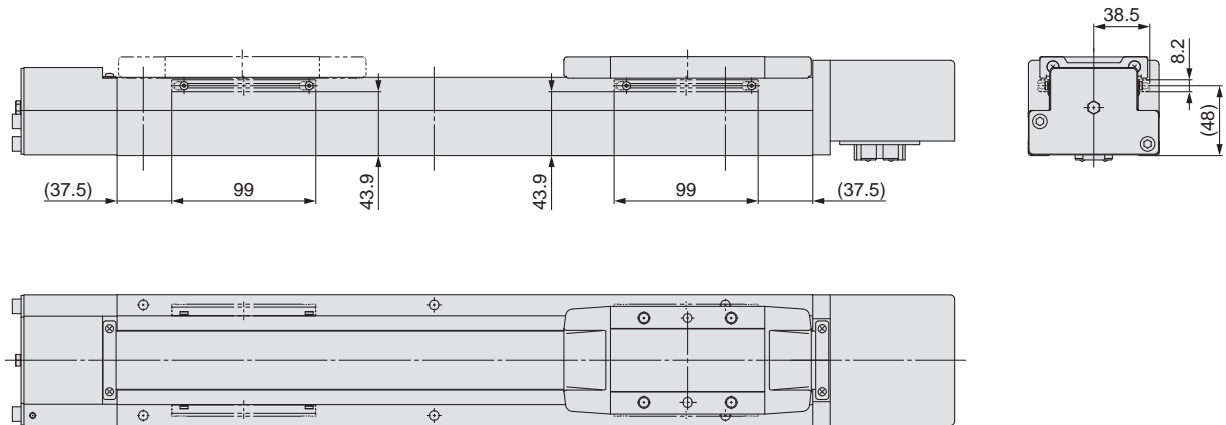

Dimensions [mm]

Stroke	G
300	380
400	380
500	580
600	580
700	780
800	780
900	980
1000	980
1100	1180
1200	1180
1300	1380
1400	1380
1500	1580
1600	1580
1700	1780
1800	1780
1900	1980
2000	1980
2500	2580
3000	2980

Series LEFB

Motorless Type

- When mounting a hub, remove any oil, dust, or dirt from the shaft and hub inside diameter.
- This product does not include the motor and motor mounting screws. (Provided by user)
The motor drive shaft shape should be of the plain round type, without a keyway; except for the NM1 motor option which requires a flat (D-cut).
- Take measures to prevent the motor mounting screws becoming loose.

Motor Mounting

Motor type: NZ, NY, NX, NW, NV, NU, NT, NM2

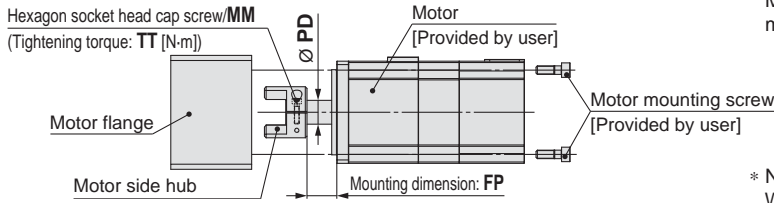

* Note for mounting a motor to the NM2 motor type
Motor mounting screws for the LEFB25 are fixed starting from the motor flange side. (Opposite of the drawing)

Motor type: NM1

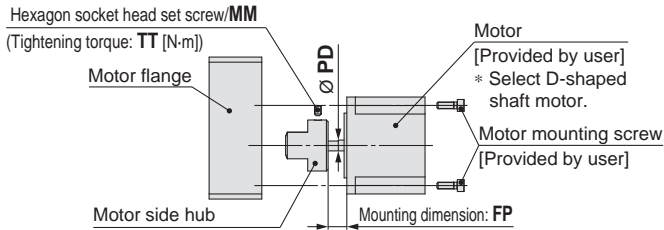

* Note for mounting a hub to the NM1 motor type
When mounting the hub to the motor, make sure to position the set screw perpendicular to the D-cut surface of the motor shaft. (Refer to the figure shown below)

* Motor mounting screws for the LEFB25 are fixed starting from the motor flange side. (Opposite of the drawing)

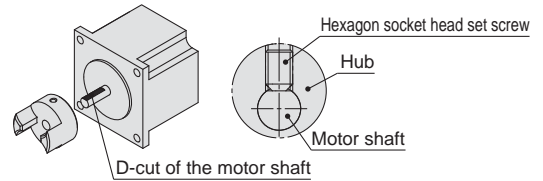

Motor Mounting Diagram

Motor type: NZ, NY, NW, NU, NT

Mounting procedure

- 1) Fix the motor (provided by user) and the motor hub with the "MM hexagon socket head cap screw."
- 2) Check the "motor hub position", and then insert it.
- 3) Fix the motor and the "motor flange" with the motor mounting screws (provided by user).

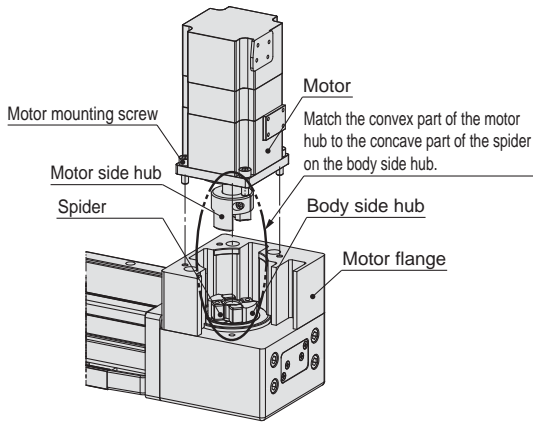

Motor type: NX, NV, NM1, NM2

Mounting procedure

- 1) Fix the motor (provided by user) and the "motor hub" with the "MM hexagon socket head cap screw (Motor type: NX, NM2)" or "MM hexagon socket head set screw (Motor type: NM1)."
- 2) Check the "motor hub position", and then insert it.
- 3) Mount the "ring spacer" to the motor.
- 4) Fix the motor and the "motor flange" with the motor mounting screws (provided by user).
- * For the LEFB25
- 4) Remove the "motor flange", which has been temporarily mounted, from the housing B, and secure the motor to the "motor flange" using the motor mounting screws (provided by user).
- 5) Tighten the "motor flange" to the "housing B" using motor flange fixing screws (included parts).

Match the convex part of the motor hub to the concave part of the spider on the body side hub.

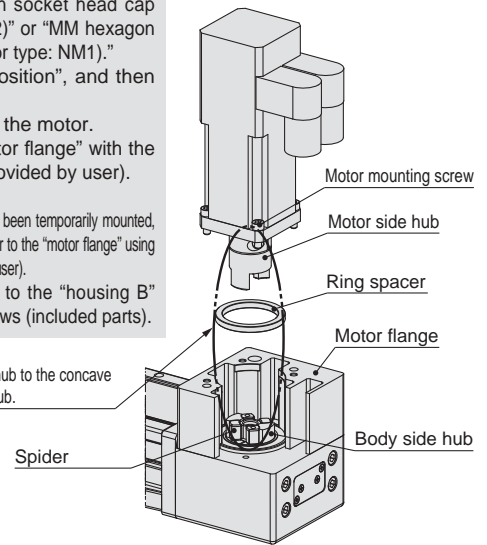

Size: 25 Hub Mounting Dimensions [mm]

Motor type	MM	TT	PD	FP
NZ	M2.5 x 10	1.00	8	11
NY	M2.5 x 10	1.00	8	11
NX	M2.5 x 10	1.00	8	5.5
NM1	M3 x 4	0.63	5	11
NM2	M2.5 x 10	1.00	6	11

Size: 32 Hub Mounting Dimensions [mm]

Motor type	MM	TT	PD	FP
NZ	M3 x 12	1.5	14	17.5
NY	M4 x 12	2.5	11	17.5
NX	M4 x 12	2.5	9	5.2
NW	M4 x 12	2.5	9	12.5
NV	M4 x 12	2.5	9	5.2
NU	M4 x 12	2.5	11	12.5
NT	M3 x 12	1.5	12	17.5
NM1	M4 x 5	1.5	6.35	4.5
NM2	M4 x 12	2.5	10	12

Size: 40 Hub Mounting Dimensions [mm]

Motor type	MM	TT	PD	FP
NZ	M3 x 12	1.5	14	17.5
NY	M3 x 12	1.5	14	17.5
NX	M4 x 12	2.5	9	5.2
NW	M4 x 12	2.5	9	13
NV	M4 x 12	2.5	9	5.2
NU	M4 x 12	2.5	11	13
NT	M3 x 12	1.5	12	17.5
NM1	M4 x 5	1.5	6.35	5
NM2	M4 x 12	2.5	10	12

Parts List

Size: 25

Description	Quantity				
	Motor type				
	NZ	NY	NX	NM1	NM2
Motor side hub	1	1	1	1	1
Hexagon socket head cap screw/set screw (for hub fixing)*	1	1	1	1	1
Hexagon socket head cap screw (for motor flange fixing)*	—	—	—	2	2
Ring spacer	—	—	—	1	1

* For screw sizes, refer to the hub mounting dimensions.

Size: 32, 40

Description	Quantity									
	Motor type									
	NZ	NY	NX	NW	NV	NU	NT	NM1	NM2	
Motor side hub	1	1	1	1	1	1	1	1	1	
Hexagon socket head cap screw/set screw (for hub fixing)*	1	1	1	1	1	1	1	1	1	
Ring spacer	—	—	1	—	1	—	—	1	1	

* For screw sizes, refer to the hub mounting dimensions.

Series LEFB

Motor Mounting Parts

Motor Flange Option

Using this option the motor can be replaced with the motor types shown below. (Except NM1)
Use the following part numbers to select a compatible motor flange option and place an order.

How to Order

LEFB-MF 25 - NZ

Belt drive • ① ②

① Size

25	For LEF□25
32	For LEF□32
40	For LEF□40

② Motor type

Symbol	Type	Symbol	Type
NZ	Mounting type Z	NV	Mounting type V
NY	Mounting type Y	NU	Mounting type U
NX	Mounting type X	NT	Mounting type T
NW	Mounting type W	NM2	Mounting type M2

* Select only NZ, NY, NX or NM2 for the LEFB-MF25.

Compatible Motors

Applicable motor model			Size/Motor type											
Manufacturer	Series	Type	25				32/40							
			NZ Mounting type Z	NY Mounting type Y	NX Mounting type X	NM2 Mounting type M2	NZ Mounting type Z	NY Mounting type Y	NX Mounting type X	NW Mounting type W	NV Mounting type V	NU Mounting type U	NT Mounting type T	NM2 Mounting type M2
Mitsubishi Electric Corporation	MELSERVO-JN	HF-KN	●	—	—	—	●	—	—	—	—	—	—	—
	MELSERVO-J3	HF-KP	●	—	—	—	●	—	—	—	—	—	—	—
	MELSERVO-J4	HG-KR	●	—	—	—	●	—	—	—	—	—	—	—
YASKAWA Electric Corporation	Σ-V	SGMJV	●	—	—	—	●	—	—	—	—	—	—	—
SANYO DENKI CO., LTD.	SANMOTION R	R2	●	—	—	—	●	—	—	—	—	—	—	—
OMRON Corporation	Sysmac G5	R88M-K	●	—	—	—	—	●	—	—	—	—	—	—
Panasonic Corporation	MINAS-A4	MSMD	—	●	—	—	—	●	—	—	—	—	—	—
	MINAS-A5	MSMD/MHMD	—	●	—	—	—	●	—	—	—	—	—	—
FANUC CORPORATION	βis	β	●	—	—	—	● (β1 only)	—	—	●	—	—	—	—
NIDEC SANKYO CORPORATION	S-FLAG	MA/MH/MM	●	—	—	—	●	—	—	—	—	—	—	—
KEYENCE CORPORATION	SV	SV-M/SV-B	●	—	—	—	●	—	—	—	—	—	—	—
FUJI ELECTRIC CO., LTD.	ALPHA5	GYS/GYB	●	—	—	—	●	—	—	—	—	—	—	—
	FALDIC-α	GYS	●	—	—	—	●	—	—	—	—	—	—	—
ORIENTAL MOTOR Co., Ltd.	AR/AZ	AR/AZ	—	—	—	●	—	—	—	—	—	—	—	●
Rockwell Automation, Inc. (Allen-Bradley)	MP-/VP-	MP/VP	—	—	—	—	—	—	●	—	—	—	—	—
	TL	TLY-A	●	—	—	—	—	—	—	—	—	—	●	—
Beckhoff Automation GmbH	AM	AM30	●	—	—	—	—	—	—	—	●	—	—	—
	AM	AM31	●	—	—	—	—	—	—	—	—	●	—	—
	AM	AM80/AM81	●	—	—	—	—	—	●	—	—	—	—	—
Siemens AG	1FK7	1FK7	—	—	●	—	—	—	●	—	—	—	—	—
	1FK2	1FK2	●	—	—	—	●	—	—	—	—	●	—	—
Delta Electronics, Inc.	ASDA-A2	ECMA	●	—	—	—	●	—	—	—	—	—	—	—

Note) When the LEF□25NM1□□ is purchased, it is not possible to change to other motor types.

Model Selection

LEFS

LEFB

LEJS

LEY

LEYG

Motor Mounting

Series LEFB

Dimensions: Motor Flange Option

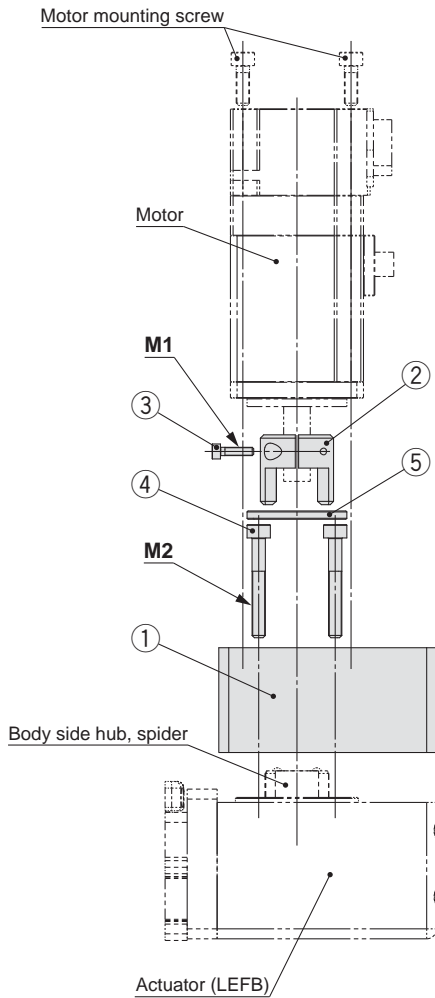

Component Parts

No.	Description	Quantity
1	Motor flange	1
2	Hub (Motor side)	1
3	Hexagon socket head cap screw (for hub fixing)	1
4	Hexagon socket head cap screw (for motor flange mounting)	2
5	Ring spacer (Only for NX, NV and NM2 of size 32, 40)	1

Motor flange details

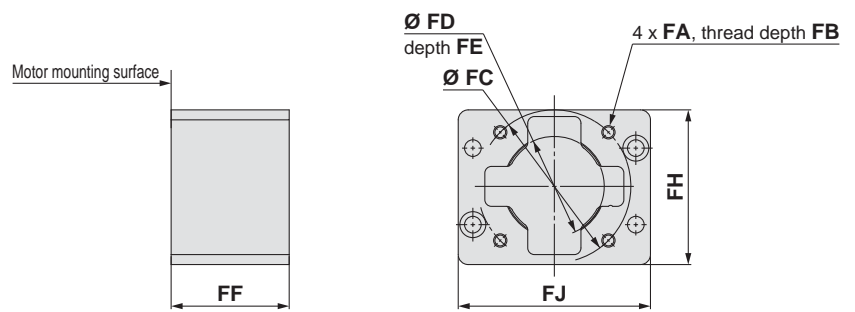

For NM2

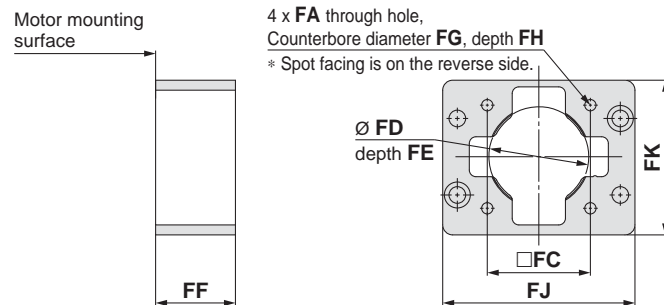

Dimensions

Size	Motor type	FA	FB	FC	FD	FE	FF	FG	FH	FJ	FK	M1	M2	PD
25	NZ/NX	M4 x 0.7	8	46	30	3.5	31.5	—	—	57.8	65.5	M2.5 x 10	M4 x 30	8
	NY	M3 x 0.5	8	45	30	3.5	31.5	—	—	57.8	65.5	M2.5 x 10	M4 x 30	8
	NM2	ø3.4	—	31	22*	2.5*	31.5	6	21	57.8	65.5	M2.5 x 10	M4 x 30	6
32	NZ	M5 x 0.8	9	70	50	4	44	—	—	69.8	83.5	M3 x 12	M5 x 45	14
	NY	M4 x 0.7	8	70	50	4	44	—	—	69.8	83.5	M4 x 12	M5 x 45	11
	NX	M5 x 0.8	9	63	50	5	47.7	—	—	69.8	83.5	M4 x 12	M5 x 45	9
	NW	M5 x 0.8	9	70	50	5	45	—	—	69.8	83.5	M4 x 12	M5 x 45	9
	NV	M4 x 0.7	8	63	50	5	47.7	—	—	69.8	83.5	M4 x 12	M5 x 45	9
	NU	M5 x 0.8	9	70	50	5	45	—	—	69.8	83.5	M4 x 12	M5 x 45	11
	NT	M5 x 0.8	9	70	50	4	44	—	—	69.8	83.5	M3 x 12	M5 x 45	12
	NM2	M4 x 0.7	8	50	36*	4.5*	38.5	—	—	69.8	83.5	M4 x 12	M5 x 25	10
40	NZ	M5 x 0.8	9	70	50	4	44	—	—	89.8	85	M3 x 12	M5 x 45	14
	NY	M4 x 0.7	8	70	50	4	44	—	—	89.8	85	M3 x 12	M5 x 45	14
	NX	M5 x 0.8	9	63	50	5	47.2	—	—	89.8	85	M4 x 12	M5 x 45	9
	NW	M5 x 0.8	9	70	50	5	45	—	—	89.8	85	M4 x 12	M5 x 45	9
	NV	M4 x 0.7	8	63	50	5	47.2	—	—	89.8	85	M4 x 12	M5 x 45	9
	NU	M5 x 0.8	9	70	50	5	45	—	—	89.8	85	M4 x 12	M5 x 45	11
	NT	M5 x 0.8	9	70	50	4	44	—	—	89.8	85	M3 x 12	M5 x 45	12
	NM2	M4 x 0.7	8	50	36*	4.5*	38	—	—	89.8	85	M4 x 12	M5 x 25	10

Series LEF

Auto Switch Mounting

Auto Switch Mounting Position

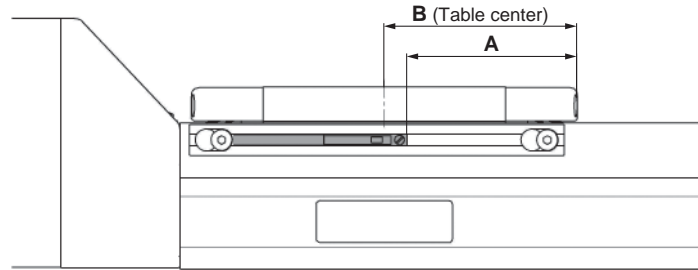

Model	Size	A	B	Operating range
LEFS LEFB	25	45	51	4.9
	32	55	61	3.9
	40	79	85	5.3

- Note 1) The applicable auto switch is D-M9 (N/P/B) (W) (M/L/Z)-1124.
- Note 2) The operating range is a guideline including hysteresis, not meant to be guaranteed. There may be large variations depending on the ambient environment.
- Note 3) Adjust the auto switch after confirming the operating conditions in the actual setting.

Auto Switch Mounting

Rotate the bolts for auto switch mounting bracket three to four times to loosen them (Removing them is not required), and slide and remove the auto switch mounting bracket. Then, insert a switch into the groove on the mounting bracket. As the mounting bolts for installing the product body interfere with the auto switch mounting bracket, mount the auto switch mounting bracket after installing the product body. After installing product body, tighten the bolts for the auto switch mounting bracket.

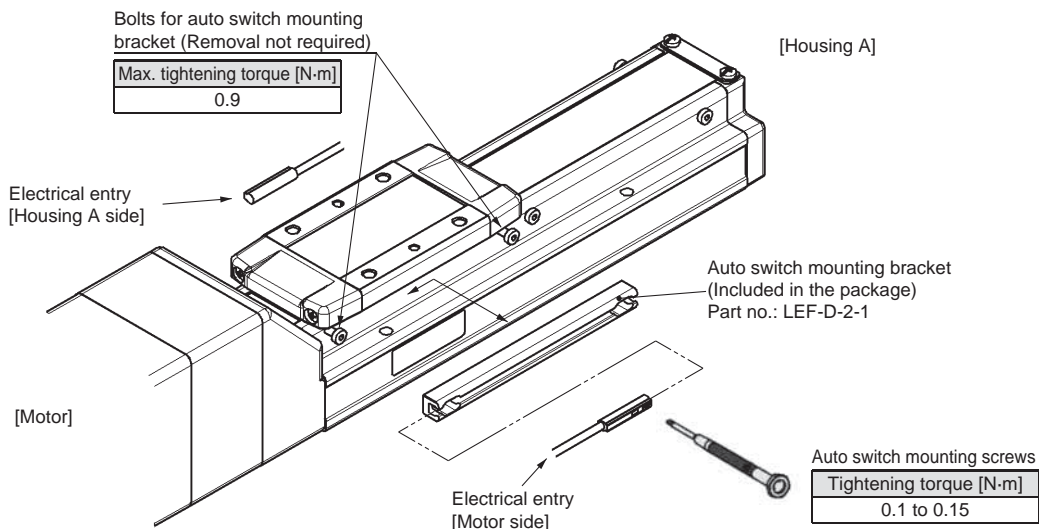

- Note 1) The applicable auto switch is D-M9 (N/P/B) (W) (M/L/Z)-1124.
- Note 2) The direction of the lead wire entry is specified. If it is mounted in the opposite direction, the auto switch may malfunction.
- Note 3) Tighten the auto switch mounting screws (provided together with the auto switch), using a precision screwdriver with a handle diameter of approximately 5 to 6 mm.
- Note 4) If more than two auto switch mounting brackets are required, please order them separately. All eight bolts for attaching the auto switch mounting bracket at the stroke end are tightened into the body when the product is shipped. For 50-mm stroke type, only four bolts are tightened on the motor side.

Solid State Auto Switch Direct Mounting Type

D-M9N-1124/D-M9P-1124/D-M9B-1124



Refer to SMC website for the details of the products conforming to the international standards.

Grommet

- 2-wire load current is reduced (2.5 to 40 mA).
- Using flexible cable as standard spec.



Caution

Precautions

Fix the auto switch with the existing screw installed on the auto switch body. The auto switch may be damaged if a screw other than the one supplied is used.

Auto Switch Specifications

PLC: Programmable Logic Controller

D-M9□, D-M9□V (With indicator light)			
Auto switch model	D-M9N-1124	D-M9P-1124	D-M9B-1124
Electrical entry direction	In-line		
Wiring type	3-wire		2-wire
Output type	NPN	PNP	—
Applicable load	IC circuit, Relay, PLC		24 VDC relay, PLC
Power supply voltage	5, 12, 24 VDC (4.5 to 28 V)		—
Current consumption	10 mA or less		—
Load voltage	28 VDC or less	—	24 VDC (10 to 28 VDC)
Load current	40 mA or less		2.5 to 40 mA
Internal voltage drop	0.8 V or less at 10 mA (2 V or less at 40 mA)		4 V or less
Leakage current	100 μA or less at 24 VDC		0.8 mA or less
Indicator light	Red LED illuminates when turned ON.		
Standard	CE marking, RoHS		

Oilproof Heavy-duty Lead Wire Specifications

Auto switch model		D-M9N-1124	D-M9P-1124	D-M9B-1124
Sheath	Outside diameter [mm]	2.6		
Insulator	Number of cores	3 cores (Brown/Blue/Black)		2 cores (Brown/Blue)
	Outside diameter [mm]	0.88		
Conductor	Effective area [mm ²]	0.15		
	Strand diameter [mm]	0.05		
Minimum bending radius [mm] (Reference values)		17		

Note 1) Refer to Auto Switch Guide for solid state auto switch common specifications.
Note 2) Refer to Auto Switch Guide for lead wire lengths.

Weight

(g)

Auto switch model		D-M9N-1124	D-M9P-1124	D-M9B-1124
Lead wire length	0.5 m (—)	8	—	7
	1 m (M)	14	—	13
	3 m (L)	41	—	38
	5 m (Z)	68	—	63

Dimensions

(mm)

D-M9□-1124

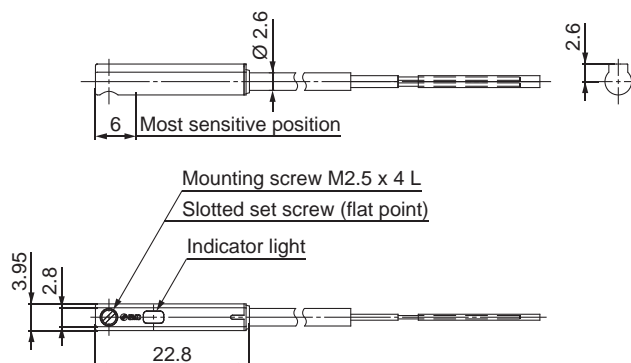

2-Color Indicator Solid State Auto Switch Direct Mounting Type

D-M9NW-1124/D-M9PW-1124/D-M9BW-1124



Refer to SMC website for the details of the products conforming to the international standards.

Grommet

- 2-wire load current is reduced (2.5 to 40 mA).
- Using flexible cable as standard spec.
- The proper operating range can be determined by the color of the light. (Red → Green ← Red)



Caution

Precautions

Fix the auto switch with the existing screw installed on the auto switch body. The auto switch may be damaged if a screw other than the one supplied is used.

Auto Switch Specifications

PLC: Programmable Logic Controller

D-M9□W, D-M9□WV (With indicator light)			
Auto switch model	D-M9NW-1124	D-M9PW-1124	D-M9BW-1124
Electrical entry direction	In-line		
Wiring type	3-wire		2-wire
Output type	NPN	PNP	—
Applicable load	IC circuit, Relay, PLC		24 VDC relay, PLC
Power supply voltage	5, 12, 24 VDC (4.5 to 28 V)		—
Current consumption	10 mA or less		—
Load voltage	28 VDC or less	—	24 VDC (10 to 28 VDC)
Load current	40 mA or less		2.5 to 40 mA
Internal voltage drop	0.8 V or less at 10 mA (2 V or less at 40 mA)		4 V or less
Leakage current	100 μA or less at 24 VDC		0.8 mA or less
Indicator light	Operating range Red LED illuminates. Proper operating range Green LED illuminates.		
Standard	CE marking, RoHS		

Oilproof Flexible Heavy-duty Lead Wire Specifications

Auto switch model		D-M9NW-1124	D-M9PW-1124	D-M9BW-1124
Sheath	Outside diameter [mm]	2.6		
Insulator	Number of cores	3 cores (Brown/Blue/Black)		2 cores (Brown/Blue)
	Outside diameter [mm]	0.88		
Conductor	Effective area [mm ²]	0.15		
	Strand diameter [mm]	0.05		
Minimum bending radius [mm] (Reference values)		17		

Note 1) Refer to Auto Switch Guide for solid state auto switch common specifications.

Note 2) Refer to Auto Switch Guide for lead wire lengths.

Weight

(g)

Auto switch model		D-M9NW-1124	D-M9PW-1124	D-M9BW-1124
Lead wire length	0.5 m (—)	8	7	7
	1 m (M)	14	13	13
	3 m (L)	41	38	38
	5 m (Z)	68	63	63

Dimensions

(mm)

D-M9□W-1124

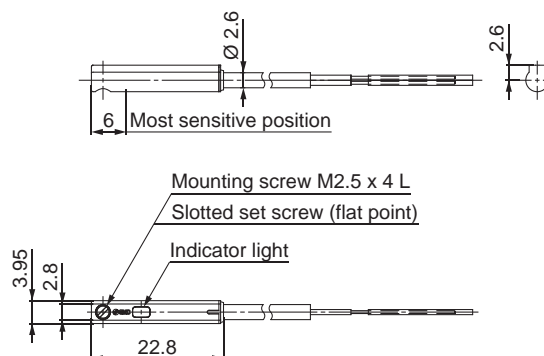



Series LEF Electric Actuator Specific Product Precautions 1

Be sure to read this before handling. Refer to the back cover for Safety Instructions. For Electric Actuator Precautions, refer to “Handling Precautions for SMC Products” and the Operation Manual on the SMC website, <http://www.smc.eu>

Design

⚠ Caution

1. Do not apply a load in excess of the specification limits.

Select a suitable actuator by work load and allowable moment. If the product is used outside of the specification limits, the eccentric load applied to the guide will be excessive and have adverse effects such as creating play on the guide, degrading accuracy and shortening the life of the product.

2. Do not use the product in applications where excessive external force or impact force is applied to it.

This can cause a failure.

Selection

⚠ Warning

1. Do not increase the speed in excess of the specification limits.

Select a suitable actuator by the relationship of the allowable work load and speed, and the allowable speed of each stroke. If the product is used outside of the specification limits, it will have adverse effects such as creating noise, degrading accuracy and shortening the life of the product.

2. Do not use the product in applications where excessive external force or impact force is applied to it.

This can cause a failure.

3. When the product repeatedly cycles with partial strokes (see the table below), operate it at a full stroke at least once every dozens of cycles.

Otherwise, the lubrication can run out.

Model	Partial stroke
LEF□25	65 mm or less
LEF□32	70 mm or less
LEF□40	105 mm or less

4. When external force is applied to the table, it is necessary to add external force to the work load as the total carried load for the sizing.

When a cable duct or flexible moving tube is attached to the actuator, the sliding resistance of the table increases and may lead to operational failure of the product.

Handling

⚠ Caution

1. Do not allow the table to hit the end of stroke.

When the driver parameters, origin or programs are set incorrectly, the table may collide against the stroke end of the actuator during operation. Check these points before use.

If the table collides against the stroke end of the actuator, the guide, ball screw, belt or internal stopper can be broken. This may lead to abnormal operation.

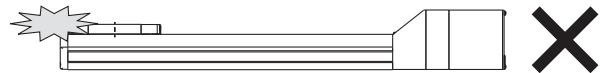

Handle the actuator with care when it is used in the vertical direction as the workpiece will fall freely due to its own weight.

2. The actual speed of this actuator is affected by the work load and stroke.

Check the specifications with reference to the model selection section of the catalogue.

3. Do not apply a load, impact or resistance in addition to the transferred load during return to origin.

4. Do not dent, scratch or cause other damage to the body and table mounting surfaces.

This may cause unevenness in the mounting surface, play in the guide or an increase in the sliding resistance.

5. Do not apply strong impact or an excessive moment while mounting a workpiece.

If an external force above the allowable moment is applied, it may cause play in the guide or an increase in the sliding resistance.

6. The flatness of mounting surface should be within 0.1 mm/500 mm.

Unevenness of a workpiece or base mounted on the body of the product may cause play in the guide and an increase in the sliding resistance.

7. Do not hit the table with the workpiece in the positioning operation and positioning range.

8. Grease is applied to the dust seal band for sliding. When wiping off the grease to remove foreign matter etc., be sure to apply it again.

9. For bottom mounting, the dust seal band may be deflected.



Series LEF Electric Actuator Specific Product Precautions 2

Be sure to read this before handling. Refer to the back cover for Safety Instructions. For Electric Actuator Precautions, refer to "Handling Precautions for SMC Products" and the Operation Manual on the SMC website, <http://www.smc.eu>

Handling

⚠ Caution

10. When mounting the product, use screws with adequate length and tighten them with adequate torque.

Tightening the screws with a higher torque than recommended may cause a malfunction, whilst tightening with a lower torque can cause the displacement of the mounting position or in extreme conditions the actuator could become detached from its mounting position.

Body fixed

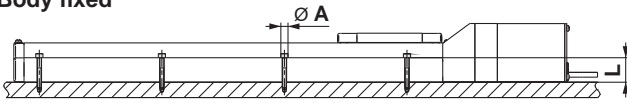

Model	Screw size	Max. tightening torque [N·m]	Ø A [mm]	L [mm]
LEF□25	M4	1.5	4.5	24
LEF□32	M5	3.0	5.5	30
LEF□40	M6	5.2	6.6	31

Body mounting

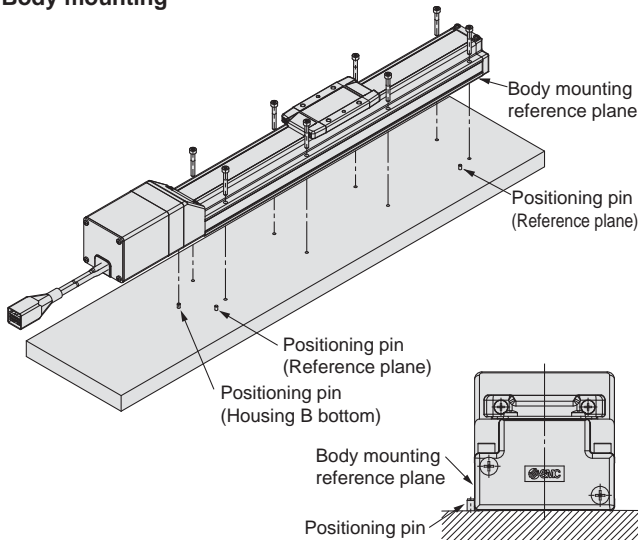

The parallelism of travel is with reference to the body mounting reference plane. If an accurate parallelism of travel is required, set the reference plane against positioning pins etc.

Workpiece fixed

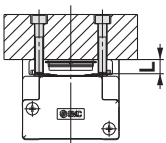

Model	Screw size	Max. tightening torque [N·m]	L (Max. screw-in depth) [mm]
LEF□25	M5 x 0.8	3.0	8
LEF□32	M6 x 1	5.2	9
LEF□40	M8 x 1.25	12.5	13

To prevent the workpiece retaining screws from interfering with the body, use screws that are at least 0.5 mm shorter than the maximum screw-in depth. If long screws are used, they can touch the body and cause a malfunction.

11. Do not operate with the table fixed and the actuator body moving.

12. A belt drive actuator cannot be used for vertical applications.

13. Check the specifications for the minimum speed of each actuator.

Otherwise, unexpected malfunctions, such as knocking, may occur.

14. In the case of the belt drive actuator, vibration may occur during operation at speeds within the actuator specifications, which could be caused by the operating conditions. Change the speed setting to a speed that does not cause vibration.

Maintenance

⚠ Warning

Maintenance frequency

Perform maintenance according to the table below.

Frequency	Appearance check	Internal check
Inspection before daily operation	○	—
Inspection every 6 months/1000 km/5 million cycles*	○	○

* Select whichever comes first.

• Items for visual appearance check

1. Loose set screws, Abnormal dirt
2. Check of flaw and cable joint
3. Vibration, Noise

• Items for internal check

1. Lubricant condition on moving parts.
2. Loose or mechanical play in fixed parts or fixing screws.

High Rigidity Slider Type

Ball Screw Drive Series LEJS



Model Selection

LEFS

LEFB

LEJS

LEY

LEYG

Motor Mounting

Motorless Type Electric Actuator/High Rigidity Slider Type Ball Screw Drive/Series LEJS Model Selection



Selection Procedure



Selection Example

Operating conditions

- Work piece weight: 60 [kg]
 - Speed: 300 [mm/s]
 - Acceleration/Deceleration: 3000 [mm/s²]
 - Stroke: 300 [mm]
 - Mounting orientation: Horizontal
 - External force: 10 [N]
- Workpiece mounting condition:
-

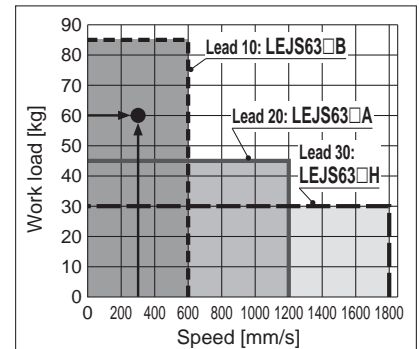

<Speed-Work Load Graph>
(LEJS63)

Step 1 Check the speed-work load.

Select a model based on the workpiece mass and speed, within the range of the actuator specifications while referring to the "Speed-Work Load Graph (Guide)" on page 46.

Selection example) The LEJS63□B-300 is provisionally selected based on the graph on the right.

* Refer to the motor manufacturers catalogue for details of the regeneration resistance.

Step 2 Check the cycle time.

Refer to method 1 for a rough estimate, and method 2 for a more precise value.

Method 1: Refer to the cycle time graph. (Page 63)

The graph is based on the maximum speed of each size.

Method 2: Calculation

Cycle time T can be found from the following equation.

$$T = T1 + T2 + T3 + T4 \text{ [s]}$$

- T1 and T3 can be found by the following equation.

$$T1 = V/a1 \text{ [s]} \quad T3 = V/a2 \text{ [s]}$$

The acceleration and deceleration values have upper limits depending on the workpiece mass and the duty ratio.

Confirm that they do not exceed the upper limit, by referring to the "Work load-Acceleration/Deceleration Graph (Guide)" on pages 64 and 65.

For the ball screw type, there is an upper limit of the speed depending on the stroke. Confirm that it does not exceed the upper limit, by referring to the specifications on page 73.

- T2 can be found from the following equation.

$$T2 = \frac{L - 0.5 \cdot V \cdot (T1 + T3)}{V} \text{ [s]}$$

- T4 varies depending on the motor type and load. The value below is recommended.

$$T4 = 0.05 \text{ [s]}$$

* The conditions for the settling time vary depending on the motor or driver to be used.

Calculation example)

T1 to T4 can be calculated as follows.

$$T1 = V/a1 = 300/3000 = 0.1 \text{ [s]}$$

$$T3 = V/a2 = 300/3000 = 0.1 \text{ [s]}$$

$$T2 = \frac{L - 0.5 \cdot V \cdot (T1 + T3)}{V} = \frac{300 - 0.5 \cdot 300 \cdot (0.1 + 0.1)}{300} = 0.90 \text{ [s]}$$

$$T4 = 0.05 \text{ [s]}$$

Therefore, the cycle time can be calculated as follows.

$$T = T1 + T2 + T3 + T4 = 0.1 + 0.90 + 0.1 + 0.05 = 1.15 \text{ [s]}$$

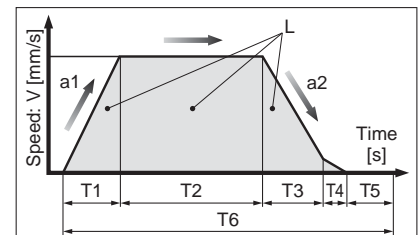

L : Stroke [mm]
V : Speed [mm/s]
a1: Acceleration [mm/s²]
a2: Deceleration [mm/s²]

- T1: Acceleration time [s]
Time until the set speed is reached
- T2: Constant speed time [s]
Time when the actuator is operating at a constant speed
- T3: Deceleration time [s]
Time from the constant speed operation until movement stops
- T4: Settling time [s]
Time until positioning is completed
- T5: Resting time [s]
Time the actuator is not moving
- T6: Total time [s]
Total time from T1 to T5

Duty ratio: Ratio of T to T6
 $T \div T6 \times 100$

Step 3 Check the allowable moment.

Refer to the "Dynamic Allowable Moment" graphs on pages 66 and 67.

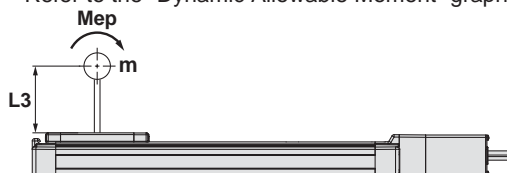

Selection example) Select the LEJS63□B-300 from the graph on the right side.

Confirm that the external force is within the allowable external force (20 [N]).

(The external force is the resistance due to cable duct, flexible trunking or air tubing.)

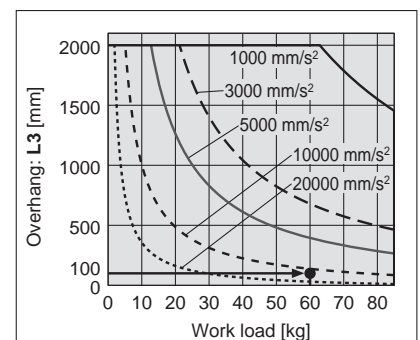

<Dynamic Allowable Moment>
(LEJS63)

* The values given below are within the actuator body specification range, with a standard motor mounted and should not be exceeded.
 * The allowable speed is restricted depending on the stroke. Select it by referring to the "Allowable Stroke Speed."

Speed-Work Load Graph (Guide)

LEJS40/Ball Screw Drive

Horizontal

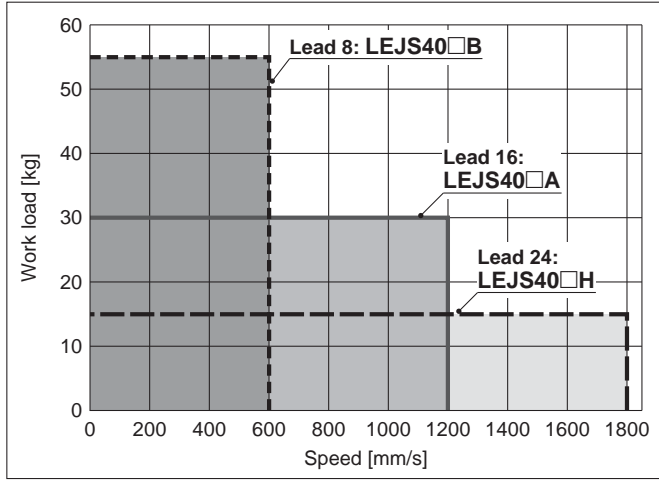

Vertical

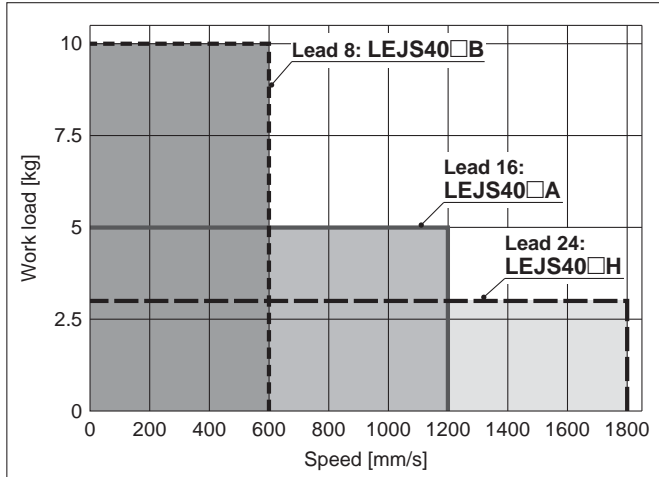

LEJS63/Ball Screw Drive

Horizontal

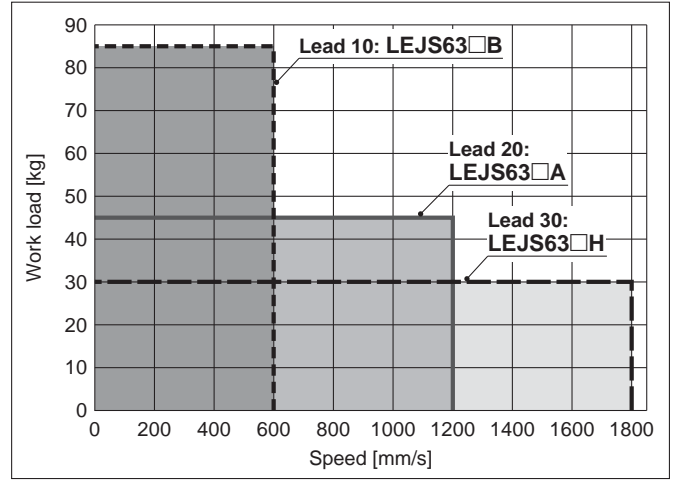

Vertical

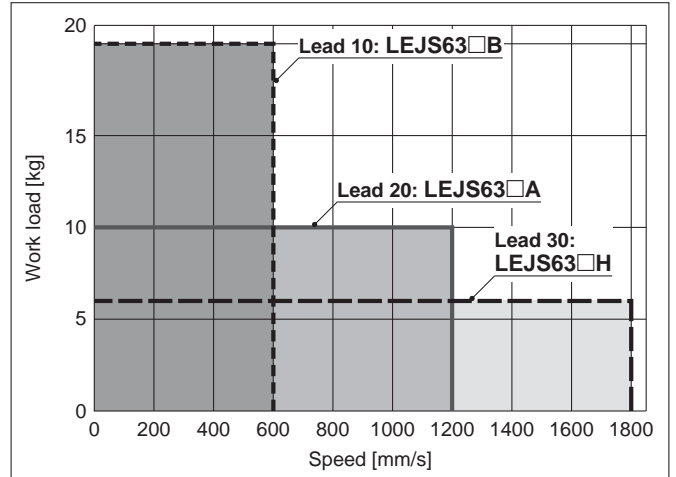

Allowable Stroke Speed

Model	Motor	Lead		Stroke [mm]														
		Symbol	[mm]	Up to 200	Up to 300	Up to 400	Up to 500	Up to 600	Up to 700	Up to 800	Up to 900	Up to 1000	Up to 1100	Up to 1200	Up to 1300	Up to 1400	Up to 1500	
LEJS40	100 W equivalent	H	24			1800			1580	1170	910	720	580	480	410	—	—	—
		A	16			1200			1050	780	600	480	390	320	270	—	—	—
		B	8			600			520	390	300	240	190	160	130	—	—	—
		(Motor rotation speed)		(4500 rpm)			(3938 rpm)			(2925 rpm)	(2250 rpm)	(1800 rpm)	(1463 rpm)	(1200 rpm)	(1013 rpm)	—	—	—
LEJS63	200 W equivalent	H	30	—			1800			1390	1110	900	750	630	540	470	410	
		A	20	—			1200			930	740	600	500	420	360	310	270	
		B	10	—			600			460	370	300	250	210	180	150	130	
		(Motor rotation speed)		—			(3600 rpm)			(2790 rpm)			(2220 rpm)	(1800 rpm)	(1500 rpm)	(1260 rpm)	(1080 rpm)	(930 rpm)

Model Selection

LEFS

LEFB

LEJS

LEY

LEYG

Motor Mounting

Series LEJS

Motorless Type

Cycle Time Graph (Guide)

LEJS40/Ball Screw Drive

LEJS40□H

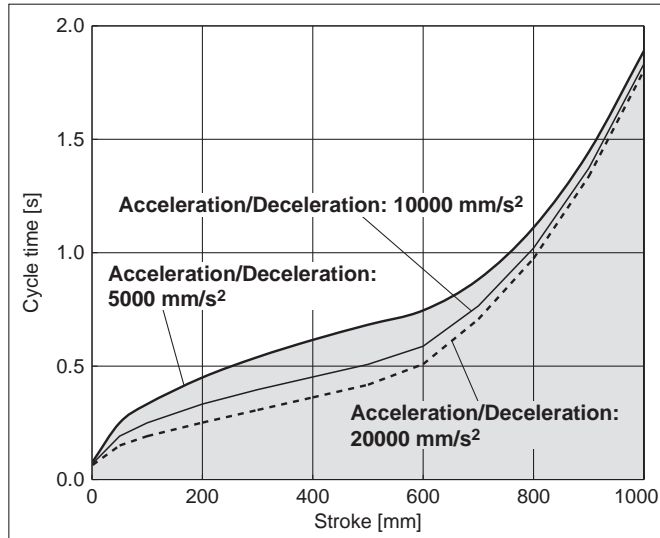

LEJS40□A

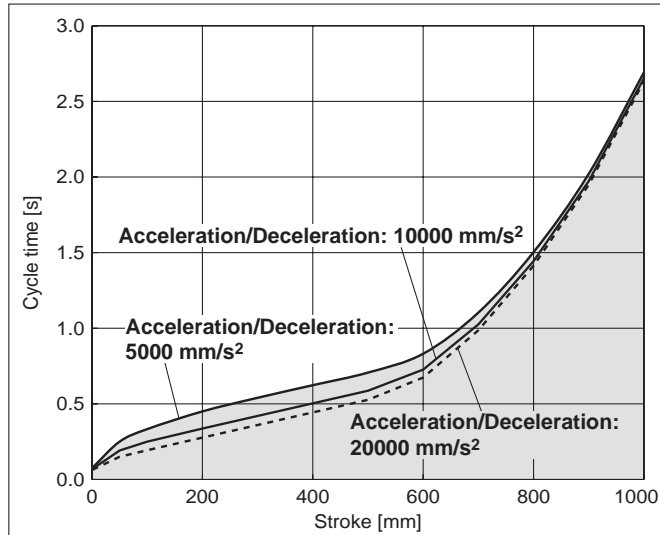

LEJS40□B

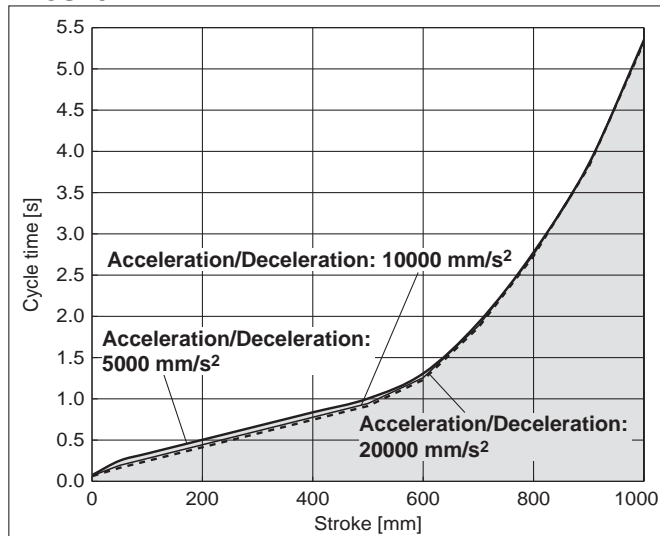

LEJS63/Ball Screw Drive

LEJS63□H

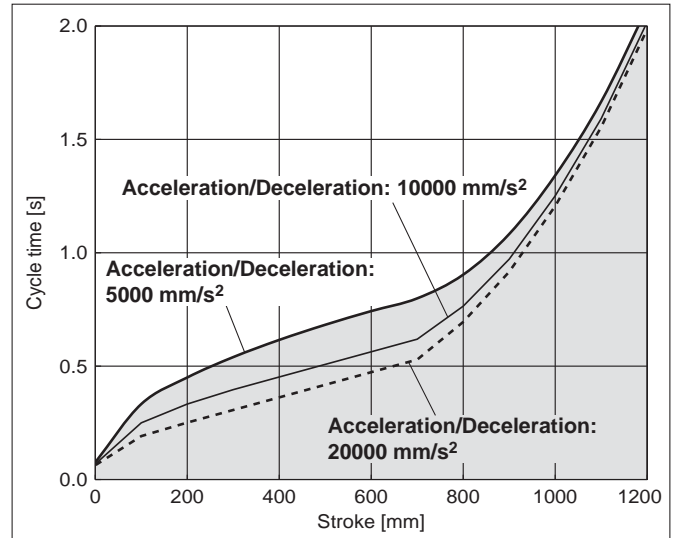

LEJS63□A

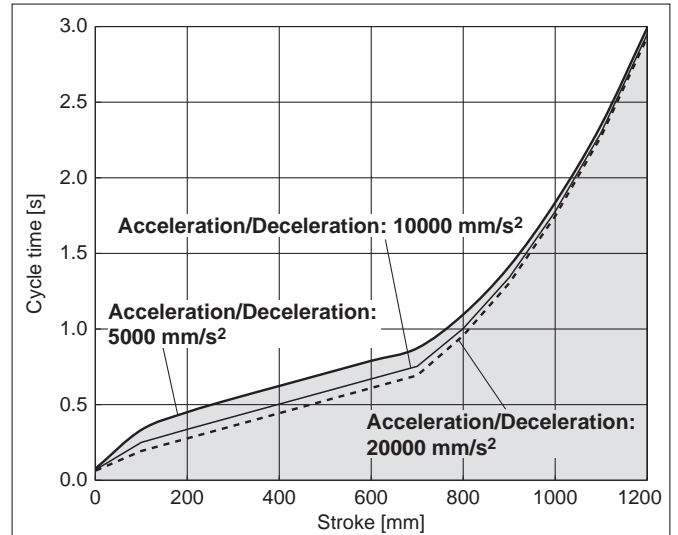

LEJS63□B

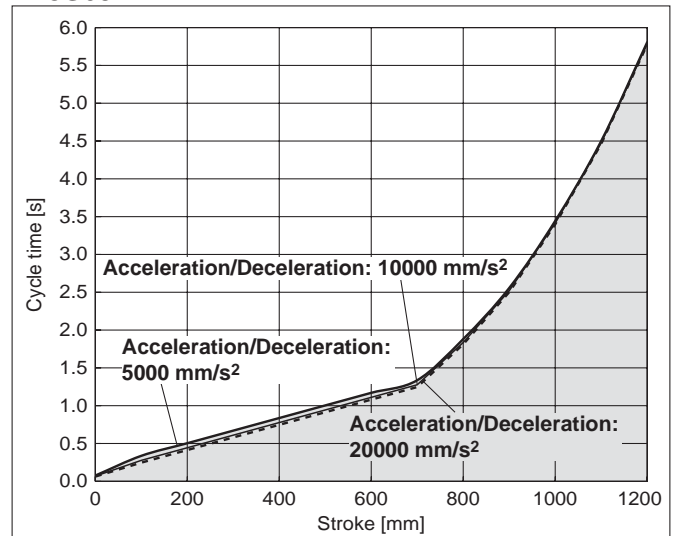

* These graphs show the cycle time for each acceleration/deceleration.
 * These graphs show the cycle time for each stroke at the maximum speed.

Work Load–Acceleration/Deceleration Graph (Guide)

LEJS40/Ball Screw Drive: Horizontal

LEJS40□H

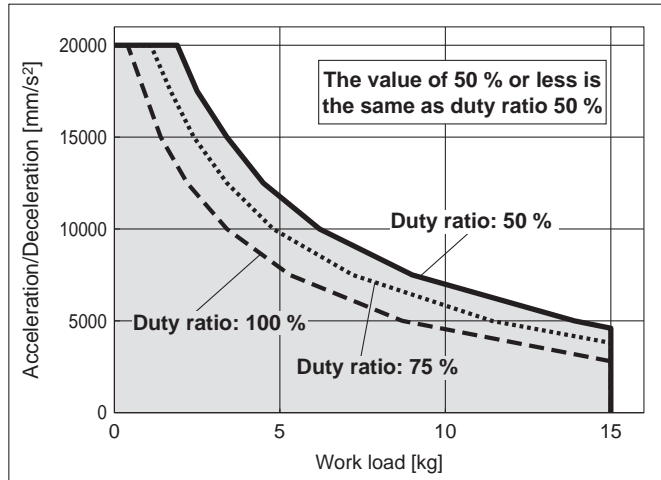

LEJS63/Ball Screw Drive: Horizontal

LEJS63□H

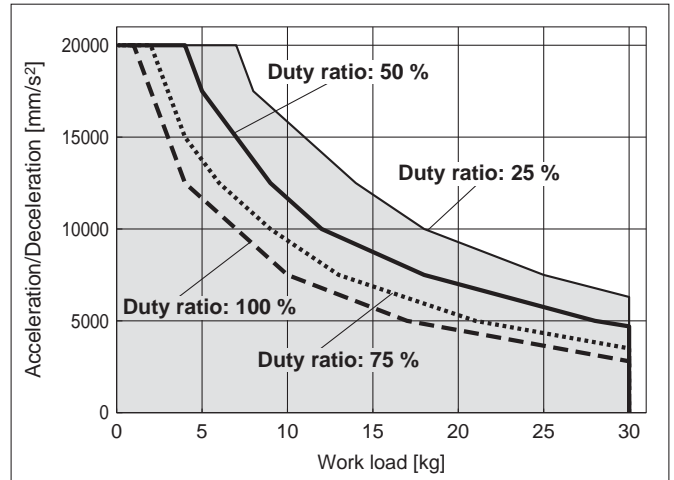

LEJS40□A

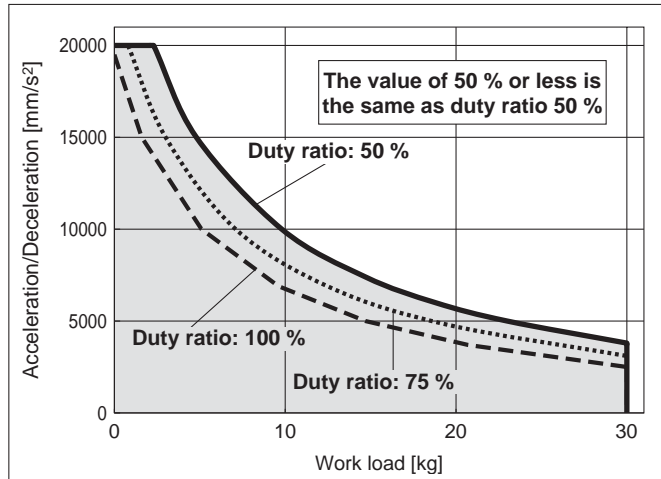

LEJS63□A

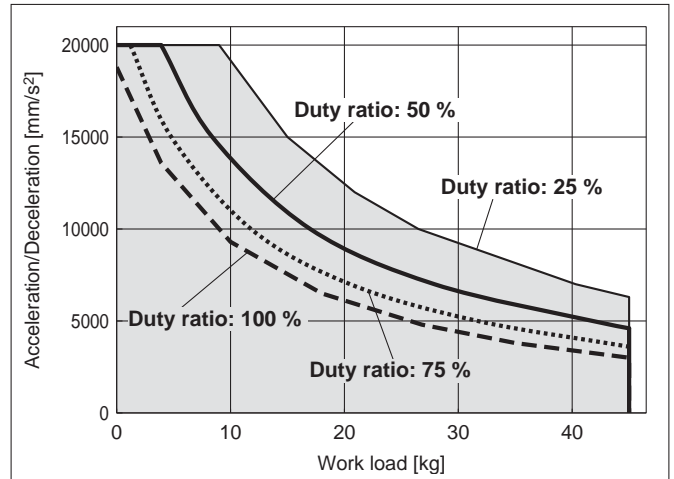

LEJS40□B

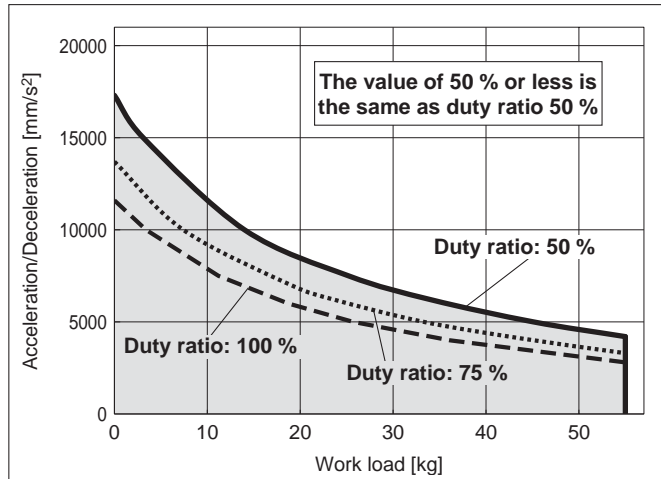

LEJS63□B

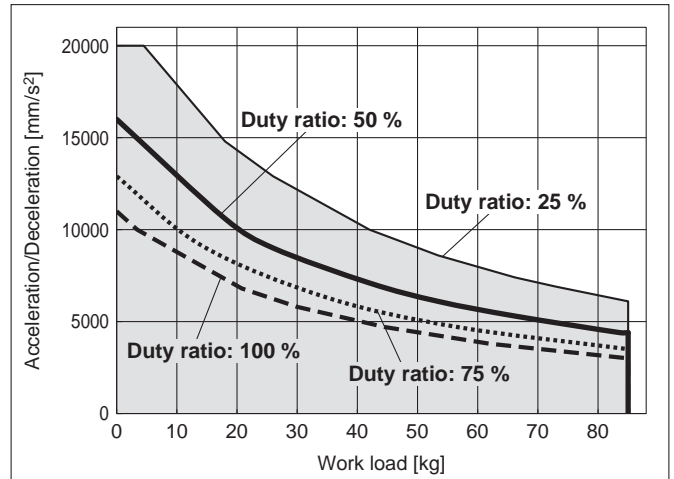

These graphs are examples of when the standard motor is mounted.
Determine the duty ratio after taking into account the load factor of the motor or driver to be used.

Series LEJS

Motorless Type

Work Load–Acceleration/Deceleration Graph (Guide)

LEJS40/Ball Screw Drive: Vertical

LEJS40□H

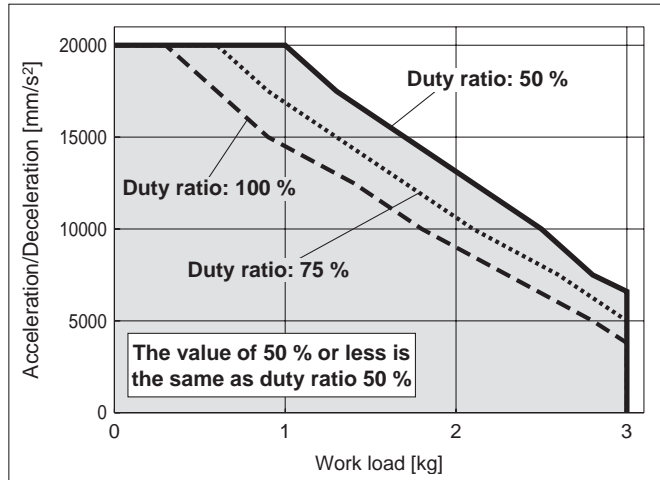

LEJS63/Ball Screw Drive: Vertical

LEJS63□H

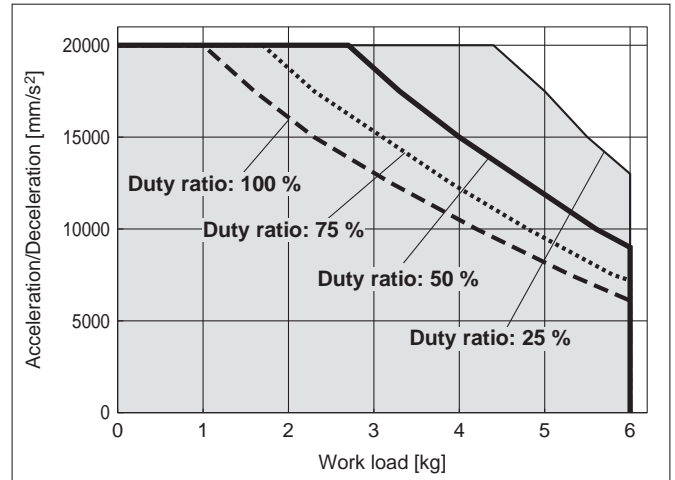

LEJS40□A

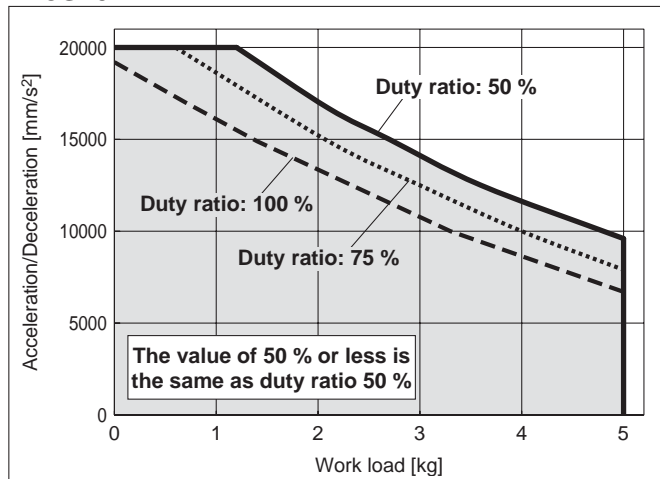

LEJS63□A

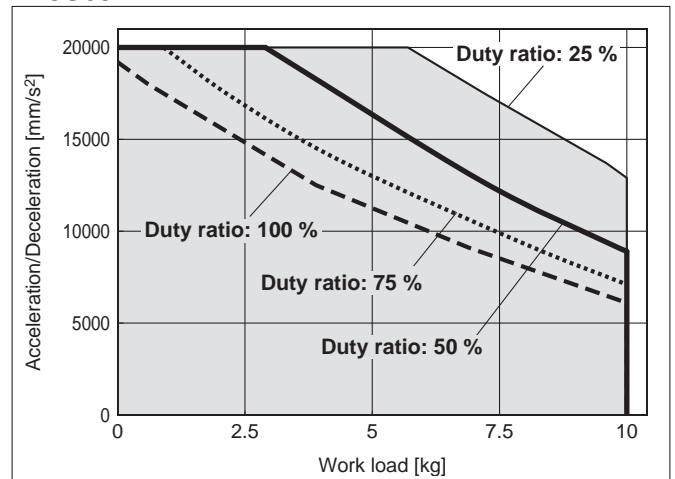

LEJS40□B

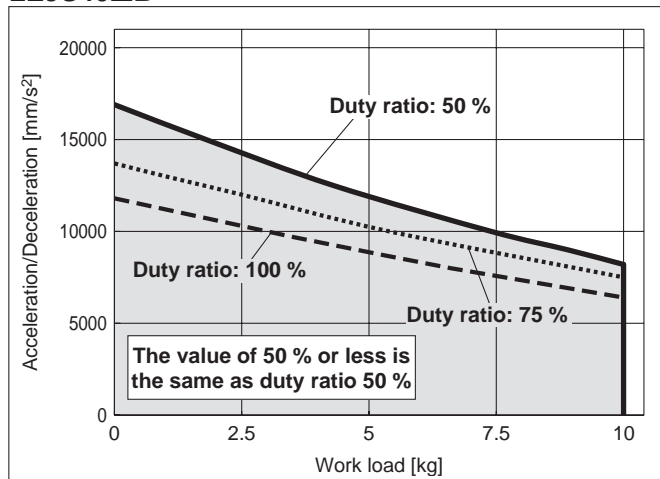

LEJS63□B

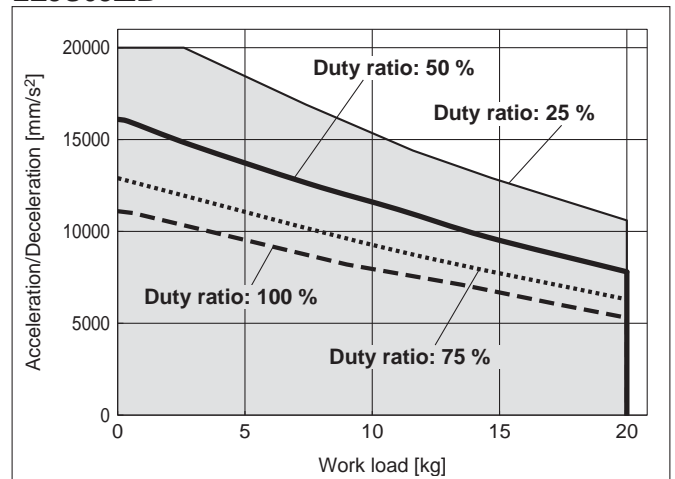





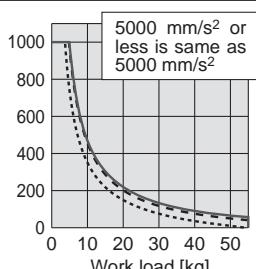
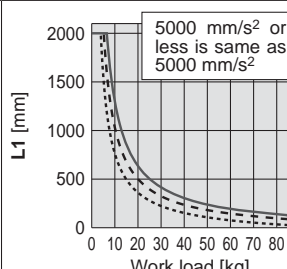
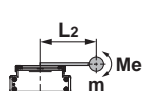
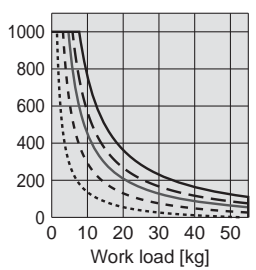
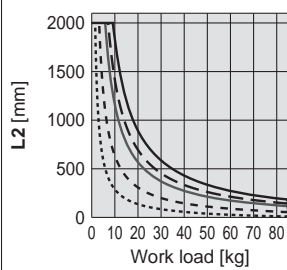

These graphs are examples of when the standard motor is mounted.
Determine the duty ratio after taking into account the load factor of the motor or driver to be used.

Dynamic Allowable Moment

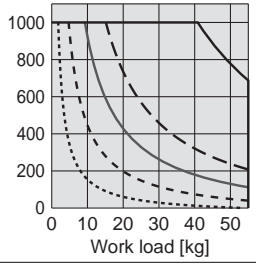
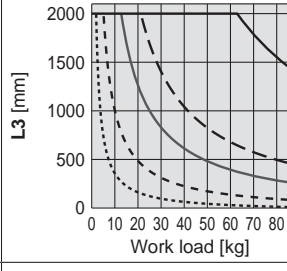
* This graph shows the amount of allowable overhang (guide unit) when the centre of gravity of the workpiece overhangs in one direction. When selecting the overhang, refer to "Calculation of Guide Load Factor" or the Electric Actuator Selection Software for confirmation, <http://www.smcworld.com>

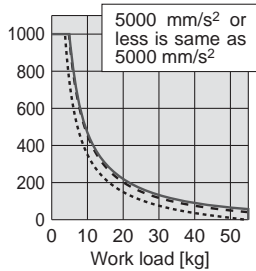
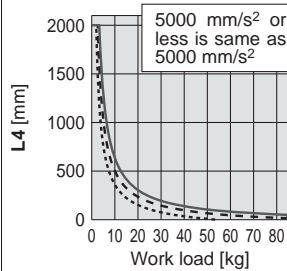
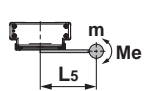
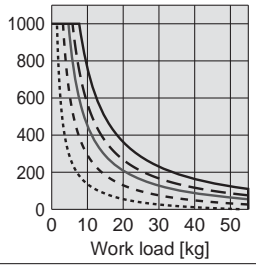
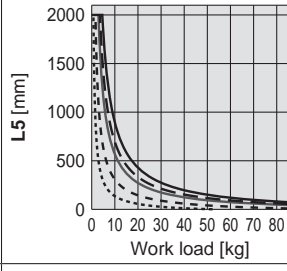
Acceleration/Deceleration ——— 1000 mm/s² - - - 3000 mm/s² ——— 5000 mm/s²
 - - - 10000 mm/s² ······ 20000 mm/s²

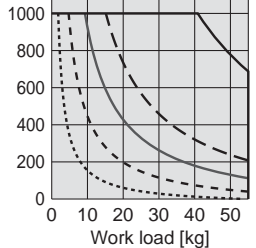
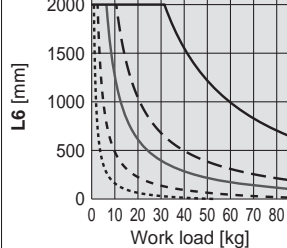
Orientation	Load overhanging direction m : Work load [kg] Me: Dynamic allowable moment [N·m] L : Overhang to the work load centre of gravity [mm]	Model	
		LEJS40	LEJS63
Horizontal	X 		
	Y 		
	Z 		
Bottom	X 		
	Y 		
	Z 		

Model Selection

LEFS

LEFB

LEJS

LEY

LEYG

Motor Mounting

Series LEJS

Motorless Type

* This graph shows the amount of allowable overhang (guide unit) when the centre of gravity of the workpiece overhangs in one direction. When selecting the overhang, refer to "Calculation of Guide Load Factor" or the Electric Actuator Selection Software for confirmation, <http://www.smc.eu>

Dynamic Allowable Moment

Acceleration/Deceleration ——— 1000 mm/s² - - - 3000 mm/s² ——— 5000 mm/s²
 - - - 10000 mm/s² ······ 20000 mm/s²

Orientation	Load overhanging direction m : Work load [kg] Me: Dynamic allowable moment [N·m] L : Overhang to the work load centre of gravity [mm]	Model	
		LEJS40	LEJS63
Wall mounted	X 		
	Y 		
	Z 		
Vertical	Y 		
	Z 		

Calculation of Guide Load Factor

1. Determine the operating conditions.

Model: LEJS

Size: 40/63

Mounting orientation: Horizontal/Wall mounted/Vertical

Acceleration [mm/s²]: **a**

Work load [kg]: **m**

Work load centre position [mm]: **Xc/Yc/Zc**

2. Select the target graph with reference to the model, size and mounting orientation.

3. Based on the acceleration and work load, obtain the overhang [mm]: **Lx/Ly/Lz** from the graph.

4. Calculate the load factor for each direction.

$$\alpha_x = X_c/L_x, \alpha_y = Y_c/L_y, \alpha_z = Z_c/L_z$$

5. Confirm the total of α_x , α_y and α_z is 1 or less.

$$\alpha_x + \alpha_y + \alpha_z \leq 1$$

When 1 is exceeded, consider a reduction of acceleration and work load, or a change of the work load centre position or the actuator series.

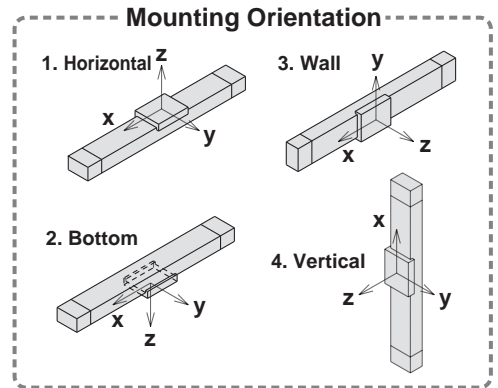

Example

1. Operating conditions

Model: LEJS

Size: 40

Mounting orientation: Horizontal

Acceleration [mm/s²]: 5000

Work load [kg]: 20

Work load centre position [mm]: **Xc = 0, Yc = 50, Zc = 200**

2. Refer to the graph on page 66, top and left side first row.

3. **Lx = 220 mm, Ly = 210 mm, Lz = 430 mm**

4. The load factor for each direction can be calculated as follows.

$$\alpha_x = 0/220 = 0$$

$$\alpha_y = 50/210 = 0.24$$

$$\alpha_z = 200/430 = 0.47$$

5. $\alpha_x + \alpha_y + \alpha_z = 0.71 \leq 1$

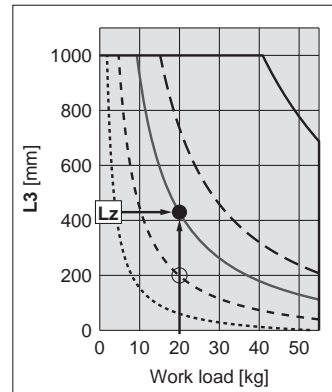
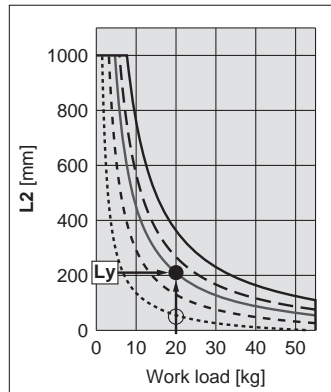
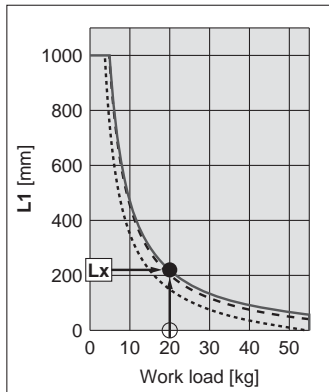

Series LEJS

Motorless Type

Table Accuracy (Reference Value)

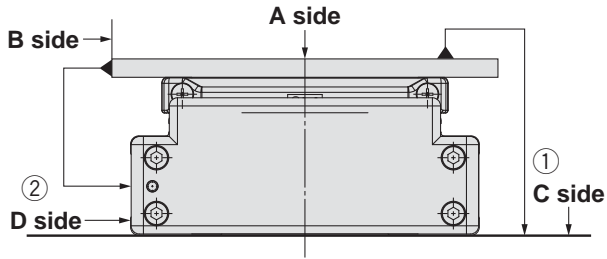

Model	Parallelism of travel [mm] (Every 300 mm)	
	① C side parallelism to A side	② D side parallelism to B side
LEJS40	0.05	0.03
LEJS63	0.05	0.03

Note) Parallelism of travel does not include the mounting surface accuracy.

Table Displacement (Reference Value)

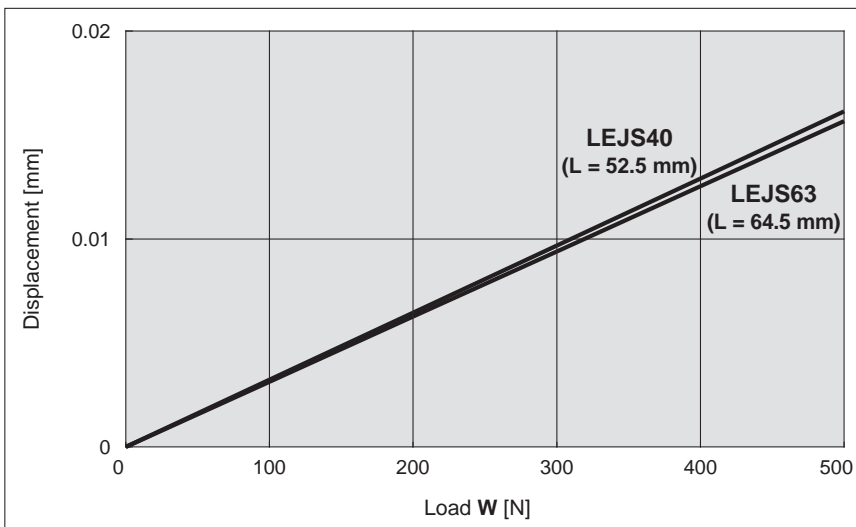
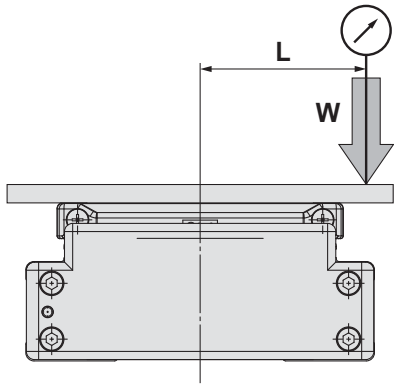

Note) This displacement is measured when a 15 mm aluminium plate is mounted and fixed on the table. (Table clearance is included.)

Model Selection

LEFS

LEFB

LEJS

LEY

LEYG

Motor Mounting

Electric Actuator/High Rigidity Slider Type Ball Screw Drive

Series **LEJS** LEJS40, 63



How to Order

LEJS **H** **40** **NZ** **A** - **500**

① ② ③ ④ ⑤

① Accuracy

—	Basic type
H	High precision type

② Size

40
63

③ Motor type

Symbol	Type
NZ	Mounting type Z
NY	Mounting type Y
NX	Mounting type X
NW*	Mounting type W
NV*	Mounting type V
NU*	Mounting type U
NT*	Mounting type T

* Size 63 only

④ Lead [mm]

Symbol	LEJS40	LEJS63
H	24	30
A	16	20
B	8	10

⑤ Stroke [mm]

200
to
1500

* For details, refer to the table below.

Applicable Stroke Table

●: Standard

Model	Stroke [mm]	200	300	400	500	600	700	800	900	1000	1200	1500
LEJS40		●	●	●	●	●	●	●	●	●	●	—
LEJS63		—	●	●	●	●	●	●	●	●	●	●

* Please consult with SMC for non-standard strokes as they are produced as special orders.

For auto switches, refer to pages 78 to 80.

Compatible Motors

Applicable motor model			Size/Motor type									
Manufacturer	Series	Type	40			63						
			NZ Mounting type Z	NY Mounting type Y	NX Mounting type X	NZ Mounting type Z	NY Mounting type Y	NX Mounting type X	NW Mounting type W	NV Mounting type V	NU Mounting type U	NT Mounting type T
Mitsubishi Electric Corporation	MELSERVO-JN	HF-KN	●	—	—	●	—	—	—	—	—	—
	MELSERVO-J3	KF-KP	●	—	—	●	—	—	—	—	—	—
	MELSERVO-J4	HG-KR	●	—	—	●	—	—	—	—	—	—
YASKAWA Electric Corporation	Σ-V	SGMJV	●	—	—	●	—	—	—	—	—	—
SANYO DENKI CO., LTD.	SANMOTION R	R2	●	—	—	●	—	—	—	—	—	—
OMRON Corporation	Sysmac G5	R88M-K	●	—	—	—	●	—	—	—	—	—
Panasonic Corporation	MINAS-A4	MSMD	—	●	—	—	●	—	—	—	—	—
	MINAS-A5	MSMD/MHMD	—	●	—	—	●	—	—	—	—	—
FANUC CORPORATION	βis	β	●	—	—	● (nur β1)	—	—	●	—	—	—
NIDEC SANKYO CORPORATION	S-FLAG	MA/MH/MM	●	—	—	●	—	—	—	—	—	—
KEYENCE CORPORATION	SV	SV-M/SV-B	●	—	—	●	—	—	—	—	—	—
FUJI ELECTRIC CO., LTD.	ALPHA5	GYS/GYB	●	—	—	●	—	—	—	—	—	—
	FALDIC-α	GYS	●	—	—	●	—	—	—	—	—	—
Rockwell Automation, Inc. (Allen-Bradley)	MP-/VP-	MP/VP	—	—	—	—	—	●	—	—	—	—
	TL	TLY-A	●	—	—	—	—	—	—	—	—	●
Beckhoff Automation GmbH	AM	AM30	●	—	—	—	—	—	—	●	—	—
	AM	AM31	●	—	—	—	—	—	—	—	●	—
	AM	AM80/AM81	●	—	—	—	—	●	—	—	—	—
Siemens AG	1FK7	1FK7	—	—	●	—	—	●	—	—	—	—
	1FK2	1FK2	●	—	—	●	—	—	—	—	●	—
Delta Electronics, Inc.	ASDA-A2	ECMA	●	—	—	●	—	—	—	—	—	—

Specifications

- The values given below are within the actuator body specification range, with a standard motor mounted and should not be exceeded.

Model		LEJS40			LEJS63					
Stroke [mm] ^{Note 1)}		200, 300, 400, 500, 600, 700, 800 900, 1000, 1200			300, 400, 500, 600, 700, 800, 900 1000, 1200, 1500					
Work load [kg] ^{Note 2)}		Horizontal	15	30	55	30	45	85		
		Vertical	3	5	10	6	10	20		
Speed [mm/s] ^{Note 3)}	Stroke range	Up to 500	1800	1200	600	1800	1200	600		
		501 to 600	1580	1050	520					
		601 to 700	1170	780	390					
				701 to 800	910	600	300	1390	930	460
				801 to 900	720	480	240	1110	740	370
				901 to 1000	580	390	190	900	600	300
				1001 to 1100	480	320	160	750	500	250
				1101 to 1200	410	270	130	630	420	210
				1201 to 1300	—	—	—	540	360	180
				1301 to 1400	—	—	—	470	310	150
		1401 to 1500	—	—	—	410	270	130		
Max. acceleration/deceleration [mm/s²]		20000								
Positioning repeatability [mm]		Basic type	±0.02							
		High precision type	±0.01							
Lost motion [mm] ^{Note 4)}		Basic type	0.1 or less							
		High precision type	0.05 or less							
Ball screw specifications		Thread size [mm]	Ø 12			Ø 15				
		Lead [mm]	24	16	8	30	20	10		
		Shaft length [mm]	Stroke + 118.5			Stroke + 126.5				
Impact/Vibration resistance [m/s²] ^{Note 5)}		50/20								
Actuation type		Ball screw								
Guide type		Linear guide								
Operating temperature range [°C]		5 to 40								
Operating humidity range [%RH]		90 or less (No condensation)								
Actuation unit weight [kg]		0.86			1.37					
Other inertia [kg·cm²]		0.031			0.129					
Coefficient of friction		0.05								
Mechanical efficiency		0.8								
Motor shape		□40			□60					
Motor type		AC servo motor (100 V/200 V)								
Rated output capacity [W]		100			200					
Rated torque [N·m]		0.32			0.64					
Rated rotation [rpm]		3000			3000					

Note 1) Please consult with SMC for non-standard strokes as they are produced as special orders.

Note 2) Check the "Speed-Work Load Graph (Guide)" on page 62.

Note 3) The allowable speed will vary according to the stroke.

Note 4) A reference value for correcting an error in reciprocal operation.

Note 5) Impact resistance: No malfunction occurred when the actuator was tested with a drop tester in both an axial direction and a perpendicular direction to the lead screw. (Test was performed with the actuator in the initial state.)

Vibration resistance: No malfunction occurred in a test ranging between 45 to 2000 Hz. Test was performed in both an axial direction and a perpendicular direction to the lead screw. (Test was performed with the actuator in the initial state.)

Note 6) The values are a guide only and should be used to select a motor capacity.

Note 7) Sensor magnet position is located at the table centre.

For detailed dimensions, refer to the "Auto Switch Mounting Position."

Note 8) Do not allow collisions at either end of the table.

Additionally, when running the positioning operation, do not set within 2 mm of either end.

Note 9) Please consult with SMC for the manufacture of intermediate strokes.

(LEJS40/Manufacturable stroke range: 200 to 1200 mm, LEJS63/Manufacturable stroke range: 300 to 1500 mm)

Weight

Model	LEJS40									
Stroke [mm]	200	300	400	500	600	700	800	900	1000	1200
Weight [kg]	5.0	5.8	6.5	7.3	8.1	8.8	9.6	10.4	11.1	12.7

Model	LEJS63									
Stroke [mm]	300	400	500	600	700	800	900	1000	1200	1500
Weight [kg]	10.4	11.7	12.9	14.2	15.4	16.7	17.9	19.1	21.6	25.4

Series LEJS

Motorless Type

Refer to the "Motor Mounting" on page 75 for details of motor mounting and parts included.

Dimensions: Ball Screw Drive

LEJS40

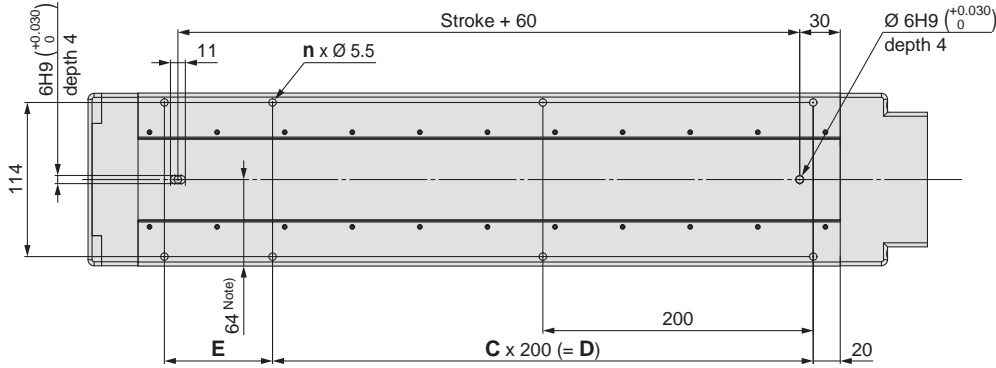

Mounting type: Y
LEJS40NY□-□

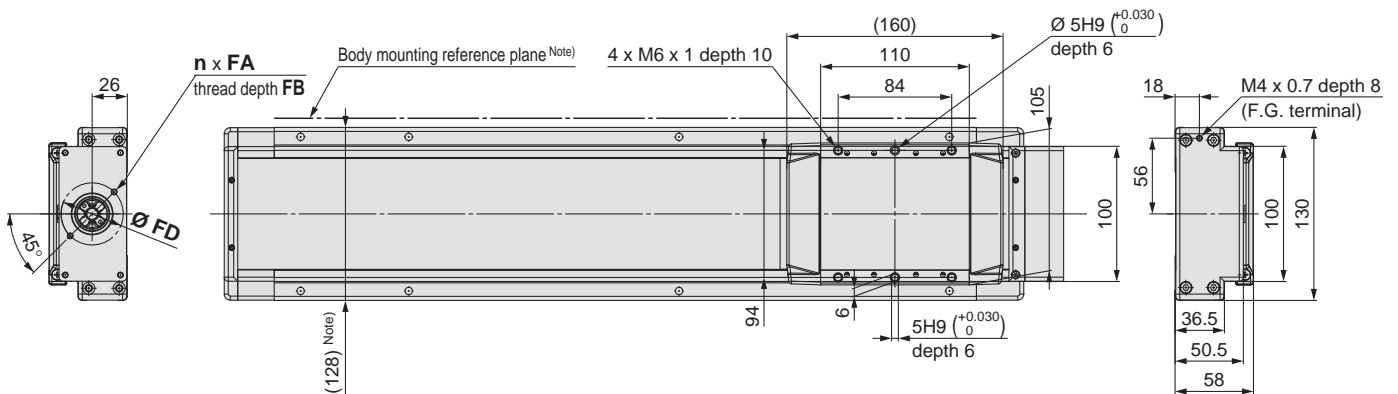
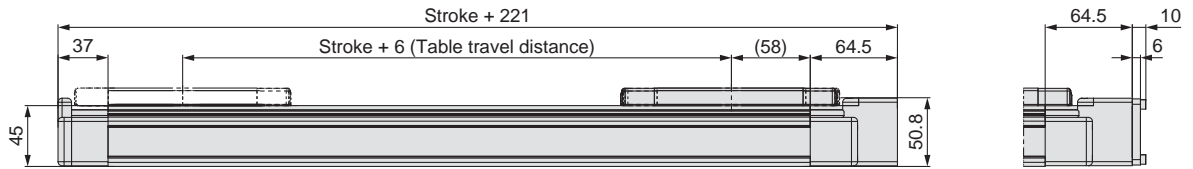

Note) When mounting the actuator using the body mounting reference plane. Set the height of the mating surface or positioning pins to 5 mm minimum. (Recommended height 6 mm)

Dimensions [mm]

Model	n	C	D	E
LEJS40N□□-200	6	1	200	80
LEJS40N□□-300	6	1	200	180
LEJS40N□□-400	8	2	400	80
LEJS40N□□-500	8	2	400	180
LEJS40N□□-600	10	3	600	80
LEJS40N□□-700	10	3	600	180
LEJS40N□□-800	12	4	800	80
LEJS40N□□-900	12	4	800	180
LEJS40N□□-1000	14	5	1000	80
LEJS40N□□-1200	16	6	1200	80

Motor Mounting Dimensions [mm]

Motor type	n	FA	FB	FD
NZ/Mounting type Z	2	M4 x 0.7	7	46
NY/Mounting type Y	4	M3 x 0.5	6	45
NX/Mounting type X	2	M4 x 0.7	7	46

Refer to the "Motor Mounting" on page 75 for details of motor mounting and parts included.

Dimensions: Ball Screw Drive

LEJS63

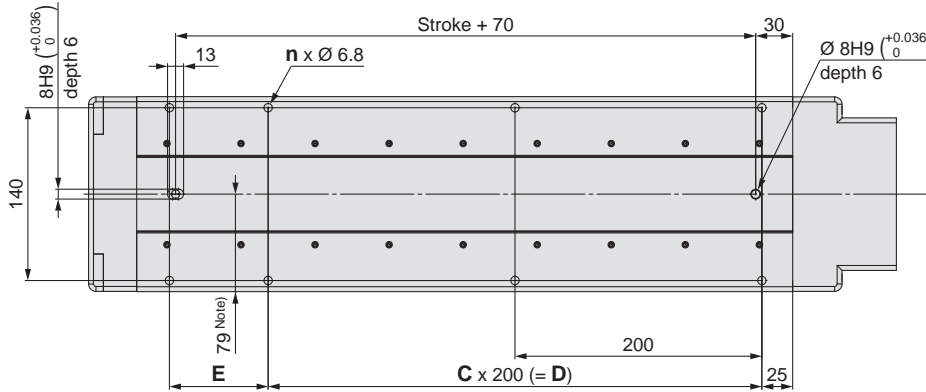

Mounting type: Y, X, V
LEJS63NY□-□
LEJS63NX□-□
LEJS63NV□-□

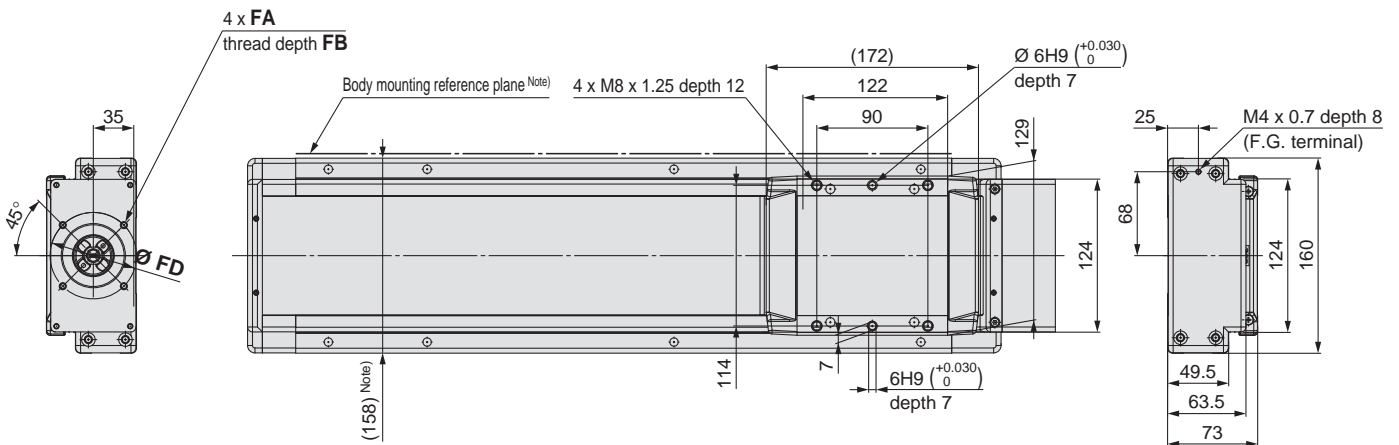
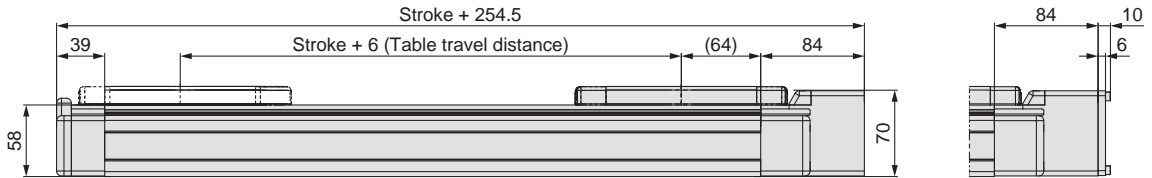

Note) When mounting the actuator using the body mounting reference plane. Set the height of the mating surface or positioning pins to 5 mm minimum. (Recommended height 6 mm)

Dimensions [mm]

Model	n	C	D	E
LEJS63N□□-300	6	1	200	180
LEJS63N□□-400	8	2	400	80
LEJS63N□□-500	8	2	400	180
LEJS63N□□-600	10	3	600	80
LEJS63N□□-700	10	3	600	180
LEJS63N□□-800	12	4	800	80
LEJS63N□□-900	12	4	800	180
LEJS63N□□-1000	14	5	1000	80
LEJS63N□□-1200	16	6	1200	80
LEJS63N□□-1500	18	7	1400	180

Motor Mounting Dimensions [mm]

Motor type	FA	FB	FD
NZ/Mounting type Z	M5 x 0.8	7	70
NY/Mounting type Y	M4 x 0.7	6	70
NX/Mounting type X	M5 x 0.8	6	63
NW/Mounting type W	M5 x 0.8	7	70
NV/Mounting type V	M4 x 0.7	6	63
NU/Mounting type U	M5 x 0.8	7	70
NT/Mounting type T	M5 x 0.8	7	70

Series LEJS

Motorless Type

- When mounting a hub, remove any oil, dust, or dirt from the shaft and hub inside diameter.
- This product does not include the motor and motor mounting screws. (Provided by user)
The motor drive shaft shape should be of the plain round type, without a keyway.
- Take measures to prevent the motor mounting screws becoming loose.

Motor Mounting

Hexagon socket (thin) head cap screw: **MM**
(Tightening torque: **TT** [N·m])

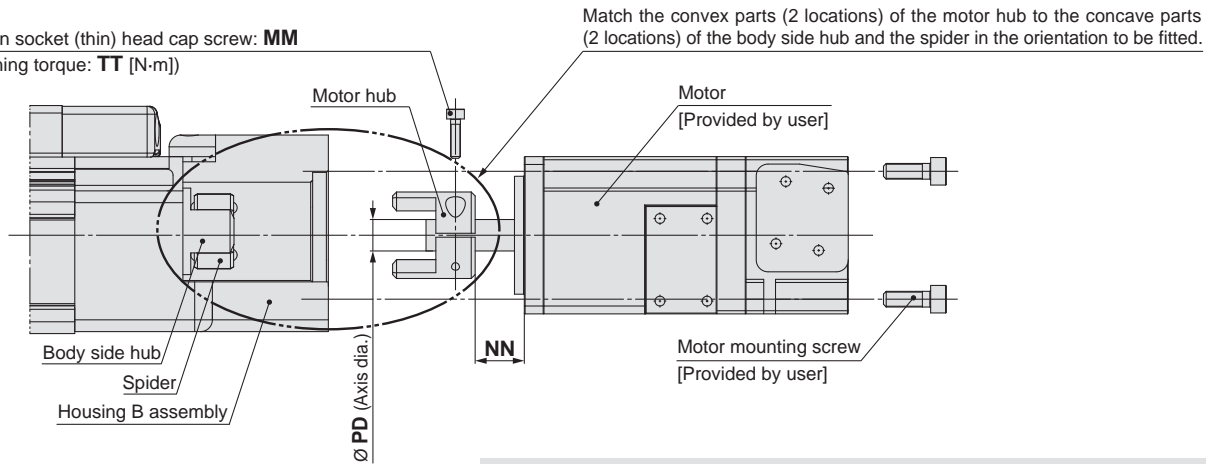

Note) All parts are included except where stated
“(provided by user)”

Mounting procedure

- 1) Fix the motor (provided by user) and the “motor hub” with the “MM hexagon socket head cap screw.”
- 2) Check the “motor hub position”, and then insert it.
- 3) Fix the motor and the “housing B assembly” with the motor mounting screws (provided by user).

Dimensions

Size	Motor type	MM	TT	NN	PD
40	NZ/Mounting type Z	M2.5 x 10	0.65	12.5	8
	NY/Mounting type Y	M2.5 x 10	0.65	12.5	8
	NX/Mounting type X	M2.5 x 10	0.65	7	8
63	NZ/Mounting type Z	M3 x 12	1.5	18	14
	NY/Mounting type Y	M4 x 12	2.7	18	11
	NX/Mounting type X	M4 x 12	2.7	8	9
	NW/Mounting type W	M4 x 12	2.7	12	9
	NV/Mounting type V	M4 x 12	2.7	8	9
	NU/Mounting type U	M4 x 12	2.7	12	11
	NT/Mounting type T	M3 x 12	1.5	18	12

Parts List

Size: 40

Description	Quantity	Note
Motor hub	1	—
Hexagon socket head cap screw (for hub fixing)	1	M2.5 x 10: Motor type “NZ”, “NY”, “NX”

Size: 63

Description	Quantity	Note
Motor hub	1	—
Hexagon socket head cap screw (for hub fixing)	1	M3 x 12: Motor type “NZ”, “NT”
Hexagon socket thin head cap screw (for hub fixing)		M4 x 12: Motor type “NY”, “NX”, “NW”, “NV”, “NU”

Series LEJS

Motor Mounting Parts

Motor Flange Option

As all the motor types that are not "NZ" are mounted over the motor type "NZ", the motor types that can be used are shown below.

How to Order

LEJ-MF **63** D-**NY**

①

②

① Size

40	For LEJ40
63	For LEJ63

② Motor type

Symbol	Type
NY	Mounting type Y
NX	Mounting type X
NW	Mounting type W
NV	Mounting type V
NU	Mounting type U
NT	Mounting type T

* Component parts vary depending on the motor type. Refer to "Parts List" on page 77.

Compatible Motors

Applicable motor model			Size/Motor type									
Manufacturer	Series	Type	40			63						
			NZ Mounting type Z	NY Mounting type Y	NX Mounting type X	NZ Mounting type Z	NY Mounting type Y	NX Mounting type X	NW Mounting type W	NV Mounting type V	NU Mounting type U	NT Mounting type T
Mitsubishi Electric Corporation	MELSERVO-JN	HF-KN	●	—	—	●	—	—	—	—	—	—
	MELSERVO-J3	KF-KP	●	—	—	●	—	—	—	—	—	—
	MELSERVO-J4	HG-KR	●	—	—	●	—	—	—	—	—	—
YASKAWA Electric Corporation	Σ-V	SGMJV	●	—	—	●	—	—	—	—	—	—
SANYO DENKI CO., LTD.	SANMOTION R	R2	●	—	—	●	—	—	—	—	—	—
OMRON Corporation	Sysmac G5	R88M-K	●	—	—	—	●	—	—	—	—	—
Panasonic Corporation	MINAS-A4	MSMD	—	●	—	—	●	—	—	—	—	—
	MINAS-A5	MSMD/MHMD	—	●	—	—	●	—	—	—	—	—
FANUC CORPORATION	βis	β	●	—	—	● (β1 only)	—	—	●	—	—	—
NIDEC SANKYO CORPORATION	S-FLAG	MA/MH/MM	●	—	—	●	—	—	—	—	—	—
KEYENCE CORPORATION	SV	SV-M/SV-B	●	—	—	●	—	—	—	—	—	—
FUJI ELECTRIC CO., LTD.	ALPHA5	GYS/GYB	●	—	—	●	—	—	—	—	—	—
	FALDIC-α	GYS	●	—	—	●	—	—	—	—	—	—
Rockwell Automation, Inc. (Allen-Bradley)	MP-/VP-	MP/VP	—	—	—	—	—	●	—	—	—	—
	TL	TLY-A	●	—	—	—	—	—	—	—	—	●
Beckhoff Automation GmbH	AM	AM30	●	—	—	—	—	—	—	●	—	—
	AM	AM31	●	—	—	—	—	—	—	—	●	—
	AM	AM80/AM81	●	—	—	—	—	●	—	—	—	—
Siemens AG	1FK7	1FK7	—	—	●	—	—	●	—	—	—	—
	1FK2	1FK2	●	—	—	●	—	—	—	—	●	—
Delta Electronics, Inc.	ASDA-A2	ECMA	●	—	—	●	—	—	—	—	—	—

Model Selection

LEFS

LEFB

LEJS

LEY

LEYG

Motor Mounting

Series LEJS

Motorless Type

Dimensions: Motor Flange Option

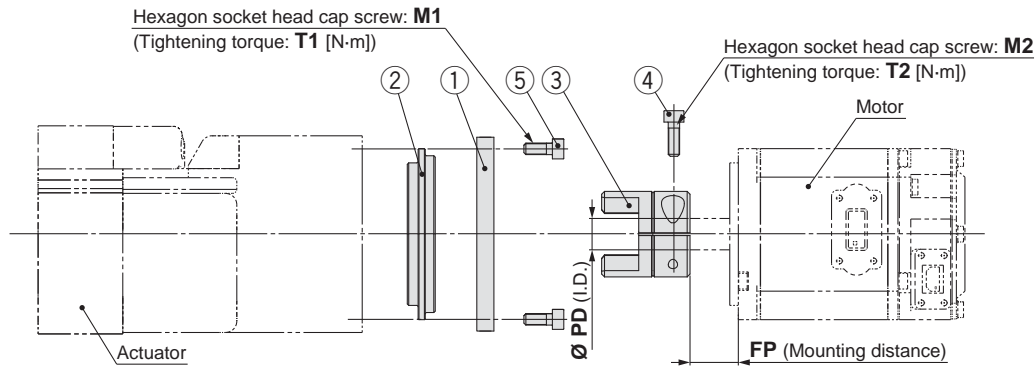

Motor plate details

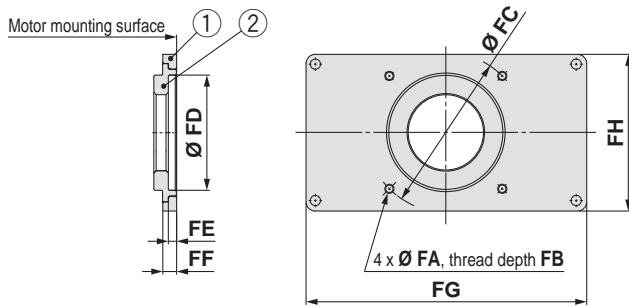

Dimensions

Size	Motor type	FA	FB	FC	FD	FE	FF	FG	FH	M1	T1	M2	T2	PD	FP
40	NY	M3 x 0.5	6	45	30	3.5	6	99	49	M4 x 12	2.7	M2.5 x 10	0.65	8	12.5
	NX	—	—	—	—	—	—	—	—	—	—	M2.5 x 10	0.65	8	7
63	NY	M4 x 0.7	6	70	50	3.5	6	123	68	M4 x 12	2.7	M4 x 12	2.7	11	18
	NX	M5 x 0.8	6	63	40	3.5	6	123	68	M4 x 12	2.7	M4 x 12	2.7	9	8
	NW	—	—	—	—	—	—	—	—	—	—	M4 x 12	2.7	9	12
	NV	M4 x 0.7	6	63	40	3.5	6	123	68	M4 x 12	2.7	M4 x 12	2.7	9	8
	NU	—	—	—	—	—	—	—	—	—	—	M4 x 12	2.7	11	12
	NT	—	—	—	—	—	—	—	—	—	—	M3 x 12	1.5	12	18

Parts List

Size: 40

No.	Description	Quantity	
		Motor type	
		NY	NX
1	Motor plate	1	—
2	Ring	1	—
3	Hub (Motor side)	1	1
4	Hexagon socket thin head cap screw	1	1
5	Hexagon socket head cap screw	4	—

Size: 63

No.	Description	Quantity					
		Motor type					
		NY	NX	NW	NV	NU	NT
1	Motor plate	1	1	—	1	—	—
2	Ring	1	1	—	1	—	—
3	Hub (Motor side)	1	1	1	1	1	1
4	Hexagon socket thin head cap screw	1	1	1	1	1	1
5	Hexagon socket head cap screw	4	4	—	4	—	—

Series LEJS Auto Switch Mounting

Auto Switch Mounting Position

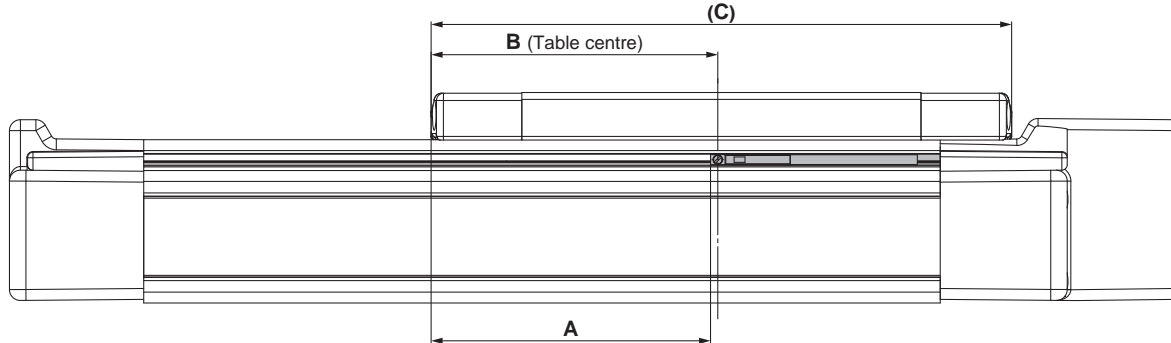

[mm]					
Model	Size	A	B	C	Operating range
LEJS	40	77	80	160	5.5
	63	83	86	172	7.0

Note) Since the operating range is provided as a guideline including hysteresis, it cannot be guaranteed (assuming approximately $\pm 30\%$ dispersion). It may change substantially depending on the ambient environment.

Auto Switch Mounting

When mounting the auto switches, they should be inserted into the actuator's auto switch mounting groove as shown in the drawing below. After setting in the mounting position, use a small flat blade screwdriver to tighten the auto switch mounting screw that is included.

Auto Switch Mounting Screw Tightening Torque [N·m]

Auto switch model	Tightening torque
D-M9□(V) D-M9□W(V)	0.10 to 0.15

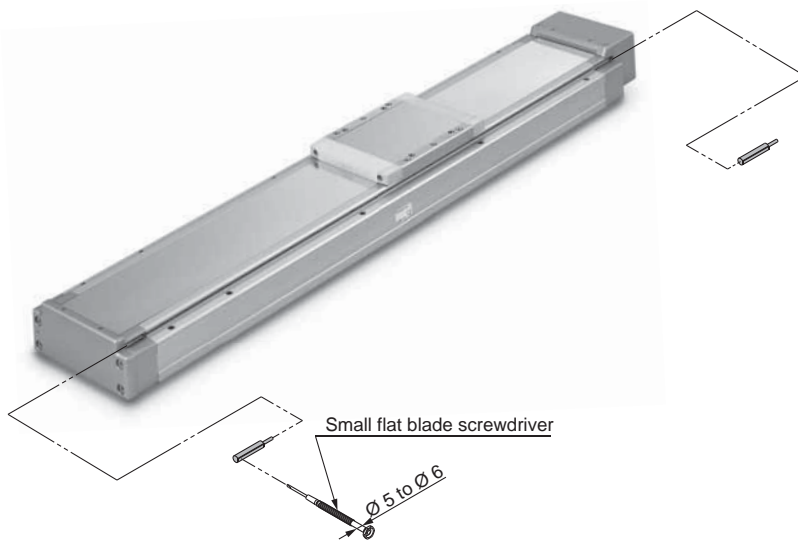

Note) When tightening the auto switch mounting screw, use a small flat blade screwdriver with a handle diameter of approximately 5 to 6 mm.

Model Selection

LEFS

LEFB

LEJS

LEY

LEYG

Motor Mounting

Solid State Auto Switch Direct Mounting Style

D-M9N(V)/D-M9P(V)/D-M9B(V)



Refer to the SMC website for details about products conforming to the international standards.

Grommet

- 2-wire load current is reduced (2.5 to 40 mA).
- Using flexible cable as standard.



Auto Switch Specifications

PLC: Programmable Logic Controller

D-M9□, D-M9□V (With indicator light)						
Auto switch model	D-M9N	D-M9NV	D-M9P	D-M9PV	D-M9B	D-M9BV
Electrical entry	In-line	Perpendicular	In-line	Perpendicular	In-line	Perpendicular
Wiring type	3-wire			2-wire		
Output type	NPN		PNP		—	
Applicable load	IC circuit, Relay, PLC				24 V DC relay, PLC	
Power supply voltage	5, 12, 24 V DC (4.5 to 28 V)				—	
Current consumption	10 mA or less				—	
Load voltage	28 V DC or less		—		24 V DC (10 to 28 V DC)	
Load current	40 mA or less				2.5 to 40 mA	
Internal voltage drop	0.8 V or less at 10 mA (2 V or less at 40 mA)				4 V or less	
Leakage current	100 μA or less at 24 V DC				0.8 mA or less	
Indicator light	Red LED lights up when turned ON.					
Standards	CE marking, RoHS					

Oilproof Heavy-duty Lead Wire Specifications

Auto switch model		D-M9N(V)	D-M9P(V)	D-M9B(V)
Sheath	Outside diameter [mm]	2.6		
Insulator	Number of cores	3 cores (Brown/Blue/Black)		2 cores (Brown/Blue)
	Outside diameter [mm]	0.88		
Conductor	Effective area [mm ²]	0.15		
	Strand diameter [mm]	0.05		
Minimum bending radius [mm] (Reference value)		17		

Note 1) Refer to the Auto Switch Guide for solid state auto switch common specifications.
Note 2) Refer to the Auto Switch Guide for lead wire lengths.

Caution

Precautions

Fix the auto switch with the screw installed on the auto switch body. The auto switch may be damaged if a screw other than the one supplied is used.

Weight

[g]

Auto switch model		D-M9N(V)	D-M9P(V)	D-M9B(V)
Lead wire length	0.5 m (—)	8	7	7
	1 m (M)	14	13	13
	3 m (L)	41	38	38
	5 m (Z)	68	63	63

Dimensions

[mm]

D-M9□

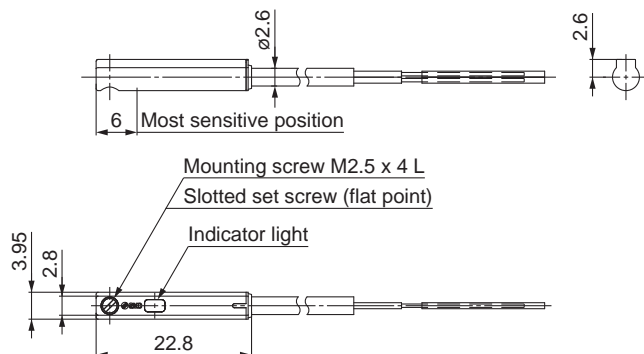

D-M9□V

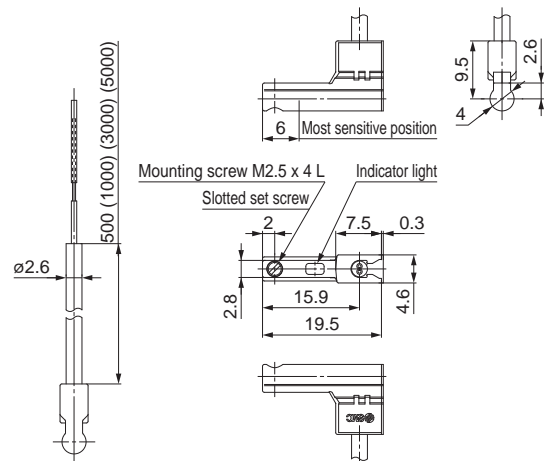

2-Colour Indication Solid State Auto Switch Direct Mounting Style

D-M9NW(V)/D-M9PW(V)/D-M9BW(V)



Refer to the SMC website for details about products conforming to the international standards.

Auto Switch Specifications

PLC: Programmable Logic Controller

D-M9□W, D-M9□WV (With indicator light)						
Auto switch model	D-M9NW	D-M9NWV	D-M9PW	D-M9PWV	D-M9BW	D-M9BWV
Electrical entry	In-line	Perpendicular	In-line	Perpendicular	In-line	Perpendicular
Wiring type	3-wire			2-wire		
Output type	NPN		PNP		—	
Applicable load	IC circuit, Relay, PLC				24 V DC relay, PLC	
Power supply voltage	5, 12, 24 V DC (4.5 to 28 V)				—	
Current consumption	10 mA or less				—	
Load voltage	28 V DC or less		—		24 V DC (10 to 28 V DC)	
Load current	40 mA or less				2.5 to 40 mA	
Internal voltage drop	0.8 V or less at 10 mA (2 V or less at 40 mA)				4 V or less	
Leakage current	100 μA or less at 24 V DC				0.8 mA or less	
Indicator light	Operating range Red LED lights up. Optimum operating range Green LED lights up.					
Standards	CE marking, RoHS					

Oilproof Flexible Heavy-duty Lead Wire Specifications

Auto switch model		D-M9NW(V)	D-M9PW(V)	D-M9BW(V)
Sheath	Outside diameter [mm]	2.6		
Insulator	Number of cores	3 cores (Brown/Blue/Black)		2 cores (Brown/Blue)
	Outside diameter [mm]	0.88		
Conductor	Effective area [mm ²]	0.15		
	Strand diameter [mm]	0.05		
Minimum bending radius [mm] (Reference value)		17		

Note 1) Refer to the Auto Switch Guide for solid state auto switch common specifications.
Note 2) Refer to the Auto Switch Guide for lead wire lengths.

Weight

[g]

Auto switch model		D-M9NW(V)	D-M9PW(V)	D-M9BW(V)
Lead wire length	0.5 m (—)	8	7	7
	1 m (M)	14	13	13
	3 m (L)	41	38	38
	5 m (Z)	68	63	63

Grommet

- 2-wire load current is reduced (2.5 to 40 mA).
- Using flexible cable as standard.
- The optimum operating range can be determined by the colour of the light. (Red → Green ← Red)



Caution

Precautions

Fix the auto switch with the screw installed on the auto switch body. The auto switch may be damaged if a screw other than the one supplied is used.

Dimensions

[mm]

D-M9□W

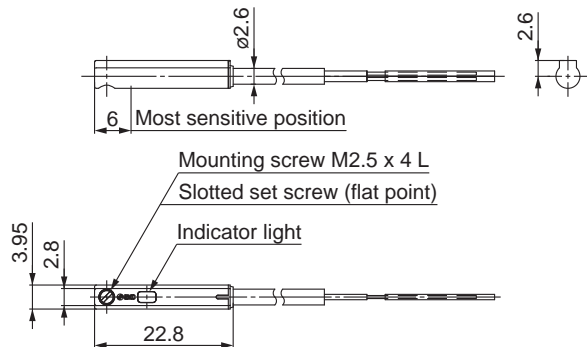

D-M9□WV

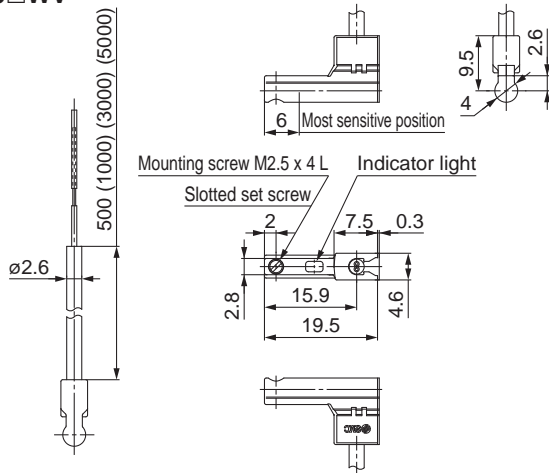

Model Selection
LEFS
LEFB
LEJS
LEY
LEYG
Motor Mounting



Series LEJS Electric Actuator Specific Product Precautions 1

Be sure to read this before handling. Refer to the back cover for Safety Instructions. For Electric Actuator Precautions, refer to “Handling Precautions for SMC Products” and the Operation Manual on the SMC website, <http://www.smc.eu>

Design

⚠ Caution

1. Do not apply a load in excess of the specification limits.

Select a suitable actuator by work load and allowable moment. If the product is used outside of the specification limits, the eccentric load applied to the guide will be excessive and have adverse effects such as creating play on the guide, degrading accuracy and shortening the life of the product.

2. Do not use the product in applications where excessive external force or impact force is applied to it.

The product can be damaged.

The components including the motor are manufactured to precise tolerances, so that even a slight deformation may cause a malfunction or seizure.

Selection

⚠ Warning

1. Do not increase the speed in excess of the specification limits.

Select a suitable actuator by the relationship of the allowable work load and speed, and the allowable speed of each stroke. If the product is used outside of the specification limits, it will have adverse effects such as creating noise, degrading accuracy and shortening the life of the product.

2. When the product repeatedly cycles with partial strokes (100 mm or less), the lubrication can run out. Operate it at a full stroke at least once a day or every a thousand cycles.
3. When external force is applied to the table, it is necessary to add external force to the work load as the total carried load for the sizing.

When a cable duct or flexible moving tube is attached to the actuator, the sliding resistance of the table increases and may lead to operational failure of the product.

Handling

⚠ Caution

1. Do not allow the table to hit the end of stroke.

When the driver parameters, origin or programs are set incorrectly, the table may collide against the stroke end of the actuator during operation. Check these points before use.

If the table collides against the stroke end of the actuator, the guide, ball screw, belt or internal stopper can be broken. This may lead to abnormal operation.



Handle the actuator with care when it is used in the vertical direction as the workpiece will fall freely due to its own weight.

2. The actual speed of this actuator is affected by the work load and stroke.

Check the specifications with reference to the model selection section of the catalogue.

3. Do not apply a load, impact or resistance in addition to the transferred load during return to origin.

4. Do not dent, scratch or cause other damage to the body and table mounting surfaces.

This may cause unevenness in the mounting surface, play in the guide or an increase in the sliding resistance.

5. Do not apply strong impact or an excessive moment while mounting the product or a workpiece.

If an external force above the allowable moment is applied, it may cause play in the guide or an increase in the sliding resistance.

6. The flatness of mounting surface should be within 0.1 mm/500 mm.

Unevenness of a workpiece or base mounted on the body of the product may cause play in the guide and an increase in the sliding resistance.

In the case of overhang mounting (including cantilever), use a support plate or support guide to avoid deflection of the actuator body.

7. When mounting the actuator, use all mounting holes.

If all mounting holes are not used, it influences the specifications, e.g., the amount of displacement of the table increases.

8. Do not hit the table with the workpiece in the positioning operation and positioning range.

9. Do not apply external force to the dust seal band.

Particularly during the transportation



Series LEJS Electric Actuator Specific Product Precautions 2

Be sure to read this before handling. Refer to the back cover for Safety Instructions. For Electric Actuator Precautions, refer to “Handling Precautions for SMC Products” and the Operation Manual on the SMC website, <http://www.smc.eu>

Handling

⚠ Caution

10. When mounting the product, use screws with adequate length and tighten them with adequate torque.

Tightening the screws with a higher torque than recommended may cause a malfunction, whilst tightening with a lower torque can cause the displacement of the mounting position or in extreme conditions the actuator could become detached from its mounting position.

Body fixed

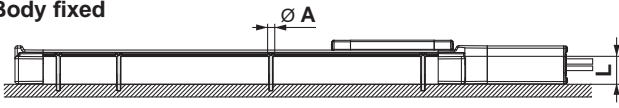

Model	Screw size	Max. tightening torque [N·m]	Ø A [mm]	L [mm]
LEJS40	M5	3.0	5.5	36.5
LEJS63	M6	5.2	6.8	49.5

Workpiece fixed

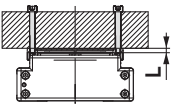

Model	Screw size	Max. tightening torque [N·m]	L (Max. screw-in depth) [mm]
LEJS40	M6 x 1	5.2	10
LEJS63	M8 x 1.25	12.5	12

To prevent the workpiece retaining screws from interfering with the body, use screws that are at least 0.5 mm shorter than the maximum screw-in depth. If long screws are used, they can touch the body and cause a malfunction.

11. Do not operate with the table fixed and the actuator body moving.

12. When mounting the actuator using the body mounting reference plane, set the height of the mating surface or positioning pins to 5 mm minimum. (Recommended height 6 mm)

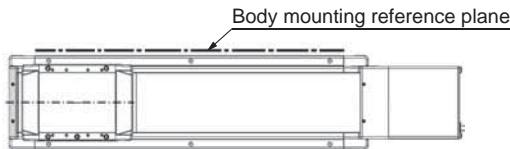

Maintenance

⚠ Warning

Maintenance frequency

Perform maintenance according to the table below.

Frequency	Appearance check	Internal check
Inspection before daily operation	○	—
Inspection every 6 months/1000 km/5 million cycles*	○	○

* Select whichever comes first.

• Items for visual appearance check

1. Loose set screws, Abnormal dirt
2. Check of flaw and cable joint
3. Vibration, Noise

• Items for internal check

1. Lubricant condition on moving parts.
* For lubrication, use lithium grease No. 2.
2. Loose or mechanical play in fixed parts or fixing screws.

Model Selection

LEFS

LEFB

LEJS

LEY

LEYG

Motor Mounting

Rod Type Series LEY



Guide Rod Type Series LEYG



Model Selection

LEFS

LEFB

LEJS

LEY

LEYG

Motor Mounting



Selection Procedure

Positioning Control Selection Procedure



Selection Example

Operating conditions

- Work load: 16 [kg]
- Speed: 300 [mm/s]
- Acceleration/Deceleration: 5000 [mm/s²]
- Stroke: 300 [mm]
- Workpiece mounting condition: Vertical transfer

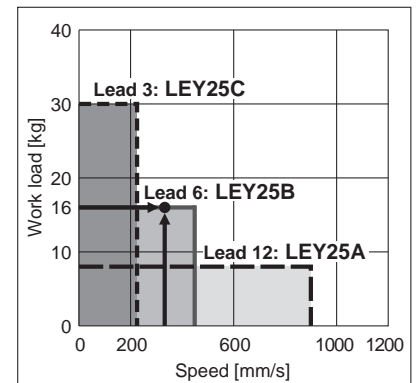

<Speed-Vertical Work Load Graph> (LEY25)

Step 1 Check the work load–speed. <Speed-Vertical Work Load Graph>

Select a model based on the workpiece mass and speed, within the range of the actuator specifications while referring to the “Speed-Work Load Graph (Guide)” on page 87.

Selection example) The **LEY25B** is provisionally selected based on the graph on the right.

* It is necessary to mount a guide outside the actuator when used for horizontal transfer. When selecting the target model, refer to pages 92 and 93 for the horizontal work load in the specifications, and page 120 for the precautions.

* Refer to the motor manufacturers catalogue for details of the regeneration resistance.

Step 2 Check the cycle time.

Calculate the cycle time using the following calculation method.

- Cycle time T can be found from the following equation.

$$T = T1 + T2 + T3 + T4 \text{ [s]}$$

- T1: Acceleration time and T3: Deceleration time can be found from the following equation.

$$T1 = V/a1 \text{ [s]} \quad T3 = V/a2 \text{ [s]}$$

- T2: Constant speed time can be found from the following equation.

$$T2 = \frac{L - 0.5 \cdot V \cdot (T1 + T3)}{V} \text{ [s]}$$

- T4: Settling time varies depending on the motor type and load. The value below is recommended.

$$T4 = 0.05 \text{ [s]}$$

* The conditions for the settling time vary depending on the motor or driver to be used.

Calculation example)

T1 to T4 can be calculated as follows.

$$T1 = V/a1 = 300/5000 = 0.06 \text{ [s]}, \quad T3 = V/a2 = 300/5000 = 0.06 \text{ [s]}$$

$$T2 = \frac{L - 0.5 \cdot V \cdot (T1 + T3)}{V} = \frac{300 - 0.5 \cdot 300 \cdot (0.06 + 0.06)}{300} = 0.94 \text{ [s]}$$

$$T4 = 0.05 \text{ [s]}$$

Therefore, the cycle time can be calculated as follows.

$$T = T1 + T2 + T3 + T4 = 0.06 + 0.94 + 0.06 + 0.05 = 1.11 \text{ [s]}$$

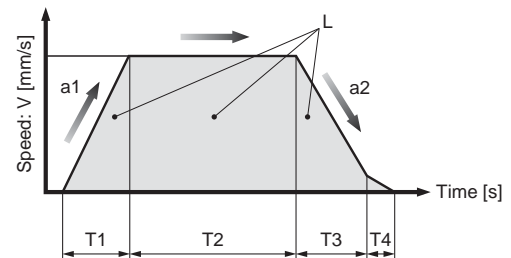

- L : Stroke [mm] (Operating condition)
- V : Speed [mm/s] (Operating condition)
- a1: Acceleration [mm/s²] ... (Operating condition)
- a2: Deceleration [mm/s²] ... (Operating condition)

T1: Acceleration time [s] ... Time until the set speed is reached

T2: Constant speed time [s] ... Time when the actuator is operating at a constant speed

T3: Deceleration time [s] ... Time from the constant speed operation until movement stops

T4: Settling time [s] ... Time until positioning is completed

Based on the above calculation result, the **LEY25B-300** can be selected.

Selection Procedure

Pushing Control Selection Procedure

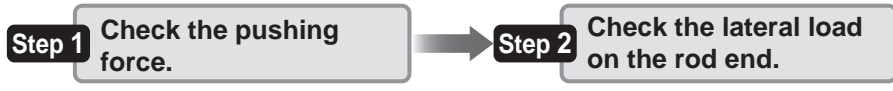

Selection Example

Operating conditions

- Mounting condition: Horizontal (pushing)
- Jig weight: 0.5 [kg]
- Pushing force: 255 [N]
- Speed: 100 [mm/s]
- Stroke: 300 [mm]

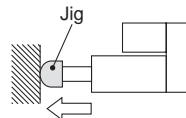

Step 1 Check the pushing force. <Force Conversion Graph>

Select the target model based on the "Ratio to rated torque" and pushing force with reference to the "Force Conversion Graph."

Selection example)

Based on the graph shown on the right,

- Ratio to rated torque: 30 [%]
- Pushing force: 255 [N]

Therefore, the **LEY25B** is provisionally selected.

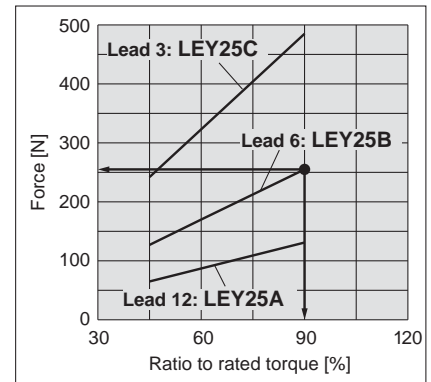

<Force Conversion Graph> (LEY25)

Step 2 Check the lateral load on the rod end.

<Graph of Allowable Lateral Load on the Rod End>

Confirm the allowable lateral load on the rod end of the actuator: LEY25B, which has been provisionally selected with reference to the "Graph of Allowable Lateral Load on the Rod End."

Selection example)

Based on the graph shown on the right,

- Jig weight: 0.5 [kg] ≈ 5 [N]
- Product stroke: 300 [mm]

Therefore, the lateral load on the rod end is within the allowable range.

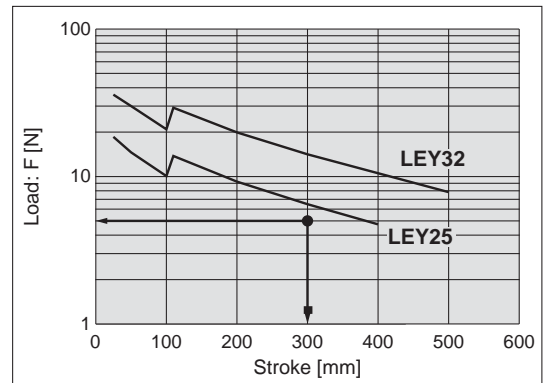

<Graph of Allowable Lateral Load on the Rod End>

Based on the above calculation result, the LEY25B-300 can be selected.

Model Selection

LEFS

LEFB

LEJS

LEY

LEYG

Motor Mounting

Series LEY

Motorless Type

Size 25, 32, 63

Speed-Vertical Work Load Graph

* The values given below are within the actuator body specification ranges and should not be exceeded.
 * The allowable speed is restricted depending on the stroke. Select it by referring to the "Allowable Stroke Speed."

LEY25□ (Motor mounting position: Top/Parallel, In-line)

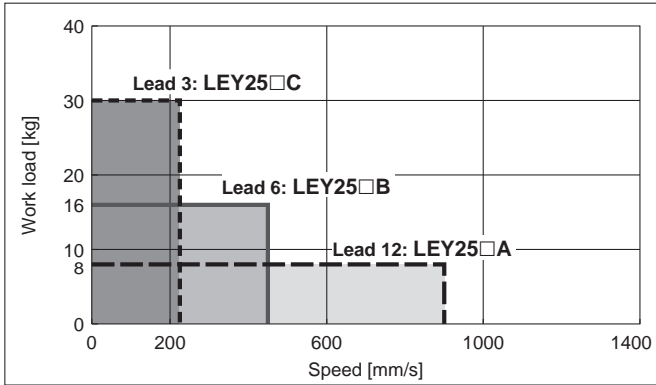

LEY32□ (Motor mounting position: Top/Parallel)

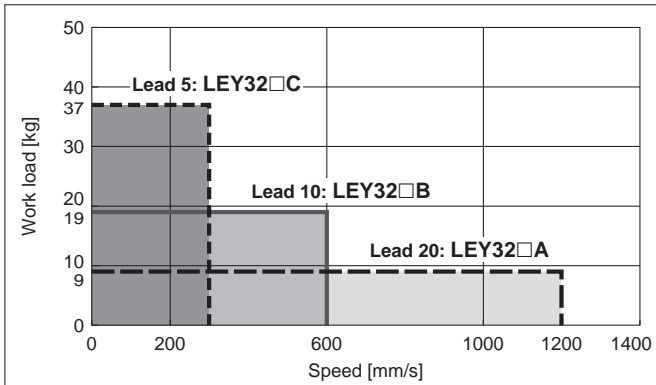

LEY32D (Motor mounting position: In-line)

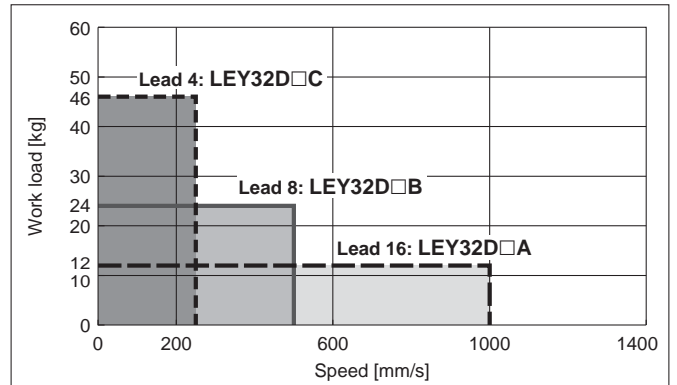

LEY63□ (Motor mounting position: Top/Parallel, In-line)

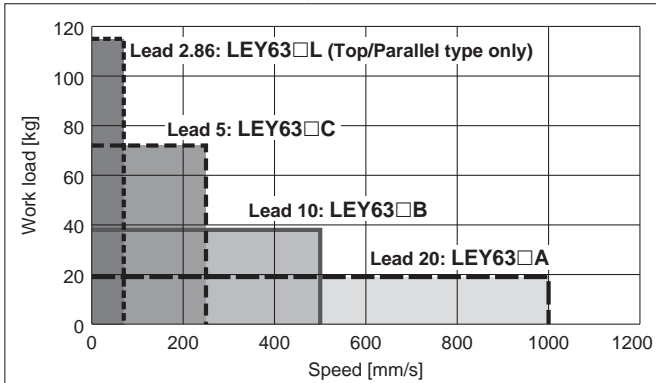

Speed–Horizontal Work Load Graph

* The values given below are within the actuator body specification ranges and should not be exceeded.
 * The allowable speed is restricted depending on the stroke. Select it by referring to the "Allowable Stroke Speed."

LEY25□ (Motor mounting position: Top/Parallel, In-line)

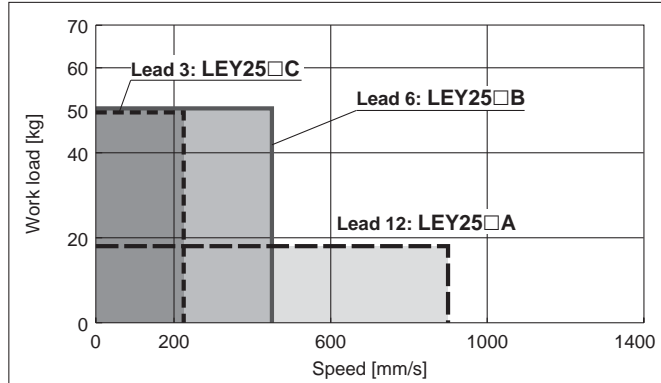

LEY32□ (Motor mounting position: Top/Parallel)

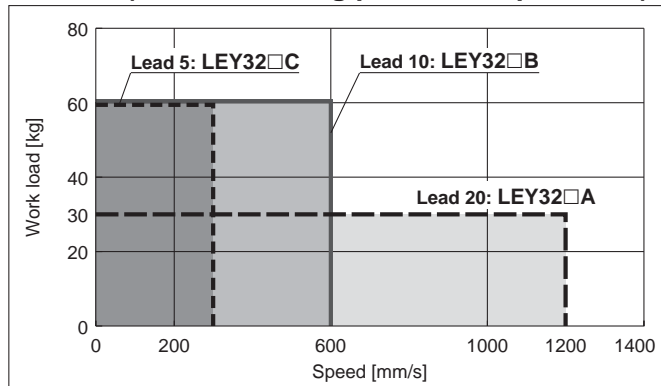

LEY32D (Motor mounting position: In-line)

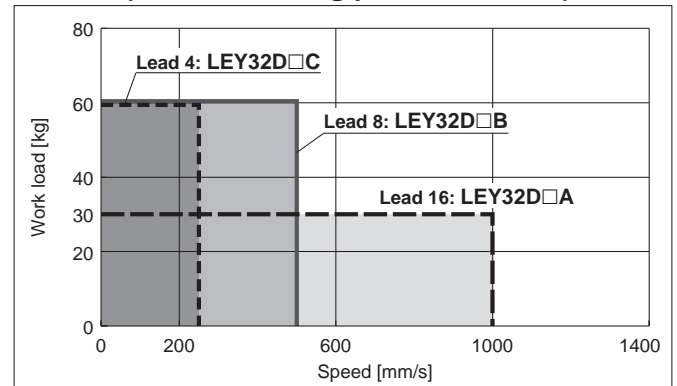

LEY63□ (Motor mounting position: Top/Parallel, In-line)

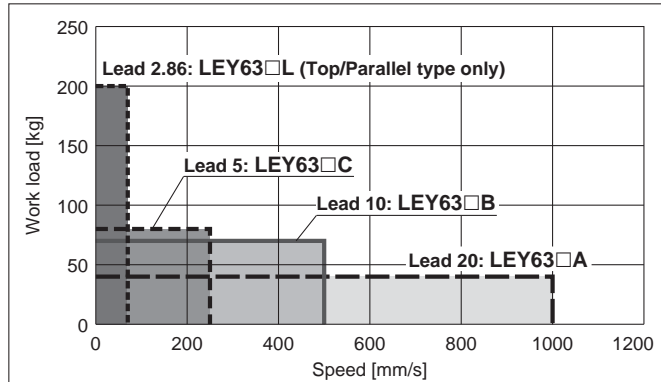

Allowable Stroke Speed

Model	Motor	Lead		Stroke [mm]							
		Symbol	[mm]	Up to 100	Up to 200	Up to 300	Up to 400	Up to 500	Up to 600	Up to 700	Up to 800
LEY25□ (Motor mounting position: Top/Parallel, In-line)	100 W equivalent	A	12		900		600	—	—	—	—
		B	6		450		300	—	—	—	—
		C	3		225		150	—	—	—	—
		(Motor rotation speed)			(4500 rpm)		(3000 rpm)	—	—	—	—
LEY32□ (Motor mounting position: Top/Parallel)	200 W equivalent	A	20		1200		800	—	—	—	—
		B	10		600		400	—	—	—	—
		C	5		300		200	—	—	—	—
		(Motor rotation speed)			(3600 rpm)		(2400 rpm)	—	—	—	—
LEY32D (Motor mounting position: In-line)	200 W equivalent	A	16		1000		640	—	—	—	—
		B	8		500		320	—	—	—	—
		C	4		250		160	—	—	—	—
		(Motor rotation speed)			(3750 rpm)		(2400 rpm)	—	—	—	—
LEY63□	400 W equivalent	A	20		1000		800	600	500		
		B	10		500		400	300	250		
		C	5		250		200	150	125		
		(Motor rotation speed)			(3000 rpm)		(2400 rpm)	(1800 rpm)	(1500 rpm)		
		L	2.86*		70						
(Motor rotation speed)			(1470 rpm)								

* Equivalent lead which includes a 5 mm screw lead and a pulley ratio of 4:7

Series LEY

Motorless Type

Size 25, 32, 63

Force Conversion Graph (Guide) * These graphs show an example of when the standard motor is mounted. Calculate the force based on the motor and driver used.

LEY25 (Motor mounting position: Top/Parallel, In-line)

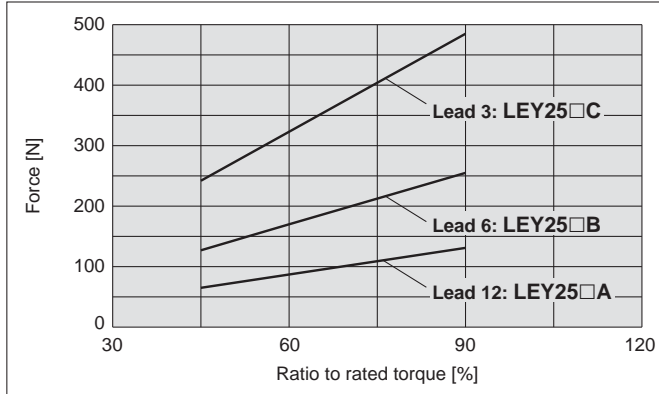

LEY32 (Motor mounting position: Top/Parallel)

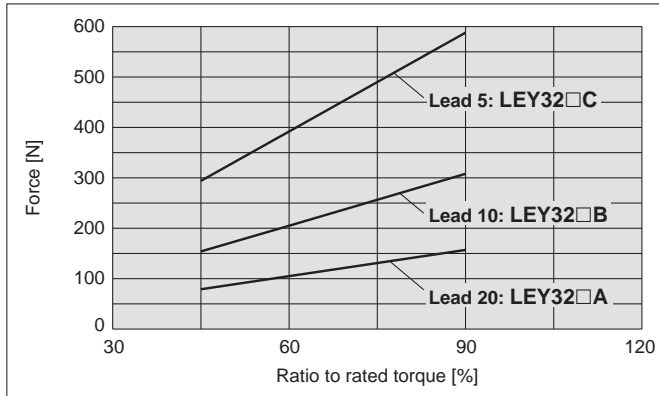

LEY32D (Motor mounting position: In-line)

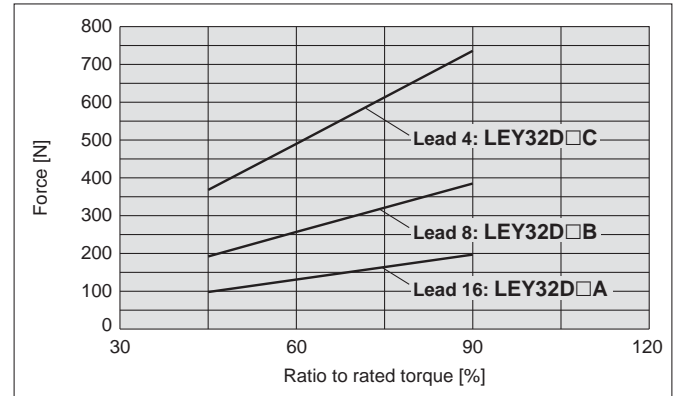

* When using the force control or speed control, set the maximum value to be less than 90 % of the rated torque.

LEY63 (Motor mounting position: Top/Parallel, In-line)

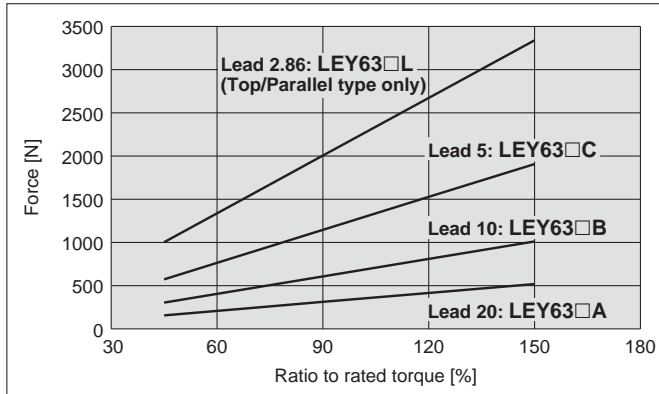

Graph of Allowable Lateral Load on the Rod End (Guide)

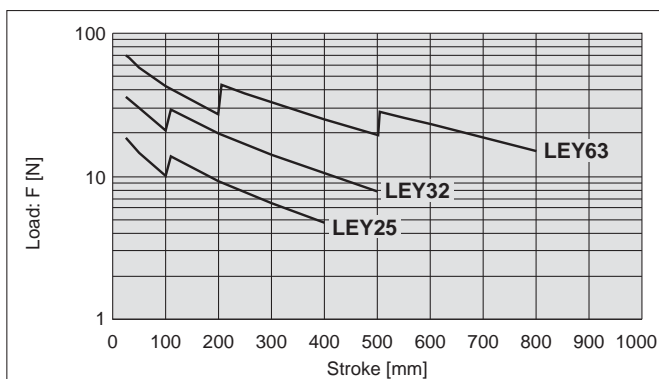

$$[\text{Stroke}] = [\text{Actuator stroke}] + [\text{Distance from the rod end to the centre of gravity of the workpiece}]$$

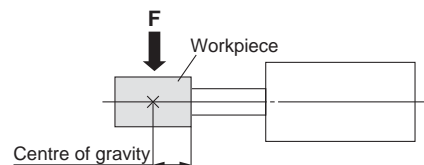

Motor Mounting	LEYG	LEY	LEJS	LEFB	LEFS	Model Selection
----------------	------	-----	------	------	------	-----------------

Electric Actuator/ Rod Type

Series **LEY** LEY25, 32, 63



How to Order

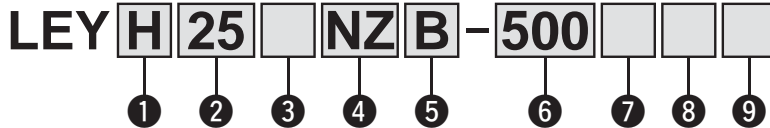

① Accuracy

—	Basic type
H	High precision type

② Size

25
32
63

④ Motor type

Symbol	Type
NZ	Fixation Z
NY	Fixation Y
NX	Fixation X
NW	Fixation W
NV	Fixation V
NU	Fixation U
NT	Fixation T
NM1	Fixation M1
NM2	Fixation M2

⑤ Lead [mm]

Symbol	LEY25	LEY32	LEY63
A	12	16 (20)	20
B	6	8 (10)	10
C	3	4 (5)	5
L	—	—	2.86*2

*1 The values shown in () are the lead for top mounting, right/left side parallel types. (Equivalent lead which includes the pulley ratio [1.25:1])

*2 Only available for top mounting and right/left side parallel types. (Equivalent lead which includes the pulley ratio [4:7])

⑥ Stroke [mm]

30	30
to	to
800	800

* Refer to the applicable stroke table.

③ Motor mounting position

—	Top mounting
R	Right side parallel
L	Left side parallel
D	In-line

⑦ Dust/Water-proof

Symbol	LEY25/32	LEY63
—	IP4x equivalent	IP5x equivalent (Dust-protected)
P	—	IP65 equivalent (Dust/Water-proof)/ With vent hole tap

* When using the dust/water-proof (IP65 equivalent), correctly mount the fitting and tubing to the vent hole tap, and then place the other end of the tubing in an area not exposed to dust or water.

* The fitting and tubing should be provided separately by the user. Select [Applicable tubing O.D.: Ø 4 or more, Connection thread: Rc 1/8].

* Cannot be used in environments exposed to cutting oil etc. Take suitable protective measures.

⑧ Rod end thread

—	Rod end female thread
M	Rod end male thread (1 rod end nut is included.)

⑨ Mounting*1

Symbol	Type	Motor mounting position	
		Top/Parallel	In-line
—	Ends tapped/ Body bottom tapped*2	●	●
L	Foot	●	—
F	Rod flange*2	●*4	●
G	Head flange*2	●*5	—
D	Double clevis*3	●	—

*1 Mounting bracket is shipped with the actuator, (but not assembled).

*2 For horizontal cantilever mounting with the ends tapped, rod flange and head flange, use the actuator within the following stroke range.

· LEY25: 200 mm or less, LEY32: 100 mm or less, LEY63: 400 mm or less

*3 For mounting with the double clevis, use the actuator within the following stroke range.

· LEY25: 200 mm or less, LEY32: 200 mm or less

*4 If the stroke of the LEY25 is "30 mm or less", the rod flange may interfere with the motor.

*5 Head flange is not applicable to the in-line type or the LEY32/63.

Applicable Stroke Table

Model	Stroke [mm]	●: Standard													
		30	50	100	150	200	250	300	350	400	450	500	600	700	800
LEY25		●	●	●	●	●	●	●	●	●	—	—	—	—	—
LEY32		●	●	●	●	●	●	●	●	●	●	—	—	—	—
LEY63		—	—	●	—	●	—	●	—	●	—	●	●	●	●

* Please consult with SMC for non-standard strokes as they are produced as special orders.

For auto switches, refer to pages 117 to 119.

Compatible Motors

Applicable motor model			Size/Motor type																						
Manufacturer	Series	Type	25						32						63										
			NZ Fixation Z	NY Fixation Y	NX Fixation X	NM1 Fixation M1	NM2 Fixation M2	NZ Fixation Z	NY Fixation Y	NX Fixation X	NW Fixation W	NV Fixation V	NU Fixation U	NT Fixation T	NM1 Fixation M1	NM2 Fixation M2	NZ Fixation Z	NY Fixation Y	NX Fixation X	NW Fixation W	NV Fixation V	NU Fixation U	NT Fixation T		
Mitsubishi Electric Corporation	MELSERVO-JN	HF-KN	●	—	—	—	—	●	—	—	—	—	—	—	—	—	—	—	—	—	—	—	—	—	—
	MELSERVO-J3	KF-KP	●	—	—	—	—	●	—	—	—	—	—	—	—	—	—	—	—	—	—	—	—	—	—
	MELSERVO-J4	HG-KR	●	—	—	—	—	●	—	—	—	—	—	—	—	—	—	—	—	—	—	—	—	—	—
YASKAWA Electric Corporation	Σ-V	SGMJV	●	—	—	—	—	●	—	—	—	—	—	—	—	—	—	—	—	—	—	—	—	—	—
SANYO DENKI CO., LTD.	SANMOTION R	R2	●	—	—	—	—	●	—	—	—	—	—	—	—	—	—	—	—	—	—	—	—	—	—
OMRON Corporation	Sysmac G5	R88M-K	●	—	—	—	—	●	—	—	—	—	—	—	—	—	—	—	—	—	—	—	—	—	—
Panasonic Corporation	MINAS-A4	MSMD	—	●	—	—	—	—	●	—	—	—	—	—	—	—	—	—	—	—	—	—	—	—	—
	MINAS-A5	MSMD/MHMD	—	●	—	—	—	—	●	—	—	—	—	—	—	—	—	—	—	—	—	—	—	—	—
FANUC CORPORATION	βis	β	●	—	—	—	—	● (β1 only)	—	—	●	—	—	—	—	—	—	—	—	● (β1 only)	—	—	—	—	—
NIDEC SANKYO CORPORATION	S-FLAG	MA/MH/MM	●	—	—	—	—	●	—	—	—	—	—	—	—	—	—	—	—	●	—	—	—	—	—
KEYENCE CORPORATION	SV	SV-M/SV-B	●	—	—	—	—	●	—	—	—	—	—	—	—	—	—	—	—	●	—	—	—	—	—
FUJI ELECTRIC CO., LTD.	ALPHA5	GYS/GYB	●	—	—	—	—	●	—	—	—	—	—	—	—	—	—	—	—	●	—	—	—	—	—
	FALDIC-α	GYS	●	—	—	—	—	●	—	—	—	—	—	—	—	—	—	—	—	●	—	—	—	—	—
ORIENTAL MOTOR Co., Ltd.	AR/AZ	AR/AZ	—	—	—	—	—	●	—	—	—	—	—	—	—	—	—	—	—	—	—	—	—	—	—
FASTECH Co., Ltd.	Ezi-SERVO	EzM	—	—	—	—	—	●	—	—	—	—	—	—	—	—	—	—	—	●	—	—	—	—	—
Rockwell Automation, Inc. (Allen-Bradley)	MP-/VP-	MP/VP	—	—	—	—	—	—	—	—	—	—	—	—	—	—	—	—	—	—	—	—	—	—	—
Beckhoff Automation GmbH	TL	TLY-A	●	—	—	—	—	—	—	—	—	—	—	—	—	—	—	—	—	—	—	—	—	—	—
	AM	AM30	●	—	—	—	—	—	—	—	—	—	—	—	—	—	—	—	—	—	—	—	—	—	—
	AM	AM31	●	—	—	—	—	—	—	—	—	—	—	—	—	—	—	—	—	—	—	—	—	—	—
Siemens AG	AM	AM80/AM81	●	—	—	—	—	—	—	—	—	—	—	—	—	—	—	—	—	—	—	—	—	—	—
	1FK7	1FK7	—	—	—	—	—	—	—	—	—	—	—	—	—	—	—	—	—	—	—	—	—	—	—
	1FK2	1FK2	●	—	—	—	—	—	●	—	—	—	—	—	—	—	—	—	—	—	—	—	—	—	—
Delta Electronics, Inc.	ASDA-A2	ECMA	●	—	—	—	—	—	●	—	—	—	—	—	—	—	—	—	—	—	—	—	—	—	

* Motor mounting position: In-line only

Specifications

• The values given below are within the actuator body specification range, with a standard motor mounted and should not be exceeded.

Model		LEY25 (Top/Parallel) LEY25D (In-line)				LEY32 (Top/Parallel)				LEY32D (In-line)			
Stroke [mm] ^{Note 1)}		30, 50, 100, 150, 200, 250 300, 350, 400				30, 50, 100, 150, 200, 250 300, 350, 400, 450, 500				30, 50, 100, 150, 200, 250 300, 350, 400, 450, 500			
Work load [kg]	^{Note 2)} Horizontal	18	50	50	30	60	60	30	60	60			
	Vertical	8	16	30	9	19	37	12	24	46			
Pushing force [N] ^{Note 3)} (Set value: Rated torque 45 to 90 %)		65 to 131	127 to 255	242 to 485	79 to 157	154 to 308	294 to 588	98 to 197	192 to 385	368 to 736			
Max. speed [mm/s] ^{Note 4)}	Stroke range	Up to 300	900	450	225	1200	600	300	1000	500	250		
		305 to 400	600	300	150								
		405 to 500	—	—	—								
Pushing speed [mm/s] ^{Note 5)}		35 or less				30 or less							
Max. acceleration/deceleration [mm/s ²]		5000											
Positioning repeatability [mm]	Basic type	±0.02											
	High precision type	±0.01											
Lost motion [mm] ^{Note 6)}	Basic type	0.1 or less											
	High precision type	0.05 or less											
Ball screw specifications	Thread size [mm]	Ø 10				Ø 12							
	Lead [mm] (including pulley ratio)	12	6	3	16 (20)	8 (10)	4 (5)	16	8	4			
	Shaft length [mm]	Stroke + 93.5				Stroke + 104.5							
Impact/Vibration resistance [m/s ²] ^{Note 7)}		50/20											
Actuation type		Ball screw + Belt (Top/Parallel) Ball screw (In-line)				Ball screw + Belt [Pulley ratio 1.25:1]				Ball screw			
Guide type		Sliding bushing (Piston rod)											
Operating temperature range [°C]		5 to 40											
Operating humidity range [%RH]		90 or less (No condensation)											
Actuation unit weight [kg] (*[ST]: Stroke)		0.15 + (0.69 × 10 ⁻³) × [ST]: 100 st or less 0.16 + (0.69 × 10 ⁻³) × [ST]: Over 100 st				0.24 + (1.40 × 10 ⁻³) × [ST]: 100 st or less 0.28 + (1.40 × 10 ⁻³) × [ST]: Over 100 st							
Other inertia [kg·cm ²]		0.012 (LEY25), 0.015 (LEY25D)				0.035 (LEY32), 0.061 (LEY32D)							
Coefficient of friction		0.05											
Mechanical efficiency		0.8											
Motor shape		□40				□60							
Motor type		AC servo motor											
Rated output capacity [W]		100				200							
Rated torque [N·m]		0.32				0.64							
Rated rotation [rpm]		3000											

Note 1) Please consult with SMC for non-standard strokes as they are produced as special orders.

Note 2) The maximum value of the horizontal work load. An external guide is necessary to support the load. The actual work load will vary according to the condition of the external guide. Confirm using actual device.

Note 3) The force setting range for the pushing operation (Speed control mode, Torque control mode).

The pushing force will vary according to the set value. Set it with reference to the "Force Conversion Graph (Guide)" on page 89.

Note 4) The allowable speed will vary according to the stroke.

Note 5) The allowable collision speed for the pushing operation.

Note 6) A reference value for correcting an error in reciprocal operation.

Note 7) Impact resistance: No malfunction occurred when the actuator was tested with a drop tester in both an axial direction and a perpendicular direction to the lead screw. (Test was performed with the actuator in the initial state.)

Vibration resistance: No malfunction occurred in a test ranging between 45 to 2000 Hz. Test was performed in both an axial direction and a perpendicular direction to the lead screw. (Test was performed with the actuator in the initial state.)

Note 8) The values are a guide only and should be used to select a motor capacity.

Weight

Product Weight

Series	LEY25 (Motor mounting position: Top/Parallel)										LEY32 (Motor mounting position: Top/Parallel)									
	Stroke [mm]	30	50	100	150	200	250	300	350	400	30	50	100	150	200	250	300	350	400	450
Weight [kg]	0.8	0.9	1.1	1.3	1.5	1.7	1.8	2.0	2.2	1.4	1.5	1.8	2.3	2.6	2.9	3.1	3.4	3.7	4.0	4.3

Series	LEY25D (Motor mounting position: In-line)										LEY32D (Motor mounting position: In-line)									
	Stroke [mm]	30	50	100	150	200	250	300	350	400	30	50	100	150	200	250	300	350	400	450
Weight [kg]	0.8	0.9	1.1	1.3	1.5	1.7	1.9	2.0	2.2	1.4	1.6	1.8	2.3	2.6	2.9	3.2	3.4	3.7	4.0	4.3

Additional Weight

Size		25	32
Rod end male thread	Male thread	0.03	0.03
	Nut	0.02	0.02
Foot (2 sets including mounting screw)		0.08	0.14
Rod flange (including mounting screw)		0.17	0.20
Head flange (including mounting screw)			
Double clevis (including pin, retaining ring and mounting screw)		0.16	0.22

Model Selection
LEFS
LEFB
LEJS
LEY
Motor Mounting

Specifications

• The values given below are within the actuator body specification range, with a standard motor mounted and should not be exceeded.

Model		LEY63D (In-line)							LEY63 (Top/Parallel)										
Stroke [mm] ^{Note 1)}		100, 200, 300, 400, 500, 600, 700, 800																	
Work load [kg]		^{Note 2)} Horizontal		40	70	80	40	70	80	200	^{Note 2)} Vertical		19	38	72	19	38	72	115
		Pushing force [N] ^{Note 3)} (Set value: Rated torque 45 to 150 %)		156 to 521	304 to 1012	573 to 1910	156 to 521	304 to 1012	573 to 1910	1003 to 3343									
^{Note 4)} Max. speed [mm/s]	Stroke range	Up to 500	1000	500	250	1000	500	250	70										
		505 to 600	800	400	200	800	400	200											
		605 to 700	600	300	150	600	300	150											
		705 to 800	500	250	125	500	250	125											
Pushing speed [mm/s] ^{Note 5)}		30 or less																	
Max. acceleration/deceleration [mm/s ²]		5000																	
Positioning repeatability [mm]		Basic type		±0.02															
		High precision type		±0.01															
Lost motion [mm] ^{Note 6)}		Basic type		0.1 or less															
		High precision type		0.05 or less															
Ball screw specifications		Thread size [mm]		Ø 20															
		Lead [mm]		20	10	5	20	10	5	5 (2.86)									
		Shaft length [mm]		Stroke + 147															
Impact/Vibration resistance [m/s ²] ^{Note 7)}		50/20																	
Actuation type		Ball screw							Ball screw + Belt [Pulley ratio 1:1]							Ball screw + Belt [Pulley ratio 4:7]			
Guide type		Sliding bushing (Piston rod)																	
Operating temperature range [°C]		5 to 40																	
Operating humidity range [%RH]		90 or less (No condensation)																	
Actuation unit weight [kg] (*[ST]: Stroke)		0.84 + (2.77 × 10 ⁻³) × [ST]: 200 st or less																	
		0.94 + (2.77 × 10 ⁻³) × [ST]: Over 200 st, 500 st or less																	
		1.03 + (2.77 × 10 ⁻³) × [ST]: Over 500 st																	
Other inertia [kg-cm ²]		0.056 (LEY63D)							0.110							0.053			
Coefficient of friction		0.05																	
Mechanical efficiency ^{Note 8)}		0.8																	
Motor shape		□60																	
Motor type		AC servo motor																	
Rated output capacity [W]		400																	
Rated torque [N-m]		1.27																	
Rated rotation [rpm]		3000																	

Note 1) Please consult with SMC for non-standard strokes as they are produced as special orders.

Note 2) The maximum value of the horizontal work load. An external guide is necessary to support the load. The actual work load will vary according to the condition of the external guide. Confirm using actual device.

Note 3) The force setting range for the pushing operation (Speed control mode, Torque control mode).

The pushing force will vary according to the set value. Set it with reference to the "Force Conversion Graph (Guide)" on page 89.

Note 4) The allowable speed will vary according to the stroke.

Note 5) The allowable collision speed for the pushing operation.

Note 6) A reference value for correcting an error in reciprocal operation.

Note 7) Impact resistance: No malfunction occurred when the actuator was tested with a drop tester in both an axial direction and a perpendicular direction to the lead screw. (Test was performed with the actuator in the initial state.)

Vibration resistance: No malfunction occurred in a test ranging between 45 to 2000 Hz. Test was performed in both an axial direction and a perpendicular direction to the lead screw. (Test was performed with the actuator in the initial state.)

Note 8) The values are a guide only and should be used to select a motor capacity.

Weight

Product Weight

Model	LEY63D (Motor mounting position: In-line)								LEY63 (Motor mounting position: Top/Parallel)							
Stroke [mm]	100	200	300	400	500	600	700	800	100	200	300	400	500	600	700	800
Weight [kg]	4.2	5.3	7.0	8.2	9.3	11.0	12.1	13.3	4.0	5.2	6.9	8.0	9.1	10.8	12.0	13.1

Additional Weight

[kg]

Size		63
Rod end male thread	Male thread	0.12
	Nut	0.04
Rod flange (including mounting screw)		0.51
Foot (2 sets including mounting screw)		0.26
Double clevis (including pin, retaining ring and mounting screw)		0.58

Refer to the "Motor Mounting" on pages 109 and 111 for details of motor mounting and parts included.

Dimensions: Motor Top/Parallel

LEY25, 32, 63

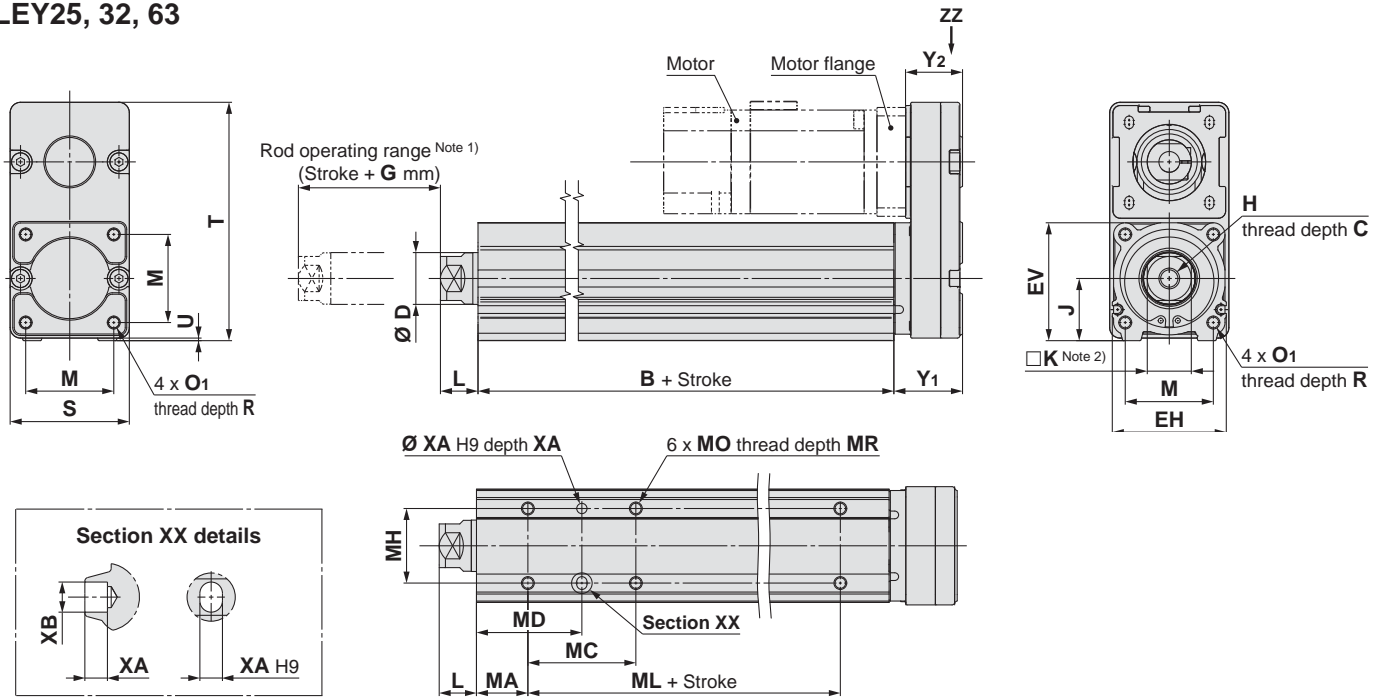

Note 1) Do not allow collisions at either end of the rod operating range at a speed exceeding the "pushing speed." Additionally, when running the positioning operation, do not set within 2 mm of either end for size 25, 32, and do not set within 4 mm of either end for size 63.

Note 2) The direction of rod end width across flats (□K) differs depending on the products.

IP65 equivalent (Dust-tight/Water proof): LEY63□□□□-□P (View ZZ)

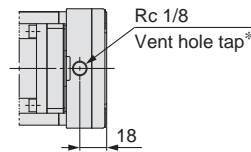

* When using the dust/water-proof (IP 6 5 equivalent), correctly mount the fitting and tubing to the vent hole tap, and then place the other end of the tubing in an area not exposed to dust or water. The fitting and tubing should be provided separately by the user. Select [Applicable tubing O.D.: Ø 4 or more, Connection thread: Rc 1/8].

Dimensions

Size	Stroke range [mm]	B	C	D	EH	EV	H	J	K	L	M	O ₁	R	S	T	U	Y ₁	Y ₂	G
25	15 to 100	89.5	13	20	44	45.5	M8 x 1.25	24	17	12.5	34	M5 x 0.8	8	46	92	1	26.5	22	4
	105 to 400	114.5																	
32	20 to 100	96	13	25	51	56.5	M8 x 1.25	31	22	16.5	40	M6 x 1.0	10	60	118	1	34	27	4
	105 to 500	126																	
63	Up to 200	123	21	40	76	82	M16 x 2	44	36	33.4	60	M8 x 1.25	16	80	146	4	32.2	29	8
	205 to 500	158																	
	505 to 800	193																	

* The L measurement is when the unit is at the retracted stroke end position.

Size	Stroke range [mm]	MA	MC	MD	MH	ML	MO	MR	XA	XB
25	15 to 39	20	24	32	29	50	M5 x 0.8	6.5	4	5
	40 to 100		42	41						
	101 to 124		59	49.5						
	125 to 200		76	58						
	201 to 400		72	36						
32	20 to 39	25	36	43	30	50	M6 x 1	8.5	5	6
	40 to 100		53	51.5						
	101 to 124		70	60						
	125 to 200		76	60						
63	50 to 70	38	24	50	44	65	M8 x 1.25	10	6	7
	75 to 120		45	60.5						
	125 to 200		58	67						
	205 to 500		86	81						
	505 to 800		100	135						

Model Selection
LEFS
LEFB
LEJS
LEY
LEYG
Motor Mounting

Series LEY

Motorless Type

Size 25, 32, 63

Refer to the "Motor Mounting" on pages 109 and 111 for details of motor mounting and parts included.

Dimensions: Motor Top/Parallel

Motor flange dimensions

LEY25: NM1, NM2

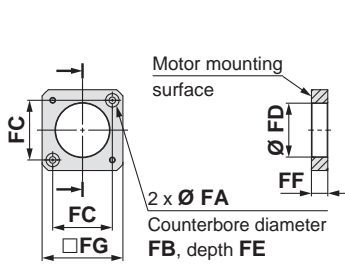

LEY32: NM1, NM2

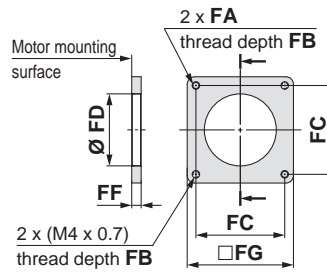

LEY25: NZ, NY, NX

LEY32: NZ, NY, NW, NU, NT

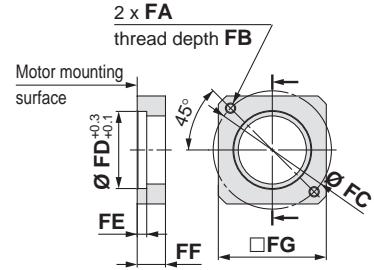

Dimensions

[mm]

Size	Motor type	FA	FB	FC	FD	FE	FF	FG
25	NZ	M4 x 0.7	7.5	46	30	3.7	11	42
	NY	M3 x 0.5	5.5	45	30	5	11	38
	NX	M4 x 0.7	7	46	30	3.7	8	42
	NM1, NM2	∅3.4	7	31	28	3.5	8.5	42
32	NZ, NW, NU	M5 x 0.8	8.5	70	50	4.6	13	60
	NY	M4 x 0.7	7	70	50	4.6	13	60
	NT	M5 x 0.8	8.5	70	50	4.6	17	60
	NM1	M4 x 0.7	(5)	47.1	38.2	—	5	56.4
63	NM2	M4 x 0.7	8	50	38.2	—	11.5	60
	NZ, NW	M5 x 0.8	8.5	70	50	4.6	11	60
	NY	M4 x 0.7	8	70	50	4.6	11	60
	NT	M5 x 0.8	8.5	70	50	4.6	14.5	60

LEY63: NZ, NY, NW, NT

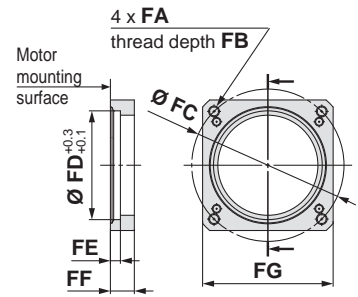

Motor left side parallel type: LEY32L
25
63

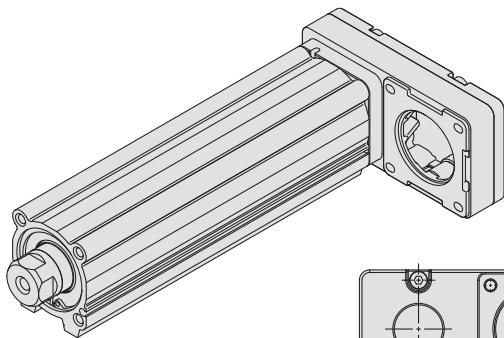

Size	S1	T2	U
25	47	91	1
32	61	117	1
63	84	142	4

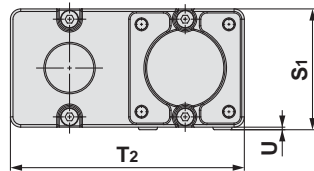

Motor right side parallel type: LEY32R
25
63

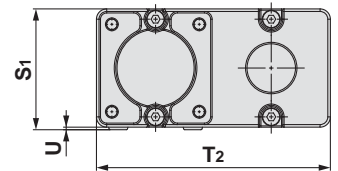
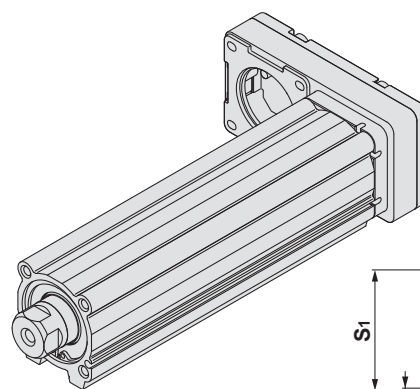

Note) When the motor is mounted on the left or right side in parallel, the groove for auto switch on the side to which the motor is mounted is hidden.

Refer to the "Motor Mounting" on page 110 for details of motor mounting and parts included.

Dimensions: In-line Motor

LEY25, 32

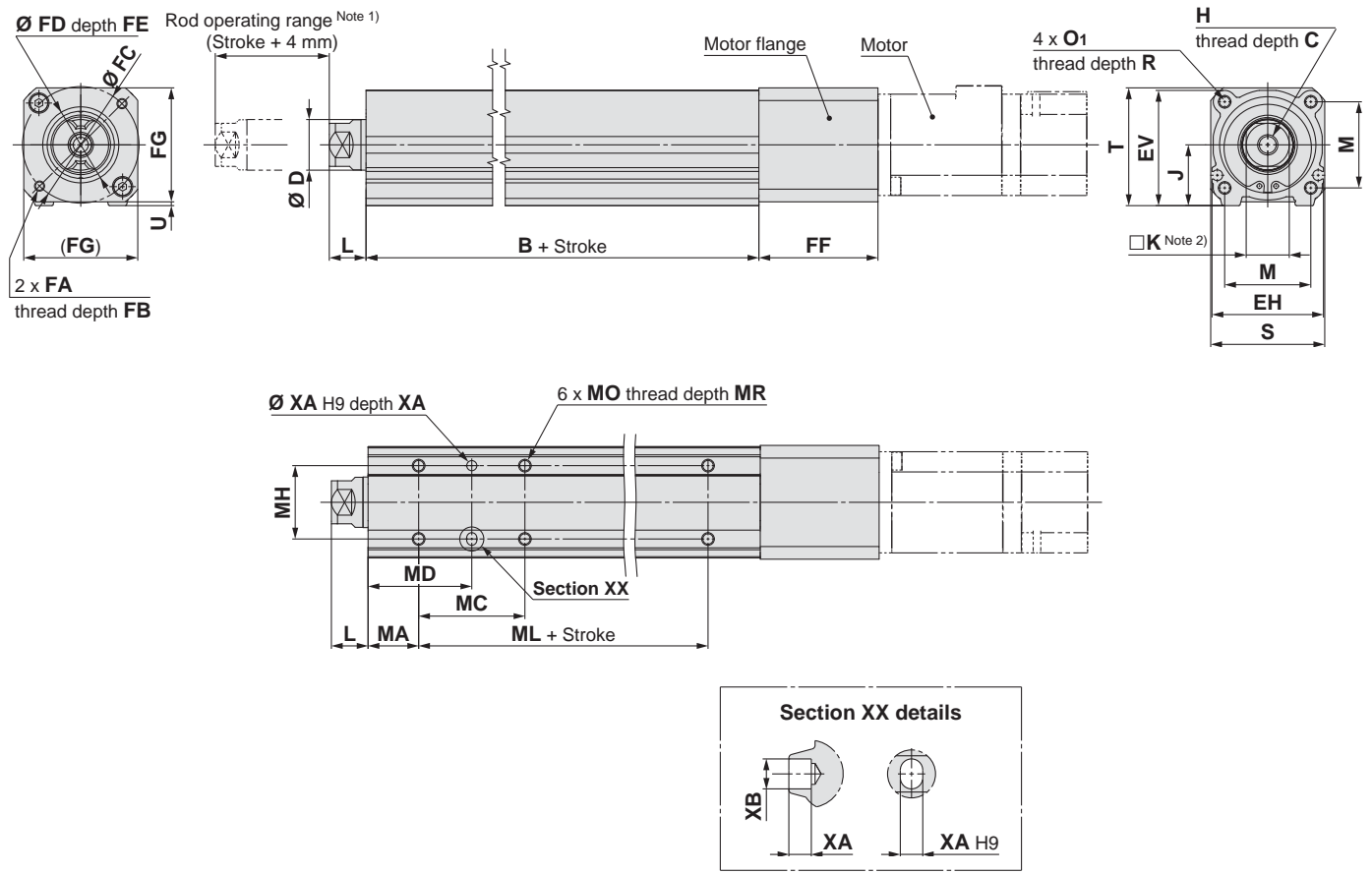

Note 1) Do not allow collisions at either end of the rod operating range at a speed exceeding the "pushing speed."
 Additionally, when running the positioning operation, do not set within 2 mm of either end.
 Note 2) The direction of rod end width across flats (□K) differs depending on the products.

Dimensions

Size	Stroke range [mm]	B	C	D	EH	EV	H	J	K	L	M	O ₁	R	S	T	U
25	15 to 100	89.5	13	20	44	45.5	M8 x 1.25	24	17	12.5	34	M5 x 0.8	8	45	46.5	1.5
	105 to 400	114.5														
32	20 to 100	96	13	25	51	56.5	M8 x 1.25	31	22	16.5	40	M6 x 1.0	10	60	61	1
	105 to 500	126														

* The L measurement is when the unit is at the retracted stroke end position.

Size	Stroke range [mm]	MA	MC	MD	MH	ML	MO	MR	XA	XB
25	15 to 35	20	24	32	29	50	M5 x 0.8	6.5	4	5
	40 to 100		42	41						
	105 to 120		59	49.5		75				
	125 to 200		76	58						
	205 to 400		76	58						
32	20 to 35	25	22	36	30	50	M6 x 1.0	8.5	5	6
	40 to 100		36	43						
	105 to 120		53	51.5		80				
	125 to 200		70	60						
	205 to 500		70	60						

Model Selection

LEFS

LEFB

LEJS

LEY

LEYG

Motor Mounting

Series LEY

Motorless Type

Size 25, 32

Refer to the "Motor Mounting" on page 110 for details of motor mounting and parts included.

Dimensions: In-line Motor

LEY25: NM1, NM2

LEY32: NM1

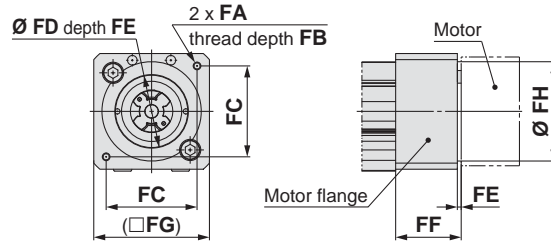
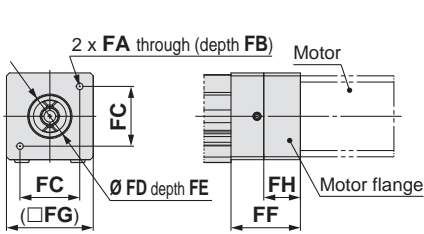

LEY32: NM2

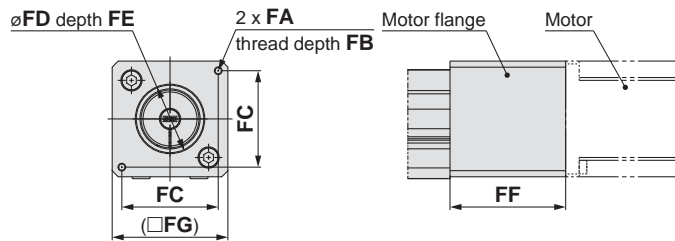

Dimensions

[mm]

Size	Motor type	FA	FB	FC	FD	FE	FF	FG	FH
25	NZ, NX	M4 x 0.7	7.5	46	30	3.7	47	45	—
	NY	M3 x 0.5	6	45	30	4.2	47	45	—
	NM1	ø3.4	17	31	22	2.5	36	45	19
	NM2	ø3.4	28	31	30	3.5	56	45	30
32	NZ, NW, NU, NT	M5 x 0.8	8.5	70	50	3.3	60	60	—
	NY	M4 x 0.7	8	70	50	3.3	60	60	—
	NX	M5 x 0.8	8.5	63	40	3.5	63	60	—
	NV	M4 x 0.7	8	63	40	3.5	63	60	—
	NM1	M4 x 0.7	8	47.14	38.1	2	34	60	51.5
	NM2	M4 x 0.7	8	50	36	3.3	60	60	—

Refer to the "Motor Mounting" on page 112 for details of motor mounting and parts included.

Dimensions: In-line Motor

LEY63

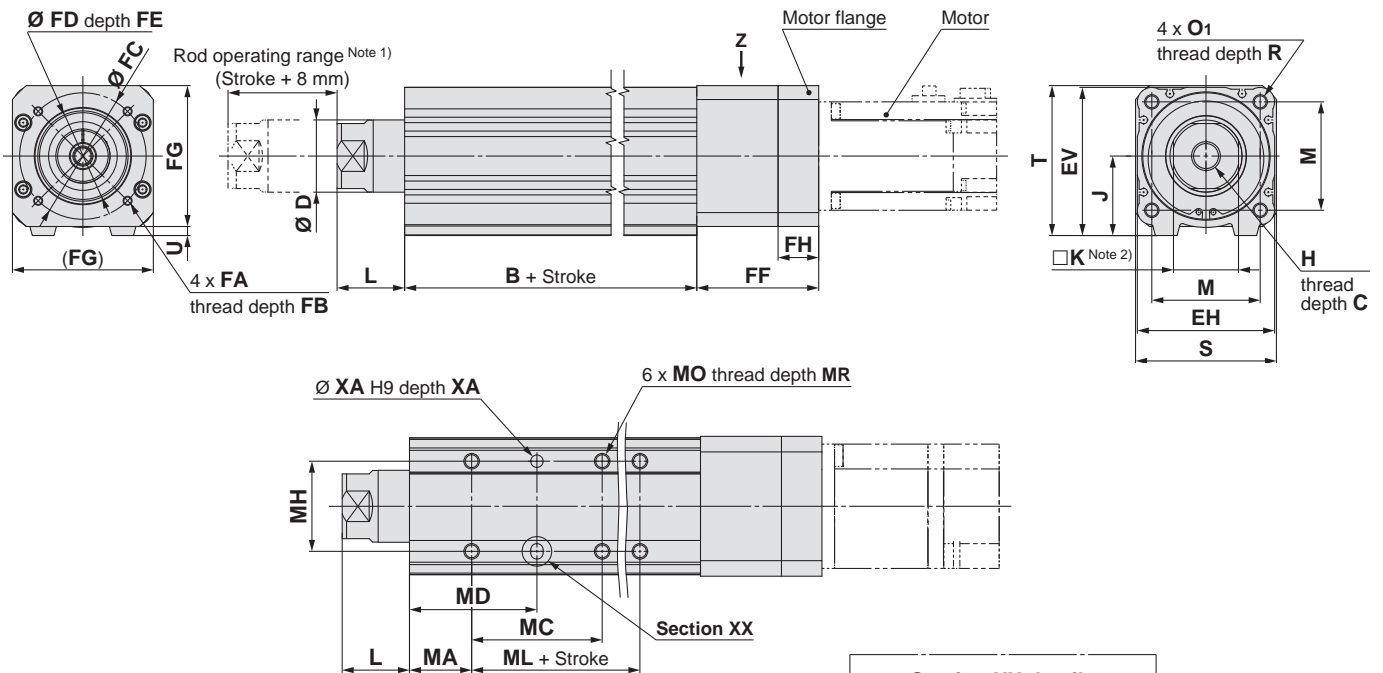

Note 1) Do not allow collisions at either end of the rod operating range at a speed exceeding the "pushing speed." Additionally, when running the positioning operation, do not set within 4 mm of either end.

Note 2) The direction of rod end width across flats (□K) differs depending on the products.

IP65 equivalent (Dust-tight/Water-jet-proof): LEY63DN□□-□P (View Z)

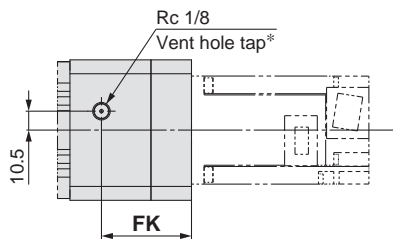

* When using the dust/water-proof (IP65 equivalent), correctly mount the fitting and tubing to the vent hole tap, and then place the other end of the tubing in an area not exposed to dust or water. The fitting and tubing should be provided separately by the user. [Applicable tubing O.D.: Ø 4 or more, Connection thread: Rc 1/8].

Dimensions

Size	Stroke range [mm]	B	C	D	EH	EV	H	J	K	L	M	O ₁	R	S	T	U
63	50 to 200	123	21	40	76	82	M16 x 2	44	36	33.4	60	M8 x 1.25	16	78	83	5
	205 to 500	158														
	505 to 800	193														

* The L measurement is when the unit is at the retracted stroke end position.

Size	Stroke range [mm]	MA	MC	MD	MH	ML	MO	MR	XA	XB	
63	50 to 70	38	24	50	44	65	M8 x 1.25	10	6	7	
	75 to 120		45	60.5							
	125 to 200		58	67							
	205 to 500		86	81							100
	505 to 800										135

Size	Motor type	FA	FB	FC	FD	FE	FF	FG	FH	FK
63	NZ, NW, NU, NT	M5 x 0.8	10	70	50	3.5	67.7	78	22.5	50
	NY	M4 x 0.7	8	70	50	3.5	67.7	78	22.5	50
	NX	M5 x 0.8	10	63	40	3.5	72.7	78	27.5	55
	NV	M4 x 0.7	10	63	40	3.5	72.7	78	27.5	55

Series LEY

Motorless Type

Size **25, 32, 63**

Dimensions

End male thread: LEY32□□B-□□M
 25 A
 63 C

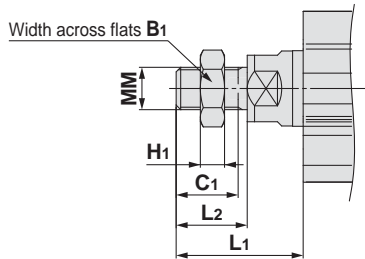

* Refer to the **SMC website** or the specific catalogue for details about the rod end nut and mounting bracket.

Note) Refer to the precautions on pages 121 and 122 when mounting end brackets such as knuckle joint or workpieces.

Size	B1	C1	H1	L1	L2	MM
25	22	20.5	8	36	23.5	M14 x 1.5
32	22	20.5	8	40	23.5	M14 x 1.5
63	27	26	11	72.4	39	M18 x 1.5

* The L1 measurement is when the unit is at the retracted stroke end position.

Foot: LEY32□□B-□□□L
 25 A
 63 C

Included parts
 · Foot
 · Body mounting screw

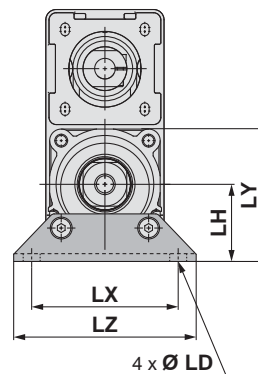
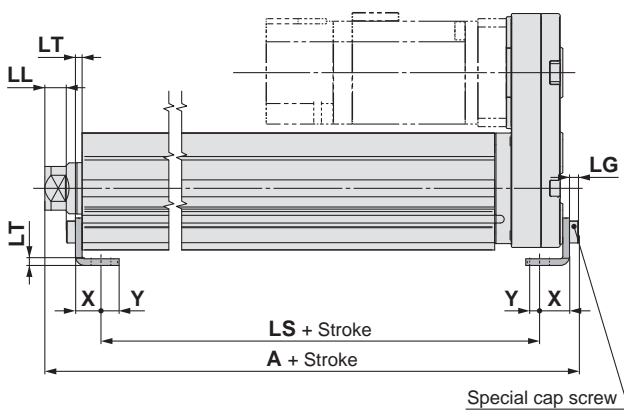

Outward mounting

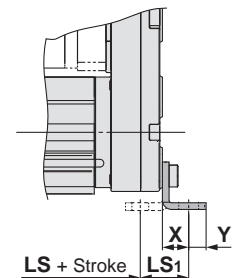

Foot

Size	Stroke range [mm]	A	LS	LS ₁	LL	LD	LG	LH	LT	LX	LY	LZ	X	Y
25	15 to 100	134.6	98.8	19.8	6.4	6.6	3.5	30	2.6	57	51.5	71	11.2	5.8
	105 to 400	159.6	123.8											
32	20 to 100	153.7	114	19.2	9.3	6.6	4	36	3.2	76	61.5	90	11.2	7
	105 to 500	183.7	144											
63	50 to 200	196.8	133.2	25.2	25.2	9	5	50	3.2	95	88	110	14.2	8
	205 to 500	231.8	168.2											
	505 to 800	266.8	203.2											

Material: Carbon steel (Chromated)

* The A and LL measurements are when the unit is at the retracted stroke end position.

Note) When the motor mounting is the right or left side parallel type, the head end foot should be mounted outward.

Dimensions

Rod flange: LEY32□□B-□□□F
25 A
63 C

Head flange: LEY25□□B-□□□G
A
C

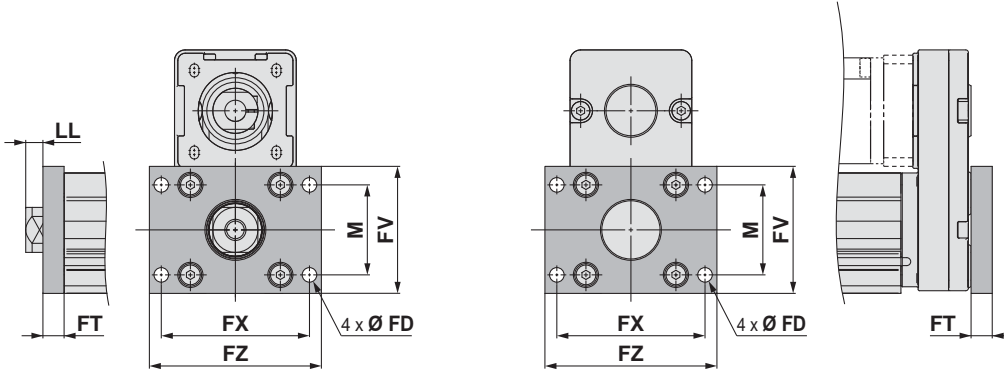

* Head flange is not applicable to the in-line type or the LEY32/63.

- Included parts
- Flange
 - Body mounting screw

Rod/Head Flange [mm]

Size	FD	FT	FV	FX	FZ	LL	M
25	5.5	8	48	56	65	4.5	34
32	5.5	8	54	62	72	8.5	40
63	9	9	80	92	108	24.4	60

Material: Carbon steel (Nickel plating)

* The LL measurement is when the unit is at the retracted stroke end position.

Double clevis: LEY32□□B-□□□□D
25 A
63 C

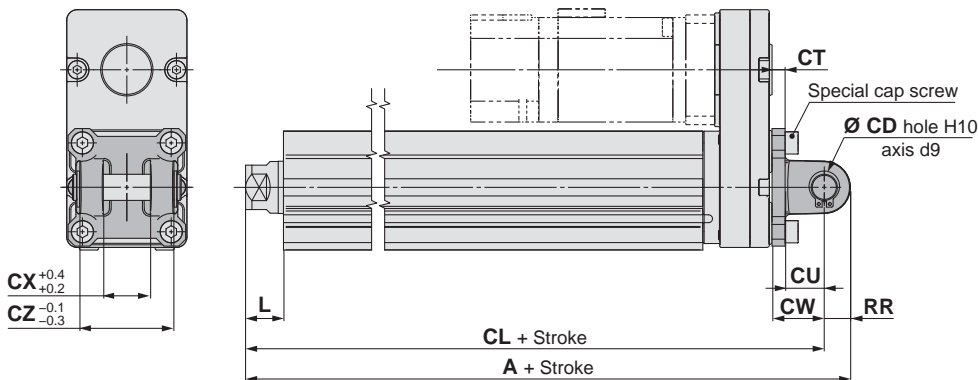

- Included parts
- Double clevis
 - Body mounting screw
 - Clevis pin
 - Retaining ring

* Refer to the **SMC website** or the specific catalogue for details about the rod end nut and mounting bracket.

Double Clevis [mm]

Size	Stroke range [mm]	A	CL	CD	CT	CU	CW	CX	CZ	L	RR
25	15 to 100	158.5	148.5	10	5	14	20	18	36	12.5	10
	105 to 200	183.5	173.5								
32	20 to 100	178.5	168.5	10	6	14	22	18	36	16.5	10
	105 to 200	208.5	198.5								
63	50 to 200	232.6	218.6	14	8	22	30	22	44	33.4	14
	205 to 300	267.6	253.6								

Material: Cast iron (Coating)

* The A, CL and L measurements are when the unit is at the retracted stroke end position.

Model Selection

LEFS

LEFB

LEJS

LEY

LEYG

Motor Mounting

Model Selection



Moment Load Graph

Selection Conditions

Mounting orientation	Vertical	Horizontal	
Max. speed [mm/s]	"Speed-Vertical Work Load Graph"	200 or less	Over 200
Graph (Sliding bearing type)	①, ②	⑤, ⑥*	⑦, ⑧
Graph (Ball bushing bearing type)	③, ④	⑨, ⑩	⑪, ⑫

* For the sliding bearing type, the speed is restricted with a horizontal/moment load.

Vertical Mounting, Sliding Bearing

① 70 mm stroke or less

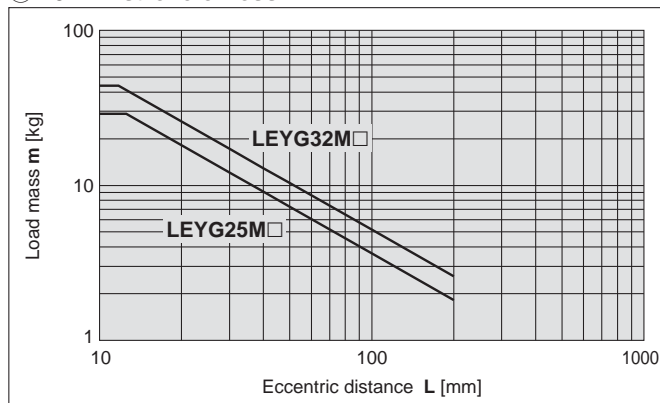

* The limit of vertical load mass varies depending on "lead" and "speed."
Check the "Speed-Vertical Work Load Graph" on page 103.

② Over 75 mm stroke

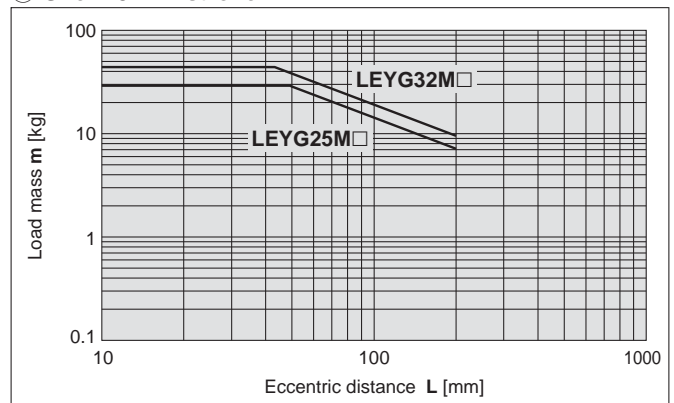

Vertical Mounting, Ball Bushing Bearing

③ 35 mm stroke or less

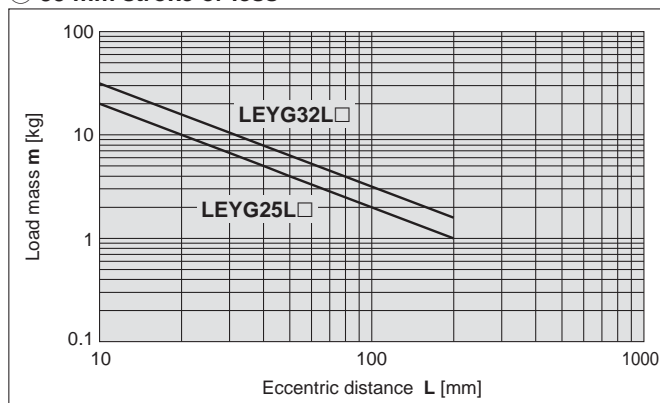

* The limit of vertical load mass varies depending on "lead" and "speed."
Check the "Speed-Vertical Work Load Graph" on page 103.

④ Over 40 mm stroke

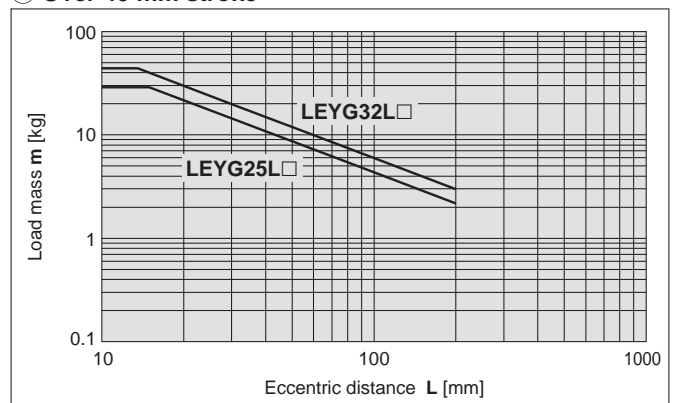

Moment Load Graph

Horizontal Mounting, Sliding Bearing

⑤ L = 50 mm Max. speed = 200 mm/s or less

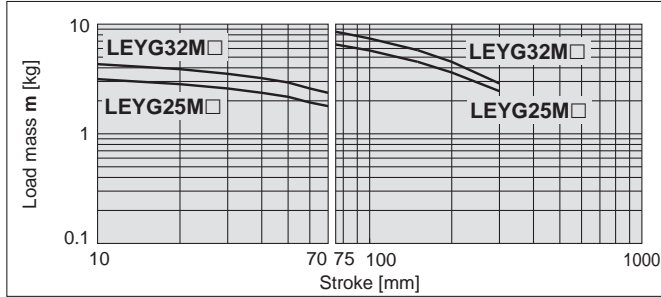

⑥ L = 100 mm Max. speed = 200 mm/s or less

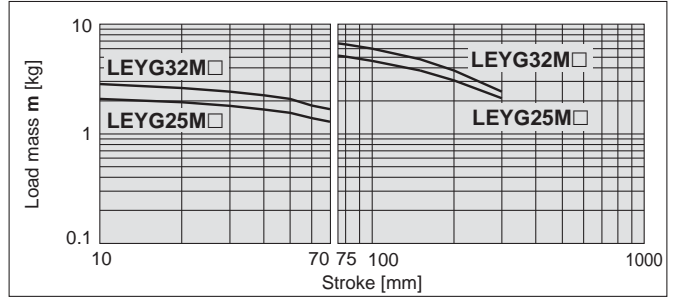

⑦ L = 50 mm Max. speed = Over 200 mm/s

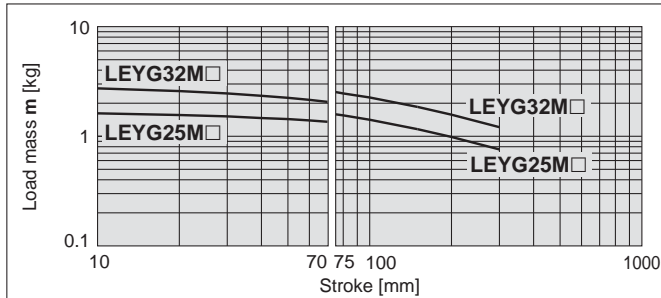

⑧ L = 100 mm Max. speed = Over 200 mm/s

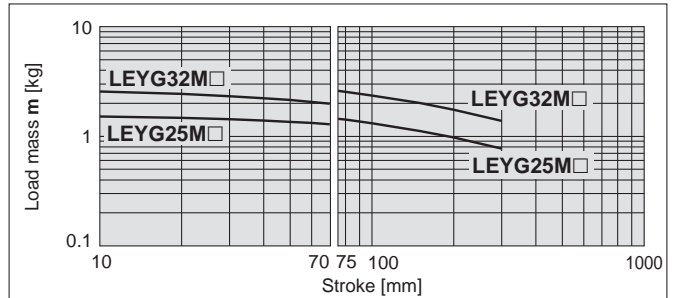

Horizontal Mounting, Ball Bushing Bearing

⑨ L = 50 mm Max. speed = 200 mm/s or less

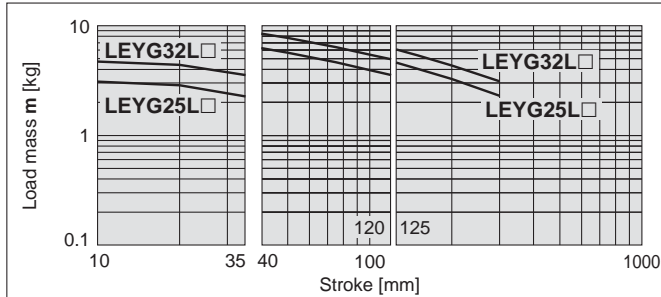

⑩ L = 100 mm Max. speed = 200 mm/s or less

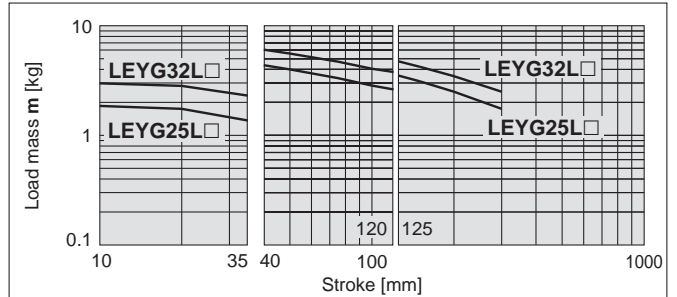

⑪ L = 50 mm Max. speed = Over 200 mm/s

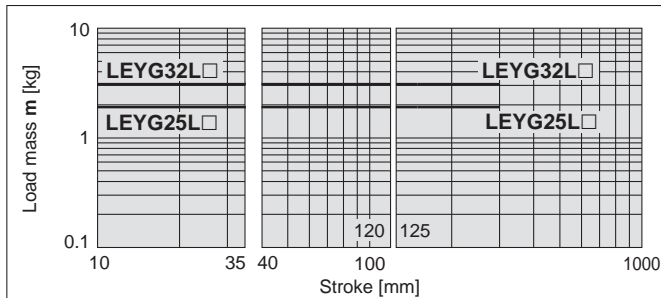

⑫ L = 100 mm Max. speed = Over 200 mm/s

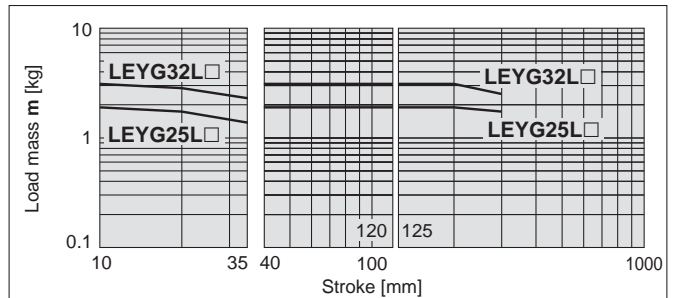

Operating Range when Used as Stopper

LEYG□M (Sliding bearing)

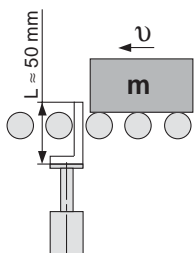

⚠ Caution

Handling Precautions

- Note 1) When used as a stopper, select a model with 30 mm stroke or less.
- Note 2) LEYG□L (ball bushing bearing) cannot be used as a stopper.
- Note 3) Workpiece collision in series with guide rod cannot be permitted (Fig. a).
- Note 4) The body should not be mounted on the end. It must be mounted on the top or bottom (Fig. b).

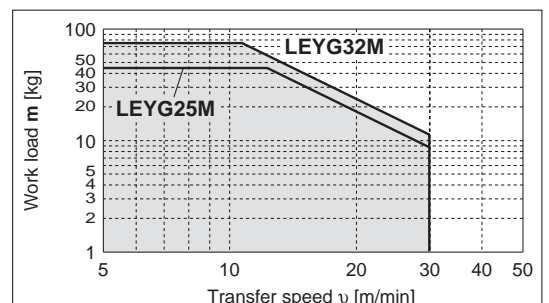
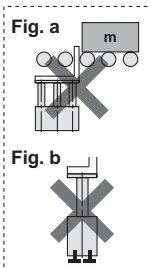

Series LEYG

Motorless Type

* These graphs show the work load when the external guide is used together. When using the LEYG alone, refer to pages 101 and 102.
 * The values show below are allowable values of the actuator body. Do not use the actuator so that it exceeds these specification ranges.

Speed-Vertical Work Load Graph

LEYG25□ (Motor mounting position: Top mounting/In-line)

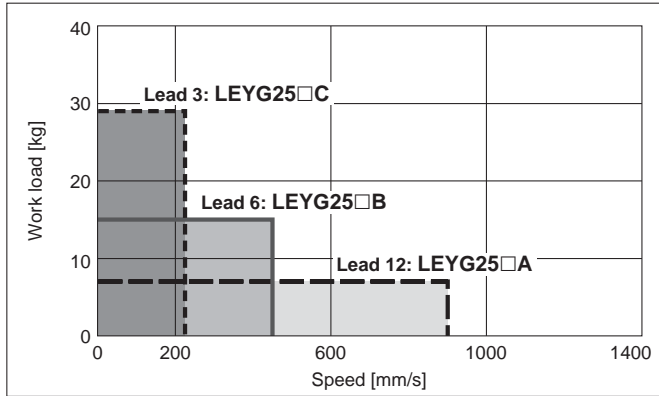

LEYG32□ (Motor mounting position: Top mounting)

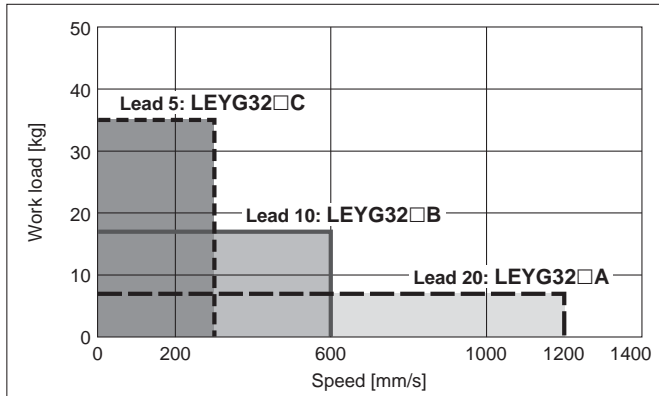

LEYG32D (Motor mounting position: In-line)

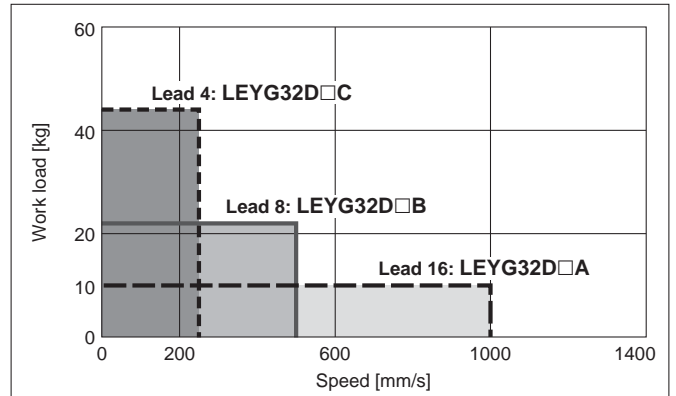

Speed-Horizontal Work Load Graph

LEYG25□ (Motor mounting position: Top mounting/In-line)

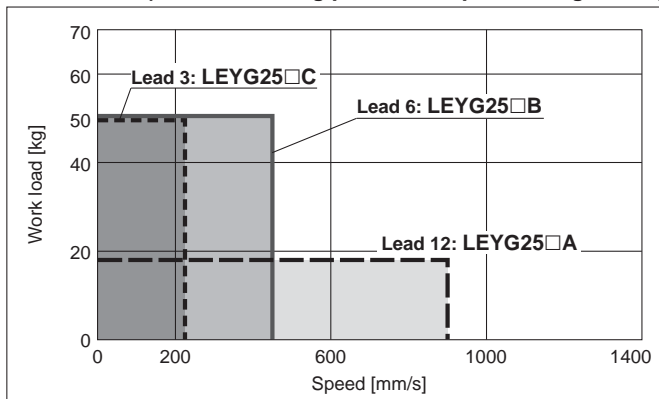

LEYG32□ (Motor mounting position: Top mounting)

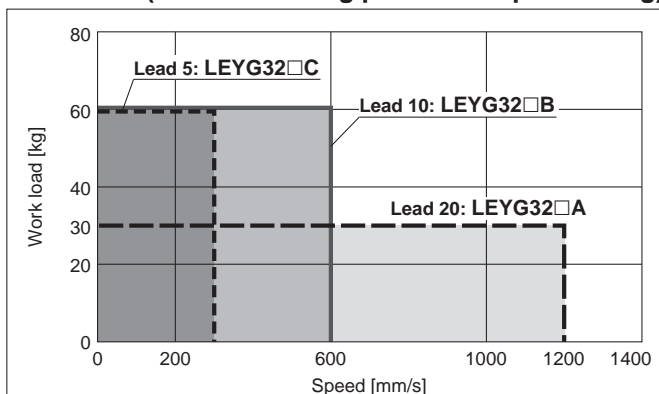

* These graphs show the work load when the external guide is used together. When using the LEYG alone, refer to pages 101 and 102.

LEYG32D (Motor mounting position: In-line)

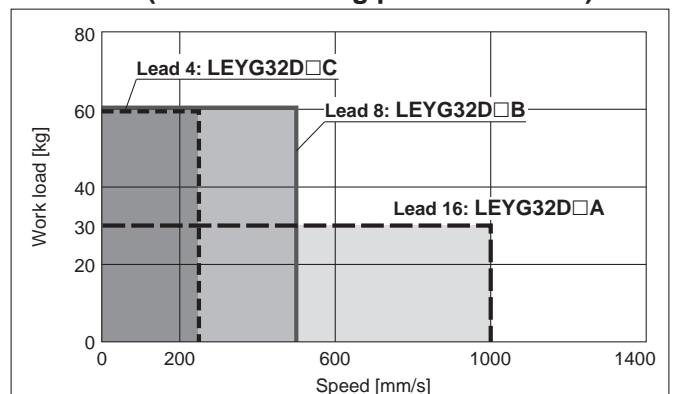

Force Conversion Graph

* These graphs show an example of when the standard motor is mounted. Calculate the force based on used motor and driver.

LEYG25□ (Motor mounting position: Top mounting/In-line)

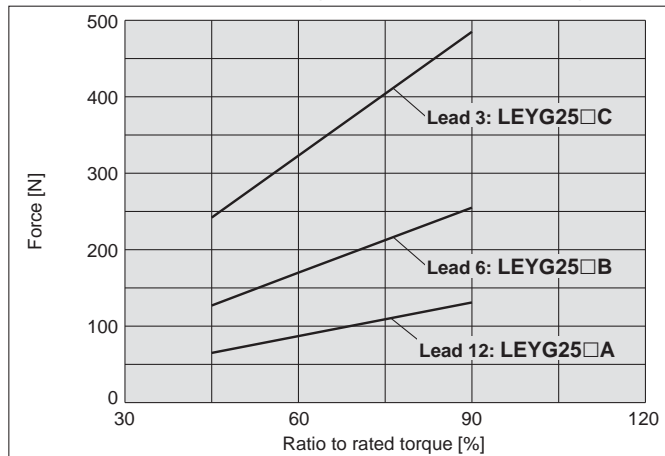

LEYG32□ (Motor mounting position: Top mounting)

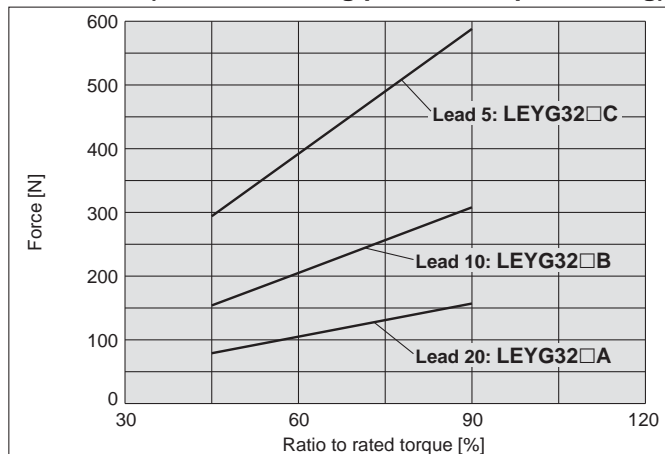

LEYG32D (Motor mounting position: In-line)

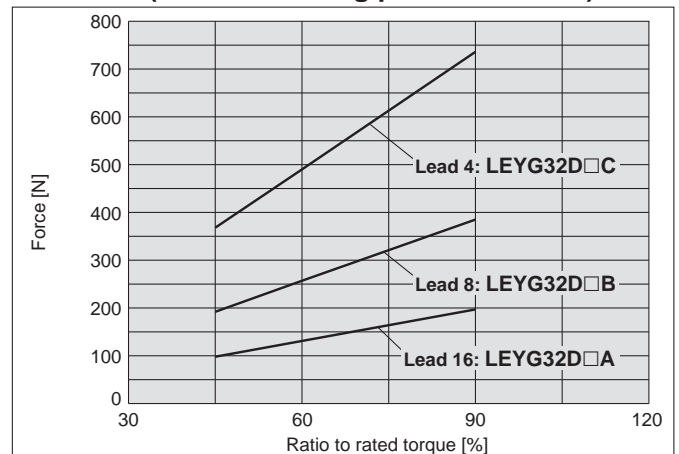

* When using the force control or speed control, set the maximum value to be less than 90 % of the rated torque.

Model Selection

LEFS

LEFB

LEJS

LEY

LEYG

Motor Mounting

Electric Actuator/ Guide Rod Type

Series **LEYG** LEYG25, 32



RoHS

How to Order

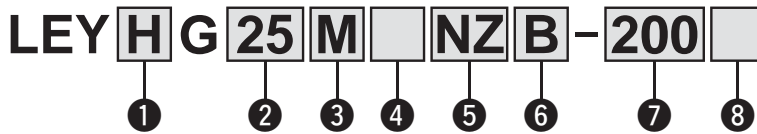

1 Accuracy

—	Basic type
H	High precision type

2 Size

25
32

3 Bearing type

M	Sliding bearing
L	Ball bushing bearing

4 Motor mounting position

—	Top mounting
D	In-line

5 Motor type

Symbol	Type
NZ	Mounting type Z
NY	Mounting type Y
NX	Mounting type X
NW	Mounting type W
NV	Mounting type V
NU	Mounting type U
NT	Mounting type T
NM1	Mounting type M1
NM2	Mounting type M2

* Refer to the "Compatible Motors."

6 Lead [mm]

Symbol	LEYG25	LEYG32*
A	12	16 (20)
B	6	8 (10)
C	3	4 (5)

* The values shown in () are the lead for size 3 2 top mounting type. (Equivalent lead which includes the pulley ratio [1.25:1])

7 Stroke [mm]

30	30
to	to
300	300

* Refer to the applicable stroke table.

8 Guide option

—	Without option
F	With grease retaining function

* Only available for sliding bearing.

Applicable Stroke Table

●: Standard

Model \ Stroke [mm]	30	50	100	150	200	250	300
LEYG25	●	●	●	●	●	●	●
LEYG32	●	●	●	●	●	●	●

* Please consult with SMC for non-standard strokes as they are produced as special orders.

When using an auto switch with the guide rod type LEYG series

- Insert the auto switch from the front side with the rod (plate) extended.
- For the parts hidden behind the guide attachment (Rod end), the auto switch cannot be fixed.
- Please consult with SMC when using an auto switch at the rod end, as it is produced as a special order.

For auto switches, refer to pages 117 to 119.

Compatible Motors

Applicable motor model			Size/Motor type														
Manufacturer	Series	Type	25						32								
			NZ Mounting type Z	NY Mounting type Y	NX Mounting type X	NM1 Mounting type M1	NM2 Mounting type M2	NZ Mounting type Z	NY Mounting type Y	NX Mounting type X	NW Mounting type W	NV Mounting type V	NU Mounting type U	NT Mounting type T	NM1 Mounting type M1	NM2 Mounting type M2	
Mitsubishi Electric Corporation	MELSERVO-JN	HF-KN	●	—	—	—	—	●	—	—	—	—	—	—	—	—	—
	MELSERVO-J3	KF-KP	●	—	—	—	—	●	—	—	—	—	—	—	—	—	—
	MELSERVO-J4	HG-KR	●	—	—	—	—	●	—	—	—	—	—	—	—	—	—
YASKAWA Electric Corporation	Σ-V	SGMJV	●	—	—	—	—	●	—	—	—	—	—	—	—	—	—
SANYO DENKI CO., LTD.	SANMOTION R	R2	●	—	—	—	—	●	—	—	—	—	—	—	—	—	—
OMRON Corporation	Sysmac G5	R88M-K	●	—	—	—	—	—	●	—	—	—	—	—	—	—	—
Panasonic Corporation	MINAS-A4	MSMD	—	●	—	—	—	—	—	●	—	—	—	—	—	—	—
	MINAS-A5	MSMD/MHMD	—	●	—	—	—	—	—	●	—	—	—	—	—	—	—
FANUC CORPORATION	βis	β	●	—	—	—	—	—	●	—	—	●	—	—	—	—	—
NIDEC SANKYO CORPORATION	S-FLAG	MA/MH/MM	●	—	—	—	—	—	●	—	—	—	—	—	—	—	—
KEYENCE CORPORATION	SV	SV-M/SV-B	●	—	—	—	—	—	●	—	—	—	—	—	—	—	—
FUJI ELECTRIC CO., LTD.	ALPHA5	GYS/GYB	●	—	—	—	—	—	●	—	—	—	—	—	—	—	—
	FALDIC-α	GYS	●	—	—	—	—	—	●	—	—	—	—	—	—	—	—
ORIENTAL MOTOR Co., Ltd.	AR/AZ	AR/AZ	—	—	—	—	—	—	●	—	—	—	—	—	—	—	●
FASTECH Co., Ltd.	Ezi-SERVO	EzM	—	—	—	●	—	—	—	—	—	—	—	—	—	—	●
Rockwell Automation, Inc. (Allen-Bradley)	MP-/VP-	MP/VP	—	—	—	—	—	—	—	—	●*	—	—	—	—	—	—
	TL	TLY-A	●	—	—	—	—	—	—	—	—	—	—	—	●	—	—
Beckhoff Automation GmbH	AM	AM30	●	—	—	—	—	—	—	—	—	—	●*	—	—	—	—
	AM	AM31	●	—	—	—	—	—	—	—	—	—	—	●	—	—	—
	AM	AM80/AM81	●	—	—	—	—	—	—	—	●*	—	—	—	—	—	—
Siemens AG	1FK7	1FK7	—	—	●	—	—	—	—	—	●*	—	—	—	—	—	—
	1FK2	1FK2	●	—	—	—	—	—	●	—	—	—	—	●	—	—	—
Delta Electronics, Inc.	ASDA-A2	ECMA	●	—	—	—	—	—	●	—	—	—	—	—	—	—	—

* Motor mounting position: In-line only

Specifications

• The values given below are within the actuator body specification range, with a standard motor mounted and should not be exceeded.

Model		LEYG25 ^M (Top mounting) LEYG25 ^M D (In-line)			LEYG32 ^M (Top mounting)			LEYG32 ^M D (In-line)		
Stroke [mm] ^{Note 1)}		30, 50, 100, 150, 200, 250, 300			30, 50, 100, 150, 200, 250, 300			30, 50, 100, 150, 200, 250, 300		
Work load [kg]	Horizontal ^{Note 2)}	18	50	50	30	60	60	30	60	60
	Vertical	7	15	29	7	17	35	10	22	44
Pushing force [N] ^{Note 3)} (Set value: Rated torque 30 to 90 %)		65 to 131	127 to 255	242 to 485	79 to 157	154 to 308	294 to 588	98 to 197	192 to 385	368 to 736
Max. speed [mm/s]		900	450	225	1200	600	300	1000	500	250
Pushing speed [mm/s] ^{Note 4)}		35 or less			30 or less					
Max. acceleration/deceleration [mm/s ²]					5000					
Positioning repeatability [mm]	Basic type				±0.02					
	High precision type				±0.01					
Lost motion ^{Note 5)} [mm]	Basic type				0.1 or less					
	High precision type				0.05 or less					
Ball screw specifications	Thread size [mm]	Ø 10			Ø 12					
	Lead [mm] (including pulley ratio)	12	6	3	16 (20)	8 (10)	4 (5)	16	8	4
	Shaft length [mm]	Stroke + 93.5			Stroke + 104.5					
Impact/Vibration resistance [m/s ²] ^{Note 6)}					50/20					
Actuation type		Ball screw + Belt (LEYG□) Ball screw (LEYG□D)			Ball screw + Belt [Pulley ratio 1.25:1]			Ball screw		
Guide type					Sliding bearing (LEYG□M), Ball bushing bearing (LEYG□L)					
Operating temperature range [°C]					5 to 40					
Operating humidity range [%RH]					90 or less (No condensation)					
Actuation unit weight [kg] (*[ST]: Stroke)	Sliding bearing LEYG□M	0.29 + (2.20 × 10 ⁻³) × [ST]: 185 st or less 0.34 + (1.92 × 10 ⁻³) × [ST]: Over 185 st			0.48 + (2.91 × 10 ⁻³) × [ST]: 180 st or less 0.55 + (2.62 × 10 ⁻³) × [ST]: Over 180 st					
	Ball bushing bearing LEYG□L	0.33 + (1.69 × 10 ⁻³) × [ST]: 110 st or less 0.36 + (1.80 × 10 ⁻³) × [ST]: Over 110 st			0.50 + (2.40 × 10 ⁻³) × [ST]: 110 st or less 0.55 + (2.51 × 10 ⁻³) × [ST]: Over 110 st					
Other inertia [kg-cm ²]		0.012 (LEYG25) 0.015 (LEYG25D)			0.035 (LEYG32)			0.061 (LEYG32D)		
Coefficient of friction					0.05					
Mechanical efficiency					0.8					
Reference motor spec.	Motor shape	□40			□60					
	Motor type				AC servo motor					
	Rated output capacity [W]	100			200					
	Rated torque [N-m]	0.32			0.64					
	Rated rotation [rpm]				3000					

Note 1) Please consult with SMC for non-standard strokes as they are produced as special orders.

Note 2) The maximum value of the horizontal work load. An external guide is necessary to support the load. The actual work load will vary according to the condition of the external guide. Confirm using actual device.

Note 3) The force setting range for the pushing operation (Speed control mode, Torque control mode).

The pushing force will vary according to the set value. Set it with reference to the "Force Conversion Graph" on page 104.

Note 4) The allowable collision speed for the pushing operation.

Note 5) A reference value for correcting an error in reciprocal operation.

Note 6) Impact resistance: No malfunction occurred when the actuator was tested with a drop tester in both an axial direction and a perpendicular direction to the lead screw. (Test was performed with the actuator in the initial state.)

Vibration resistance: No malfunction occurred in a test ranging between 45 to 2000 Hz. Test was performed in both an axial direction and a perpendicular direction to the lead screw. (Test was performed with the actuator in the initial state.)

Note 7) The values are a guide only and should be used to select a motor capacity.

Weight

Product Weight

Model	[kg]													
	LEYG25 ^M (Motor mounting position: Top mounting)							LEYG32 ^M (Motor mounting position: Top mounting)						
Stroke [mm]	30	50	100	150	200	250	300	30	50	100	150	200	250	300
Sliding bearing LEYG□M	1.3	1.5	1.8	2.2	2.6	2.9	3.2	2.2	2.5	3.1	3.8	4.4	4.8	5.3
Ball bushing bearing LEYG□L	1.3	1.5	1.8	2.2	2.5	2.8	3.0	2.2	2.5	2.9	3.6	4.1	4.6	5.0

Model	[kg]													
	LEYG25 ^M D (Motor mounting position: In-line)							LEYG32 ^M D (Motor mounting position: In-line)						
Stroke [mm]	30	50	100	150	200	250	300	30	50	100	150	200	250	300
Sliding bearing LEYG□M	1.3	1.5	1.8	2.3	2.6	2.9	3.2	2.3	2.5	3.1	3.8	4.4	4.9	5.3
Ball bushing bearing LEYG□L	1.3	1.6	1.8	2.2	2.5	2.8	3.0	2.3	2.5	2.9	3.7	4.1	4.6	5.0

Model Selection
LEFS
LEFB
LEJS
LEY
LEYG
Motor Mounting

Series LEYG

Motorless Type

Refer to the "Motor Mounting" on page 109 for details of motor mounting and parts included.

Dimensions: Motor Top Mounting

LEYG25, 32

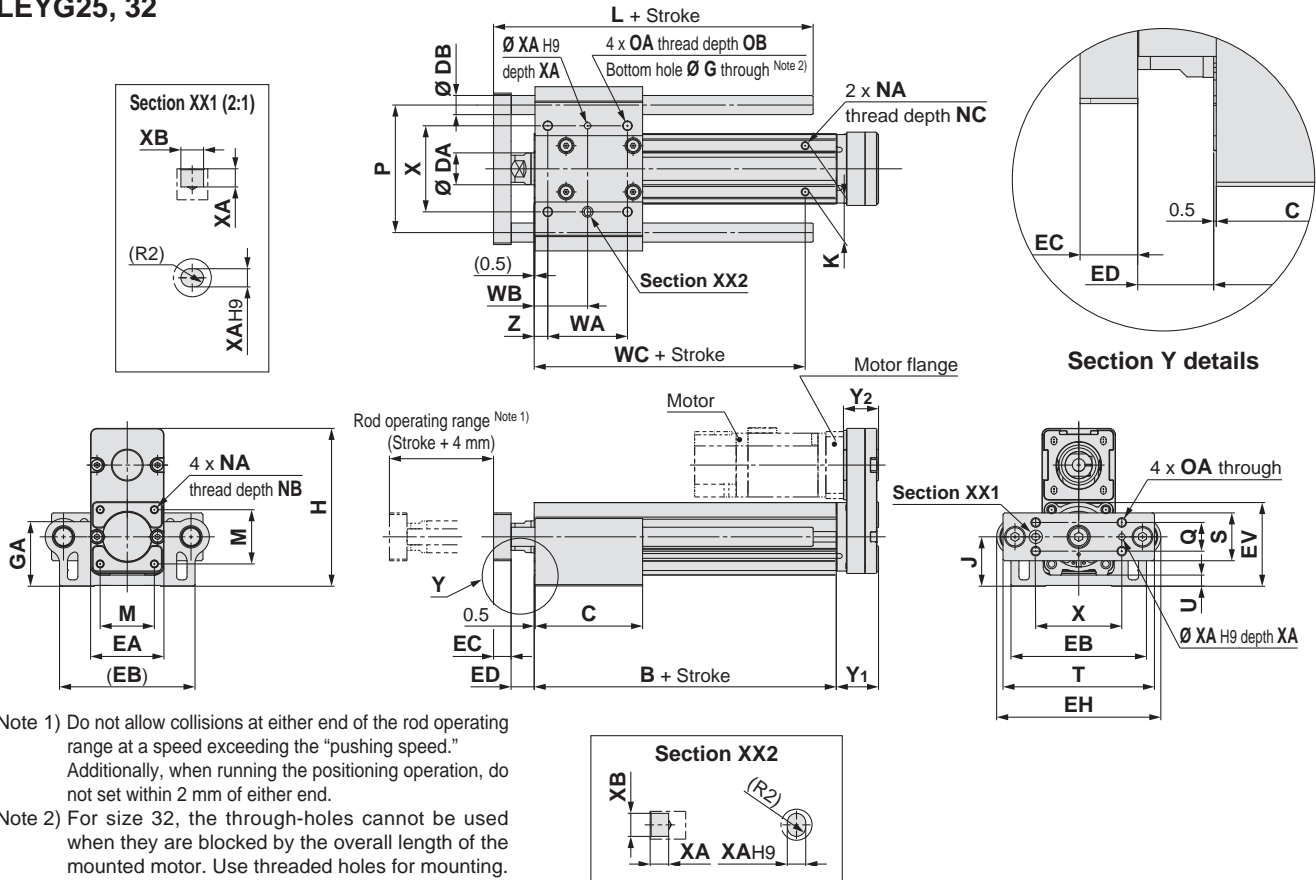

Note 1) Do not allow collisions at either end of the rod operating range at a speed exceeding the "pushing speed." Additionally, when running the positioning operation, do not set within 2 mm of either end.

Note 2) For size 32, the through-holes cannot be used when they are blocked by the overall length of the mounted motor. Use threaded holes for mounting.

LEYG□L (Ball bushing bearing) [mm]			
Size	Stroke range [mm]	L	DB
25	Up to 110	91	10
	115 to 190	115	
	195 to 300	133	
32	Up to 110	97.5	13
	115 to 190	116.5	
	195 to 300	134	

LEYG□M (Sliding bearing) [mm]			
Size	Stroke range [mm]	L	DB
25	Up to 55	67.5	12
	60 to 185	100.5	
	190 to 300	138	
32	Up to 55	74	16
	60 to 185	107	
	190 to 300	144	

* Refer to page 109 for the dimensions of the motor flange.

LEYG□M, LEYG□L Common

Size	Stroke range [mm]	B	C	DA	EA	EB	EH	EV	EC	ED	G	GA	H	J	K	M	NA	NB
25	Up to 35	89.5	50	20	46	85	103	52.3	11	12.5	5.4	40.3	98.8	30.8	29	34	M5 x 0.8	8
	40 to 100		67.5															
	105 to 120		84.5															
	125 to 200		102															
32	Up to 35	96	55	25	60	101	123	63.8	12	16.5	5.4	50.3	125.3	38.3	30	40	M6 x 1.0	10
	40 to 100		68															
	105 to 120		85															
	125 to 200		102															
Size	Stroke range [mm]	NC	OA	OB	P	Q	S	T	U	WA	WB	WC	X	XA	XB	Y1	Y2	Z
25	Up to 35	6.5	M6 x 1.0	12	80	18	30	95	6.8	35	26	70	54	4	5	26.5	22	8.5
	40 to 100									50	33.5							
	105 to 120									70	43.5							
	125 to 200									85	51							
32	Up to 35	8.5	M6 x 1.0	12	95	28	40	117	7.3	40	28.5	75	64	5	6	34	27	8.5
	40 to 100									50	33.5							
	105 to 120									70	43.5							
	125 to 200									85	51							

* The ED measurement is when the unit is at the retracted stroke end position.

Refer to the "Motor Mounting" on page 110 for details of motor mounting and parts included.

Dimensions: In-line Motor

LEYG25, 32

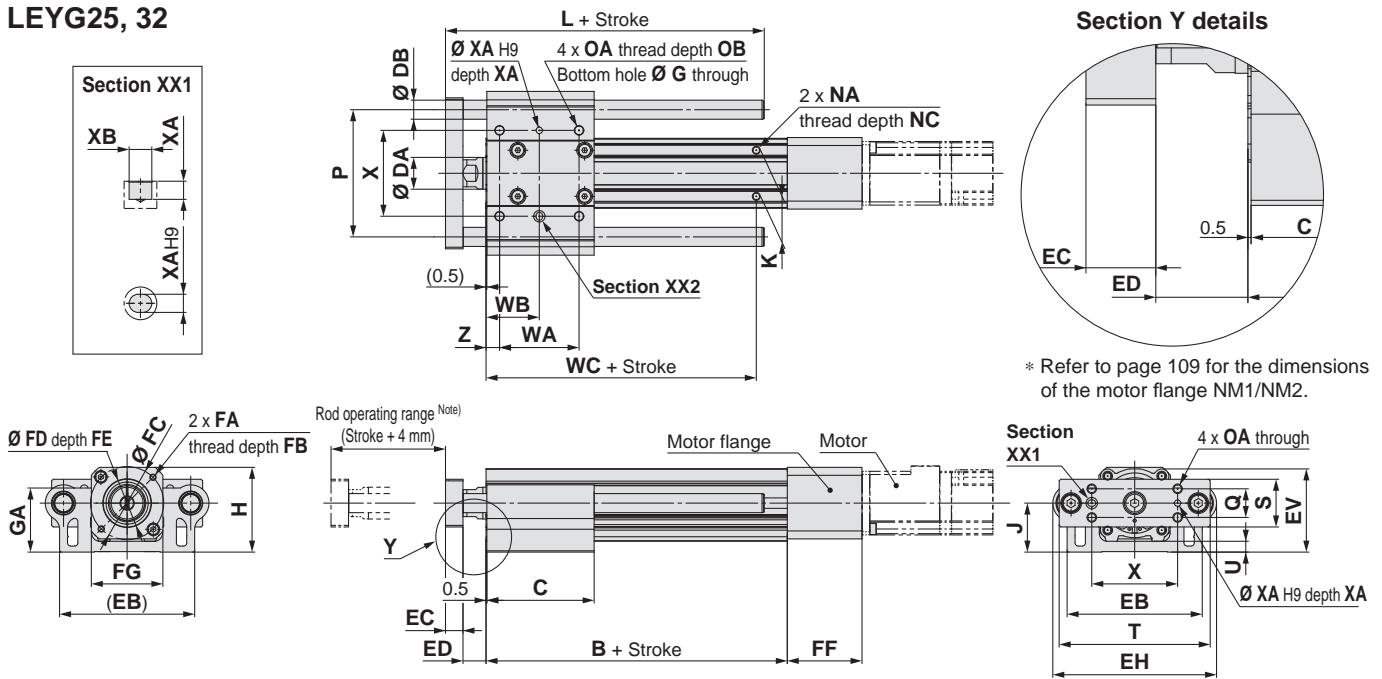

LEYG□L (Ball bushing bearing) [mm]

Size	Stroke range [mm]	L	DB
25	Up to 114	91	10
	115 to 190	115	
	191 to 300	133	
32	Up to 114	97.5	13
	115 to 190	116.5	
	191 to 300	134	

LEYG□M (Sliding bearing) [mm]

Size	Stroke range [mm]	L	DB
25	Up to 55	67.5	12
	60 to 185	100.5	
	190 to 300	138	
32	Up to 55	74	16
	60 to 185	107	
	190 to 300	144	

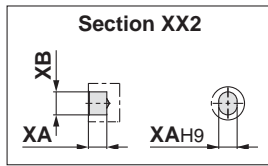

Note) Do not allow collisions at either end of the rod operating range at a speed exceeding the "pushing speed." Additionally, when running the positioning operation, do not set within 2 mm of either end.

Dimensions [mm]

Size	Motor type	FA	FB	FC	FD	FE	FF	FG	FH
25	NZ, NX	M4 x 0.7	7.5	46	30	3.7	47	45	—
	NY	M3 x 0.5	6	45	30	4.2	47	45	—
	NM1	ø3.4	17	31	22	2.5	36	45	19
	NM2	ø3.4	28	31	30	3.5	56	45	30
32	NZ, NW, NU, NT	M5 x 0.8	8.5	70	50	3.3	60	60	—
	NY	M4 x 0.7	8	70	50	3.3	60	60	—
	NX	M5 x 0.8	8.5	63	40	3.5	63	60	—
	NV	M4 x 0.7	8	63	40	3.5	63	60	—
	NM1	M4 x 0.7	8	47.14	38.1	2	34	60	51.5
	NM2	M4 x 0.7	8	50	36	3.3	60	60	—

LEYG□M, LEYG□L Common

[mm]

Size	Stroke range [mm]	B	C	DA	EB	EH	EV	EC	ED	G	GA	H	J	K	NA	
25	Up to 35	89.5	50	20	85	103	52.3	11	12.5	5.4	40.3	53.3	30.8	29	M5 x 0.8	
	40 to 100		67.5													
	105 to 120		84.5													
	125 to 200		102													
	205 to 300		114.5													
32	Up to 35	96	55	25	101	123	63.8	12	16.5	5.4	50.3	68.3	38.3	30	M6 x 1.0	
	40 to 100		68													
	105 to 120		85													
	125 to 200		102													
	205 to 300		126													
Size	Stroke range [mm]	NC	OA	OB	P	Q	S	T	U	WA	WB	WC	X	XA	XB	Z
25	Up to 35	6.5	M6 x 1.0	12	80	18	30	95	6.8	35	26	70	54	4	5	8.5
	40 to 100									50	33.5					
	105 to 120									70	43.5	95				
	125 to 200									85	51					
	205 to 300									105	51					
32	Up to 35	8.5	M6 x 1.0	12	95	28	40	117	7.3	40	28.5	75	64	5	6	8.5
	40 to 100									50	33.5					
	105 to 120									70	43.5	105				
	125 to 200									85	51					
	205 to 300									105	51					

* The ED measurement is when the unit is at the retracted stroke end position.

Series LEY/LEYG

Motorless Type

- The motor and motor mounting screws should be provided by user.
- Motor shaft style should be cylindrical for the NZ, NY, NW, NM2 motor types, and D-cut style for the NM1 motor type.
- When mounting a pulley, remove any oil content, dust, or dirt from the shaft and pulley inside diameter.
- Take measures to prevent the motor mounting screws and socket head set screws becoming loose.

Motor Mounting: Top/Parallel

LEY25, LEYG25
32, LEYG32

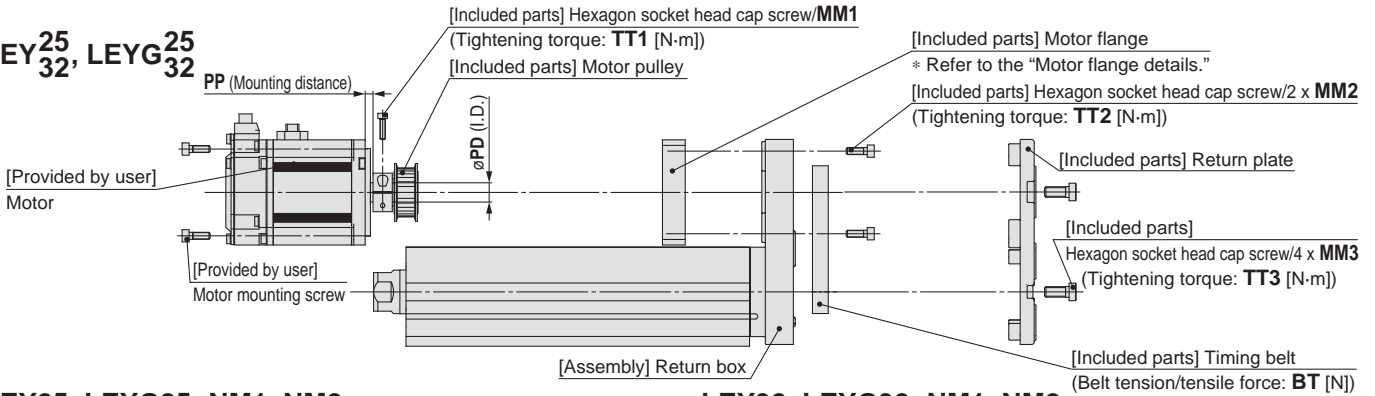

LEY25, LEYG25: NM1, NM2

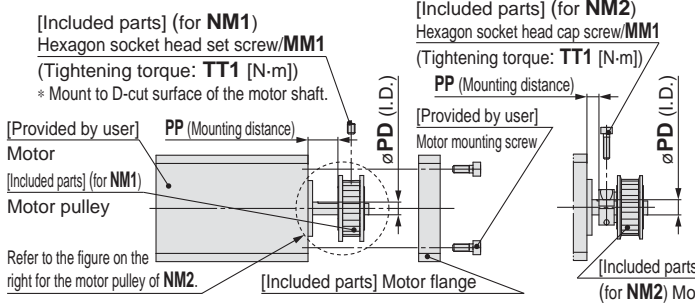

LEY32, LEYG32: NM1, NM2

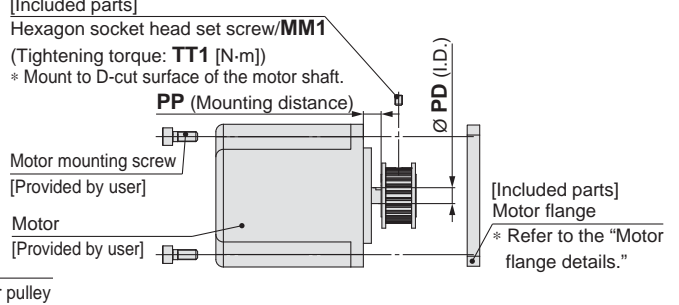

Motor flange details

LEY25: NZ, NY, NX

LEY32: NZ, NY, NW, NU, NT

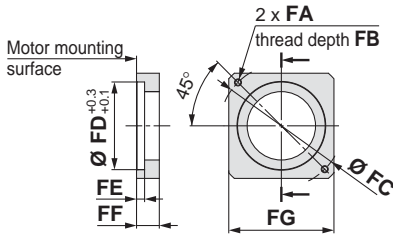

LEY25: NM1, NM2

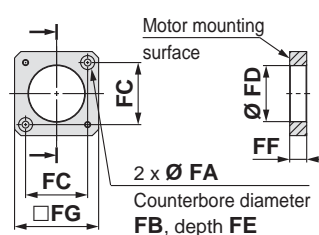

LEY32: NM1, NM2

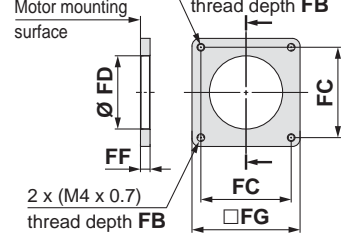

Dimensions

Size	Motor type	MM1	TT1	MM2	TT2	MM3	TT3	PD	PP	BT	FA	FB	FC	FD	FE	FF	FG
25	NZ	M2.5 x 10	1.0	M3 x 8	0.63	M4 x 10	1.5	8	7.5	19	M4 x 0.7	7.5	46	30	3.7	11	42
	NY	M2.5 x 10	1.0	M3 x 8	0.63	M4 x 10	1.5	8	7.5	19	M3 x 0.5	5.5	45	30	5	11	38
	NX	M2.5 x 10	1.0	M3 x 8	0.63	M4 x 10	1.5	8	4.5	19	M4 x 0.7	7.5	46	30	3.7	11	42
	NM1	M3 x 5	0.63	M3 x 8	0.63	M4 x 10	1.5	5	11.8	19	$\varnothing 3.4$	7.0	31	28	3.5	8.5	42
	NM2	M2.5 x 10	1.0	M3 x 8	0.63	M4 x 10	1.5	6	48	19	$\varnothing 3.4$	7.0	31	28	3.5	8.5	42
32	NZ	M3 x 12	1.5	M4 x 12	1.5	M6 x 14	5.2	14	4.5	30	M5 x 0.8	8.5	70	50	4.6	13	60
	NY	M3 x 12	1.5	M4 x 12	1.5	M6 x 14	5.2	11	4.5	30	M4 x 0.7	7	70	50	4.6	13	60
	NW	M4 x 12	3.6	M4 x 12	1.5	M6 x 14	5.2	9	4.5	30	M5 x 0.8	8.5	70	50	4.6	13	60
	NU	M3 x 12	1.5	M4 x 12	1.5	M6 x 14	5.2	11	4.5	30	M5 x 0.8	8.5	70	50	4.6	13	60
	NT	M3 x 12	1.5	M4 x 12	1.5	M6 x 14	5.2	12	8.5	30	M5 x 0.8	8.5	70	50	4.6	17	60
	NM1	M3 x 5	0.63	M4 x 12	1.5	M6 x 14	5.2	6.35	7.1	30	M4 x 0.7	(5)	47.1	38.2	—	5	56.4
	NM2	M3 x 12	1.5	M4 x 12	1.5	M6 x 14	5.2	10	12	30	M4 x 0.7	8	50	38.2	—	11.5	60

Motor Mounting Diagram

Mounting procedure

- 1) Fix the motor (provided by user) and the "motor pulley" with the "MM1 hexagon socket head cap screw or set screw."
- 2) Fix the motor and the "motor flange" with the motor mounting screws (provided by user).
- 3) Put the "timing belt" on the "motor pulley" and "body side pulley", and then fix it temporarily with the "MM2 hexagon socket head cap screws."
- 4) Apply the belt tension and tighten the timing belt with the "MM2 hexagon socket head cap screws." (The reference level is the elimination of the belt deflection.)
- 5) Fix the "return plate" with the "MM3 hexagon socket head cap screws."

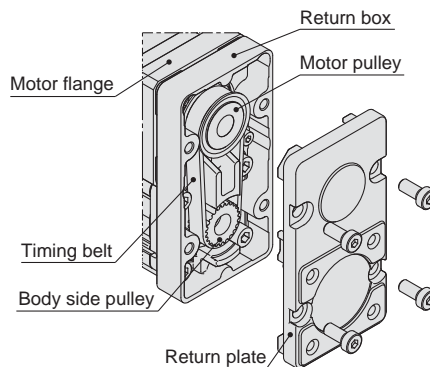

Parts List

Size: 25, 32

Description	Quantity	
	NZ, NY, NW, NT, NM2	NM1
Motor flange	1	1
Motor pulley	1	1
Return plate	1	1
Timing belt	1	1
Hexagon socket head cap screw (for return plate mounting)	4	4
Hexagon socket head cap screw (for motor flange mounting)	2	2
Hexagon socket head cap screw (for pulley fixing)	1	—
Hexagon socket head set screw (for pulley fixing)	—	1

Electric Actuators Rod Type/Guide Rod Type **Series LEY/LEYG**

Motorless Type

- The motor and motor mounting screws should be provided by user.
- Motor shaft style should be cylindrical for the NZ, NY, NX, NW, NM 2 motor types, and D-cut style for the NM1 motor type.
- When mounting a hub, remove any oil, dust, or dirt from the shaft and hub inside diameter.
- Take measures to prevent the motor mounting screws and socket head set screws becoming loose.

Motor Mounting: In-line

LEY25D, LEYG25□D

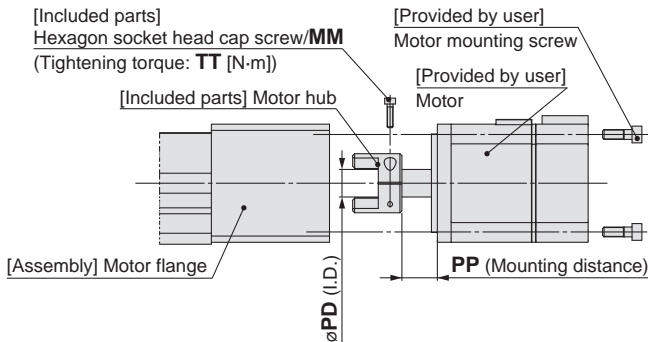

Mounting procedure

- 1) Fix the motor (provided by user) and the "motor hub" with the "MM hexagon socket head cap screw."
- 2) Check the "motor hub" position, and then insert it. (Refer to the mounting diagram.)
- 3) Fix the motor and the "motor flange" with the motor mounting screws (provided by user).

LEY25D, LEYG25□D: NM1

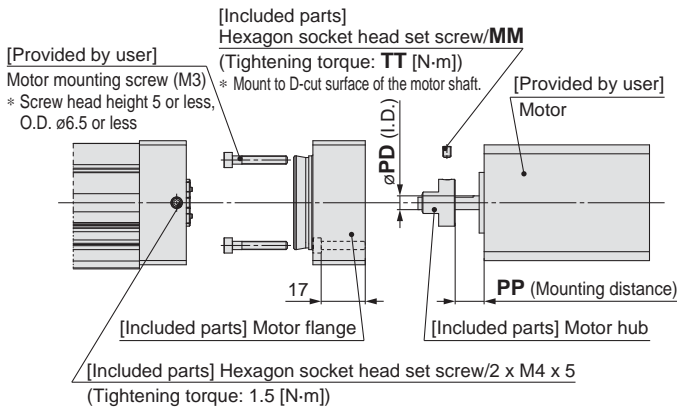

Mounting procedure

- 1) Fix the motor (provided by user) and the "motor hub" with the M3 x 4 hexagon socket head set screw.
- 2) Fix the motor and the "motor flange" with the motor mounting screws (provided by user).
- 3) Check the "motor hub position", and then insert it. (Refer to the mounting diagram.)
- 4) Fix the "motor flange" with the "M4 x 5 hexagon socket head set screws."

LEY32D, LEYG32□D: NM1

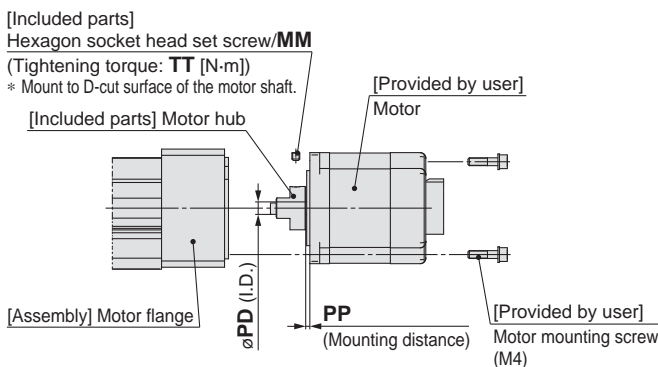

Mounting procedure

- 1) Fix the motor (provided by user) and the motor hub with the "MM hexagon socket head set screw."
- 2) Check the "motor hub" position, and then insert it. (Refer to the mounting diagram.)
- 3) Fix the motor and the "motor block" with the motor mounting screws (provided by user).

LEY25D, LEYG25□D: NM2

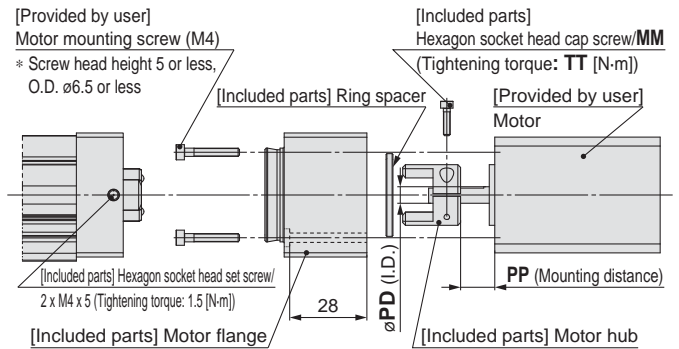

Mounting procedure

- 1) Insert the "ring spacer" into the motor (provided by user).
- 2) Fix the motor (provided by user) and the "motor hub" with the M2.5 x 10 hexagon socket head cap screw.
- 3) Fix the motor and the "motor flange" with the motor mounting screws (provided by user).
- 4) Check the "motor hub" position, and then insert it. (Refer to the mounting diagram.)
- 5) Fix the "motor flange" with the "M4 x 5 hexagon socket head set screws."

Motor Mounting Diagram

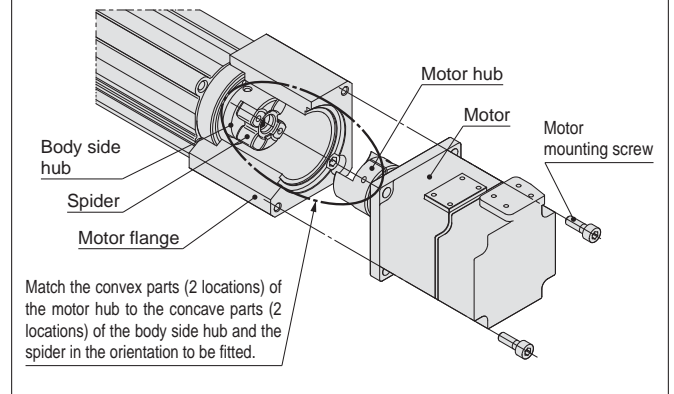

Dimensions

		[mm]				
Size	Motor type	MM	TT	PD	PP	
25	NZ	M2.5 x 10	1.0	8	12.5	
	NY	M2.5 x 10	1.0	8	12.5	
	NX	M2.5 x 10	1.0	8	7	
	NM1	M3 x 5	0.63	5	10.5	
	NM2	M2.5 x 10	1.0	6	12.4	
32	NZ	M3 x 12	1.5	14	18	
	NY	M4 x 12	3.6	11	18	
	NX	M4 x 12	3.6	9	5	
	NW	M4 x 12	3.6	9	12	
	NV	M4 x 12	3.6	9	5	
	NU	M4 x 12	3.6	11	12	
	NT	M3 x 12	1.5	12	18	
	NM1	M4 x 5	1.5	6.35	2.1	
NM2	M4 x 12	3.6	10	3		

Included Parts List

Size: 25

Description	Quantity		
	Motor type		
	NZ, NY, NX	NM1	NM2
Motor hub	1	1	1
Hexagon socket head cap screw (for hub fixing)	1	—	1
Motor flange	—	1	1
Hexagon socket head set screw (for hub fixing)	—	1	—
Hexagon socket head set screw (for motor flange fixing)	—	2	2
Ring spacer	—	—	1

Size: 32

Description	Quantity	
	Motor type	
	NZ, NY, NX, NW, NV, NU, NT, NM2	NM1
Motor hub	1	1
Hexagon socket head cap screw (for hub fixing)	1	—
Hexagon socket head set screw (for hub fixing)	—	1

Series LEY/LEYG

Motorless Type

Motor Mounting: Top/Parallel

LEY63

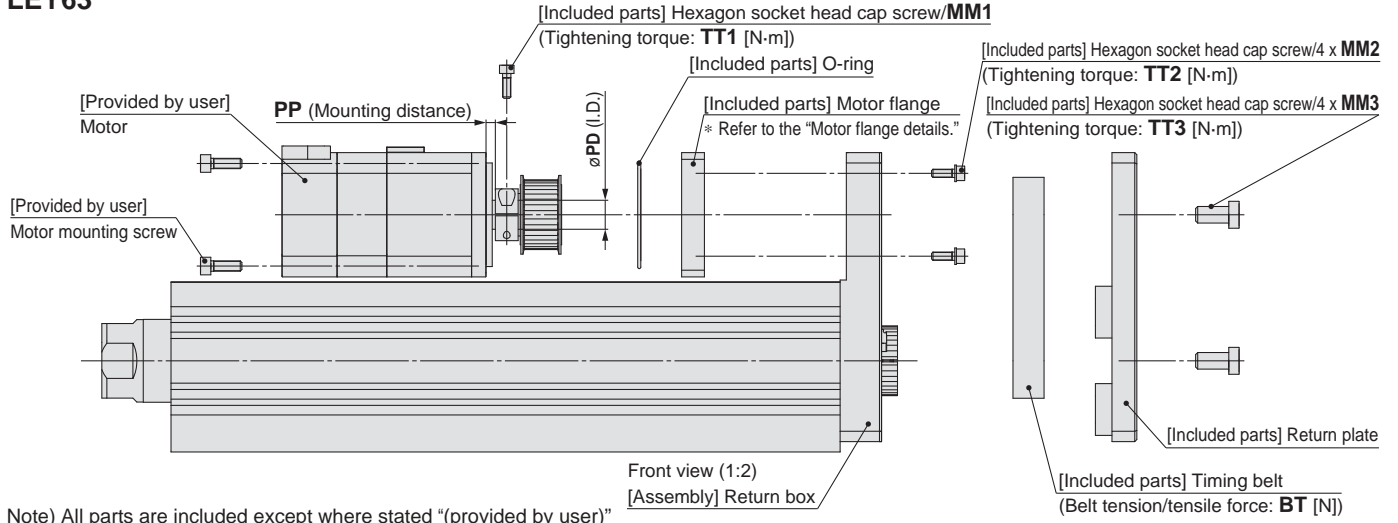

Motor flange details

LEY63: NZ, NY, NW, NT

⚠ Be careful about the motor flange mounting direction.

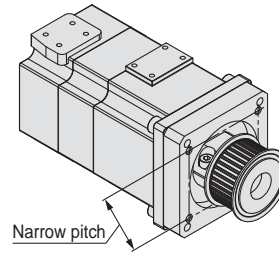
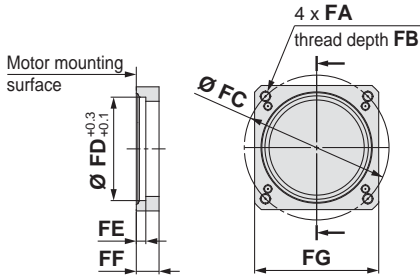

Dimensions

Motor type	MM1	TT1	MM2	TT2	MM3	TT3	PD	PP	BT	FA	FB	FC	FD	FE	FF	FG
NZ	M4 x 12	3.6	M4 x 12	2.7	M8 x 16	12.5	14	4.5	98	M5 x 0.8	8.5	70	50	4.6	11	60
NY	M4 x 12	3.6	M4 x 12	2.7	M8 x 16	12.5	14	4.5	98	M4 x 0.7	8	70	50	4.6	11	60
NW	M4 x 12	3.6	M4 x 12	2.7	M8 x 16	12.5	9	9	98	M5 x 0.8	8.5	70	50	4.6	11	60
NT	M4 x 12	3.6	M4 x 12	2.7	M8 x 16	12.5	12	8	98	M5 x 0.8	8.5	70	50	4.6	14.5	60

Motor Mounting Diagram

Mounting procedure

- 1) Fix the motor (provided by user) and the "motor pulley" with the "MM1 hexagon socket head cap screw."
- 2) Fix the motor and the "motor flange" with the motor mounting screws (provided by user).
- 3) Put the "timing belt" on the "motor pulley" and "body side pulley", and then fix it temporarily with the "MM2 hexagon socket head cap screws."
- 4) Apply the belt tension and tighten the timing belt with the "MM2 hexagon socket head cap screws." (The reference level is the elimination of the belt deflection.)
- 5) Fix the "return plate" with the "MM3 hexagon socket head cap screws."

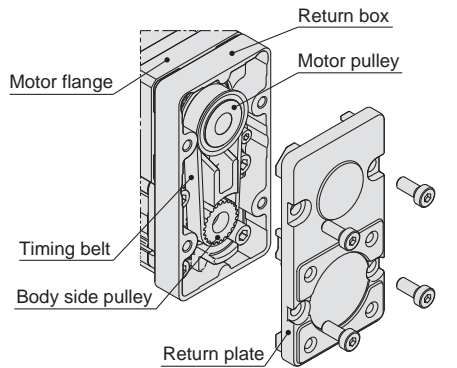

Parts List

Size: 63

Description	Quantity
	Motor type NZ, NY, NW, NT
Motor flange	1
Motor pulley	1
Return plate	1
Timing belt	1
Hexagon socket head cap screw (for return plate mounting)	4
Hexagon socket head cap screw (for motor flange mounting)	4
Hexagon socket head cap screw (for pulley fixing)	1
O-ring	1

- The motor and motor mounting screws should be provided by user.
- The motor drive shaft shape should be of the plain round type, without a keyway.
- When mounting a hub, remove any oil, dust, or dirt from the shaft and hub inside diameter.
- Take measures to prevent the motor mounting screws becoming loose.

Motor Mounting: In-line

LEY63D

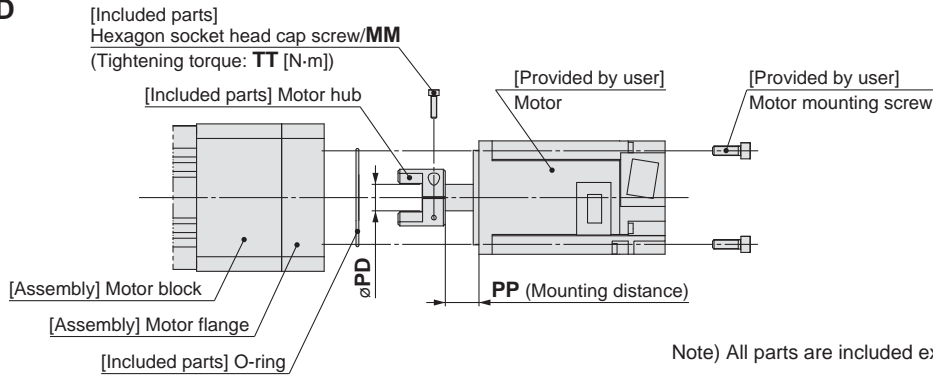

Motor Mounting Diagram

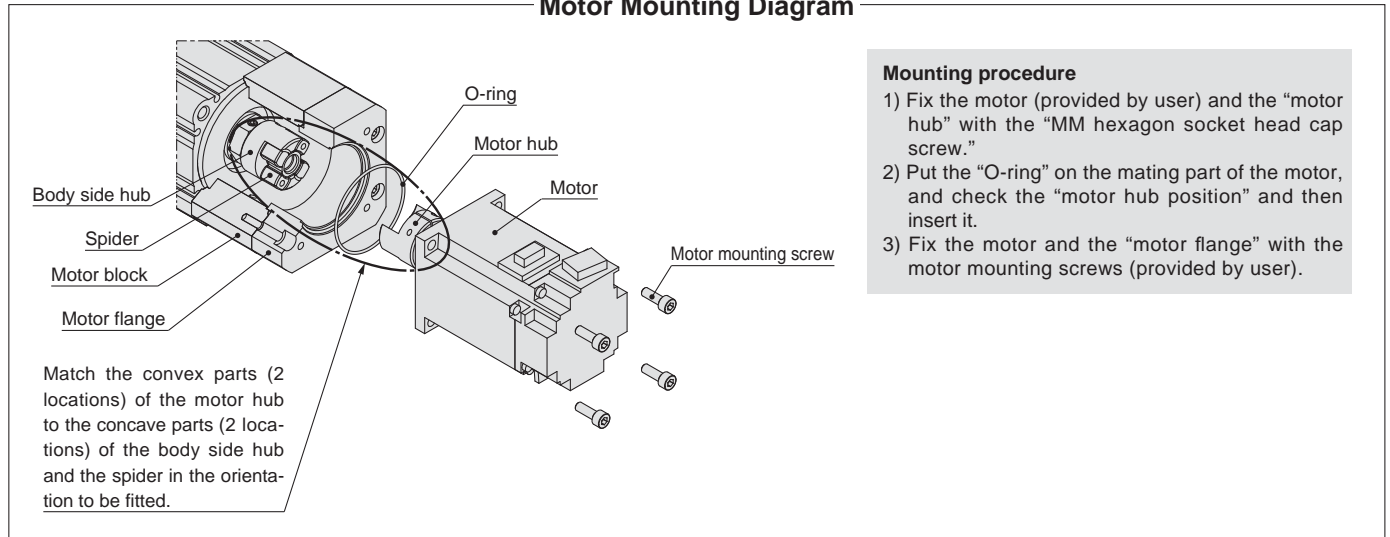

Dimensions

Size	Motor type	MM	TT	PD	PP
63	NZ	M3 x 12	1.5	14	17.7
	NY				
	NX	M4 x 12	3.6	9	6.7
	NW				11.7
	NV	M4 x 12	3.6	9	6.7
	NU	M4 x 12	3.6	11	11.7
NT	M3 x 12	1.5	12	17.7	

Parts List

Size: 63

Description	Quantity
	Motor type
Motor hub	1
Hexagon socket head cap screw (for hub fixing)	1
O-ring	1

Series LEY Motor Mounting Parts

Motor Flange Option

Using this option the motor can be replaced with the motor types shown below. (Except NM1)
Use the following part numbers to select a compatible motor flange option.

How to Order

LEY-MF **25** - **NZ**

①
②
③

① Size

25	For LEY25/LEYG25
32	For LEY32/LEYG32
63	For LEY63

② Motor mounting position

P	Top/Parallel
PL*	Top/Parallel (Lead L)
D	In-line

* Size 63 only

③ Motor type

Symbol	Type	Symbol	Type
NZ	Mounting type Z	NV	Mounting type V
NY	Mounting type Y	NU	Mounting type U
NX	Mounting type X	NT	Mounting type T
NW	Mounting type W	NM2	Mounting type M2

* Refer to the "Compatible Motors."

Compatible Motors

Applicable motor model			Size/Motor type												
Manufacturer	Series	Type	25				32/63								
			NZ Mounting type Z	NY Mounting type Y	NX Mounting type X	NM2 Mounting type M2	NZ Mounting type Z	NY Mounting type Y	NX Mounting type X	NW Mounting type W	NV Mounting type V	NU Mounting type U	NT Mounting type T	NM2 Mounting type M2	
Mitsubishi Electric Corporation	MELSERVO-JN	HF-KN	●	—	—	—	●	—	—	—	—	—	—	—	—
	MELSERVO-J3	HF-KP	●	—	—	—	●	—	—	—	—	—	—	—	—
	MELSERVO-J4	HG-KR	●	—	—	—	●	—	—	—	—	—	—	—	—
YASKAWA Electric Corporation	Σ-V	SGMJV	●	—	—	—	●	—	—	—	—	—	—	—	—
SANYO DENKI CO., LTD.	SANMOTION R	R2	●	—	—	—	●	—	—	—	—	—	—	—	—
OMRON Corporation	Sysmac G5	R88M-K	●	—	—	—	—	●	—	—	—	—	—	—	—
Panasonic Corporation	MINAS-A4	MSMD	—	●	—	—	—	●	—	—	—	—	—	—	—
	MINAS-A5	MSMD/MHMD	—	●	—	—	—	●	—	—	—	—	—	—	—
FANUC CORPORATION	βis	β	●	—	—	—	● (β1 only)	—	—	—	●	—	—	—	—
NIDEC SANKYO CORPORATION	S-FLAG	MA/MH/MM	●	—	—	—	●	—	—	—	—	—	—	—	—
KEYENCE CORPORATION	SV	SV-M/SV-B	●	—	—	—	●	—	—	—	—	—	—	—	—
FUJI ELECTRIC CO., LTD.	ALPHA5	GYS/GYB	●	—	—	—	●	—	—	—	—	—	—	—	—
	FALDIC-α	GYS	●	—	—	—	●	—	—	—	—	—	—	—	—
ORIENTAL MOTOR Co., Ltd.	AR/AZ	AR/AZ	—	—	—	●	—	—	—	—	—	—	—	—	●*3
Rockwell Automation, Inc. (Allen-Bradley)	MP-/VP-	MP/VP	—	—	—	—	—	—	—	●*1	—	—	—	—	—
	TL	TLY-A	●	—	—	—	—	—	—	—	—	—	—	●	—
Beckhoff Automation GmbH	AM	AM30	●	—	—	—	—	—	—	—	—	●*1	—	—	—
	AM	AM31	●	—	—	—	—	—	—	—	—	—	—	●*2	—
	AM	AM80/AM81	●	—	—	—	—	—	—	—	●*1	—	—	—	—
Siemens AG	1FK7	1FK7	—	—	●	—	—	—	—	●*1	—	—	—	—	—
	1FK2	1FK2	●	—	—	—	—	●	—	—	—	—	—	●	—
Delta Electronics, Inc.	ASDA-A2	ECMA	●	—	—	—	—	●	—	—	—	—	—	—	—

Note) When the LEY□²⁵□□NM1□-□ or LEY□G²⁵□□□□NM1□-□ is purchased, it is not possible to change to other motor types.

*1 Motor mounting position: In-line only
*2 Only in-line type is available for size 63.
*3 Except size 63

Dimensions: Motor Flange Option

Motor mounting position: Top/Parallel

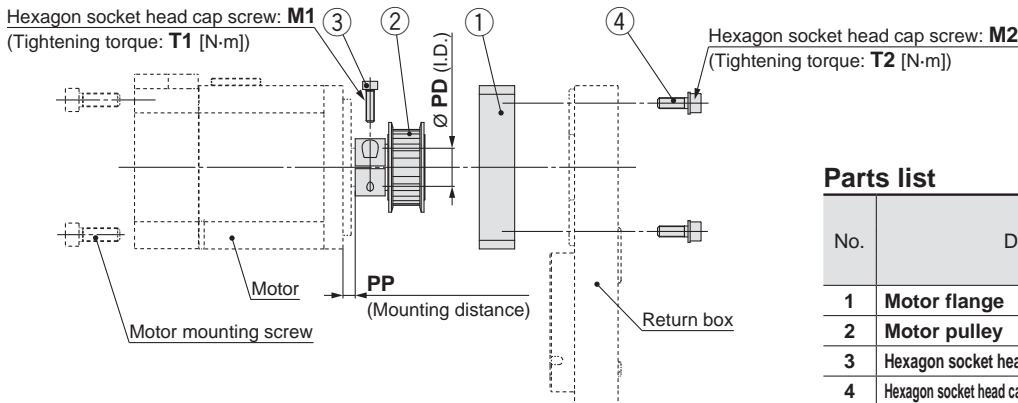

Parts list

No.	Description	Quantity	
		25, 32	63
1	Motor flange	1	1
2	Motor pulley	1	1
3	Hexagon socket head cap screw (for pulley fixing)	1	1
4	Hexagon socket head cap screw (for motor flange mounting)	2	4

Motor flange details

Size: 25, 32

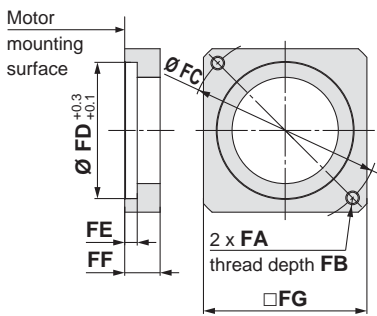

Size 25: NM2

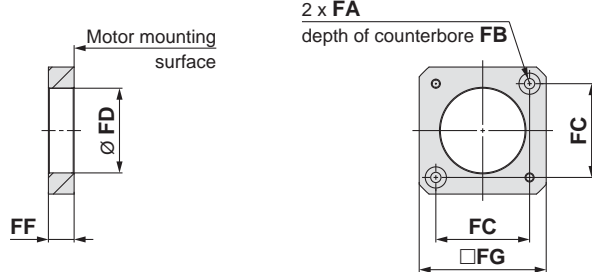

Size: 63

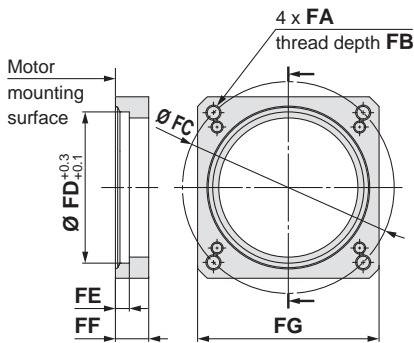

Size 32: NM2

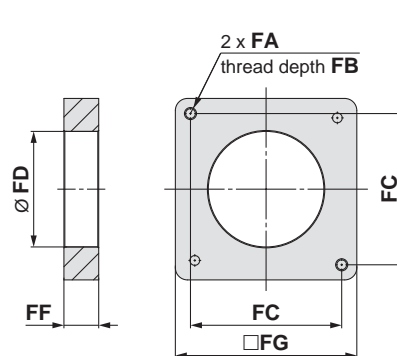

Dimensions

Size	Motor type	FA	FB	FC	FD	FE	FF	FG	M1	T1	M2	T2	PD	PP
25	NZ	M4 x 0.7	7.5	46	30	3.7	11	42	M2.5 x 10	1.0	M3 x 8	0.63	8	7.5
	NY	M3 x 0.5	5.5	45	30	5	11	42	M2.5 x 10	1.0	M3 x 8	0.63	8	7.5
	NX	M4 x 0.7	7	46	30	3.7	11	42	M2.5 x 10	1.0	M3 x 8	0.63	8	4.5
	NM2	ø3.4	7	31	30	3.7	8.5	42	M2.5 x 10	1.0	M3 x 8	0.63	6	4.8
32	NZ	M5 x 0.8	8.5	70	50	4.6	13	60	M3 x 12	1.5	M4 x 12	1.5	14	4.5
	NY	M4 x 0.7	7	70	50	4.6	13	60	M3 x 12	1.5	M4 x 12	1.5	11	4.5
	NW	M5 x 0.8	8.5	70	50	4.6	13	60	M4 x 12	2.5	M4 x 12	1.5	9	4.5
	NU	M5 x 0.8	8.5	70	50	4.6	13	60	M3 x 12	1.5	M4 x 12	1.5	11	4.5
	NT	M5 x 0.8	8.5	70	50	4.6	17	60	M3 x 12	1.5	M4 x 12	1.5	12	8.5
	NM2	M4 x 0.7	8	50	38.2	—	11.5	60	M3 x 12	1.5	M4 x 12	2.7	10	12
63	NZ	M5 x 0.8	9	70	50	4.6	11	60	M4 x 12	3.6	M4 x 12	2.7	14	4.5
	NY	M4 x 0.7	8	70	50	4.6	11	60	M4 x 12	3.6	M4 x 12	2.7	14	4.5
	NW	M5 x 0.8	9	70	50	4.6	11	60	M4 x 12	3.6	M4 x 12	2.7	9	4.5
	NT	M5 x 0.8	9	70	50	4.6	14.5	60	M4 x 12	3.6	M4 x 12	2.7	12	8

Series LEY

Dimensions: Motor Flange Option

Motor mounting position: In-line [Size: 25, 32]

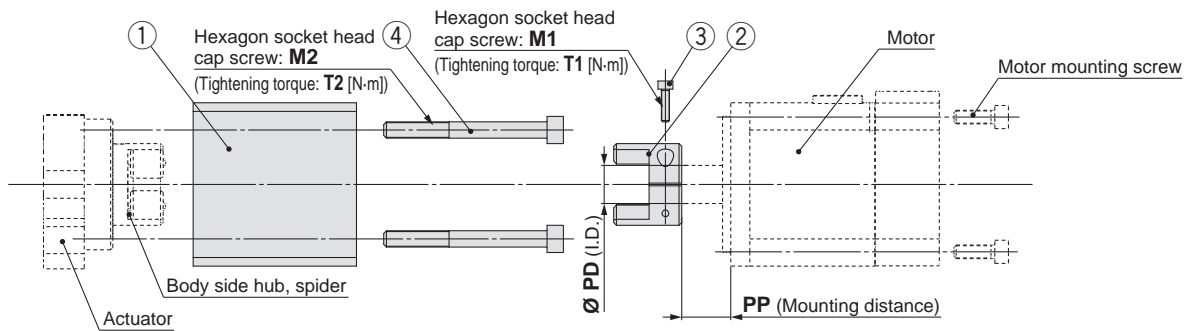

Motor flange details

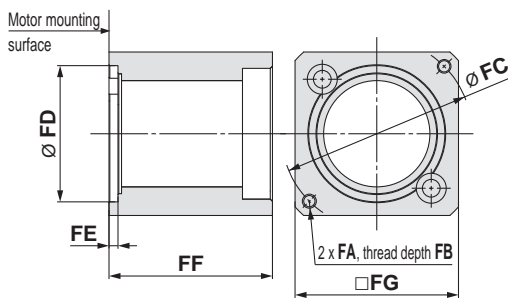

Parts list

No.	Description	Quantity
1	Motor flange	1
2	Motor hub	1
3	Hexagon socket head cap screw (for hub fixing)	1
4	Hexagon socket head cap screw (for motor block mounting)	2

Motor type: NM2

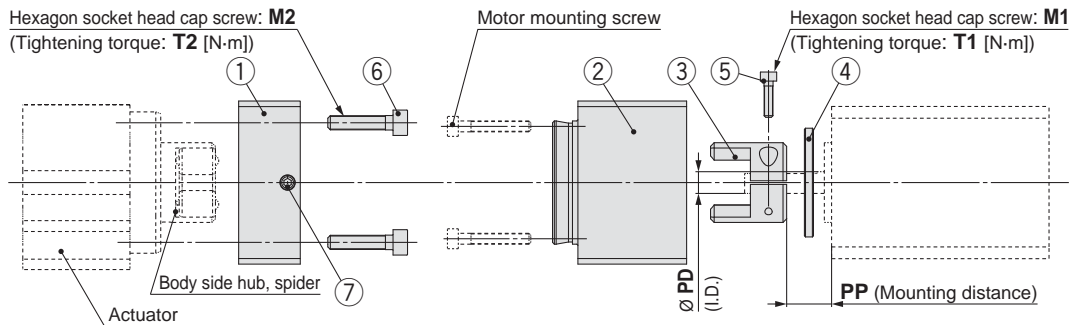

Motor flange B details

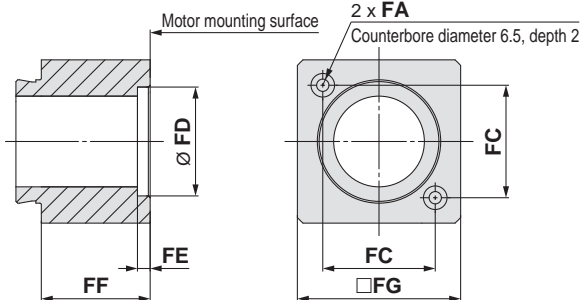

Component Parts

No.	Description	Quantity
1	Motor flange A	1
2	Motor flange B	1
3	Motor hub	1
4	Ring spacer	1
5	Hexagon socket head cap screw (for hub fixing)	1
6	Hexagon socket head cap screw (for motor flange A mounting)	2
7	Hexagon socket head set screw (for motor flange B fixing)	2

Dimensions

Size	Motor type	FA	FB	FC	FD	FE	FF	FG	M1	T1	M2	T2	PD	PP
25	NZ	M4 x 0.7	7.5	46	30	3.7	47	45	M2.5 x 10	1.0	M4 x 40	1.5	8	12.5
	NY	M3 x 0.5	6	45	30	4.2	47	45	M2.5 x 10	1.0	M4 x 40	1.5	8	12.5
	NX	M4 x 0.7	7.5	46	30	3.7	47	45	M2.5 x 10	1.0	M4 x 40	1.5	8	7
	NM2	ø3.4	28	31	30	3.5	50	45	M2.5 x 10	1.0	M4 x 40	1.5	6	12.4
32	NZ	M5 x 0.8	8.5	70	50	3.3	60	60	M3 x 12	1.5	M6 x 60	5.2	14	18
	NY	M4 x 0.7	8	70	50	3.3	60	60	M4 x 12	3.6	M6 x 60	5.2	11	18
	NX	M5 x 0.8	8.5	63	40	3.5	63	60	M4 x 12	3.6	M6 x 60	5.2	9	5
	NW	M5 x 0.8	8.5	70	50	3.3	60	60	M4 x 12	3.6	M6 x 60	5.2	11	12
	NV	M4 x 0.7	8	63	40	3.3	63	60	M4 x 12	3.6	M6 x 60	5.2	9	5
	NU	M5 x 0.8	8.5	70	50	3.3	60	60	M4 x 12	3.6	M6 x 60	5.2	11	12
	NT	M5 x 0.8	8.5	70	50	3.3	60	60	M3 x 12	1.5	M6 x 60	5.2	12	18
NM2	M4 x 0.7	8	50	36	3.3	60	60	M4 x 12	3.6	M6 x 60	5.2	10	3	

Dimensions: Motor Flange Option

Motor mounting position: In-line [Size: 63]

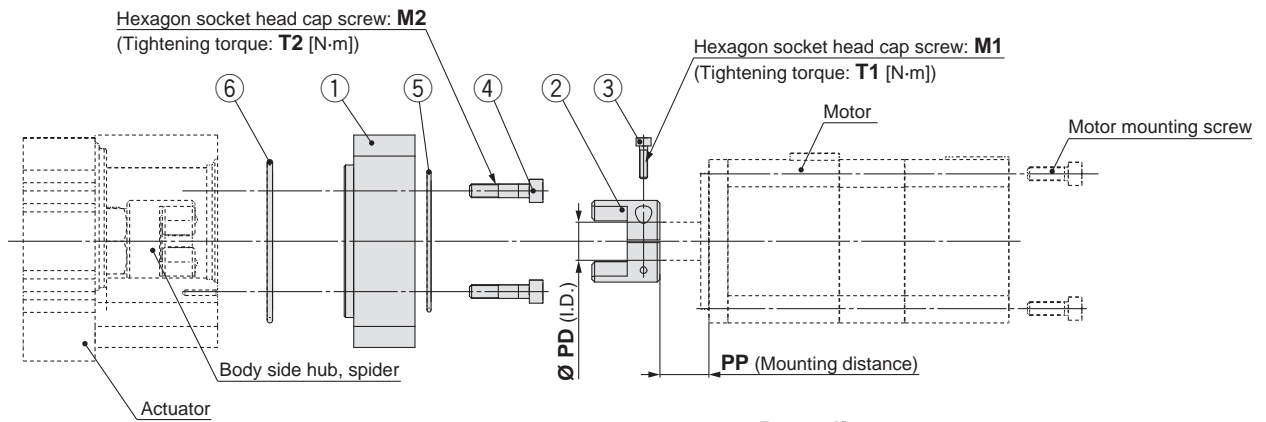

Motor flange details

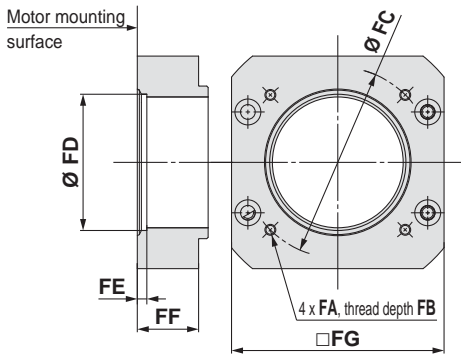

Parts list

No.	Description	Quantity
1	Motor flange	1
2	Motor hub	1
3	Hexagon socket head cap screw (for hub fixing)	1
4	Hexagon socket head cap screw (for motor adapter mounting)	4
5	O-ring (Wire diameter \varnothing 1.5)	1
6	O-ring (Wire diameter \varnothing 2.0)	1

Dimensions

Size	Motor type	FA	FB	FC	FD	FE	FF	FG	M1	T1	M2	T2	PD	PP
63	NZ	M5 x 0.8	10	70	50	3.5	22.5	78	M3 x 12	1.5	M5 x 22	3	14	17.7
	NY	M4 x 0.7	8	70	50	3.5	22.5	78	M3 x 12	3.6	M5 x 22	3	14	17.7
	NX	M5 x 0.8	10	63	40	3.5	27.5	78	M4 x 12	3.6	M5 x 22	3	9	6.7
	NW	M5 x 0.8	10	70	50	3.5	22.5	78	M4 x 12	3.6	M5 x 22	3	9	11.7
	NV	M4 x 0.7	8	63	40	3.5	27.5	78	M4 x 12	3.6	M5 x 22	3	9	6.7
	NU	M5 x 0.8	10	70	50	3.5	22.5	78	M4 x 12	3.6	M5 x 22	3	11	11.7
	NT	M5 x 0.8	10	70	50	3.5	22.5	78	M3 x 12	1.5	M5 x 22	3	12	17.7

Model Selection

LEFS

LEFB

LEJS

LEY

LEYG

Motor Mounting

Solid State Auto Switch Direct Mounting Style

D-M9N(V)/D-M9P(V)/D-M9B(V)



Refer to the SMC website for details about products conforming to the international standards.

Grommet

- 2-wire load current is reduced (2.5 to 40 mA).
- Using flexible cable as standard.



Auto Switch Specifications

PLC: Programmable Logic Controller

D-M9□, D-M9□V (With indicator light)						
Auto switch model	D-M9N	D-M9NV	D-M9P	D-M9PV	D-M9B	D-M9BV
Electrical entry	In-line	Perpendicular	In-line	Perpendicular	In-line	Perpendicular
Wiring type	3-wire			2-wire		
Output type	NPN		PNP		—	
Applicable load	IC circuit, Relay, PLC				24 V DC relay, PLC	
Power supply voltage	5, 12, 24 V DC (4.5 to 28 V)				—	
Current consumption	10 mA or less				—	
Load voltage	28 V DC or less		—		24 V DC (10 to 28 V DC)	
Load current	40 mA or less				2.5 to 40 mA	
Internal voltage drop	0.8 V or less at 10 mA (2 V or less at 40 mA)				4 V or less	
Leakage current	100 μA or less at 24 V DC				0.8 mA or less	
Indicator light	Red LED lights up when turned ON.					
Standards	CE marking, RoHS					

Oilproof Heavy-duty Lead Wire Specifications

Auto switch model		D-M9N(V)	D-M9P(V)	D-M9B(V)
Sheath	Outside diameter [mm]	2.6		
Insulator	Number of cores	3 cores (Brown/Blue/Black)		2 cores (Brown/Blue)
	Outside diameter [mm]	0.88		
Conductor	Effective area [mm ²]	0.15		
	Strand diameter [mm]	0.05		
Minimum bending radius [mm] (Reference value)		17		

Note 1) Refer to the Auto Switch Guide for solid state auto switch common specifications.
Note 2) Refer to the Auto Switch Guide for lead wire lengths.

Caution

Precautions

Fix the auto switch with the screw installed on the auto switch body. The auto switch may be damaged if a screw other than the one supplied is used.

Weight

[g]

Auto switch model		D-M9N(V)	D-M9P(V)	D-M9B(V)
Lead wire length	0.5 m (—)	8	7	7
	1 m (M)	14	13	13
	3 m (L)	41	38	38
	5 m (Z)	68	63	63

Dimensions

[mm]

D-M9□

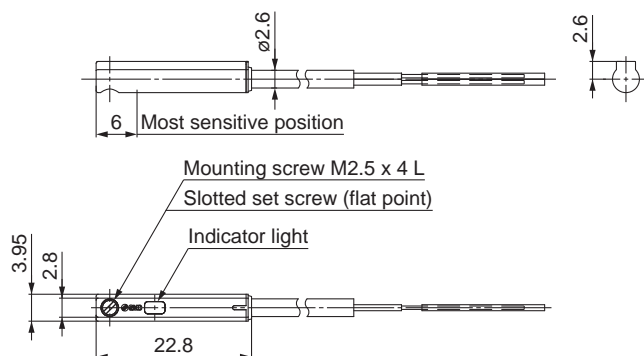

D-M9□V

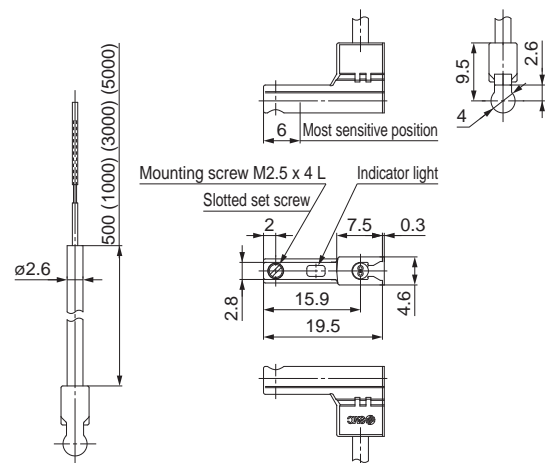

2-Colour Indication Solid State Auto Switch Direct Mounting Style

D-M9NW(V)/D-M9PW(V)/D-M9BW(V)



Refer to the SMC website for details about products conforming to the international standards.

Grommet

- 2-wire load current is reduced (2.5 to 40 mA).
- Using flexible cable as standard.
- The optimum operating range can be determined by the colour of the light. (Red → Green ← Red)



Caution

Precautions

Fix the auto switch with the screw installed on the auto switch body. The auto switch may be damaged if a screw other than the one supplied is used.

Auto Switch Specifications

PLC: Programmable Logic Controller

D-M9□W, D-M9□WV (With indicator light)						
Auto switch model	D-M9NW	D-M9NWV	D-M9PW	D-M9PWV	D-M9BW	D-M9BWV
Electrical entry	In-line	Perpendicular	In-line	Perpendicular	In-line	Perpendicular
Wiring type	3-wire			2-wire		
Output type	NPN		PNP		—	
Applicable load	IC circuit, Relay, PLC				24 V DC relay, PLC	
Power supply voltage	5, 12, 24 V DC (4.5 to 28 V)				—	
Current consumption	10 mA or less				—	
Load voltage	28 V DC or less		—		24 V DC (10 to 28 V DC)	
Load current	40 mA or less				2.5 to 40 mA	
Internal voltage drop	0.8 V or less at 10 mA (2 V or less at 40 mA)				4 V or less	
Leakage current	100 μA or less at 24 V DC				0.8 mA or less	
Indicator light	Operating range Red LED lights up. Optimum operating range Green LED lights up.					
Standards	CE marking, RoHS					

Oilproof Flexible Heavy-duty Lead Wire Specifications

Auto switch model		D-M9NW(V)	D-M9PW(V)	D-M9BW(V)
Sheath	Outside diameter [mm]	2.6		
Insulator	Number of cores	3 cores (Brown/Blue/Black)		2 cores (Brown/Blue)
	Outside diameter [mm]	0.88		
Conductor	Effective area [mm ²]	0.15		
	Strand diameter [mm]	0.05		
Minimum bending radius [mm] (Reference value)		17		

Note 1) Refer to the Auto Switch Guide for solid state auto switch common specifications.
Note 2) Refer to the Auto Switch Guide for lead wire lengths.

Weight

[g]

Auto switch model		D-M9NW(V)	D-M9PW(V)	D-M9BW(V)
Lead wire length	0.5 m (—)	8	—	7
	1 m (M)	14	—	13
	3 m (L)	41	—	38
	5 m (Z)	68	—	63

Dimensions

[mm]

D-M9□W

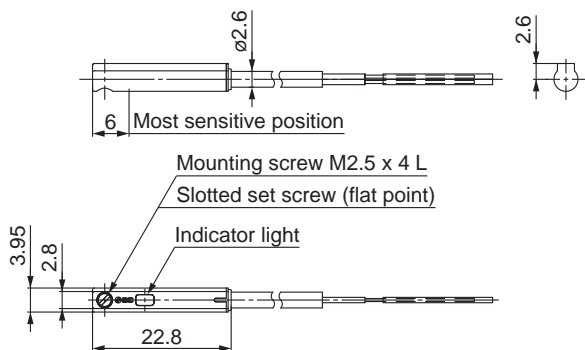

D-M9□WV

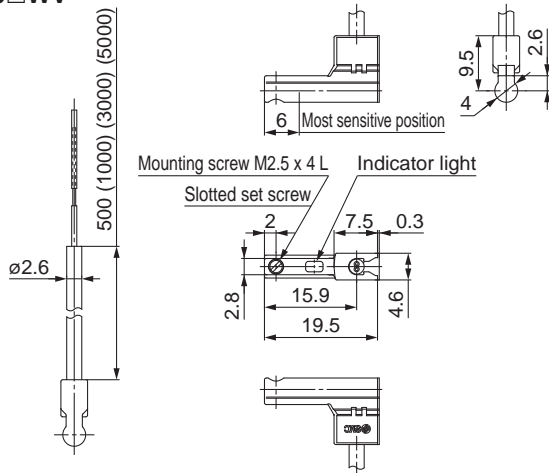

Model Selection
 LEFS
 LEFB
 LEJS
 LEY
 LEYG
 Motor Mounting

Water Resistant 2-Colour Indication Solid State Auto Switch: Direct Mounting Style

D-M9NA(V)/D-M9PA(V)/D-M9BA(V)



Refer to the SMC website for details about products conforming to the international standards.

Auto Switch Specifications

PLC: Programmable Logic Controller

D-M9□A, D-M9□AV (With indicator light)						
Auto switch model	D-M9NA	D-M9NAV	D-M9PA	D-M9PAV	D-M9BA	D-M9BAV
Electrical entry	In-line	Perpendicular	In-line	Perpendicular	In-line	Perpendicular
Wiring type	3-wire			2-wire		
Output type	NPN		PNP		—	
Applicable load	IC circuit, Relay, PLC				24 VDC relay, PLC	
Power supply voltage	5, 12, 24 VDC (4.5 to 28 V)				—	
Current consumption	10 mA or less				—	
Load voltage	28 VDC or less		—		24 VDC (10 to 28 VDC)	
Load current	40 mA or less				2.5 to 40 mA	
Internal voltage drop	0.8 V or less at 10 mA (2 V or less at 40 mA)				4 V or less	
Leakage current	100 μA or less at 24 VDC				0.8 mA or less	
Indicator light	Operating range Red LED lights up. Optimum operating range Green LED lights up.					
Standards	CE marking, RoHS					

Grommet

- Water (coolant) resistant type
- 2-wire load current is reduced (2.5 to 40 mA).
- The optimum operating range can be determined by the colour of the light. (Red → Green ← Red)
- Using flexible cable as standard.



Caution

Precautions

Fix the auto switch with the screw installed on the auto switch body. The auto switch may be damaged if a screw other than the one supplied is used. Please consult with SMC if using coolant liquid other than water based solution.

Weight

Auto switch model		D-M9NA(V)	D-M9PA(V)	D-M9BA(V)
Lead wire length	0.5 m (—)	8	7	7
	1 m (M)	14	13	13
	3 m (L)	41	38	38
	5 m (Z)	68	63	63

[g]

Oilproof Flexible Heavy-duty Lead Wire Specifications

Auto switch model		D-M9NA□	D-M9NAV□	D-M9PA□	D-M9PAV□	D-M9BA□	D-M9BAV□
Sheath	Outside diameter [mm]	2.6	2.7 X 3.2 (ellipse)	2.6	2.7 X 3.2 (ellipse)	2.6	2.6
Insulator	Number of cores	3 cores (Brown/Blue/Black)				2 cores (Brown/Blue)	
	Outside diameter [mm]	0.88	0.9	0.88	0.9	0.88	0.88
Conductor	Effective area [mm ²]	0.15					
	Strand diameter [mm]	0.05					
Minimum bending radius [mm] (Reference value)		17	20	17	20	17	17

Note 1) Refer to the Auto SWitch Guide for solid state auto switch common specifications.
Note 2) Refer to the Auto SWitch Guide for lead wire lengths.

Dimensions

[mm]

D-M9□A

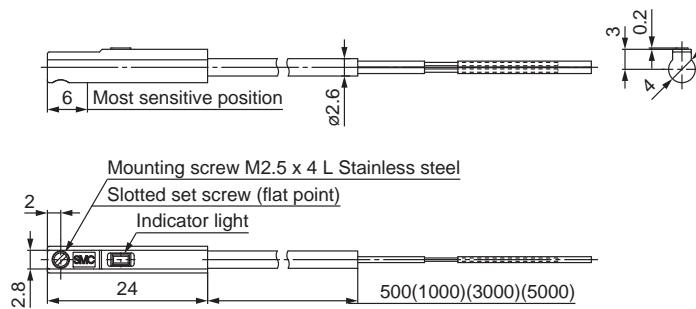

D-M9NAV□/D-M9PAV□

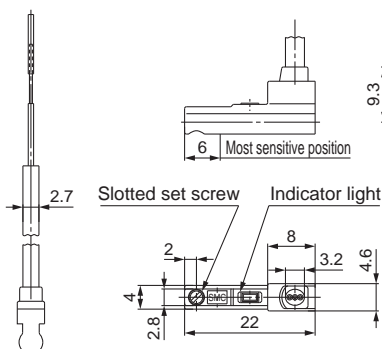

D-M9BAV□

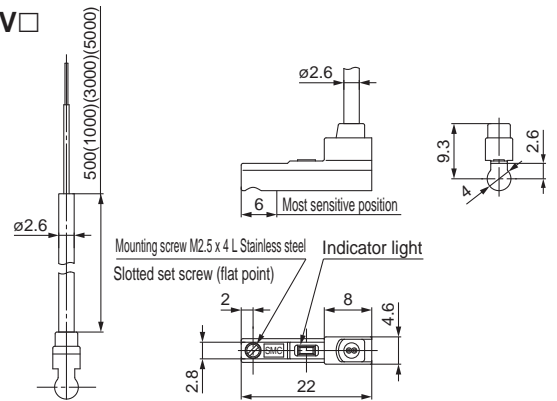



Series LEY/LEYG Electric Actuators Specific Product Precautions 1

Be sure to read this before handling. Refer to the back cover for Safety Instructions. For Electric Actuator Precautions, refer to “Handling Precautions for SMC Products” and the Operation Manual on the SMC website, <http://www.smc.eu>

Design/Selection

Warning

- Do not apply a load in excess of the specification limits.**
Select a suitable actuator by work load and allowable lateral load on the rod end. If the product is used outside of the specification limits, the eccentric load applied to the piston rod will be excessive and have adverse effects such as creating play on the sliding parts of the piston rod, degrading accuracy and shortening the life of the product.
- Do not use the product in applications where excessive external force or impact force is applied to it.**
This can cause a failure.
- When used as a stopper, select the LEYG series “Sliding bearing” for a stroke of 30 mm or less.**
- When used as a stopper, fix the main body with a guide attachment (“Top mounting” or “Bottom mounting”).**
If the end of the actuator is used to fix the main body (end mounting), the excessive load acts on the actuator, which adversely affects the operation and life of the product.

Handling

Caution

- When using the pushing operation, be sure to set to force/speed control, and use within the specified pushing speed range for each series.**
Do not allow the piston rod to hit the workpiece and end of the stroke in the position control. The lead screw, bearing and internal stopper may be damaged and lead to malfunction.
- For pushing operation, the maximum torque value of the motor to be used should be set to less than 90 % of the rated torque of the reference motor. For the LEY63, less than 150 %.**
It may lead to damage and malfunction.
- The maximum speed of this actuator is affected by the product stroke.**
Check the model selection section of the catalogue.
- Do not apply a load, impact or resistance in addition to the transferred load during return to origin.**
Additional force will cause the displacement of the origin position.
- Do not scratch or dent the sliding parts of the piston rod, by striking or attaching objects.**
The piston rod and guide rod are manufactured to precise tolerances, even a slight deformation may cause a malfunction.
- When an external guide is used, connect it in such a way that no impact or load is applied to it.**
Use a freely moving connector (such as a floating joint).
- Do not operate with the piston rod fixed and the actuator body moving.**
Excessive load will be applied to the piston rod, leading to damage to the actuator and reducing the life of the product.

Handling

Caution

- When an actuator is operated with one end fixed and the other free (ends tapped or flange type), a bending moment may act on the actuator due to vibration generated at the stroke end, which can damage the actuator. In such a case, install a mounting bracket to suppress the vibration of the actuator body or reduce the speed so that the actuator does not vibrate at the stroke end.**
Also, use a mounting bracket when moving the actuator body or when a long stroke actuator is mounted horizontally and fixed at one end.
- Avoid using the electric actuator in such a way that rotational torque would be applied to the piston rod.**
This may cause deformation of the non-rotating guide, abnormal responses of the auto switch, play in the internal guide or an increase in the sliding resistance.
Refer to the table below for the approximate values of the allowable range of rotational torque.

Allowable rotational torque [N·m] or less	LEY25□	LEY32	LEY63
	1.1	1.4	2.8

When screwing in a bracket or nut to the piston rod end, hold the flats of the end of the “socket” with a spanner (the piston rod should be fully retracted). Do not apply tightening torque to the non-rotating mechanism.

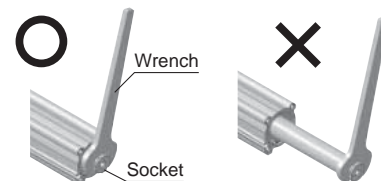

- When using auto switch with the guide rod type LEYG series, the following limitations will apply. Please select the product while paying attention to this.**
 - Insert the auto switch from the front side with the rod (plate) extended.
 - The auto switches with perpendicular electrical entry cannot be used.
 - For the parts hidden behind the guide attachment (Rod end), the auto switch cannot be fixed.
 - Please consult with SMC when using auto switch at the rod end.

Enclosure

IP - □ □

First characteristic numeral ● Second characteristic numeral

- First Characteristics: Degrees of protection against solid foreign objects

0	Non-protected
1	Protected against solid foreign objects of 50 mm Ø and greater
2	Protected against solid foreign objects of 12 mm Ø and greater
3	Protected against solid foreign objects of 2.5 mm Ø and greater
4	Protected against solid foreign objects of 1.0 mm Ø and greater
5	Dust-protected
6	Dust-tight



Series LEY/LEYG

Electric Actuators

Specific Product Precautions 2

Be sure to read this before handling. Refer to the back cover for Safety Instructions. For Electric Actuator Precautions, refer to "Handling Precautions for SMC Products" and the Operation Manual on the SMC website, <http://www.smc.eu>

Enclosure

● Second Characteristics: Degrees of protection against water

0	Non-protected	—
1	Protected against vertically falling water drops	Dripproof type 1
2	Protected against vertically falling water drops when enclosure tilted up to 15°	Dripproof type 2
3	Protected against rainfall when enclosure tilted up to 60°	Rainproof
4	Protected against splashing water	Splashproof
5	Protected against water jets	Water-proof
6	Protected against powerful water jets	Powerful water-proof
7	Protected against the effects of temporary immersion in water	Immersible
8	Protected against the effects of continuous immersion in water	Submersible

Example) IP65: Dust-tight, Water-proof type
 "Water-tproof type" means that no water intrudes inside an equipment that could hinder from operating normally by means of applying water for 3 minutes in the prescribed manner. Take appropriate protection measures, since a device is not usable in an environment where a droplet of water is splashed constantly.

Mounting

⚠ Caution

- When mounting workpieces or jigs to the piston rod end "socket," hold the flats of the "socket" with a spanner so that the piston rod does not rotate. The screw should be tightened within the specified torque range.

This may cause abnormal responses of the auto switch, play in the internal guide or an increase in the sliding resistance.

- When mounting the product and/or a workpiece, tighten the mounting screws within the specified torque range.

Tightening the screws with a higher torque than recommended may cause a malfunction, whilst the tightening with a lower torque can cause the displacement of the mounting position or in extreme conditions the actuator could become detached from its mounting position.

<Series LEY>

Workpiece fixed/Rod end female thread

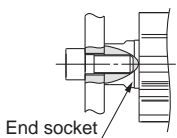

Model	Screw size	Max. tightening torque [N·m]	Max. screw-in depth [mm]	End socket width across flats [mm]
LEY25	M8 x 1.25	12.5	13	17
LEY32	M8 x 1.25	12.5	13	22
LEY63	M16 x 2	106	21	36

Workpiece fixed/Rod end male thread (When "Rod end male thread" is selected.)

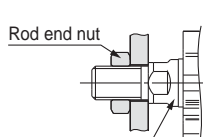

Model	Thread size	Max. tightening torque [N·m]	Effective thread length [mm]	End socket width across flats [mm]
LEY25	M14 x 1.5	65.0	20.5	17
LEY32	M14 x 1.5	65.0	20.5	22
LEY63	M18 x 1.5	97.0	26	36

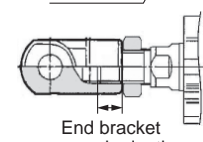

Model	Rod end nut		End bracket screw-in depth [mm]
	Width across flats [mm]	Length [mm]	
LEY25	22	8	8 or more
LEY32	22	8	8 or more
LEY63	27	11	11 or more

* Rod end nut is an accessory.

Mounting

⚠ Caution

Body fixed/Body bottom tapped style (When "Body bottom tapped" is selected.)

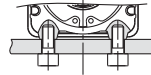

Model	Screw size	Max. tightening torque [N·m]	Max. screw-in depth [mm]
LEY25	M5 x 0.8	3.0	6.5
LEY32	M6 x 1.0	5.2	8.8
LEY63	M8 x 1.25	12.5	10

Body fixed/Rod side/Head side tapped style

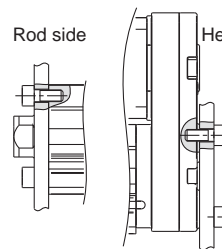

Model	Screw size	Max. tightening torque [N·m]	Max. screw-in depth [mm]
LEY25	M5 x 0.8	3.0	8
LEY32	M6 x 1.0	5.2	10
LEY63	M8 x 1.25	12.5	14

* Except the LEY□□

<Series LEYG>

Workpiece fixed/Plate tapped style

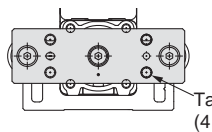

Model	Screw size	Max. tightening torque [N·m]	Max. screw-in depth [mm]
LEYG25 ^M _L	M6 x 1.0	5.2	11
LEYG32 ^M _L	M6 x 1.0	5.2	12

Body fixed/Top mounting

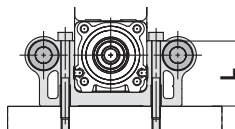

Model	Screw size	Max. tightening torque [N·m]	Length: L [mm]
LEYG25 ^M _L	M5 x 0.8	3.0	40.5
LEYG32 ^M _L	M5 x 0.8	3.0	50.5

Body fixed/Bottom mounting

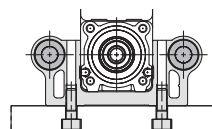

Model	Screw size	Max. tightening torque [N·m]	Max. screw-in depth [mm]
LEYG25 ^M _L	M6 x 1.0	5.2	12
LEYG32 ^M _L	M6 x 1.0	5.2	12

Body fixed/Head side tapped style

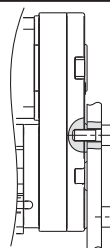

Model	Screw size	Max. tightening torque [N·m]	Max. screw-in depth [mm]
LEYG25 ^M _L	M5 x 0.8	3.0	8
LEYG32 ^M _L	M6 x 1.0	5.2	10



Series LEY/LEYG Electric Actuators Specific Product Precautions 3

Be sure to read this before handling. Refer to the back cover for Safety Instructions. For Electric Actuator Precautions, refer to “Handling Precautions for SMC Products” and the Operation Manual on the SMC website, <http://www.smc.eu>

Mounting

⚠ Caution

- Keep the flatness of the mounting surface within the following ranges when mounting the actuator body and workpiece.

Unevenness of a workpiece or base mounted on the body of the product may cause an increase in the sliding resistance.

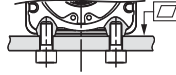
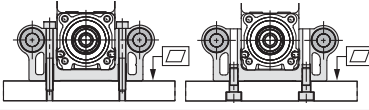
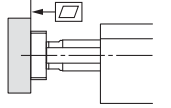
Model	Mounting position	Flatness
LEY□	Body/Body bottom 	0.1 mm or less
LEYG□	Top mounting/Bottom mounting 	0.05 mm or less
	Workpiece/Plate mounting 	0.05 mm or less

Maintenance

⚠ Warning

- Ensure that the power supply is off and the workpiece is removed before performing maintenance or replacement of the product.

● Maintenance frequency

Perform maintenance according to the table below.

Frequency	Appearance check	Belt check
Inspection before daily operation	○	—
Inspection every 6 months/ 250 km/5 million cycles*	○	○

* Select whichever comes first.

● Items for visual appearance check

- Loose set screws, Abnormal dirt
- Check of flaw and cable joint
- Vibration, Noise

● Items for belt check

Stop operation immediately and replace the belt when signs of belt wear appear, as described below. Further, ensure the operating environment and conditions satisfy the requirements specified for the product.

a. Tooth shape canvas is worn.

Canvas fiber becomes fuzzy. Rubber is removed and the fiber becomes whitish. Lines of fibers become unclear.

b. Peeling off or wearing of the side of the belt

Belt corner becomes round and frayed thread sticks out.

c. Belt partially cut

Belt is partially cut. Foreign objects caught in teeth other than cut part causes flaw.

d. Vertical line of belt teeth

Flaw which is produced when the belt runs on the flange.

e. Rubber back of the belt is softened and sticky.



f. Crack on the back of the belt

- For the IP65 equivalent type, apply grease on the piston rod periodically. Grease should be applied at 1 million cycles or 200 km, whichever comes first.

· Grease pack order number: GR-S-010 (10 g)/GR-S-020 (20 g)

Safety Instructions

These safety instructions are intended to prevent hazardous situations and/or equipment damage. These instructions indicate the level of potential hazard with the labels of “**Caution**,” “**Warning**” or “**Danger**.” They are all important notes for safety and must be followed in addition to International Standards (ISO/IEC)*1), and other safety regulations.

-  **Caution:** **Caution** indicates a hazard with a low level of risk which, if not avoided, could result in minor or moderate injury.
-  **Warning:** **Warning** indicates a hazard with a medium level of risk which, if not avoided, could result in death or serious injury.
-  **Danger:** **Danger** indicates a hazard with a high level of risk which, if not avoided, will result in death or serious injury.

- *1) ISO 4414: Pneumatic fluid power – General rules relating to systems.
- ISO 4413: Hydraulic fluid power – General rules relating to systems.
- IEC 60204-1: Safety of machinery – Electrical equipment of machines. (Part 1: General requirements)
- ISO 10218-1: Manipulating industrial robots - Safety. etc.

Warning

1. The compatibility of the product is the responsibility of the person who designs the equipment or decides its specifications.

Since the product specified here is used under various operating conditions, its compatibility with specific equipment must be decided by the person who designs the equipment or decides its specifications based on necessary analysis and test results. The expected performance and safety assurance of the equipment will be the responsibility of the person who has determined its compatibility with the product. This person should also continuously review all specifications of the product referring to its latest catalogue information, with a view to giving due consideration to any possibility of equipment failure when configuring the equipment.

2. Only personnel with appropriate training should operate machinery and equipment.

The product specified here may become unsafe if handled incorrectly. The assembly, operation and maintenance of machines or equipment including our products must be performed by an operator who is appropriately trained and experienced.

3. Do not service or attempt to remove product and machinery/equipment until safety is confirmed.

1. The inspection and maintenance of machinery/equipment should only be performed after measures to prevent falling or runaway of the driven objects have been confirmed.
2. When the product is to be removed, confirm that the safety measures as mentioned above are implemented and the power from any appropriate source is cut, and read and understand the specific product precautions of all relevant products carefully.
3. Before machinery/equipment is restarted, take measures to prevent unexpected operation and malfunction.

4. Contact SMC beforehand and take special consideration of safety measures if the product is to be used in any of the following conditions.

1. Conditions and environments outside of the given specifications, or use outdoors or in a place exposed to direct sunlight.
2. Installation on equipment in conjunction with atomic energy, railways, air navigation, space, shipping, vehicles, military, medical treatment, combustion and recreation, or equipment in contact with food and beverages, emergency stop circuits, clutch and brake circuits in press applications, safety equipment or other applications unsuitable for the standard specifications described in the product catalogue.
3. An application which could have negative effects on people, property, or animals requiring special safety analysis.
4. Use in an interlock circuit, which requires the provision of double interlock for possible failure by using a mechanical protective function, and periodical checks to confirm proper operation.

Limited warranty and Disclaimer/ Compliance Requirements

The product used is subject to the following “Limited warranty and Disclaimer” and “Compliance Requirements”.

Read and accept them before using the product.

Limited warranty and Disclaimer

1. The warranty period of the product is 1 year in service or 1.5 years after the product is delivered, whichever is first.*2) Also, the product may have specified durability, running distance or replacement parts. Please consult your nearest sales branch.
2. For any failure or damage reported within the warranty period which is clearly our responsibility, a replacement product or necessary parts will be provided. This limited warranty applies only to our product independently, and not to any other damage incurred due to the failure of the product.
3. Prior to using SMC products, please read and understand the warranty terms and disclaimers noted in the specified catalogue for the particular products.

*2) Vacuum pads are excluded from this 1 year warranty.

A vacuum pad is a consumable part, so it is warranted for a year after it is delivered. Also, even within the warranty period, the wear of a product due to the use of the vacuum pad or failure due to the deterioration of rubber material are not covered by the limited warranty.

Compliance Requirements

1. The use of SMC products with production equipment for the manufacture of weapons of mass destruction (WMD) or any other weapon is strictly prohibited.
2. The exports of SMC products or technology from one country to another are governed by the relevant security laws and regulations of the countries involved in the transaction. Prior to the shipment of a SMC product to another country, assure that all local rules governing that export are known and followed.

Caution

1. The product is provided for use in manufacturing industries.

The product herein described is basically provided for peaceful use in manufacturing industries.

If considering using the product in other industries, consult SMC beforehand and exchange specifications or a contract if necessary.

If anything is unclear, contact your nearest sales branch.

Caution

SMC products are not intended for use as instruments for legal metrology.

Measurement instruments that SMC manufactures or sells have not been qualified by type approval tests relevant to the metrology (measurement) laws of each country. Therefore, SMC products cannot be used for business or certification ordained by the metrology (measurement) laws of each country.

Safety Instructions

Be sure to read “Handling Precautions for SMC Products” (M-E03-3) before using.