



# ISO Cylinder Series **CP95**

ø32, ø40, ø50, ø63, ø80, ø100

Dimensions conform to ISO 6431, VDMA 24562, CETOP RP43P.



Quick Reference  
Guide

C55

C85

C76

**CP95**

C95

-X  
(Made to Order)

D-  
(Auto Switch)

Model Selection  
Procedures

# Series CP95

## Model Selection

Execution	Model	Bore Size						Adjustable Stroke End Cushioning	Options Piston Rod			
		32	40	50	63	80	100		Standard Hard Chrome	W	R	K
Standard Type	CP95 SB	●	●	●	●	●	●	●	●	○	○	○
	CP95 SDB	●	●	●	●	●	●	●	●	○	○	○
Non-Rotating Piston Rod	CP95 KB	●	●	●	●	●	●	●	—	○	●	—
	CP95 KDB	●	●	●	●	●	●	●	—	○	●	—
With Lock	CP95 NB	●	●	●	●	●	●	●	●	○	—	—
	CP95 NDB	●	●	●	●	●	●	●	●	○	—	—
With Positioner	CP95PB	—	—	●	●	●	●	●	●	—	—	—
	CP95 PDB	—	—	●	●	●	●	●	●	—	—	—
Low Friction Cylinder	CP95 QB <sup>-CA</sup> <sub>-CB</sub>	●	●	●	●	●	●	—	●	—	○	○
	CP95 QDB <sup>-CA</sup> <sub>-CB</sub>	●	●	●	●	●	●	—	●	—	○	○

W = Double/Through Rod

R = Stainless Steel Piston Rod

K = Stainless & Acid-Proof Piston Rod & Nickel Plated Tie Rods

○ Options  
● Standard

# ISO Cylinder/Standard: Double Acting

# Series CP95

ø32, ø40, ø50, ø63, ø80, ø100

## How to Order

**Standard** CP95SD **B** **32** — **100** **W** — **Z76** **S**

**Built-in magnet** — **Mounting** — **Bore size** — **Auto switch** — **Number of auto switches** — **Stroke (mm)**

Mounting	
B	Basic/Without bracket
L	Axial foot
F	Front flange
G	Rear flange
C	Single rear clevis
D	Double rear clevis

Bore size	
32	32mm
40	40mm
50	50mm
63	63mm
80	80mm
100	100mm

Auto switch	
—	Without auto switch
S	1
3	3
n	n

\* Refer to table below for selection of applicable auto switch.

Rod Specifications	
—	Hard chromed rod as standard
W	Double/through rod
R	Stainless steel piston rod
K	stainless steel and acid-proof piston rod
F	Rod boot

Refer to standard stroke table on p.5-4

### Applicable Auto Switches/Direct mounting type

Type	Special function	Electrical entry	Indicator light	Wiring (output)	Load voltage		Auto switch model		Lead wire length (m) <sup>Note)</sup>			Applicable load	Mounting bracket	
					DC	AC	Electrical entry direction		0.5 (Nil)	3 (L)	5 (Z)			
							Vertical	Lateral						
Reed switch	—	Grommet	Yes	3 wire	—	5V	—	Z76	●	●	—	IC circuit	—	
				2 wire	24V	100V	—	Z73	●	●	●	—		Relay PLC
Solid state switch	—	Grommet	Yes	3 wire (NPN)	24V	5V, 12V	—	Y69A	Y59A	●	●	○	IC circuit	BMP1-032
				3 wire (PNP)		12V		Y7PV	Y7P	●	●	○	—	
				2 wire	5V, 12V	Y69B	Y59B	●	●	○	—			
				3 wire (NPN)		Y7NWV	Y7NW	●	●	○	IC circuit			
				3 wire (PNP)		Y7PWV	Y7PW	●	●	○	—			
				Water resistant (2 colour indicator)	2 wire	12V	Y7BWV	Y7BW	●	●	○	—		
	—	Connector and Grommet	Yes	3 wire (NPN)	24V	5V, 12V	—	M9NV	M9N	●	●	○	IC circuit	
3 wire (PNP)				M9PV				M9P	●	●	○			
2 wire				M9BV				M9B	●	●	○			

\* Lead wire length 0.5m..... — (Example: A53)  
 3m..... L (Example: A53L)  
 5m..... Z (Example: A53Z)

○: Manufactured upon receipt of order.

### Auto Switch Mounting Accessories for D-M9

Bore size (mm)	Order No.
ø32~ø100	<b>BMP1-032</b>
	<b>BMG2-012</b>

Note: For the mounting of auto switch D-M9, both BMP1-032 and BMG2-012 are necessary.

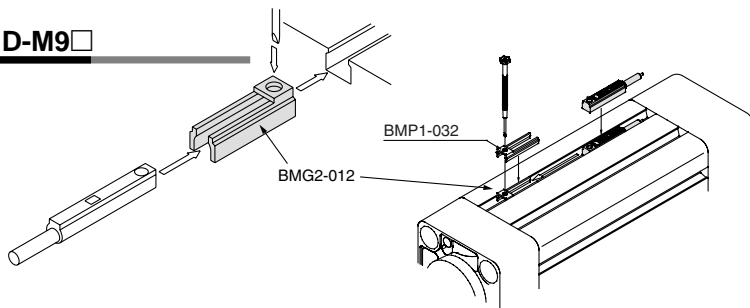

# Series CP95



ISO Symbol  
Double acting

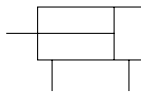

## Minimum Strokes for Auto Switch Mounting

Refer to p.5-32 for "Minimum Strokes for Auto Switch Mounting".

## Specifications

Bore size	ø32	ø40	ø50	ø63	ø80	ø100
Action	Double acting					
Fluid	Air					
Proof pressure	1.5MPa					
Max. operating pressure	1.0MPa					
Min. operating pressure	0.05MPa					
Ambient and fluid temperature	Without magnet -10 to 70°C (No freezing)					
	With magnet -10 to 60°C (No freezing)					
Lubrication	Not required (Non-lube)					
Operating piston speed	50 to 1000mm/s					
Allowable stroke tolerance	to 250: $^{+1.0}_0$ , 251 to 1000: $^{+1.4}_0$					
Cushion	Both ends (Air cushion)					
Port size	G1/8	G1/4	G1/4	G3/8	G3/8	G1/2
Mounting	Basic, axial foot, front flange, rear flange, spherical bearing, single rear clevis, double rear clevis					

## Standard Stroke

Bore size (mm)	Standard stroke (mm)	Max. * stroke
32	25, 50, 80, 100, 125, 160, 200, 250, 320, 400, 500	700
40	25, 50, 80, 100, 125, 160, 200, 250, 320, 400, 500	800
50	25, 50, 80, 100, 125, 160, 200, 250, 320, 400, 500, 600	1000
63	25, 50, 80, 100, 125, 160, 200, 250, 320, 400, 500, 600	1000
80	25, 50, 80, 100, 125, 160, 200, 250, 320, 400, 500, 600	1000
100	25, 50, 80, 100, 125, 160, 200, 250, 320, 400, 500, 600	1000

Intermediate strokes are available.

\* Please consult with SMC for longer strokes.

## Mounting Bracket, Mounting Accessories

Description	Bore size	ø32	ø40	ø50	ø63	ø80	ø100
L	Foot <sup>(1)</sup>	L5032	L5040	L5050	L5063	L5080	L5100
F,G	Flange	F5032	F5040	F5050	F5063	F5080	F5100
C	Single rear clevis	C5032	C5040	C5050	C5063	C5080	C5100
D	Double rear clevis	D5032	D5040	D5050	D5063	D5080	D5100
DS	Double rear clevis (for ES accessory)	DS5032	DS5040	DS5050	DS5063	DS5080	DS5100
ES	Angled rear clevis with ball joint	ES5032	ES5040	ES5050	ES5063	ES5080	ES5100
E	Angled rear clevis	E5032	E5040	E5050	E5063	E5080	E5100
GKM	Rod clevis	GKM10-20	GKM12-24	GKM16_32	GKM16-32	GKM20-40	GKM20-40
KJ	Piston rod ball joint	KJ10D	KJ12D	KJ16D	KJ16D	KJ20D	KJ20D
JA	Floating joint	JA30-10-125	JA40-12-125	JA50-16-150	JA50-16-150	JAH50-20-150	JAH50-20-150

Note 1) Two foot brackets required for one cylinder.

Note 2) Accessories for each mounting bracket are as follows.

Foot, Flange, Single clevis: Mounting bolts

Double rear clevis: (D,DS): Clevis pin

Note 3) GKM according to ISO 8140

Note 4) KJ according to ISO 8139

Note 5) Piston rod nut is standard

## Theoretical Force



Bore size (mm)	Rod diameter (mm)	Operating direction	Piston area (mm <sup>2</sup> )	Operating pressure (MPa)								
				0.2	0.3	0.4	0.5	0.6	0.7	0.8	0.9	1.0
32	12	OUT	804	161	241	322	402	482	563	643	724	804
		IN	691	138	207	276	346	415	484	553	622	691
40	16	OUT	1257	251	377	503	629	754	880	1006	1131	1257
		IN	1056	211	317	422	528	634	739	845	950	1056
50	20	OUT	1963	393	589	785	982	1178	1374	1570	1767	1963
		IN	1649	330	495	660	825	989	1154	1319	1484	1649
63	20	OUT	3117	623	935	1247	1559	1870	2182	2494	2805	3117
		IN	2803	561	841	1121	1402	1682	1962	2242	2523	2803
80	25	OUT	5027	1005	1508	2011	2514	3016	3519	4022	4524	5027
		IN	4536	907	1361	1814	2268	2722	3175	3629	4082	4536
100	30	OUT	7854	1571	2356	3142	3927	4712	5498	6283	7068	7854
		IN	7147	1429	2144	2859	3574	4288	5003	5718	6432	7147

(Note) Theoretical force(N) = Pressure (MPa) X Piston area (mm<sup>2</sup>)

## Allowable Kinetic Energy

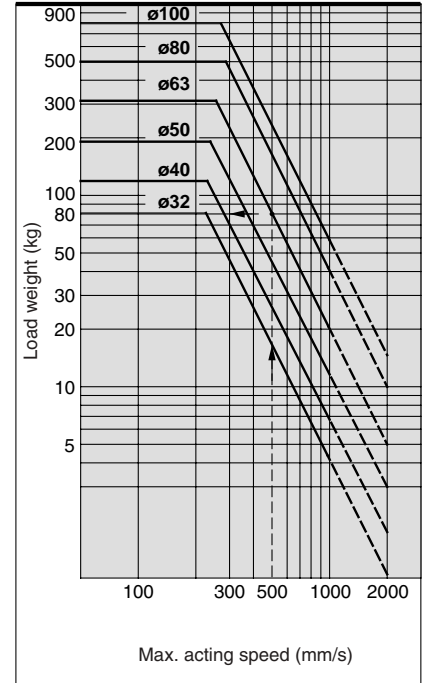

Example: Load limit at rod end when air cylinder ø63 is actuated with max. actuating speed 500mm/s. See the intersection of lateral axis 500mm/s and ø63 line, and extend the intersection to left. Thus the allowable load is 80kg.

## Weight table

[kg]

Ø Bore	Mounting type	32	40	50	63	80	100
Basic weight	Basic type B	0.59	0.87	1.44	2.00	3.37	4.45
	Foot L	0.16	0.20	0.38	0.46	0.89	1.09
	Front/rear flange F	0.20	0.23	0.47	0.58	1.30	1.81
	Male rear clevis C	0.16	0.23	0.37	0.60	1.07	1.73
	Female rear clevis D	0.20	0.32	0.45	0.71	1.28	2.11
	Angled rear clevis E	0.16	0.22	0.42	0.52	0.94	1.40
	Female rear clevis DS	0.17	0.27	0.45	0.64	1.37	2.05
	Spherical bearing ES	0.18	0.27	0.46	0.55	0.97	1.33
Additional weight per 50 mm stroke		0.11	0.17	0.28	0.40	0.67	0.89
Accessories	Piston rod ball joint KJ	0.15	0.23	0.26	0.26	0.60	0.83
	Rod clevis GKM	0.22	0.37	0.43	0.43	0.87	1.27
	Floating joint JA	0.015	0.20	0.26	0.26	0.9	0.9

## Weight calculation method

Example: CP95S32-100  
(basic Ø32, 100st)

- Basic weight . . . . .0.59kg (Standard Ø32)
- Additional weight . .0.11kg/50mm stroke
- Cylinder stroke . . .100st

Cylinder weight =  
0.59+(0.11 x 100/50)=0.81kg

# Series CP95

## Construction

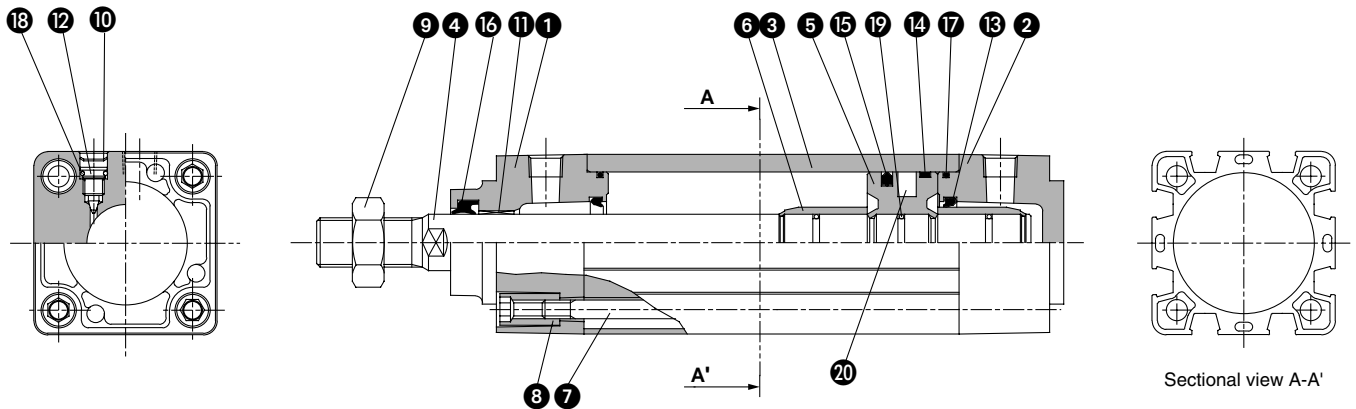

### Parts list

No.	Description	Material
①	Head cover	Die-cast aluminum
②	End cover	Die-cast aluminum
③	Cylinder tube	Die-cast aluminum
④	Piston rod	Hard chromed steel C45
⑤	Piston	Die-cast aluminum
⑥	Cushion ring	Brass
⑦	Tie rod	Steel, zinc chromate plated
⑧	Tie rod nut	Steel, zinc chromate plated
⑨	Rod end nut	Steel, zinc chromate plated
⑩	Snap ring	Steel nickel plated
⑪	Bushing	Lead-bronze casting
⑫	Cushion valve	Steel, zinc chromate plated
⑬	Cushion seal	Elastomer
⑭	Wear ring	Antifriction material
⑮	Piston seal	NBR
⑯	Rod seal	NBR
⑰	Cylinder tube gasket	NBR
⑱	Cushioning valve seal	NBR
⑲	Piston/rod gasket	NBR
⑳	Magnet ring	

### Replacement parts: Seal kits

Ø32 includes order No. from ⑬ to ⑰,

Ø40 - Ø100 includes from ⑫ to ⑱

Ø	Order No.
32	CS95-32
40	CS95-40
50	CS95-50
63	CS95-63
80	CS95-80
100	CS95-100

## Without Mounting Bracket

### CP95SB $\emptyset$ -Stroke

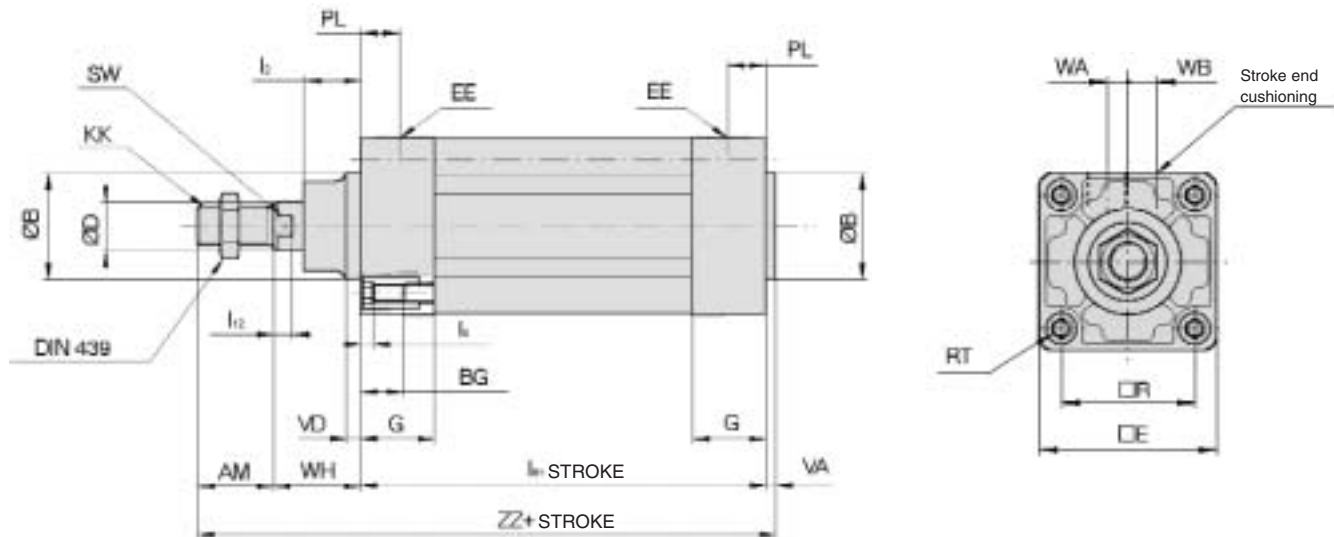

### CP95SB $\emptyset$ -Stroke W

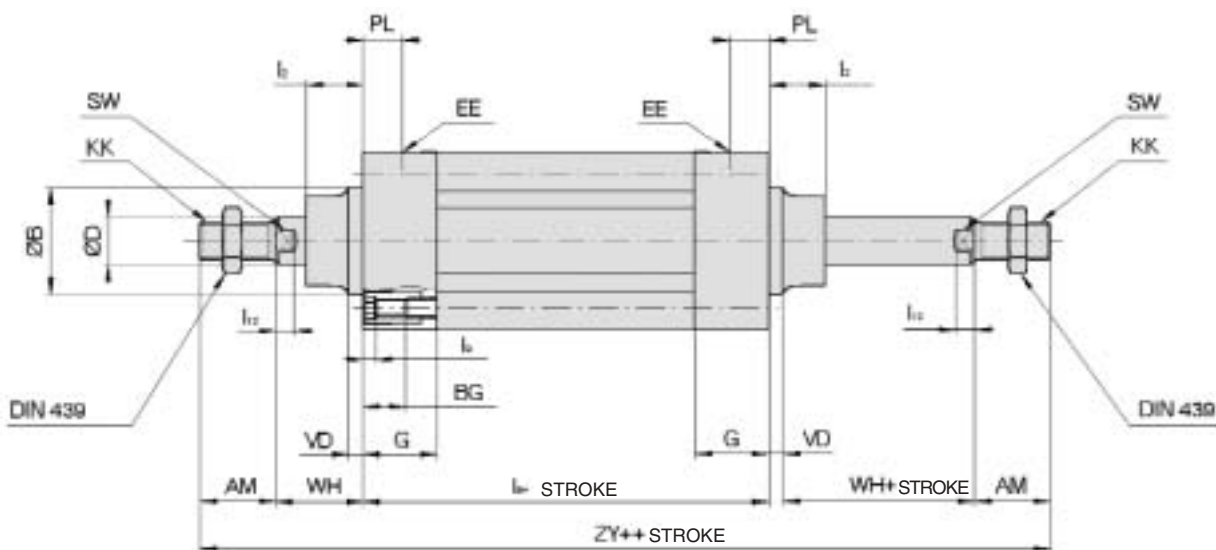

∅ Bore	AM	∅B	∅D	EE	PL	RT	$l_{12}$	KK	SW	G	BG	$l_8$	VD	VA	WA	WB	WH	ZZ	ZY	□E	□R	$l_2$	$l_9$
32	22	30	12	G1/8	13	M6	6	M10x1.25	10	27	16	94	4	4	4	6.5	26	146	190	46	32.5	15	4
40	24	35	16	G1/4	14	M6	6.5	M12x1.25	13	27	16	105	4	4	4	9	30	163	213	52	38	17	4
50	32	40	20	G1/4	15.5	M8	8	M16x1.5	16	31.5	16	106	6	4	5	10.5	37	179	244	65	46.5	24	5
63	32	45	20	G3/8	16.5	M8	8	M16x1.5	16	31.5	16	121	6	4	9	12	37	194	259	75	56.5	24	5
80	40	45	25	G3/8	19	M10	10	M20x1.5	21	38	16	128	8	4	11.5	14	46	218	300	95	72	30	5
100	40	55	30	G1/2	19	M10	10	M20x1.5	21	38	16	138	8	4	17	15	51	233	320	114	89	32	5

# Series CP95

## Dimensions – mounting accessories L, F, C and D

[mm]

### Mounting type L

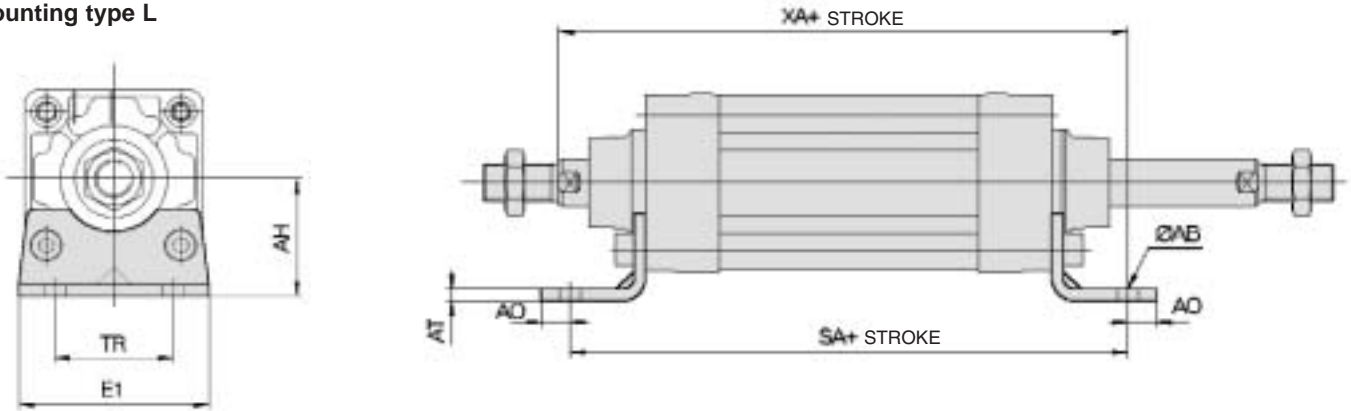

### Mounting type F

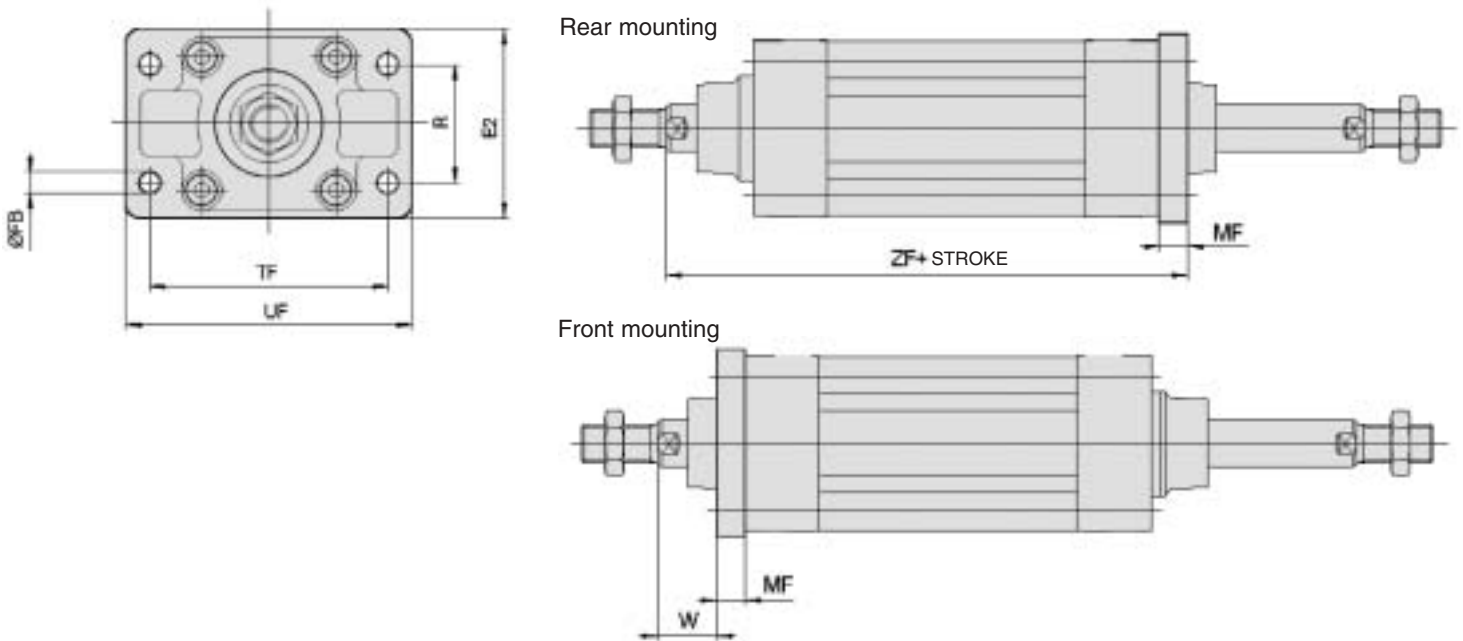

### Mounting type C

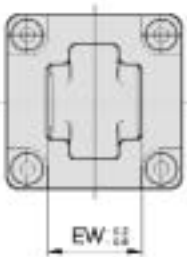

### Mounting type D

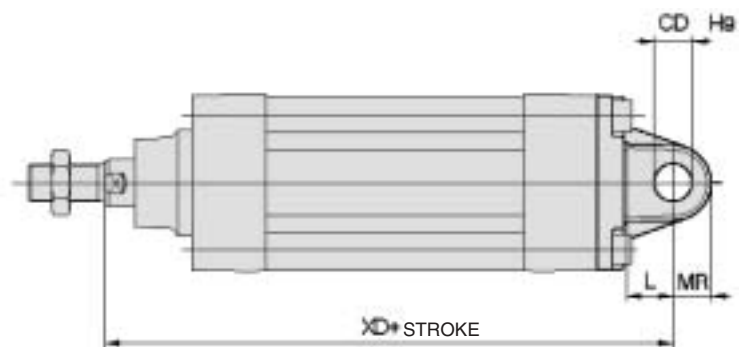
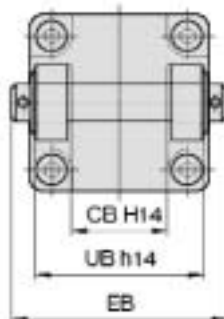

	E1	R	W	MF	ZF	ØFB	CD	EB	L	XD	UB	CB	EW	MR	TR	AO	AT	XA	SA	AH	ØAB	TF	LF	E2
32	48	32	18	10	130	7	10	65	12	142	45	26	26	9.5	32	10	4	144	142	32	7	64	79	50
40	55	36	20	10	145	9	12	75	15	160	52	28	28	12	36	11	4	163	161	36	9	72	90	55
50	68	45	25	12	155	9	12	80	15	170	60	32	32	12	45	12	5	175	170	45	9	90	110	70
63	80	50	25	12	170	9	16	90	20	190	70	40	40	16	50	12	5	190	185	50	9	100	120	80
80	100	63	30	16	190	12	16	110	20	210	80	50	50	16	63	14	6	215	210	63	12	126	153	100
100	120	75	35	16	205	14	20	140	25	230	110	60	60	20	75	16	6	230	220	71	14	150	178	120

## Accessories

### Rear single clevis C

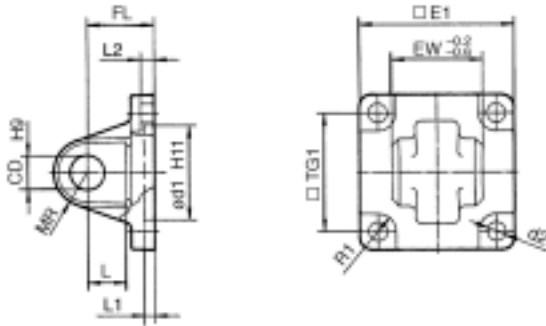

### Rear double clevis D

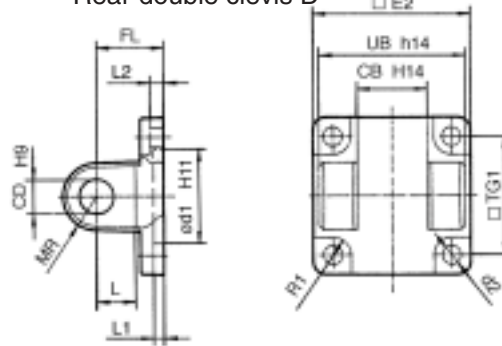

Bore (mm)	E1	EW	TG1	FL	L1	L	L2	ød1	CD	MR	d2	R1	E2	UB	CB
32	45	26	32.5	22	5	12	5.5	30	10	9.5	6.6	6.5	48	45	26
40	51	28	38	25	5	15	5.5	35	12	12	6.6	6.5	56	52	28
50	64	32	46.5	27	5	15	6.5	40	12	12	9	8.5	64	60	32
63	74	40	56.5	32	5	20	6.5	45	16	16	9	8.5	75	70	40
80	94	50	72	36	5	20	10	45	16	16	11	11	95	90	50
100	113	60	89	41	5	25	10	55	20	20	11	12	115	110	60

### Rear Single Clevis DS

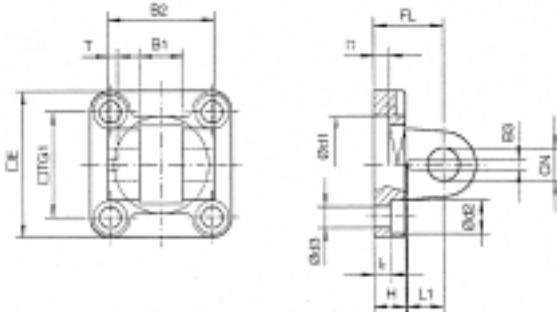

Bore (mm)	E	B1	B2	B3	TG1	T	L1	L3	I1	I2	FL	H	Ød1	Ød2	Ød3	CN	XD
32	45	14	34	3.3	32.5	3	11.5	41	5	5.5	22	10	30	10.5	6.6	10	142
40	55	16	40	4.3	38	4	12	48	5	5.5	25	10	35	11	6.6	12	160
50	65	21	45	4.3	46.5	4	14	54	5	6.5	27	10	40	15	9	16	170
63	75	21	51	4.3	56.5	4	14	60	5	6.5	32	12	45	15	9	16	190
80	95	25	65	4.3	72	4	16	75	5	10	36	16	45	18	11	20	210
100	115	25	75	6.3	89	4	16	85	5	10	41	16	55	18	11	20	230

### Rear Single Clevis CS

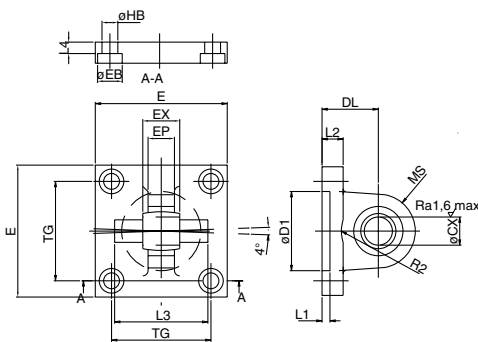

Part No.	Bore (mm)	E	TG	EX	DL	L1	L2	MS	L3	EB	HB	R2	CX	D1	L4	EP
CS5032	32	48	32.5	14	22	5	10	16	36	11	6.6	12.5	10	30	5.5	10
CS5040	40	56	38	16	25	5	10	16	42	11	6.6	14.5	12	35	5.5	11.5
CS5050	50	64	46.5	21	27	5	10	20	48	15	9	19.5	16	40	6.5	14.5
CS5063	63	75	56.5	21	32	5	12	22	55	15	9	19.5	16	45	6.5	14.5
CS5080	80	95	72	25	36	5	14	26	70	18	11	24.5	20	45	10	17.5
CS5100	100	115	89	25	41	5	16	26	80	18	11	24.5	20	55	10	17.5

### Counter pivot E

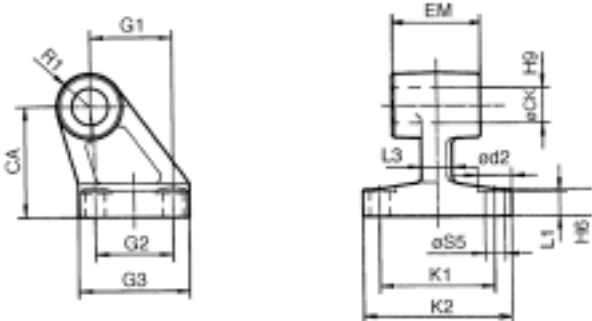

Bore (mm)	ød2	øCK	øS5	K1	K2	L3	G1	L1	G2	EM	G3	CA	H6	R1
32	11	10	6.6	38	51	10	21	7	18	26	31	32	8	10
40	11	12	6.6	41	54	10	24	9	22	28	35	36	10	11
50	15	12	9	50	65	12	33	11	30	32	45	45	12	12
63	15	16	9	52	67	14	37	11	35	40	50	50	12	15
80	18	16	11	66	86	18	47	12.5	40	50	60	63	14	15
100	18	20	11	76	96	20	55	13.5	50	60	70	71	15	19

### Angles rear clevis ES

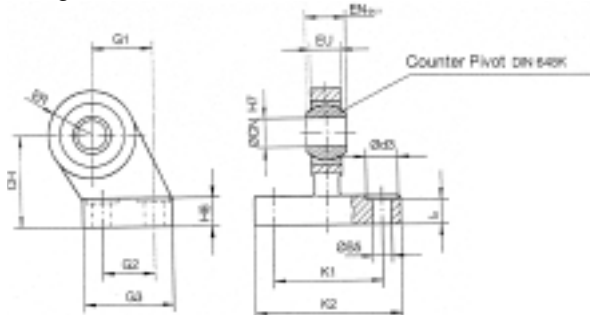

Bore (mm)	ød3	øCN	øS5	K1	K2	I2	G1	G2	G3	EN	EU	CH	H6	ER
32	11	10	6.6	38	51	8.5	21	18	31	14	10.5	32	10	15
40	11	12	6.6	41	54	8.5	24	22	35	16	12	36	10	18
50	15	16	9	50	65	10.5	33	30	45	21	15	45	12	20
63	15	16	9	52	67	10.5	37	35	50	21	15	50	12	23
80	18	20	11	66	86	11.5	47	40	60	25	18	63	14	27
100	18	20	11	76	96	12.5	55	50	70	25	18	71	15	30

# Series CP95

## Accessories

### Floating joint JA

Steel, zinc chromate plated

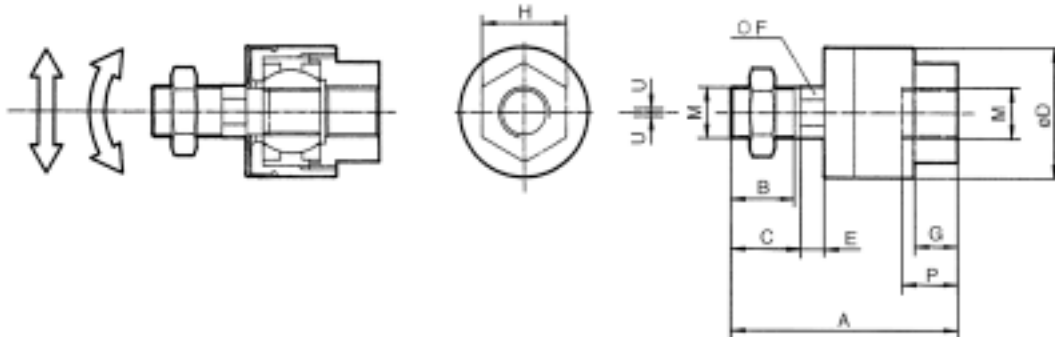

Bore (mm)	M	A	B	C	øD	E	F	G	H	P	U	Load (kn)	Weight (g)	Radial deflection
32	M10 X 1.25	49.5	19.5	—	24	5	8	8	17	9	0.5	2.5	70	±5
40	M12 X 1.25	60	20	—	31	6	11	11	22	13	0.75	4.4	160	
50/63	M16 X 1.5	71.5	22	—	41	7.5	14	13.5	27	15	1.0	11	300	
80/100	M20 X 1.5	101	28	31	59.5	11.5	24	16	32	18	2.0	18	1080	

### Piston rod clevis GKM (ISO 8140)

Steel, zinc chromate plated

Bore (mm)	e	b	d	øf	L1	c	a
32	M10 X 1.25	10	40	10	52	20	20
40	M12 X 1.25	12	48	12	62	24	24
50/63	M16 X 1.5	16	64	16	83	32	32
80/100	M20 X 1.5	20	80	20	105	40	40

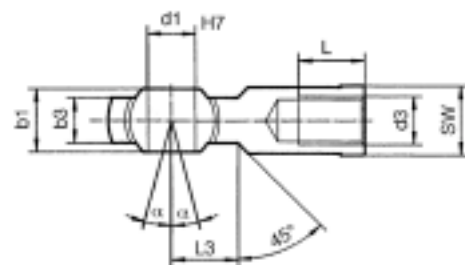
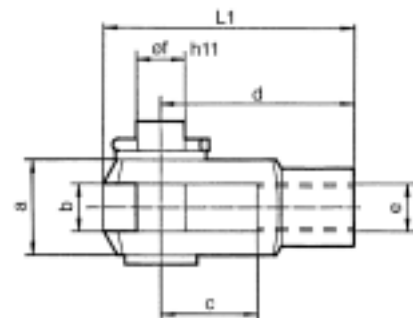

### Piston rod ball joint KJ (ISO 8139)

Steel, zinc chromate plated

Bore (mm)	d3	d1	h	d6	b3	b1	L	d7	α	L3	SW
32	M10 X 1.25	10	43	28	10.5	14	20	19	13°	14	17
40	M12 X 1.25	12	50	32	12	16	22	22	13°	16	19
50/63	M16 X 1.5	16	64	42	15	21	28	27	15°	26	32
80/100	M20 X 1.5	20	77	50	18	25	33	34	15°	26	32

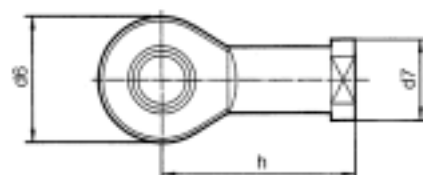

# ISO Cylinder: Double Acting Series CP95K

ø32, ø40, ø50, ø63, ø80, ø100

## How to Order

**Standard** CP95KD **B** **32** **100** **W** **Z76** **S**

**Built-in magnet**

**Mounting**

<b>B</b>	Basic/without bracket
<b>L</b>	Axial foot
<b>F</b>	Front flange
<b>G</b>	Rear flange
<b>C</b>	Single rear clevis
<b>D</b>	Double rear clevis

**Bore size**

<b>32</b>	32mm
<b>40</b>	40mm
<b>50</b>	50mm
<b>63</b>	63mm
<b>80</b>	80mm
<b>100</b>	100mm

**Auto switch**

—	Without auto switch
<b>S</b>	1
<b>3</b>	3
<b>n</b>	n

\* Refer to table below for selection of applicable auto switch.

**Number of auto switches**

—	2
<b>S</b>	1
<b>3</b>	3
<b>n</b>	n

**Stroke (mm)**

Refer to standard stroke table on p.5-12 maximum 1000mm

**Rod specifications**

—	Stainless steel 1.4301 standard
<b>W</b>	double/through rod

### Applicable Auto Switches/Direct mounting type

Type	Special function	Electrical entry	Indicator light	Wiring (output)	Load voltage		Auto switch model		Lead wire length (m) <sup>(Note)</sup>			Applicable load	Mounting bracket	
					DC	AC	Electrical entry direction		0.5 (Nil)	3 (L)	5 (Z)			
							Vertical	Lateral						
Reed switch	—	Grommet	Yes	3 wire	—	5V	—	Z76	●	●	—	IC circuit	—	
				2 wire	24V	—	100V	—	Z73	●	●	●	—	Relay PLC
Solid state switch	Diagnostic indication (2 colour indicator) Water resistant (2 colour indicator)	Grommet	Yes	3 wire (NPN)	24V	5V, 12V	—	Y69A	Y59A	●	●	○	IC circuit	BMP1-032
				3 wire (PNP)		12V		Y7PV	Y7P	●	●	○	—	
				2 wire				Y69B	Y59B	●	●	○	—	
				3 wire (NPN)		5V, 12V		Y7NWW	Y7NW	●	●	○	IC circuit	
				3 wire (PNP)				Y7PWW	Y7PW	●	●	○	—	
				2 wire		12V		Y7BWW	Y7BW	●	●	○	—	
—	Connector and Grommet	Yes	3 wire (NPN)	24V	5V, 12V	—	M9NV	M9N	●	●	○	IC circuit	Relay PLC	BMP1-032 + BMG2-012
3 wire (PNP)	M9PV		M9P				●	●	○					
2 wire	M9BV		M9B				●	●	○					

Lead wire length 0.5m..... — (Example: A53)  
 3m..... L (Example: A53L)  
 5m..... Z (Example: A53Z)

○: Manufactured upon receipt of order.

### Auto Switch Mounting Accessories for D-M9

Bore size (mm)	Order No.
ø32~ø100	<b>BMP1-032</b>
	<b>BMG2-012</b>

Note: For the mounting of auto switch D-M9, both BMP1-032 and BMG2-012 are necessary.

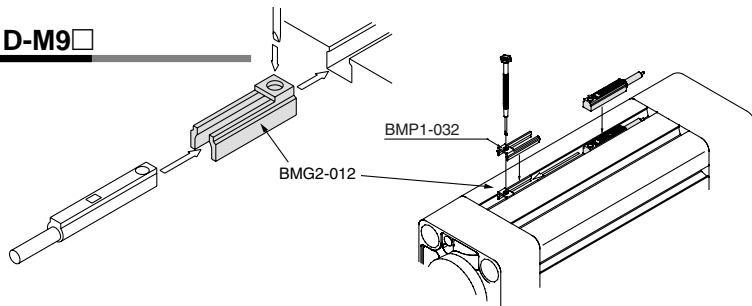

# Series CP95K



ISO Symbol  
Double acting

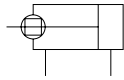

## Minimum Strokes for Auto Switch Mounting

Refer to p.5-32 on "Minimum Strokes for Auto Switch Mounting".

## Theoretical Force

OUT side is identical to double acting single rod.  
Refer to table below for IN side.

Bore size (mm)	Rod diameter (mm <sup>2</sup> )	Bore size (mm)	Rod diameter (mm <sup>2</sup> )
32	675	63	2804
40	1082	80	4568
50	1651	100	7223

Theoretical force (N) =  
Pressure (MPa) X Piston area (mm<sup>2</sup>)

## Specifications

Bore size	ø32	ø40	ø50	ø63	ø80	ø100
Action	Double acting					
Fluid	Air					
Proof pressure	1.5MPa					
Max. operating pressure	1.0MPa					
Min. operating pressure	0.05MPa					
Ambient and fluid temperature	Without magnet -10 to 70°C (No freezing)					
	With magnet -10 to 60°C (No freezing)					
Lubrication	Not required (Non-lube)					
Operating piston speed	50 to 1000mm/s					
Allowable stroke tolerance	to 250: <sup>+1.0</sup> <sub>0</sub> , 251 to 1000: <sup>+1.4</sup> <sub>0</sub>					
Cushion	Both ends (Air cushion) <sup>(1)</sup>					
Port size	G1/8	G1/4	G1/4	G3/8	G3/8	G1/2
Mounting	Basic, axial direction foot, front flange, rear flange, single rear clevis, double rear clevis, spherical bearing					
Non-rotating accuracy	ø32, ø40	±0.5°				
	ø50, ø63	±0.5°				
	ø80, ø100	±0.3°				
Allowable rotating torque (Nm) max.	ø32	0.25	ø80		0.79	
	ø40	0.45	ø100		0.93	
	ø50, ø63	0.64	—		—	

Note 1) Absorbable kinetic energy by cushion mechanism is identical to double acting single rod.

## Standard Stroke

Bore size (mm)	Standard stroke (mm)	Max. * stroke
32	25, 50, 80, 100, 125, 160, 200, 250, 320, 400, 500	700
40	25, 50, 80, 100, 125, 160, 200, 250, 320, 400, 500	800
50	25, 50, 80, 100, 125, 160, 200, 250, 320, 400, 500, 600	1000
63	25, 50, 80, 100, 125, 160, 200, 250, 320, 400, 500, 600	1000
80	25, 50, 80, 100, 125, 160, 200, 250, 320, 400, 500, 600	1000
100	25, 50, 80, 100, 125, 160, 200, 250, 320, 400, 500, 600	1000

Intermediate strokes are available.

\*Please consult SMC for longer stroke.

## Weight

Bore size (mm)		32	40	50	63	80	100
Basic weight	Basic	0.56	0.84	1.39	1.91	3.22	4.24
	Axial foot	0.16	0.20	0.38	0.46	0.89	1.09
	Flange	0.20	0.23	0.47	0.58	1.30	1.81
	Single clevis	0.16	0.23	0.37	0.60	1.07	1.73
	Double clevis	0.20	0.32	0.45	0.71	1.28	2.11
Additional weight per 50 stroke		0.11	0.16	0.26	0.27	0.42	0.56
Accessories	Single rod clevis	0.15	0.23	0.26	0.26	0.60	0.83
	Double rod clevis (with pin)	0.22	0.37	0.43	0.43	0.87	1.27

Calculation example: CP95KD40-100

- Basic weight ..... 0.84 (Basic)
  - Additional weight ... 0.16/50 stroke
  - Cylinder stroke ..... 100 stroke
  - Mounting ..... 0.32 (Double clevis)
- 0.84+0.16 X 100/50+0.32=1.48kg

## Part No: Mounting Bracket, Mounting Accessories

Description	Bore size	ø32	ø40	ø50	ø63	ø80	ø100
L	Foot <sup>(1)</sup>	L5032	L5040	L5050	L5063	L5080	L5100
F,G	Flange	F5032	F5040	F5050	F5063	F5080	F5100
C	Single rear clevis	C5032	C5040	C5050	C5063	C5080	C5100
D	Double rear clevis	D5032	D5040	D5050	D5063	D5080	D5100
DS	Double rear clevis (for ES accessory)	DS5032	DS5040	DS5050	DS5063	DS5080	DS5100
ES	Angled rear clevis with ball joint	ES5032	ES5040	ES5050	ES5063	ES5080	ES5100
E	Angled rear clevis	E5032	E5040	E5050	E5063	E5080	E5100
GKM	Rod clevis	GKM10-20	GKM12-24	GKM16-32	GKM16-32	GKM20-40	GKM20-40
KJ	Piston rod ball joint	KJ10D	KJ12D	KJ16D	KJ16D	KJ20D	KJ20D
JA	Floating joint	JA30-10-125	JA40-12-125	JA50-16-150	JA50-16-150	JA80-20-150	JA150-20-150

Note 1) Two foot brackets required for one cylinder.

Note 2) Accessories for each mounting bracket are as follows.

Foot, Flange, Single clevis: Mounting bolts  
Double rear clevis: (D, DS): Clevis pin

Note 3) GKM according to ISO 8140

Note 4) KJ according to ISO 8139

Note 5) Piston rod nut is standard

## Construction

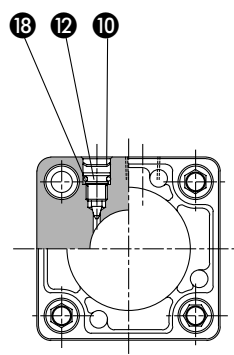
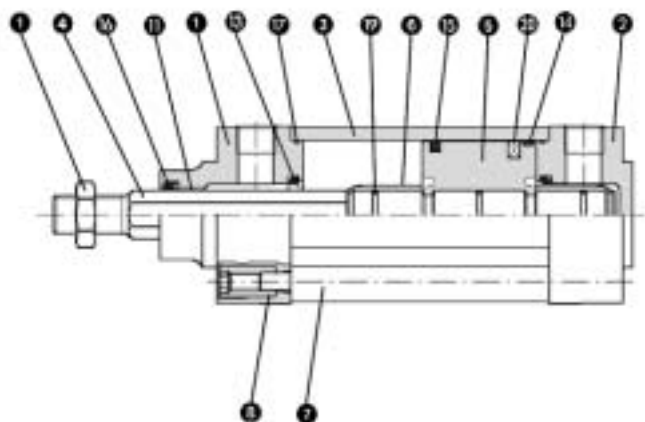

### Parts list

No.	Description	Material
1	Head cover	Die-cast aluminum
2	End cover	Die-cast aluminum
3	Cylinder tube	Die-cast aluminum
4	Piston rod	Stainless Steel
5	Piston	Die-cast aluminum
6	Cushion ring	Brass
7	Tie rod	Steel, zinc chromate plated
8	Tie rod nut	Steel, zinc chromate plated
9	Rod end nut	Steel, zinc chromate plated
10	Snap ring	Steel nickel plated
11	Bushing	Lead-bronze casting
12	Cushion valve	Steel, zinc chromate plated
13	Cushion seal	Elastomer
14	Wear ring	Antifriction material
15	Piston seal	NBR
16	Rod seal	NBR
17	Cylinder tube gasket	NBR
18	Cushioning valve seal	NBR
19	Piston/rod gasket	NBR
20	Magnet ring	

### Replacement parts: Seal kits

Ø32 includes the order No. from 13 to 17,  
 Ø40-Ø100 includes from 12 to 18.

Ø Bore	Order No.
32	<b>CK95-32</b>
40	<b>CK95-40</b>
50	<b>CK95-50</b>
63	<b>CK95-63</b>
80	<b>CK95-80</b>
100	<b>CK95-100</b>

# Series CP95K

## Dimensions – non-rotating rod specification

[mm]

### CP95K□BØ-Stroke

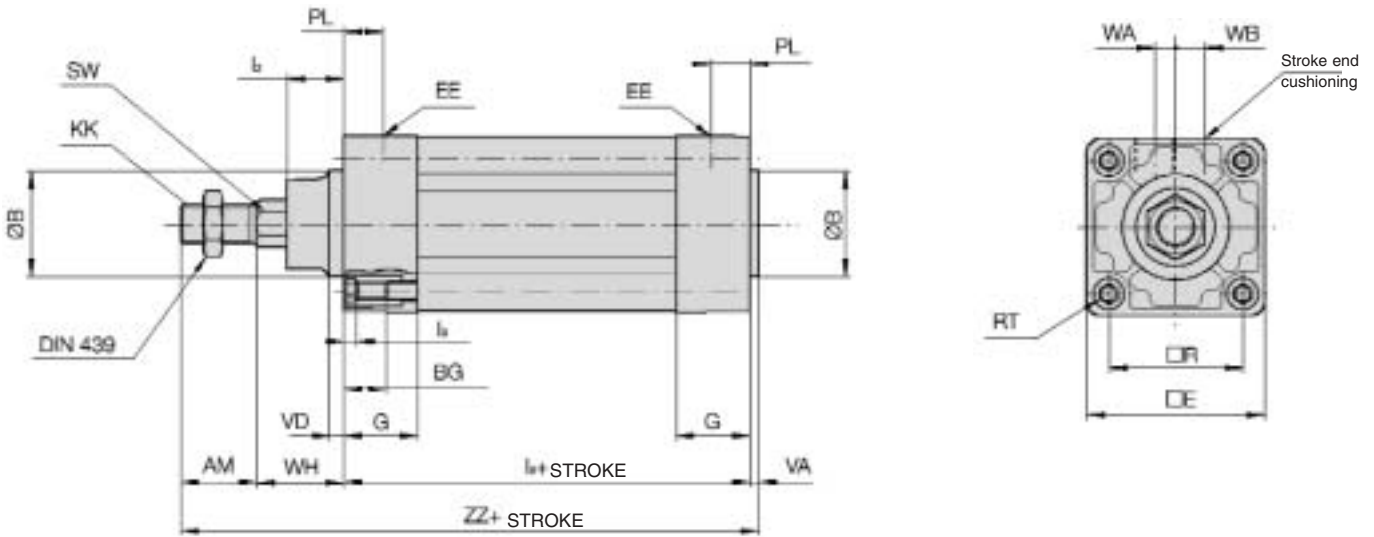

### CP95K□BØ-Stroke W

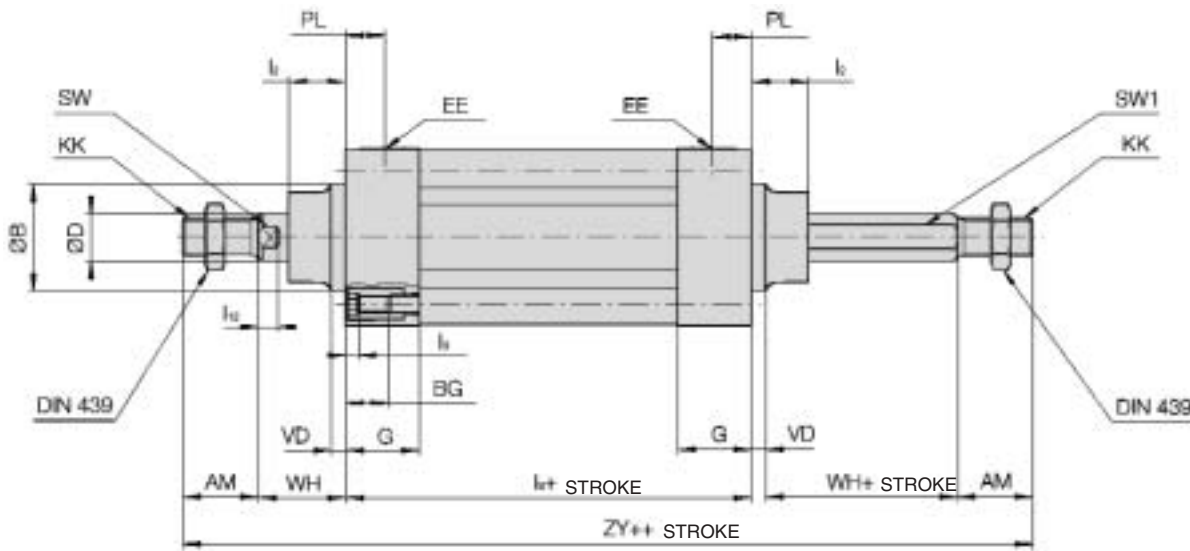

$\varnothing$ Bore	AM	$\varnothing B$	$\varnothing D$	EE	PL	RT	$l_{12}$	KK	SW	SW1	G	BG	$l_8$	VD	VA	WA	WB	WH	ZZ	ZY	$\varnothing E$	$\varnothing R$	$l_2$	$l_g$
32	22	30	12	G1/8	13	M6	6	M10x1.25	10	12.2	27	16	94	4	4	4	6.5	26	146	190	46	32.5	15	4
40	24	35	16	G1/4	14	M6	6.5	M12x1.25	13	14.2	27	16	105	4	4	4	9	30	163	213	52	38	17	4
50	32	40	20	G1/4	15.5	M8	8	M16x1.5	16	19	31.5	16	106	6	4	5	10.5	37	179	244	65	46.5	24	5
63	32	45	20	G3/8	16.5	M8	8	M16x1.5	16	19	31.5	16	121	6	4	9	12	37	194	259	75	56.5	24	5
80	40	45	25	G3/8	19	M10	10	M20x1.5	21	23	38	16	128	8	4	11.5	14	46	218	300	95	72	30	5
100	40	55	30	G1/2	19	M10	10	M20x1.5	21	27	38	16	138	8	4	17	15	51	233	320	114	89	32	5

# ISO Cylinder/Standard: Low Friction Series CP95Q

ø32, ø40, ø50, ø63, ø80, ø100

## How to Order

**Standard** CP95QD B 32 100 R CA Z76 S

**Built-in magnet**

**Mounting**

B	Basic/without bracket
L	Axial foot
F	Front flange
G	Rear flange
C	Single rear clevis
D	Double rear clevis

**Bore size**

32	32mm
40	40mm
50	50mm
63	63mm
80	80mm
100	100mm

**Auto switch**

—	Without auto switch
---	---------------------

\* Refer to table below for selection of applicable auto switch.

**Number of auto switches**

—	2
S	1
3	3
n	n

**Direction of low friction**

CA	With pressure at head side
CB	With pressure at rod side

**Rod specifications**

—	Hard chrome as standard
R	Stainless steel piston rod
K	Stainless steel and acid-proof piston rod

**Stroke (mm)**  
Refer to standard stroke table on p.5-16 maximum 1000mm

### Applicable Auto Switches/Direct mounting type

Type	Special function	Electrical entry	Indicator light	Wiring (output)	Load voltage		Auto switch model		Lead wire length (m) <sup>Note)</sup>			Applicable load		Mounting bracket		
					DC	AC	Electrical entry direction		0.5 (Nil)	3 (L)	5 (Z)	IC circuit	Relay PLC			
Reed switch	—	Grommet	Yes	3 wire	—	5V	—	Vertical	Z76	●	●			—	IC circuit	—
				2 wire	24V	—	100V	—	Z73	●	●	●	—	Relay PLC		
Solid state switch	—	Grommet	Yes	3 wire (NPN)	24V	5V, 12V	—	Vertical	Y69A	Y59A	●	●	○	IC circuit	Relay PLC	
				3 wire (PNP)				Y7PV	Y7P	●	●	○	—			
				2 wire				Y69B	Y59B	●	●	○	—			
				3 wire (NPN)				Y7NWV	Y7NW	●	●	○	IC circuit			
				3 wire (PNP)				Y7PWV	Y7PW	●	●	○	—			
				2 wire				Y7BWV	Y7BW	●	●	○	—			
Water resistant (2 colour indicator)	—	Connector and Grommet	Yes	3 wire (NPN)	24V	5V, 12V	—	Vertical	M9NV	M9N	●	●	○	IC circuit	Relay PLC	
				3 wire (PNP)				M9PV	M9P	●	●	○	—			
—	—	—	—	2 wire	—	12V	—	Vertical	M9BV	M9B	●	●	○	—	BMP1-032 + BMG2-012	

\* Lead wire length 0.5m..... — (Example: A53)  
3m..... L (Example: A53L)  
5m..... Z (Example: A53Z)

○: Manufactured upon receipt of order.

### Auto Switch Mounting Accessories for D-M9

Bore size (mm)	Order No.
ø32~ø100	BMP1-032
	BMG2-012

Note: For the mounting of auto switch D-M9, both BMP1-032 and BMG2-012 are necessary.

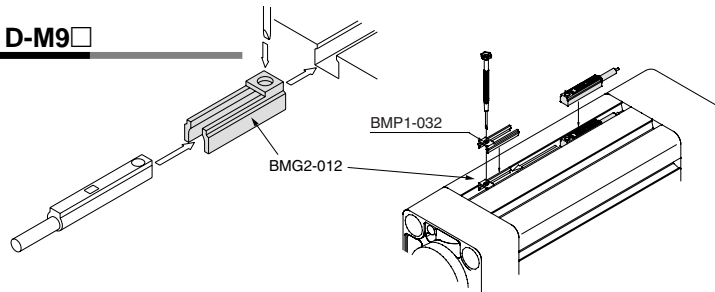

## Specifications



Bore size (mm)	32	40	50	63	80	100
Action	Double acting single rod					
Direction of low friction	One direction					
Fluid	Air					
Proof pressure	1.05MPa					
Max. operating pressure	0.7MPa					
Min. operating pressure	0.01MPa					
Ambient and fluid temperature	Without auto switch: -10 to 70°C (No freezing)					
	With auto switch: -10 to 60°C (No freezing)					
Lubrication	Not required (Non-lube)					
Cushion	None					
Port size	G 1/8	G 1/4	G 1/4	G 3/8	G 3/8	G 1/2
Mounting	Basic, Foot, Front flange, Rear flange, Single clevis, Double clevis, spherical bearing					

## Standard Stroke

ISO Symbol  
Double acting

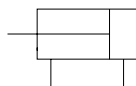

Bore size (mm)	Standard stroke (mm)	Max. * stroke
32	25, 50, 80, 100, 125, 160, 200, 250, 320, 400, 500	700
40	25, 50, 80, 100, 125, 160, 200, 250, 320, 400, 500	800
50	25, 50, 80, 100, 125, 160, 200, 250, 320, 400, 500, 600	1000
63	25, 50, 80, 100, 125, 160, 200, 250, 320, 400, 500, 600	1000
80	25, 50, 80, 100, 125, 160, 200, 250, 320, 400, 500, 600	1000
100	25, 50, 80, 100, 125, 160, 200, 250, 320, 400, 500, 600	1000

Intermediate strokes are available.

\* Please consult with SMC for longer stroke.

## Part No: Mounting Bracket, Mounting Accessories

Description	Bore size	ø32	ø40	ø50	ø63	ø80	ø100
L	Foot <sup>(1)</sup>	L5032	L5040	L5050	L5063	L5080	L5100
F,G	Flange	F5032	F5040	F5050	F5063	F5080	F5100
C	Single rear clevis	C5032	C5040	C5050	C5063	C5080	C5100
D	Double rear clevis	D5032	D5040	D5050	D5063	D5080	D5100
DS	Double rear clevis (for ES accessory)	DS5032	DS5040	DS5050	DS5063	DS5080	DS5100
ES	Angled rear clevis with ball joint	ES5032	ES5040	ES5050	ES5063	ES5080	ES5100
E	Angled rear clevis	E5032	E5040	E5050	E5063	E5080	E5100
GKM	Rod clevis	GKM10-20	GKM12-24	GKM16-32	GKM18-32	GKM20-40	GKM20-40
KJ	Piston rod ball joint	KJ10D	KJ12D	KJ16D	KJ16D	KJ20D	KJ20D
JA	Floating joint	JA30-10-125	JA40-12-125	JA50-16-150	JA50-16-150	JA80-20-150	JA80-20-150

Note 1) Two foot brackets required for one cylinder.

Note 2) Accessories for each mounting bracket are as follows.

Foot, Flange, Single clevis: Mounting bolts

Double rear clevis: (D,DS): Clevis pin

Note 3) GKM according to ISO 8140

Note 4) KJ according to ISO 8139

Note 5) Piston rod nut is standard

## Selection Guide for the Low Friction Side

- ① When used as a balancer etc., follow the example of the application mentioned earlier applying pressure at one port while leaving the other port open to atmosphere.
  - With pressure at rod cover port  
..... Low friction side CB (Example of application ①)
  - With pressure at head cover port  
..... Low friction side CA (Example of application ②)

In both cases, as long as the outside pressure moves the piston rod, low friction can result in the direction of extension and retraction.
- ② When used applying pressure to both ports the same time, follow the above mentioned guide and as in the following.
  - With relatively higher pressure on rod cover port  
..... Use Low friction side CB
  - With relatively higher pressure on head cover port  
..... Use Low friction side CA

## Application Example

Low friction cylinder used in combination with precision regulator (Series IR)

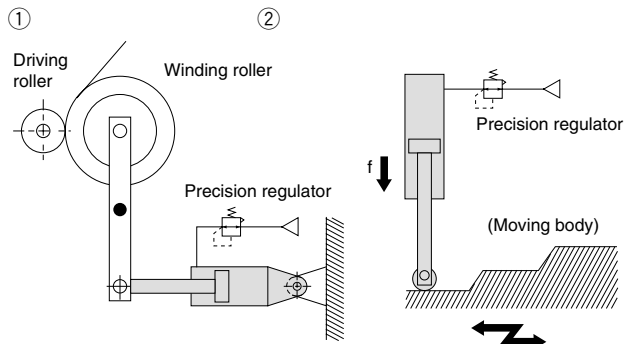

**For Dimensions, Weight, Accessories see CP95S**

# Series CP95Q

## Construction

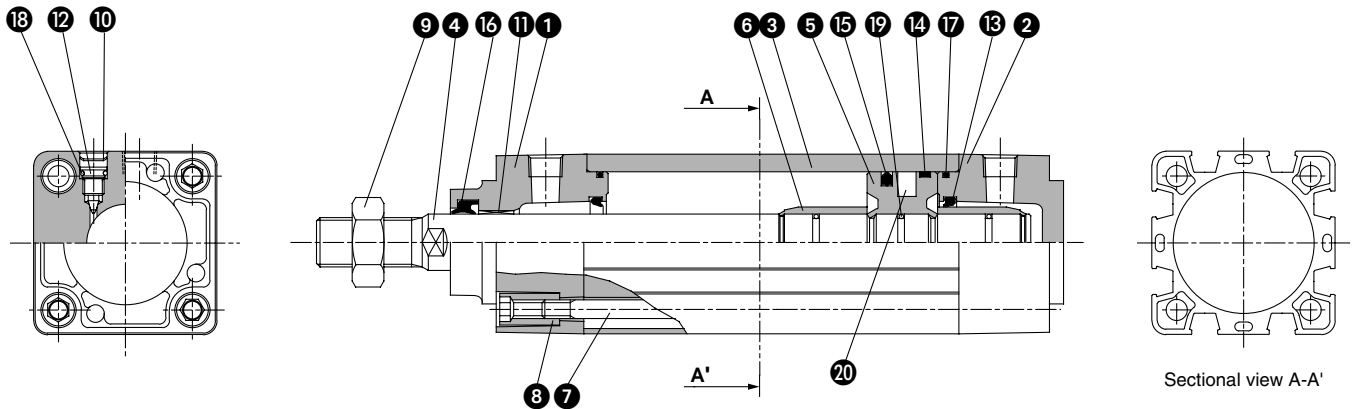

### Parts list

No.	Description	Material
①	Head cover	Die-cast aluminum
②	End cover	Die-cast aluminum
③	Cylinder tube	Die-cast aluminum
④	Piston rod	Hard chromed steel C45
⑤	Piston	Die-cast aluminum
⑥	Cushion ring	Brass
⑦	Tie rod	Steel, zinc chromate plated
⑧	Tie rod nut	Steel, zinc chromate plated
⑨	Rod end nut	Steel, zinc chromate plated
⑩	Snap ring	Steel nickel plated
⑪	Bushing	Lead-bronze casting
⑫	Cushion valve	Steel, zinc chromate plated
⑬	Cushion seal	Elastomer
⑭	Wear ring	Antifriction material
⑮	Piston seal	NBR
⑯	Rod seal	NBR
⑰	Cylinder tube gasket	NBR
⑱	Cushioning valve seal	NBR
⑲	Piston/rod gasket	NBR
⑳	Magnet ring	

### Replacement parts: Seal kits

Ø32 includes order No. from ⑬ to ⑰,  
 Ø40 - Ø100 includes from ⑫ to ⑬

Ø	Order No.
32	CQ95-32
40	CQ95-40
50	CQ95-50
63	CQ95-63
80	CQ95-80
100	CQ95-100

# ISO Cylinder: Double Acting with Positioner

# Series CP95P

ø32, ø40, ø50, ø63, ø80, ø100

## How to Order

**Standard** CP95PD B 32 100 Z76 S

**Built-in magnet** (points to B)

**Mounting** (points to B)

**Bore size** (points to 32)

**Stroke (mm)** (points to 100)

**Auto switch** (points to Z76)

**Number of auto switches** (points to S)

B	Basic/without bracket
L	Axial foot
G	Rear flange
C	Single rear clevis
D	Double rear clevis

50	50mm
63	63mm
80	80mm
100	100mm

—	Without auto switch
S	1
3	3
n	n

\* Refer to table below for selection of applicable auto switch.

### Applicable Auto Switches/Direct mounting type

Refer to standard stroke table on p.5-4 maximum 300mm

Type	Special function	Electrical entry	Indicator light	Wiring (output)	Load voltage		Auto switch model		Lead wire length (m) <sup>(Note)</sup>			Applicable load		Mounting bracket
					DC	AC	Electrical entry direction		0.5 (Nil)	3 (L)	5 (Z)	IC circuit	Relay PLC	
Reed switch	—	Grommet	Yes	3 wire	24V	—	5V	—	Z76	●	●			—
				2 wire		—	100V	—	Z73	●	●	●	—	
				—		5V, 12V	100V or less	—	Z80	●	●	—	—	
Solid state switch	Diagnostic indication (2 colour indicator)	Grommet	Yes	3 wire (NPN)	24V	5V, 12V	—	Y69A	Y59A	●	●	○	—	BMP1-032
				3 wire (PNP)				Y7PV	Y7P	●	●	○	—	
				2 wire				Y69B	Y59B	●	●	○	—	
				3 wire (NPN)				Y7NWV	Y7NW	●	●	○	—	
				3 wire (PNP)				Y7PWV	Y7PW	●	●	○	—	
				2 wire				Y7BWV	Y7BW	●	●	○	—	
	Water resistant (2 colour indicator)	—	Y7BA	—	●	●	○	—						
—	Connector and Grommet	Yes	3 wire (NPN)	24V	5V, 12V	—	M9NV	M9N	●	●	○	IC circuit	Relay PLC	BMP1-032 + BMG2-012
			3 wire (PNP)				M9PV	M9P	●	●	○			
			2 wire				M9BV	M9B	●	●	○			

\* Lead wire length 0.5m..... — (Example: A53)  
 3m..... L (Example: A53L)  
 5m..... Z (Example: A53Z)

○: Manufactured upon receipt of order.

### Auto Switch Mounting Accessories for D-M9□

Bore size (mm)	Order No.
ø32~ø100	<b>BMP1-032</b>
	<b>BMG2-012</b>

Note: For the mounting of auto switch D-M9, both BMP1-032 and BMG2-012 are necessary.

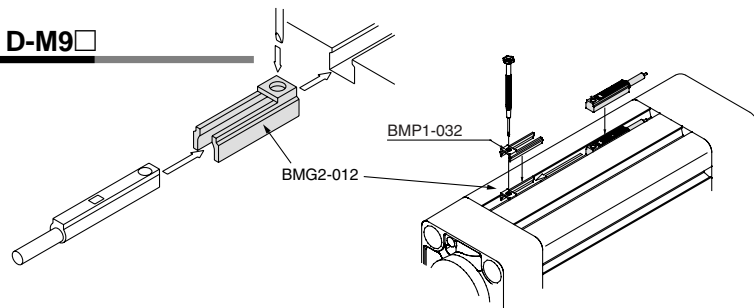

# Series CP95P

## Specifications

### Application:

The positioner IP200 is capable of pneumatic positioning of the piston. Adjustable positions can be reached with high repeating accuracy. The piston stroke is in proportion to the air pressure input signal (0.02-0.01MPa). External forces on the position of the piston are reduced to a minimum by a special control system and an integrated function to revert the set position.

The IP200 shows excellent performance in remote control or standard control of flaps, proportioning devices, pumps, gears usw.

### Specifications

- The bleed pressure acts directly onto the flapper plate. A change of the input signal will cause an instantaneous movement of the piston rod.
- easy and simple adjustment of neutral point and operation band from outside.
- Return spring is protected against accidental touches
- Positioner cylinder conforms to ISO and CETOP recommendations
- No change in dimensions with auto switch capability

## Specifications

Fluid	Air 5µm filtration
Supply pressure "SUP" (MPa)	0.3 ~ 0.7
Signal pressure "SIG" (MPa)	0.02 ~ 0.1
Fluid temperature (°C)	+5 to +60
Linearity	< 2%*
Hystereses	< 1%*
Repeatability	< 1%*
Sensitivity	< 1%*
Port size	G1/4
Gauge port	G1/8
Primary pressure	0.5% with 0.5MPa
Flow rate (l/min)	250 with 0.5MPa
Leakage	< 18 with 0.5MPa
Bore Size (mm)	40 to 100
Cylinder stroke (mm)	25 to 300
Standard stroke (mm)	50/100/150/200/250/300
Max. possible stroke (mm)	300

\*different in % related to full span.

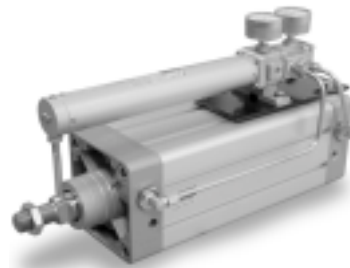

## Part No: Mounting Bracket, Mounting Accessories

Description	ø50	ø63	ø80	ø100
<b>L</b>	L5050	L5063	L5080	L5100
<b>G</b>	F5050	F5063	F5080	F5100
<b>C</b>	C5050	C5063	C5080	C5100
<b>D</b>	D5050	D5063	D5080	D5100
<b>DS</b>	DS5050	DS5063	DS5080	DS5100
<b>ES</b>	ES5050	ES5063	ES5080	ES5100
<b>E</b>	E5050	E5063	E5080	E5100
<b>GKM</b>	GKM16-32	GKM16-32	GKM20-40	GKM20-40
<b>KJ</b>	KJ16D	KJ16D	KJ20D	KJ20D
<b>JA</b>	JAS0-16-150	JAS0-16-150	JAH50-20-150	JAH50-20-150

Note 1) Two foot brackets required for one cylinder.

Note 2) Accessories for each mounting bracket are as follows.

Foot, Flange, Single clevis: Mounting bolts

Double rear clevis: (D,DS): Clevis pin

Note 3) GKM according to ISO 8140

Note 4) KJ according to ISO 8139

Note 5) Piston rod nut is standard

## Weight accessories (kg)

Ø	50	63	80	100
<b>L</b>	0.38	0.46	0.89	1.09
<b>F</b>	0.47	0.58	1.30	1.81
<b>C</b>	0.37	0.60	1.07	1.73
<b>D</b>	0.45	0.71	1.28	2.11
<b>E</b>	0.42	0.52	0.94	1.40

## Weight Table

Weight (kg)					
	Ø	50	63	80	100
	<b>B</b>		2.27	2.79	4.11
<b>Weight each 50mm stroke</b>		0.32	0.33	0.48	0.62

### Example: CP95PDB50-200

Cylinder Ø50mm, stroke 200mm

Bracket L

Weight = 2.72kg + (0.31kg ×  $\frac{200}{50}$ ) = 3.96kg

For dimensions of the brackets and accessories, please see C95S, page 5-4

## Dimensions

Signal Pressure/Stroke Diagram

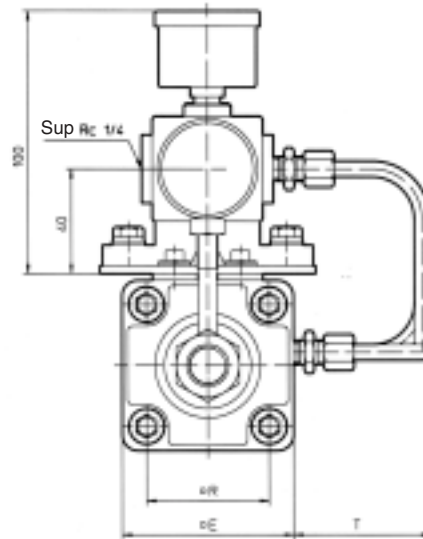
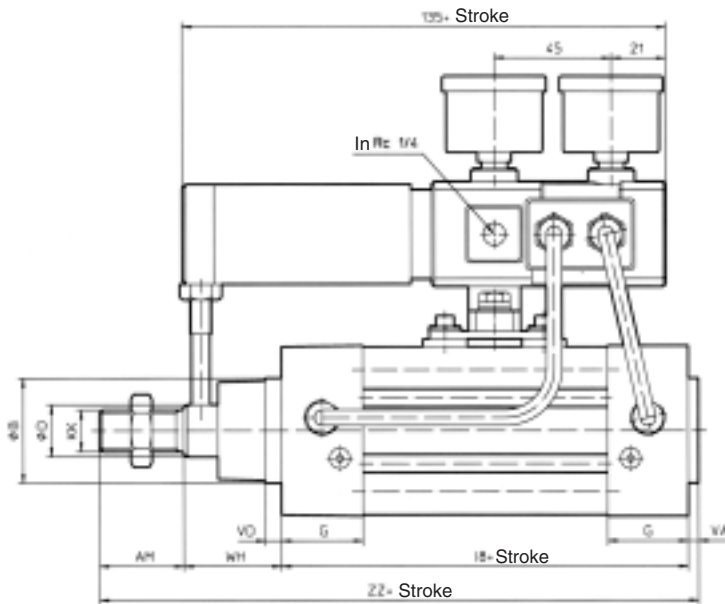
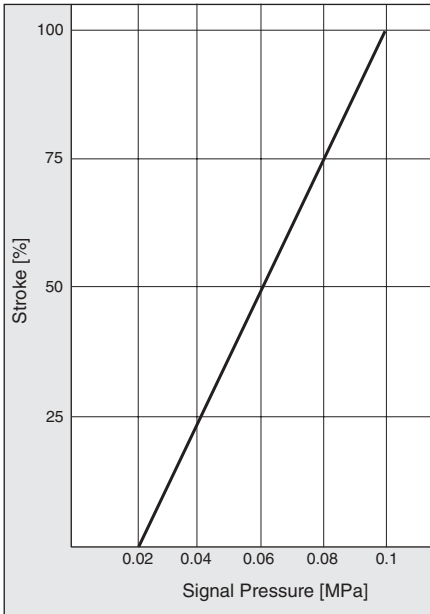

Ø	AM	ØB	ØD	±E	G	KK	I 8	±R	T	VA	VD	WH	ZZ
50	32	40	20	65	31.5	M16 x 1.5	106	46.5	52.1	4	6	37	179
63	32	45	20	75	31.5	M16 x 1.5	121	56.5	53.8	4	6	37	194
80	40	45	25	95	38	M20 x 1.5	128	72	53.8	4	8	46	218
100	40	55	30	114	38	M20 x 1.5	138	89	25.6	4	8	51	233

# ISO Cylinder/Standard: Double Acting with Lock

## Series CP95N

ø32, ø40, ø50, ø63, ø80, ø100

### How to Order

**Standard** CP95ND B 32 100 W Z76 S

**Built-in magnet**

**Mounting**

B	Basic/without bracket
L	Axial foot
F	Front flange
G	Rear flange
C	Single rear clevis
D	Double rear clevis

**Bore size**

50	50mm
63	63mm
80	80mm
100	100mm

**Auto switch**

—	Without auto switch
---	---------------------

\* Refer to table below for selection of applicable auto switch.

**Number of auto switches**

—	2
S	1
3	3
n	n

**Rod specifications**

—	Hard chrome as standard
W	Double/through rod

**Stroke (mm)**

Refer to standard stroke table on p.5-23 maximum 1000mm

### Applicable Auto Switches/Direct mounting type

Type	Special function	Electrical entry	Indicator light	Wiring (output)	Load voltage		Auto switch model		Lead wire length (m) <sup>Note)</sup>			Applicable load	Mounting bracket	
					DC	AC	Vertical	Lateral	0.5 (Nil)	3 (L)	5 (Z)			
Reed switch	—	Grommet	Yes	3 wire	—	5V	—	Z76	●	●	—	IC circuit	BMP1-032	
				2 wire	24V	—	100V	Z73	●	●	●	—		Relay PLC
				No	5V, 12V	100V or less	Z80	●	●	—	—	—		IC circuit
Solid state switch	—	Grommet	Yes	3 wire (NPN)	24V	5V, 12V	—	Y69A	Y59A	●	●	○	Relay PLC	
				3 wire (PNP)				Y7PV	Y7P	●	●	○		
				2 wire				Y69B	Y59B	●	●	○		
				3 wire (NPN)				Y7NWV	Y7NW	●	●	○		
				3 wire (PNP)				Y7PWV	Y7PW	●	●	○		
				2 wire				Y7BWV	Y7BW	●	●	○		
				Water resistant (2 colour indicator)				—	Y7BA	—	●	—		—
—	Connector and Grommet	Yes	3 wire (NPN)	24V	5V, 12V	—	M9NV	M9N	●	●	○	IC circuit	BMP1-032 + BMG2-012	
			3 wire (PNP)				M9PV	M9P	●	●	○			
			2 wire				M9BV	M9B	●	●	○			

\* Lead wire length 0.5m..... — (Example: A53)  
 3m..... L (Example: A53L)  
 5m..... Z (Example: A53Z)

○: Manufactured upon receipt of order.

### Auto Switch Mounting Accessories for D-M9

Bore size (mm)	Order No.
ø32~ø100	BMP1-032
	BMG2-012

Note: For the mounting of auto switch D-M9, both BMP1-032 and BMG2-012 are necessary.

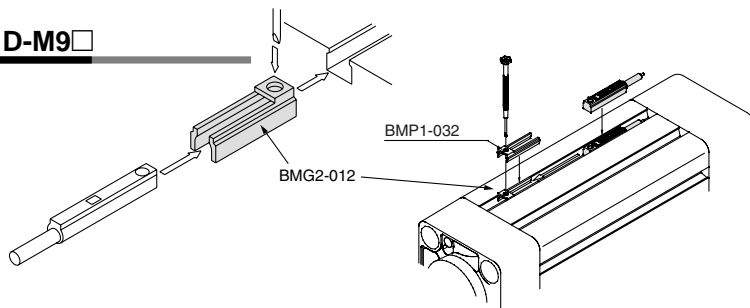

# Cylinder Series CP95N with lock

## Cylinder Specifications

Bore Size [mm]	32, 40, 50, 63, 80, 100
Fluid	Air
Proof Pressure	1.5MPa
Max. operating pressure	1.0MPa
Min. operating pressure	0.08MPa
Piston speed	50 to 1000mm/s <small>note)</small>
Ambient and fluid temperature	Without autoswitch : -10°C to 70°C (without freezing) With autoswitch : -10°C to 70°C (without freezing)
Cushion	Double air side cushion
Stroke length tolerance	to 250: $^{+1.0}_0$ , 251 to 1000: $^{+1.4}_0$
Bracket type	Basic type, Axial foot type, Front flange type, Rear flange type, Single clevis type, Double clevis type, Spherical bearing
max. possible stroke [mm]	1000

Note) Load limits exist depending upon piston speed when locked, mounting direction and operating pressure.

## Lock Specifications

Lock actuation	Spring lock (exhaust lock)
Unlocking pressure	$\geq 0.25$ MPa
Locking pressure	$\geq 0.20$ MPa
Max. operating pressure	1.0MPa
Locking direction	2 Two-way

## Standard Stroke

Bore Size [mm]	Standard Stroke [mm]	Max. Stroke
32	25,50,75,100,125,150,175,200,250,300,350,400,450,500	700
40	25,50,75,100,125,150,175,200,250,300,350,400,450,500	800
50	25,50,75,100,125,150,175,200,250,300,350,400,450,500,600	1000
63	25,50,75,100,125,150,175,200,250,300,350,400,450,500,600	
80	25,50,75,100,125,150,175,200,250,300,350,400,450,500,600,700,800	
100	25,50,75,100,125,150,175,200,250,300,350,400,450,500,600,700,800	

Intermediate strokes are available.

\* Please consult with SMC for longer stroke.

## Stopping Accuracy

[mm]

Locking system	Piston speed [mm/s]			
	100	300	500	1000
Spring lock	$\pm 0.3$	$\pm 0.6$	$\pm 1.0$	$\pm 2.0$

Conditions/Horizontal supply pressure P=0.5MPa

Load weight ..... Upper limit of allowable value

Solenoid valve for locking mounted on the locking pdr

Maximum value of stopping position dispersion from 100 measurements

## Spring Lock Holding Power (Maximum static Load)

Bore size [mm]	32	40	50	63	80	100
Holding power [N]	552	882	1370	2160	3430	5390



Cylinder with lock

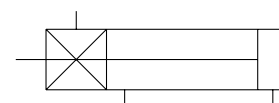

Quick Reference Guide

C55

C85

C76

CP95

C95

-X  
(Made to Order)

D-  
(Auto Switch)

Model Selection Procedures

## CP95N Cylinder

### Part No: Mounting Bracket, Mounting Accessories

Description	Bore size	ø32	ø40	ø50	ø63	ø80	ø100
L	Foot <sup>(1)</sup>	L5032	L5040	L5050	L5063	L5080	L5100
F,G	Flange	F5032	F5040	F5050	F5063	F5080	F5100
C	Single rear clevis	C5032	C5040	C5050	C5063	C5080	C5100
D	Double rear clevis	D5032	D5040	D5050	D5063	D5080	D5100
DS	Double rear clevis (for ES accessory)	DS5032	DS5040	DS5050	DS5063	DS5080	DS5100
ES	Angled rear clevis with ball joint	ES5032	ES5040	ES5050	ES5063	ES5080	ES5100
E	Angled rear clevis	E5032	E5040	E5050	E5063	E5080	E5100
GKM	Rod clevis	GKM10-20	GKM12-24	GKM16-32	GKM16-32	GKM20-40	GKM20-40
KJ	Piston rod ball joint	KJ16D	KJ12D	KJ16D	KJ16D	KJ20D	KJ20D
JA	Floating joint	JA30-10-125	JA40-12-125	JA50-16-150	JA50-16-150	JA80-20-150	JA100-20-150

- Note 1) Two foot brackets required for one cylinder.  
 Note 2) Accessories for each mounting bracket are as follows:Foot, Flange, Single clevis: Mounting bolts  
 Double rear clevis: (D,DS): Clevis pin  
 Note 3) GKM according to ISO 8140  
 Note 4) KJ according to ISO 8139  
 Note 5) Piston rod nut is standard

### Single Rod Weight Table

Bore Size [mm]		32	40	50	63	80	100
Basic weight	Basic type B	1.40	2.15	3.53	5.18	8.99	12.72
Additional weight per 50mm of stroke	All mounting brackets	0.11	0.16	0.26	0.27	0.42	0.56

(Example) CP95NDB32-100 (Standard, Ø32, 100er)

- Basic weight..... 1.40 (basic type, Ø32)
- Additional weight ..... 0.11/50mm stroke
- Cylinder stroke ..... 100mm stroke

$$1.40 + 0.11 \times 100/50 = 3.02\text{kg}$$

### Manual override for unlocking

In case the air supply is cut off or discharged, unlocking can be performed with a commercially available tool. The fail safe mechanism locks again when manual override is released.

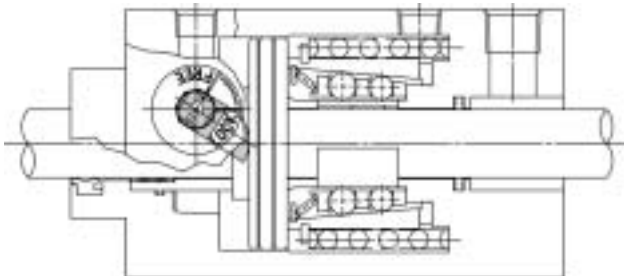

### Weight accessories [kg]

Ø	32	40	50	63	80	100
L	0.16	0.20	0.38	0.46	0.89	1.09
F	0.20	0.23	0.47	0.58	1.30	1.81
C	0.16	0.23	0.37	0.60	1.07	1.73
D	0.20	0.32	0.45	0.71	1.28	2.11

### Example:

Cylinder Ø40 mm, Stroke 100 mm, bracket D

$$\text{Weight} = 0.84 \text{ kg} + \left(0.16 \text{ kg} \times \frac{100}{50}\right) + 0.32 \text{ kg} = 1.48 \text{ kg}$$

### Construction Principles

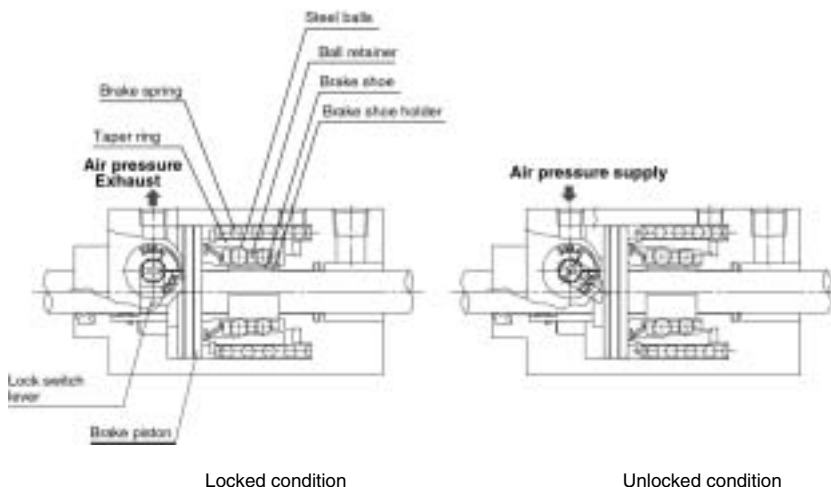

### Spring lock (exhaust lock)

The spring force which acts upon the taper ring is magnified by a wedge effect, and is conveyed to all of the numerous steel balls which are arranged in two circles. These act on the brake shoe holder and brake, which locks the piston rod by tightening against it with a large force.

Unlocking is accomplished when air pressure is supplied to the unlocking port. The brake piston and taper ring oppose the spring force, moving to the right side, and the ball retainer strikes the cover section A. The braking force is released as the steel balls are removed from the taper ring by the ball retainer.

## Construction

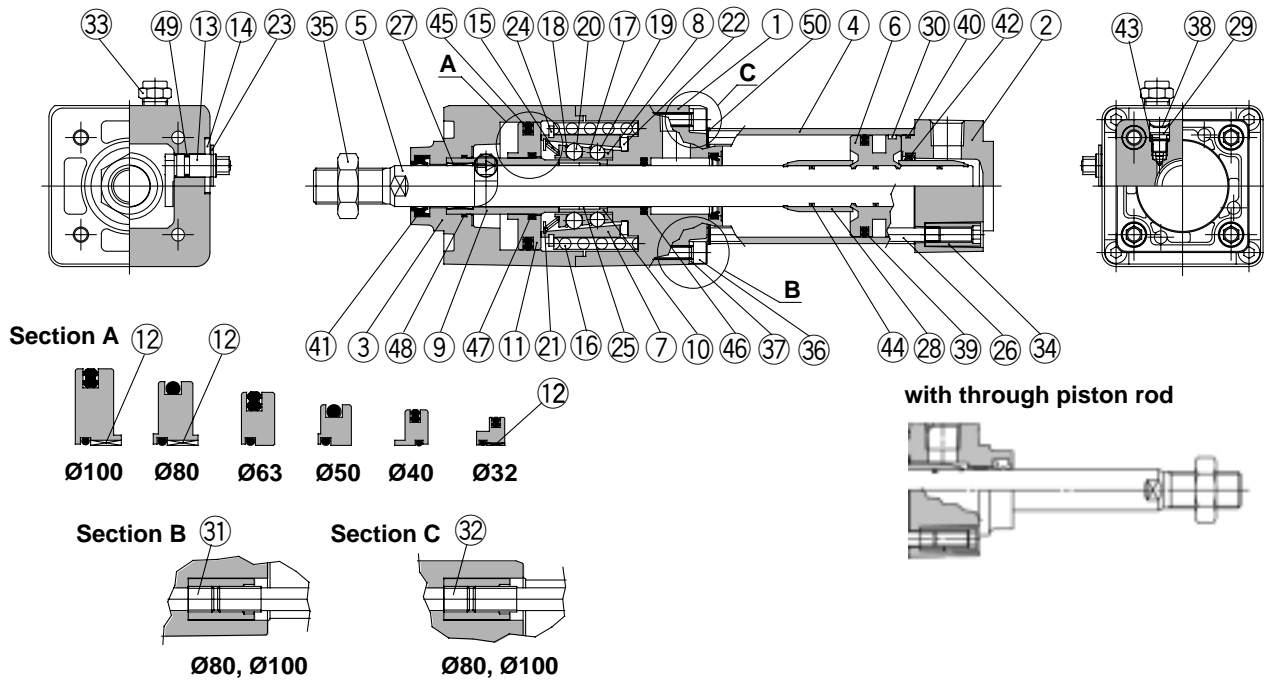

### Parts list

No.	Description	Material	Note	
①	Rod cover	Aluminium alloy	Hard anodised & metallic coated	
②	Head cover	Aluminium alloy	Chromated & metallic coated	
③	Cover	Aluminium alloy	Hard anodised & metallic coated	
④	Cylinder tubing	Aluminium alloy	Hard anodised	
⑤	Piston rod	Carbon steel	Hard chrome plated	
⑥	Piston	Aluminium alloy	Chromated	
⑦	Taper Ring	Carbon steel	Heat treated	
⑧	Ball retainer	Special resin		
⑨	Piston guide	Carbon steel	Zinc chromated	
⑩	Brake shoe holder	Carbon steel	Heat treated	
⑪	Release piston	Ø40	Aluminium alloy Hard anodised	
		Ø50		
		Ø63		
		Ø32		Carbon steel Zinc chromated
		Ø80		
		Ø100		
⑫	Release piston bushing	Steel + special resin	Ø32, Ø80, Ø100 only	
⑬	Unlocking cam	Carbon steel	Glossy chromated	
⑭	Washer	Carbon steel	Black zinc chromated	
⑮	Retainer pre-load spring	Carbon steel	Zinc chromated	
⑯	Brake spring	Carbon steel	Zinc chromated	
⑰	Clip A	Stainless steel		
⑱	Clip B	Stainless steel		
⑲	Steel ball A	Carbon steel		
⑳	Steel ball B	Carbon steel		
㉑	Tooth ring	Stainless steel		
㉒	Damper	Polyurethane rubber		
㉓	C type retaining ring for unlocking cam shaft	Carbon steel		
㉔	C type retaining ring for taper ring	Carbon steel		
㉕	Brake shoe	Special friction material		
㉖	Tie rod	Carbon steel	Chromated	
㉗	Bushing	Lead-bronze casting		
㉘	Cushion ring	Brass		

### Parts list

No.	Description	Material	Note
㉙	Cushion valve	Carbon steel	Nickel plated
⑳	Wear ring	PUR	
㉑	Unit holding tie-rod A	Carbon steel	Chromated Ø80, Ø100 only
㉒	Unit holding tie-rod B	Carbon steel	Chromated Ø80, Ø100 only
㉓	BC element		
㉔	Tie-rod nut	Carbon steel	Nickel plated
㉕	Rod end nut	Carbon steel	Nickel plated
㉖	Hexagon socket head cap screw	Carbon steel	Nickel plated Ø32, Ø63 only
㉗	Spring washer for hex. socket head cap screw	Carbon steel	Nickel plated Ø32, Ø63 only
㉘	Retaining ring	Carbon steel	
㉙	Piston seal	NBR	
㉚	Cylinder tube gasket	NBR	
㉛	Rod seal A	NBR	
㉜	Cushion seal	NBR	
㉝	Cushion valve seal	NBR	
㉞	Piston gasket	NBR	
㉟	Release piston gasket	NBR	
㊱	Rod seal B	NBR	
㊲	Release piston gasket	NBR	
㊳	Piston guide gasket	NBR	
㊴	Unlocking cam gasket	NBR	
㊵	Spacer disc	CR	

# Series CP95N

## Dimensions

### Basic type (B)

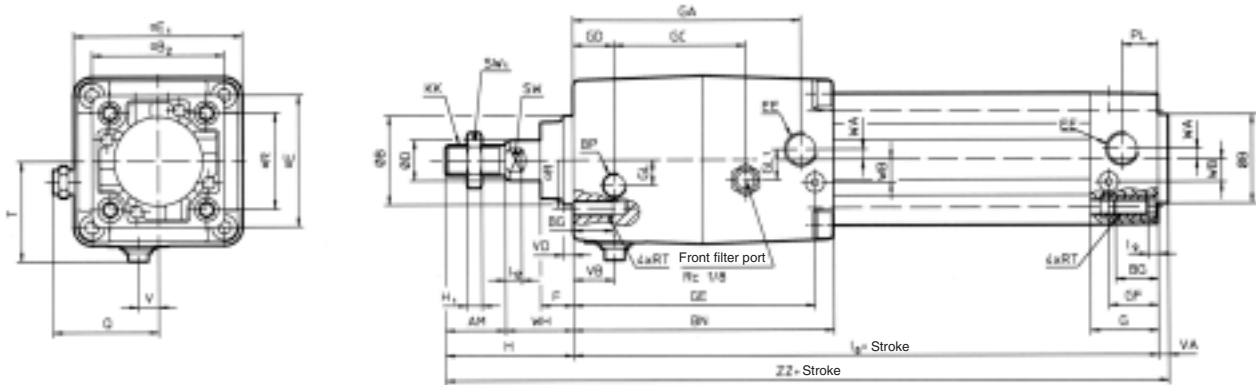

Bore size (mm)	AM	$\phi B_e$ 11	$\phi B_2$	BG	BN	BP	$\phi D$	EE	$\phi E$	$\phi E_1$	F	G	GA	GC	GD	GE	GF	GL	GL <sub>1</sub>	H	H <sub>1</sub>
32	22	30	46	16	97	G1/8	12	G1/8	46	54	13	27	83	45.5	13	88.5	18.3	7.5	12	48	6
40	24	35	52	16	104	G1/8	16	G1/4	52	63	13	27	91	52.5	16.5	96.5	19.5	10	12	54	8
50	32	40	65	16	120.5	G1/4	20	G1/4	65	75	14	31.5	104.5	58.5	19	111.2	22.4	11.5	15	69	11
63	32	45	75	16	134.5	G1/4	20	G3/8	75	90	14	31.5	119.5	68	23	123.5	20.7	17.5	12	69	11
80	40	45	95	16	169	G1/4	25	G3/8	95	102	20	38	150	81	33	157	26	22	18	86	13
100	40	55	114	16	189	G1/4	30	G1/2	114	116	20	38	170	96	37.5	177	26	25	20	91	16

Bore size (mm)	KK	$I_8$	$I_9$	$I_{12}$	PL	Q	$\phi R$	RT	SW	SW <sub>1</sub>	T	V	VA	VB	VD	WA	WB	WH	ZZ
32	M10 x 1.25	164	4	6	13	37	32.5	M6	10	17	34	6.5	4	13	4	4	6.5	26	216
40	M12 x 1.25	182	4	6.5	14	41.5	38	M6	13	19	39.5	8	4	16.5	4	4	9	30	240
50	M16 x 1.5	195	5	8	15.5	47.5	46.5	M8	16	24	47	9	4	20	6	5	10.5	37	268
63	M16 x 1.5	224	5	8	16.5	55	56.5	M8	16	24	55.5	8.5	4	23	6	9	12	37	297
80	M20 x 1.5	259	5	10	19	61	72	M10	21	30	61.5	10.5	4	33	8	11.5	14	46	349
100	M20 x 1.5	289	5	10	19	68	89	M10	21	30	69.5	10.5	4	37.5	8	17	15	51	384



# Series CP95N

## Dimensions Brackets on Cylinder

### Axial Foot Type

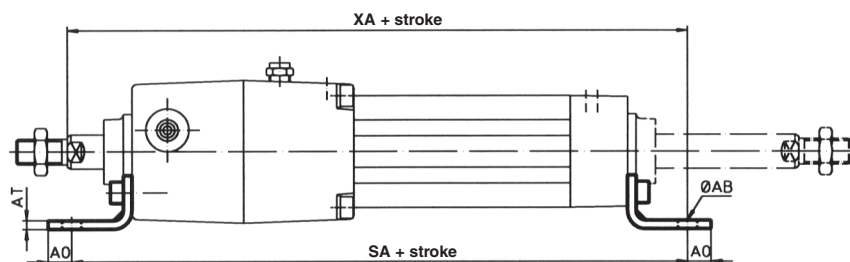
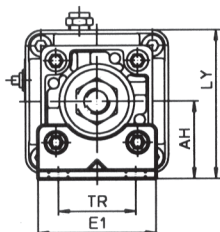

### Rear Flange Type

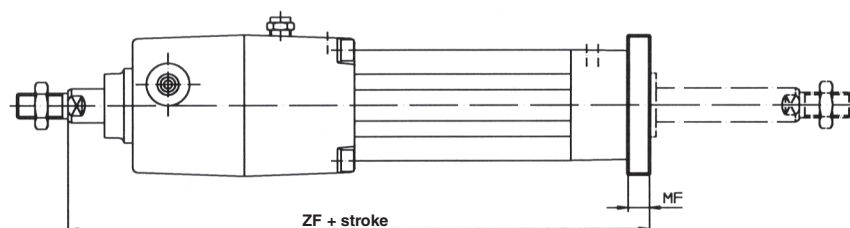
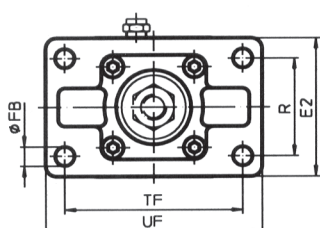

### Front Flange Type

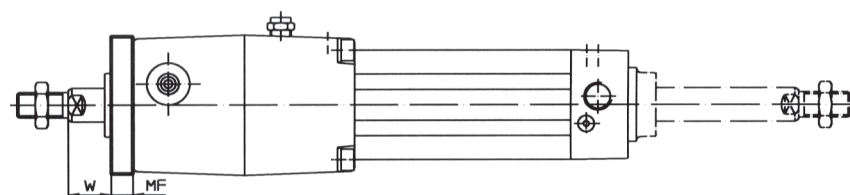

### Single Clevis Type

### Double Clevis Type

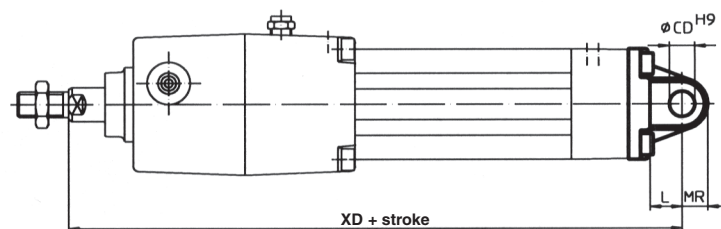
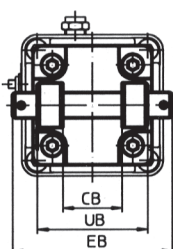
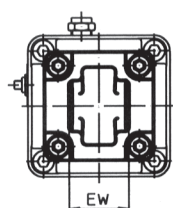

Bore size (mm)	Ø AB	AH	AO	AT	CB <sub>1</sub>	ØCD H9	E1	E2	EB	EW <sub>2</sub>	ØFB	L	LY	MF	MR	R	SA	TF	TR	UB	UF
32	7	32	10	4	26	10	48	56	65	26	7	12	59	10	9.5	38	212	72	32	45	87
40	9	36	11	4	28	12	55	65	75	28	9	15	67.5	10	12	46	238	83	36	52	101
50	9	45	12	5	32	12	68	77	80	32	9	15	82.5	12	12	45	259	90	45	60	120
63	9	50	12	5	40	16	80	92	90	40	9	20	95	12	16	62	288	115	50	70	135
80	12	63	14	6	50	16	100	100	110	50	12	20	114	16	16	63	341	126	63	90	153
100	14	71	16	6	60	20	120	120	140	60	14	25	129	16	20	75	371	150	75	110	178

1) +0.03/+0.1 2) -0.2/-0.6

Bore size (mm)	W	XA	XD	ZF
32	16	214	212	200
40	20	240	237	222
50	25	264	259	244
63	25	293	293	273
80	30	346	341	321
100	35	381	381	356



# Series CP95N Specific Product Precaution

## Air Pressure Circuits

### Warning

#### 1. Basic Circuits

##### 1. [Horizontal]

Forward

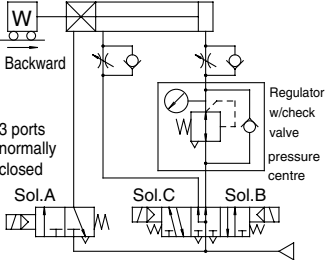

##### 2. [Vertical]

[ Load in direction of rod extension ]

[ Load in direction of rod retraction ]

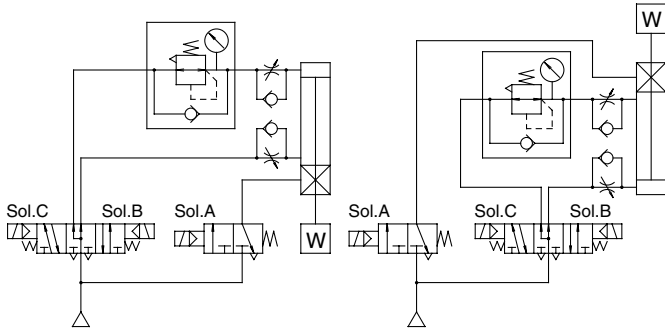

### Caution

- A 3 position pressure centre solenoid valve and regulator with check valve can be replaced with two 3 port normally open valves and a regulator with relief function.

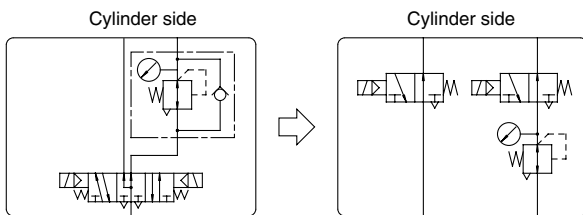

[Example]

##### 1. [Horizontal]

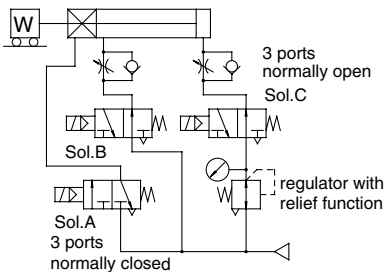

## Air Pressure Circuits

### Caution

#### 2. [Vertical]

[ load in direction of rod extension ]

[ Load in direction of rod retraction ]

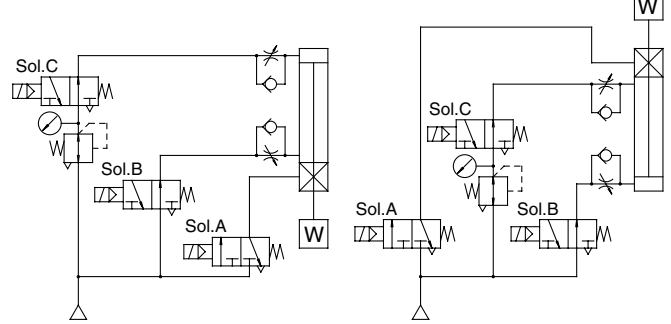

## Manual Unlocking

### Caution

- The unlocking cam provided on the C95N Series is an emergency unlocking mechanism only. During an emergency when the air supply is cut off, it is used to alleviate a problem by forcibly pushing the release piston back to release the lock. However, take note that the sliding resistance of the piston rod will be high compared to unlocking with air pressure.
- When installing into equipment or machinery, etc., in cases where it will be necessary to hold an unlocked condition for an extended time, air pressure of 0.25MPa or more should be applied to the unlocking port.
- Do not turn the unlocking cam (the arrow ← on the unlocking cam head) past the FREE position. If it is turned too far there is a danger of damaging the unlocking cam.

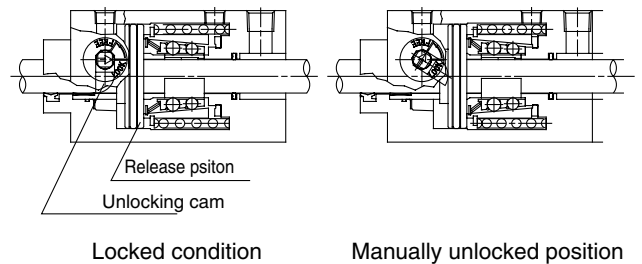

[Principle]

If the unlocking cam is turned counter clockwise with a tool such as an adjustable angle wrench, the release piston is pushed back and the lock is released. Since the lever will return to its original position when released and become locked again, it should be held in this position for as long as unlocking is needed.

## Precautions on Model Selection

### ⚠ Caution

Example

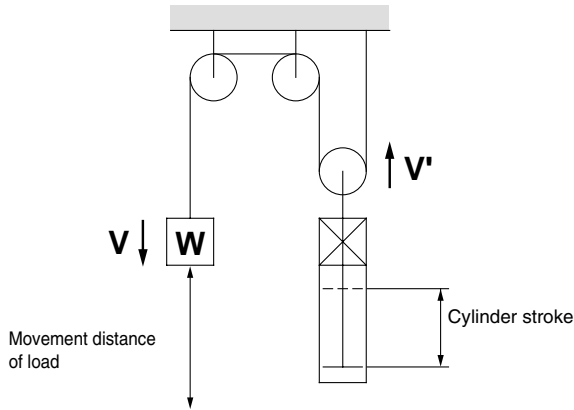

### Selection Example

- **Load weight:**  $m=50\text{kg}$
- **Movement distance:** Stroke=500mm
- **Movement time:**  $t=2\text{s}$
- **Load condition:** Vertical downward=Load in direction of rod extension
- **Operating pressure:**  $P=0.4\text{MPa}$

Step 1: From graph 1 find the maximum movement speed of the load  
 $\therefore$  Maximum speed  $V$ : approx 350mm/s

Step 2: Select graph 6 based upon the load condition and operating pressure, and then from the intersection of the maximum speed  $V=350\text{mm/s}$  found in step 1, and the load weight  $m=50\text{kg}$   
 $\therefore \text{Ø63}$  →selecta C95NDB63 or larger bore size.

## Step 1 Find the maximum load speed: V

Graph 1

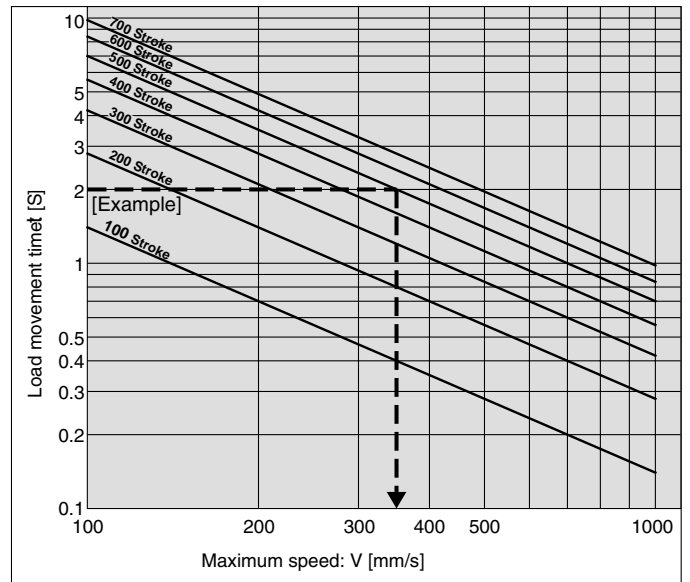

## Step 2 Find the cylinder bore size

Load condition

Operating pressure

Direction of load at right angle to rod  
 (\*  $\theta$  Being held by a guide)

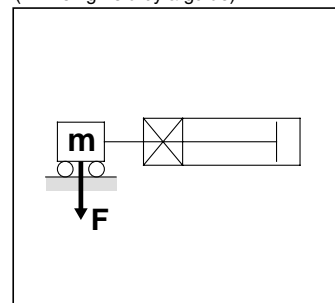

from 0.3MPa → Graph 2

from 0.4MPa → Graph 3

from 0.5MPa → Graph 4

Load in direction of rod extension  
 Load in direction of rod retraction

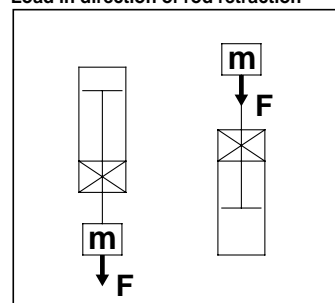

from 0.3MPa → Graph 5

from 0.4MPa → Graph 6

from 0.5MPa → Graph 7

## Selection Graphs

### Graph 2

0.3MPa<sup>a</sup> P<0.4MPa

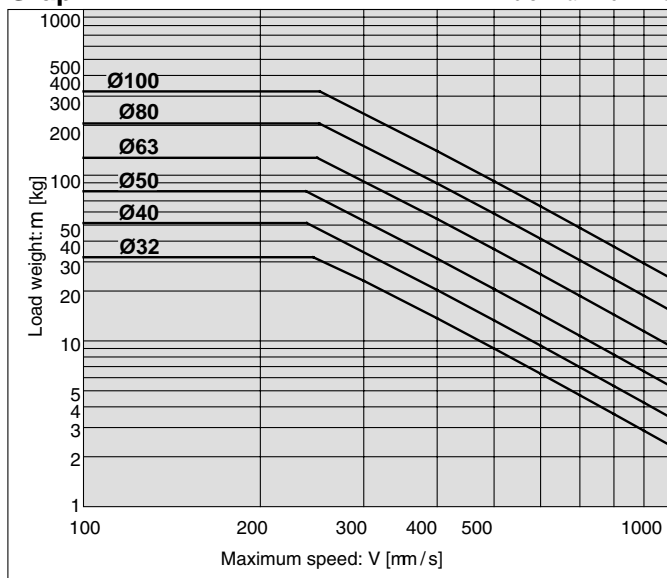

### Graph 5

0.3MPa<sup>a</sup> P<0.4MPa

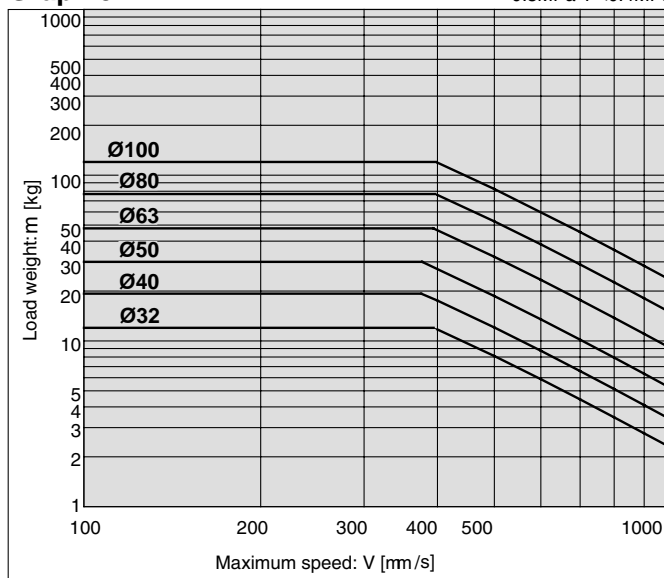

### Graph 3

0.4MPa<sup>a</sup> P<0.5MPa

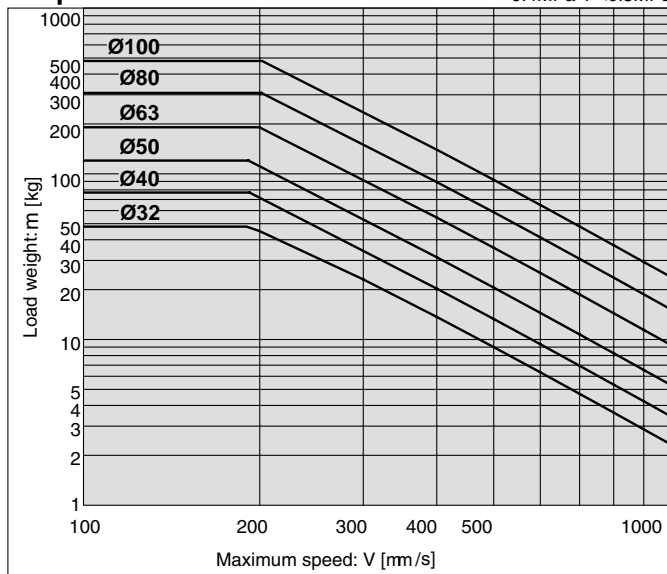

### Graph 6

0.4MPa<sup>a</sup> P<0.5MPa

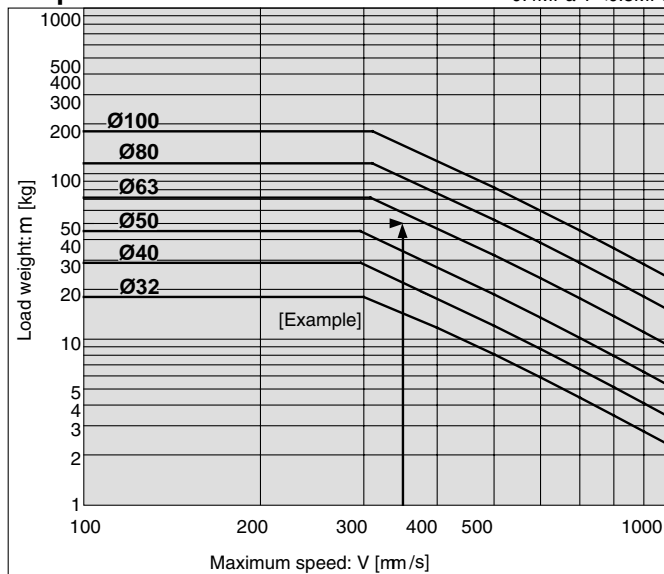

### Graph 4

0.5MPa<sup>a</sup> P

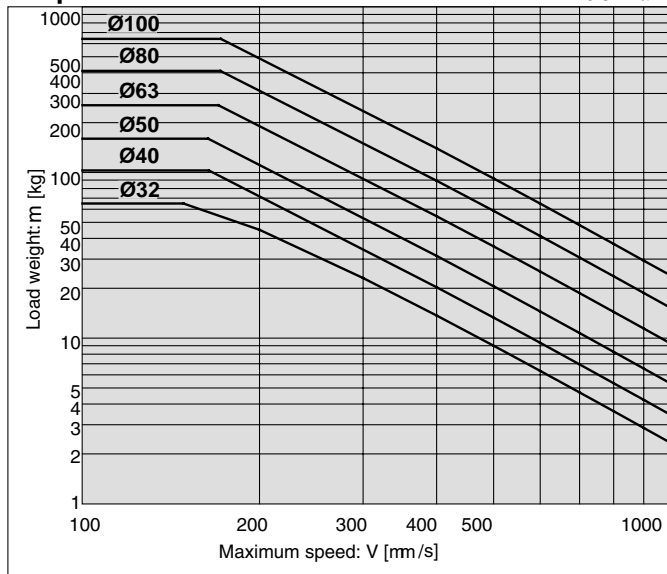

### Graph 7

0.5MPa<sup>a</sup> P

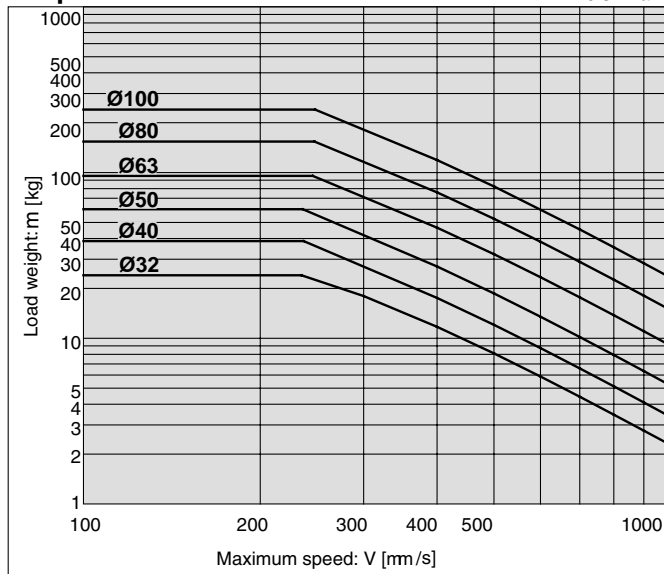

Quick Reference Guide

C55

C85

C76

CP95

C95

-X (Made to Order)

D- (Auto Switch)

Model Selection Procedures

# Series CP95

## Auto switch mounting

[mm]



### Minimum strokes for auto switches

Auto switch type	Model	Amount* of switches	Ø32	Ø40	Ø50	Ø63	Ø80	Ø100
Reed	D-Z73L	2 pcs.	25				15	
	D-Z80L	1 pcs.						
Solid state	D-Y59BL	2 pcs.	25				15	
	D-Y69BL	1 pcs.						
	D-Y7PL							

\*Auto switches are mounted on the same side but in different grooves of the cylinder.

## Recommended mounting position for stroke ends

[mm]

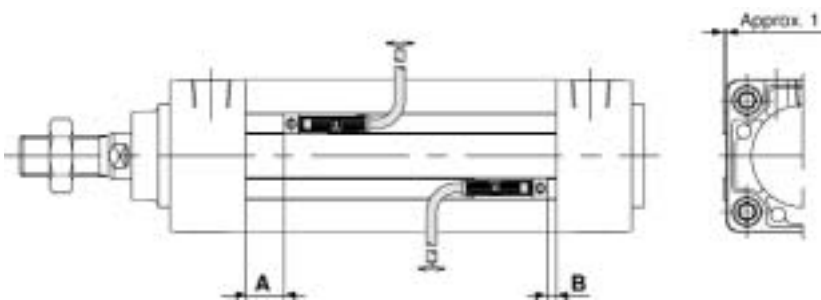

Bore (mm)	D-Z73L, D-Z80L, D-Y7PL D-Y59BL, D-Y69BL	
	A	B
32	14	1
40	25	1
50	16	2
63	31	2
80	21.5	5.5
100	31.5	5.5

## Mounting of Auto Switches

1N·m: approx. 10.2kgf·cm

When attaching an auto switch, first take a switch holder between your fingers and press it into a switch mounting groove. When doing this, confirm that it is set in the correct mounting orientation, or reattach if necessary. Next, insert an auto switch into the groove and slide it until it is positioned under the switch holder. After establishing the mounting position, use a watchmakers flat head screw driver to tighten the switch mounting screw which is included.

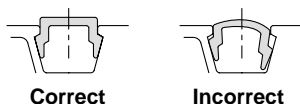

Switch holder: BMP1-032

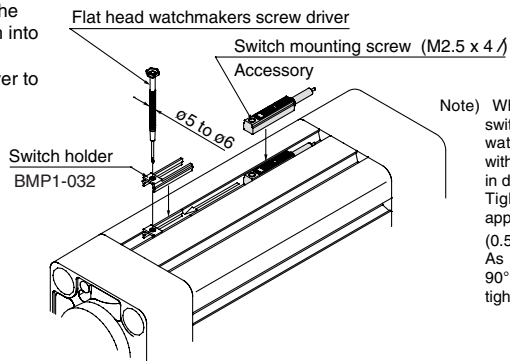

Note) When tightening the auto switch mounting screw, use a watchmakers screw driver with a handle about 5 to 6mm in diameter. Tighten to a torque of approximately 0.05 to 0.1Nm (0.51 to 1.02kgf·cm). As a rule, it is turned about 90° past the point at which tightening can be felt.

## How to order: Auto Switches, holders and Groove Covers

### Auto switch holder band

Ø	Order No.	
	Auto switch	Switch holder
32	D-Z73L	BMP1-032
40	D-Z80L	
50	D-Y7PL	
63	D-Y59BL	
80	D-Y69BL	
100		

### Groove cover of square tube

Ø	Order No.	Cylinder length without stroke
32	CP95-AL	41.5 mm
40		52.5 mm
50		44.5 mm
63		59.5 mm
80		53.5 mm
100		63.5 mm

Groove covers are available in progressive rates of 1 metre. Please, indicate round figures when ordering.

Write the required length of the groove cover in the box.

Order example: Groove cover for CP95SB63-160

59.5 mm + 160 mm = 239.5 x 8 grooves = 1916 mm  
 [Cylinder length without stroke] [Stroke] [8 grooves in the square tube]

Length to order: 1916 mm corresponds to a groove cover of 2 m for each cylinder  
 Order No.: CP95-AL  length in metres



# Series CP95 Specific Product Precautions

## Adjustment

### ⚠ Warning

- ① **Do not open the cushion valve above the stopper.**  
Cushion valves are provided with a crimp ( $\phi 32$ ) or a retaining ring ( $\phi 40$  to  $\phi 100$ ) as a stopping mechanism, and the cushion valve should not be opened above that point.  
If air is supplied and operation started without confirming the above condition, the cushion valve may be ejected from the cover.

Bore size (mm)	Cushion valve	Width across flats	Socket wrench
32, 40, 50	MB-32-10-C1247	2.5	JIS 4648 Hex spanner wrench 2.5
63, 80, 100	MB-63-10-C1250	4	JIS 4648 Hex spanner wrench 4

- ② **When replacing brackets, use the hexagon wrenches shown below.**

Bore size (mm)	Bolt	Width across flats	Tightening torque (Nm)
32, 40	MB-32-48-C1247	4	4.9
50, 63	MB-50-48-C1249	5	11
80, 100	Foot Others	6	25
	MB-80-48AC1251		
	MB-80-48BC1251		

## With Non-rotating Rod (Double Acting: Single Rod)

### Operating Precautions

### ⚠ Caution

- ① **Do not apply more than the allowable rotating torque to the piston rod.**  
If more than the allowable rotating torque is applied, the non-rotating guide will be deformed and there will be a significant loss of rotational accuracy. This may cause damage to the machinery.

### Mounting & Piping

### ⚠ Caution

- ① **Mounting of a work piece at the rod end.**  
When screwing a fitting or nut, etc. onto the threads at the end of the piston rod, push the piston rod into its fully retracted position, and grasp the protruding section with a wrench.  
Furthermore, when tightening, take care that the torque is not applied to the non-rotating guide.

