

# ZNC Series Model Selection

## Selection Procedure

### [Basic type]

#### Step 1 Calculate the lifting force.

$$W = M \times g \times t \times \frac{1}{n}$$

**W**: Required lifting force [N]

**M**: Workpiece mass [kg]

**g**: Gravitational acceleration [= 9.8 m/s<sup>2</sup>]

**t**: Safety factor (Recommended value: 2 or more)

**n**: Number of Bernoulli grippers [pcs.]

#### Selection example

Workpiece mass: **M** = 0.7 kg

Safety factor: **t** = 2

Number of Bernoulli grippers: **n** = 2 pcs.

Required lifting force: **W** =  $0.7 \times 9.8 \times 2 \times \frac{1}{2} = 6.9 \text{ N}$

#### Basic type

Workpiece: Smooth and non-permeable

Operating pressure: 0.3 MPa

#### Step 2 Model selection

##### Lifting Force (ZNC40)

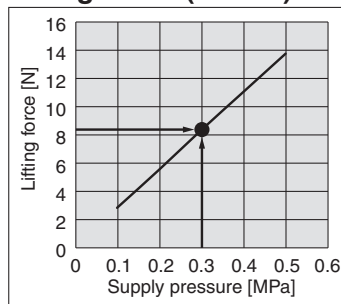

The lifting force in relation to the supply pressure for each size can be confirmed using the graph.

For the ZNC40, as the lifting force is 8.4 N when the supply pressure is 0.3 MPa, the lifting force is greater than the required lifting force. Therefore, the product can be used. If the lifting force is less than the required lifting force, considering rethinking the size, number of grippers to be used, or operating pressure.

The lifting force changes depending on the shape, size, surface unevenness, breathability, flexibility, etc., of the workpiece. Use the selection result as a reference value and perform verification and confirmation on the actual machine.

### [With stopper/vibration suppression cover]

#### Step 1 Calculate the lifting force.

$$W = M \times g \times t \times \frac{1}{n}$$

**W**: Required lifting force [N]

**M**: Workpiece mass [kg]

**g**: Gravitational acceleration [= 9.8 m/s<sup>2</sup>]

**t**: Safety factor (Recommended value: 2 or more)

**n**: Number of Bernoulli grippers [pcs.]

#### Selection example

Workpiece mass: **M** = 0.25 kg

Safety factor: **t** = 2

Number of Bernoulli grippers: **n** = 1 pc.

Required lifting force: **W** =  $0.25 \times 9.8 \times 2 \times \frac{1}{1} = 4.9 \text{ N}$

#### With stopper

Workpiece: Smooth and non-permeable

Operating pressure: 0.4 MPa

#### Step 2 Model selection

##### Lifting Force–Distance from the Workpiece (ZNC40)

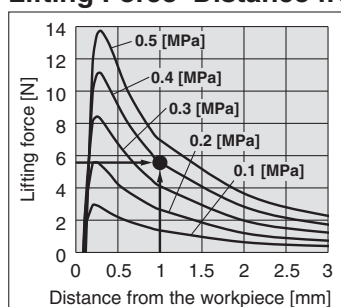

The lifting force in relation to the distance from the workpiece for each size can be confirmed using the graph.

In addition, for the type with a stopper, confirm the lifting force at 1 mm.

(For the type with a vibration suppression cover, confirm the lifting force at 1.5 mm.)

For the ZNC40, as the lifting force is 5.5 N when the supply pressure is 0.4 MPa, the lifting force is greater than the required lifting force. Therefore, the product can be used. If the lifting force is less than the required lifting force, considering rethinking the size, number of grippers to be used, or operating pressure.

The lifting force changes depending on the shape, size, surface unevenness, breathability, flexibility, etc., of the workpiece. Use the selection result as a reference value and perform verification and confirmation on the actual machine.

# Bernoulli Gripper ZNC Series

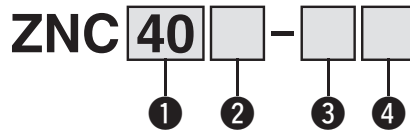

## How to Order



### 1 Body size

30	∅ 30 mm
40	∅ 40 mm
60	∅ 60 mm
80	∅ 80 mm

### 2 Body material



—	Aluminium	
P	Resin	
S	Stainless steel	

### 3 Attachment

—	Basic type (Without attachment)	
PN	With stopper	NBR (Black)
PS		Silicone rubber (White)
VP	With vibration suppression cover*1	Resin
VS		Stainless steel



### 4 Pressure sensor

—	None	
S	With pressure sensor Part no.: PSE541-M5-X2	

\* The pressure sensor is shipped together with the product but does not come assembled.

- \*1 Refer to the Table 1 . With Vibration Suppression Cover for the size and material.
- \* Stopper cannot be added afterward.
- \* Vibration suppression cover can be added to the basic type afterward.
- \* The stopper and vibration suppression cover cannot be used together.

Table 1. With Vibration Suppression Cover

Symbol	Material	Body size symbol	Body material		
			Aluminium	Resin	Stainless steel
VP	Resin	30	—	—	—
		40	●	●	—
		60	—	—	—
		80	—	—	—
VS	Stainless steel	30	●	●	●
		40	●	—	●
		60	●	●	●
		80	●	●	●

## Attachments/Part Nos.

### Stopper

ZNCM - **PS** **2**

\* Stopper size 1: With 3 stoppers  
Stopper size 2: With 3 stoppers and 3 spring pins  
For replacement instructions ⇨ Refer to page 10.

#### Material

PN	NBR (Black)
PS	Silicone rubber (White)

#### Stopper size

Symbol	Body size
1	30
2	40, 60, 80

### Vibration suppression cover

ZNCM - **40** **VP**

\* For stainless steel:  
Body size ∅ 30 mm:  
With 2 mounting screws  
Body sizes ∅ 40 mm and ∅ 60 mm, and ∅ 80 mm  
With 3 mounting screws

#### Body size

30	∅ 30 mm
40	∅ 40 mm
60	∅ 60 mm
80	∅ 80 mm

#### Material

VP	Resin
VS	Stainless steel

\* Material: Resin is only selectable for body size 40.

# ZNC Series



## Specifications

Model		ZNC30	ZNC40	ZNC60	ZNC80	
Lifting force [N]*1, *3		10.7	13.8	28.3	65	
Air consumption [L/min] (ANR)*2, *3		138	182	182	255	
Type		Bernoulli				
Fluid		Air				
Operating pressure		0.1 to 0.5 MPa				
Proof pressure		0.75 MPa				
Ambient and operating temperatures*4	Body material	Aluminum	-5 to 80 °C (0 to 50 °C)			
		Resin	-5 to 40 °C (0 to 40 °C)			
		Stainless steel	-5 to 80 °C (0 to 50 °C)			
Grease		Grease-free				
Weight [g]*5	Body material	Aluminum	27	48	110	193
		Resin	17	30	67	119
		Stainless steel	77	139	323	568
Pressure sensor*6		PSE541-M5-X2 (Grease-free) Rated pressure range: 0 to -101 kPa				

\*1 Lifting force of the basic type for max. supply pressure. Values when a flat and non-breathable workpiece is adsorbed

\*2 Air consumption for max. supply pressure

\*3 (For the ZNC30, 40, and 60) The values are for when the connection is as follows: Fitting min. hole diameter: Ø 2.5, Tubing size: Ø 6 x Ø 4, Length: 500 mm

(For the ZNC 80) The values are for when the connection is as follows: Fitting min. hole diameter: Ø 4.5, Tubing size: Ø 6 x Ø 4, Length: 500 mm

\*4 No freezing or condensation. The values in ( ) are for models with a pressure sensor.

\*5 Weight for the basic type without a plug

\*6 For pressure sensor details, refer to the PSE 5 4 0 series in the **Web Catalogue** and the Operation Manual.

**ZNC30** □

**Lifting Force**

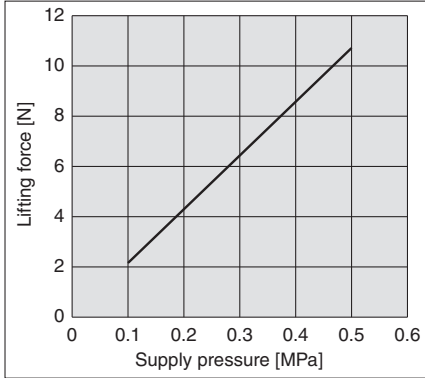

**Consumption Flow Rate**

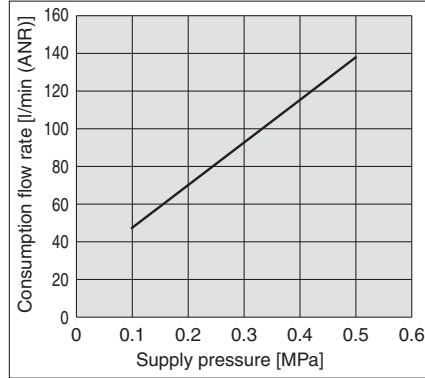

**Lifting Force–Distance from the Workpiece**

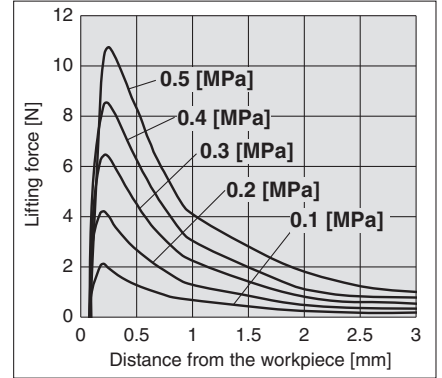

**ZNC40** □

**Lifting Force**

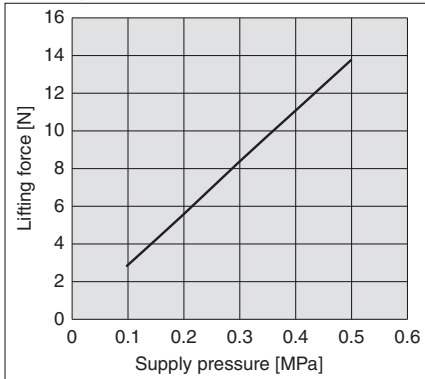

**Consumption Flow Rate**

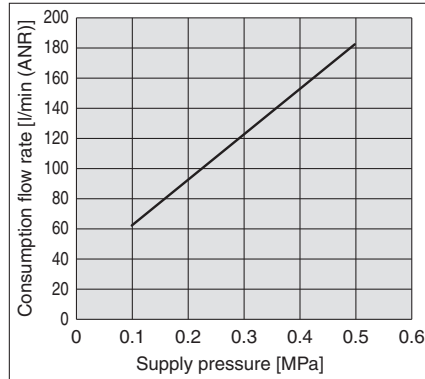

**Lifting Force–Distance from the Workpiece**

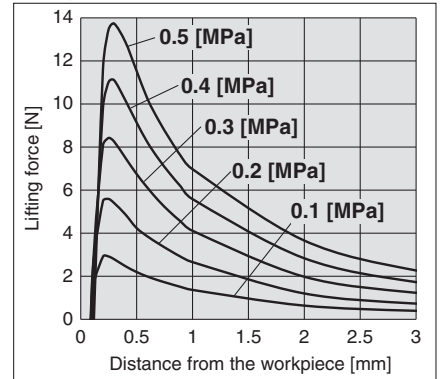

**ZNC60** □

**Lifting Force**

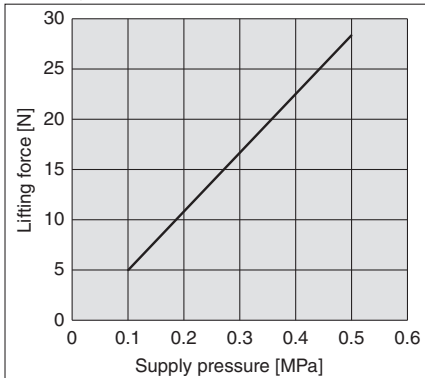

**Consumption Flow Rate**

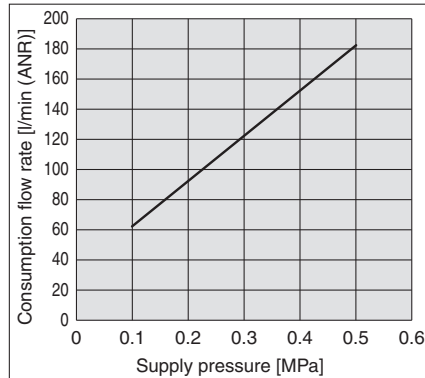

**Lifting Force–Distance from the Workpiece**

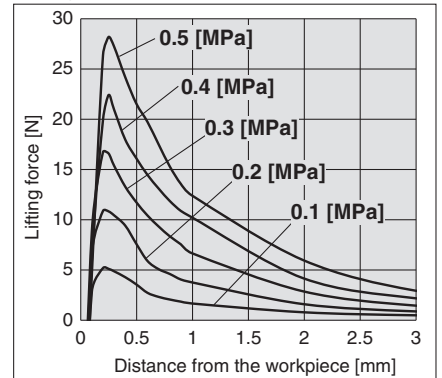

**ZNC80** □

**Lifting Force**

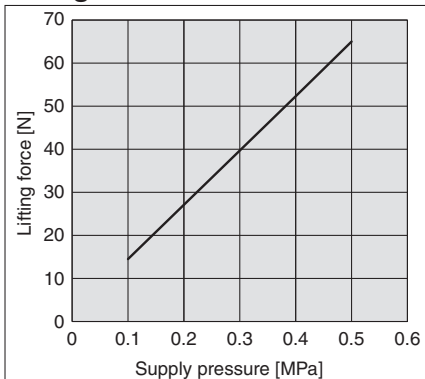

**Consumption Flow Rate**

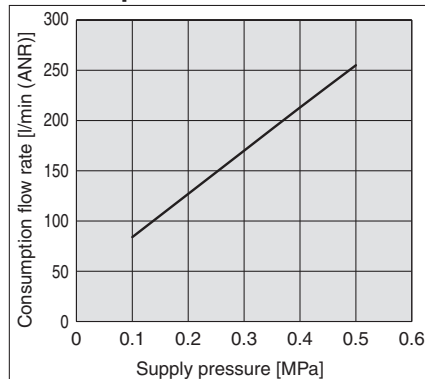

**Lifting Force–Distance from the Workpiece**

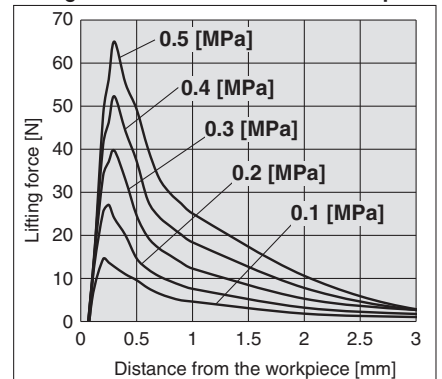

**Construction**

Ø 30

**Basic type**

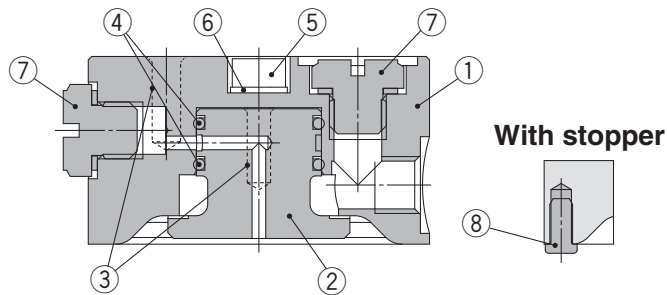

Ø 40

**With vibration suppression cover: Resin**

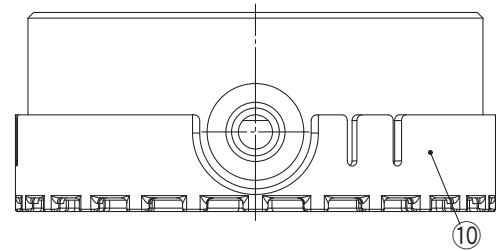

Ø 40, Ø 60

**Basic type**

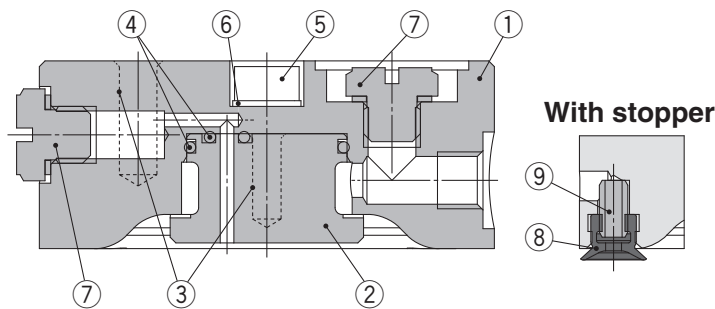

Ø 30, Ø 40, Ø 60, Ø 80

**With vibration suppression cover: Stainless steel**

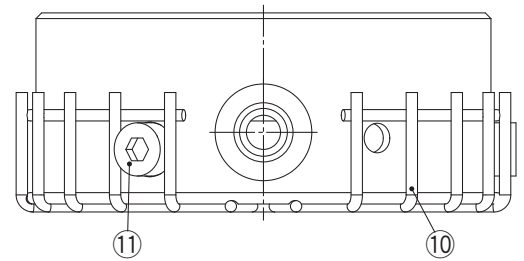

Ø 80

**Basic type**

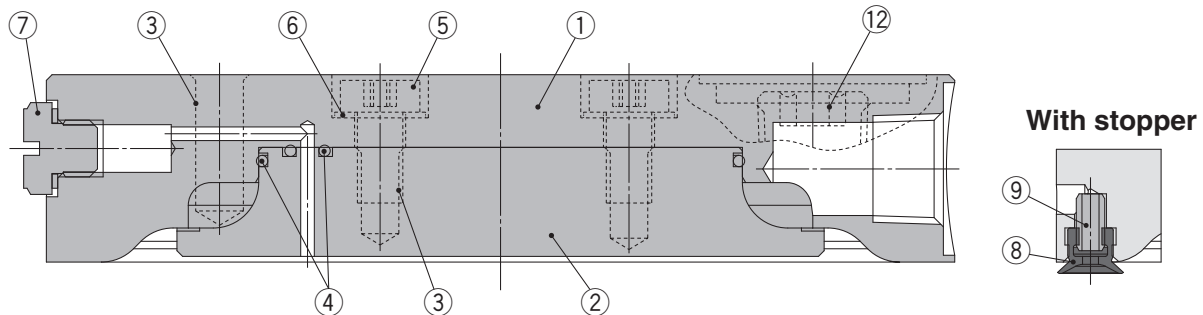

**Component Parts**

No.	Description	Material (Surface treatment)	Note	
1	Body	Aluminum alloy (Anodized)	Body material	For aluminum
		Synthetic resin	Body material	For resin
		Stainless steel	Body material	For stainless steel
2	Deflector	Aluminum alloy (Anodized)	Body material	For aluminum
		Synthetic resin	Body material	For resin
		Stainless steel	Body material	For stainless steel
3	Helical insert	Stainless steel	Body material	For resin
4	O-ring	FKM		
5	Hexagon socket head cap screw	Stainless steel		
6	Flat washer	Stainless steel		
7	Plug	Stainless steel/FKM		
8	Stopper	NBR	With stopper	Refer to page 4 for part numbers.
		Silicone rubber*1, *2		
9	Spring pin	Stainless steel		
10	Vibration suppression cover	Synthetic resin	With vibration suppression cover	
		Stainless steel		
11	Hexagon socket head cap screw	Stainless steel		
12	Hexagon socket head plug	Stainless steel		

**Replacement Parts**

**O-ring for Direct Porting**

Part no.	Applicable outer body dia.
ZNCM-30DR	Ø 30
ZNCM-40DR	Ø 40, Ø 60
ZNCM-80DR	Ø 80

\* Sales unit: 10 pcs.

\*1 Compliant with the FDA's (U.S. Food and Drug Administration) 21CFR§177.2600 dissolution test  
 \*2 Compliant with the standards for "Rubber apparatus (excluding baby drinking apparatus) and containers/packaging" (D3) (Partial revision: Japanese Ministry of Health, Labour, and Welfare Notification No. 595, 2012) in Section 3 "Apparatus and Containers/Packaging" of the Food Sanitation Act, Article 18 "Specifications and Standards for Food and Food Additives, etc." (Japanese Ministry of Health and Welfare Notification No. 370, 1959)

# ZNC Series

Dimensions:  $\varnothing 30$ ,  $\varnothing 40$ ,  $\varnothing 60$

## Basic type

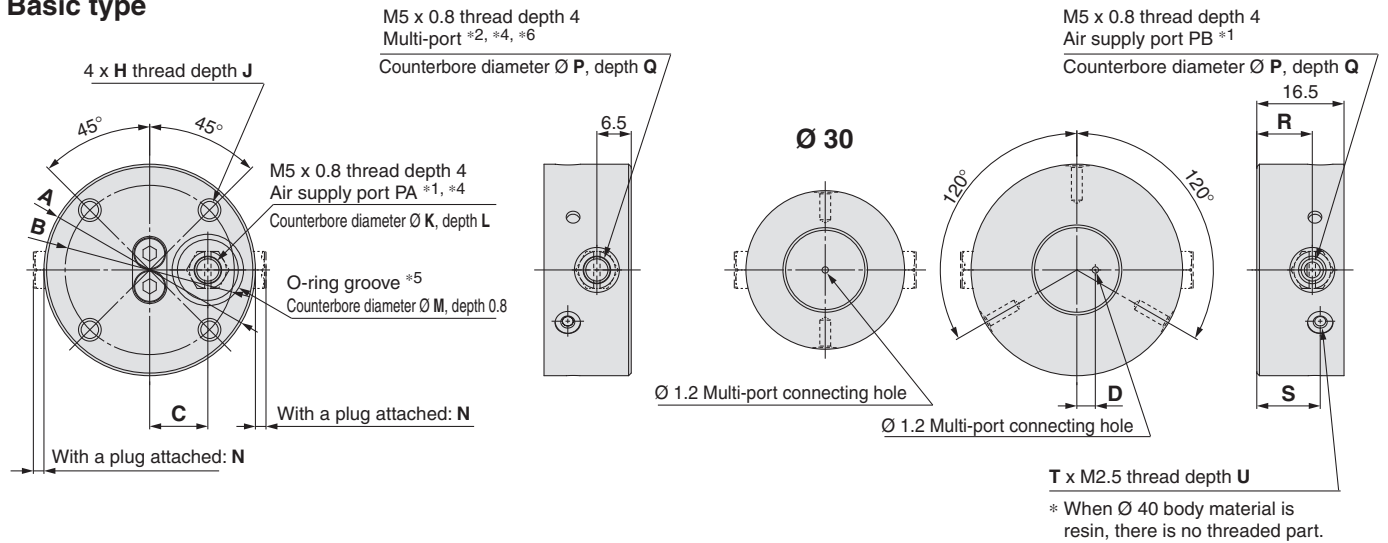

## With stopper

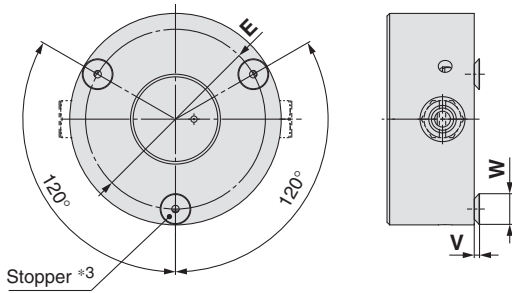

## With vibration suppression cover

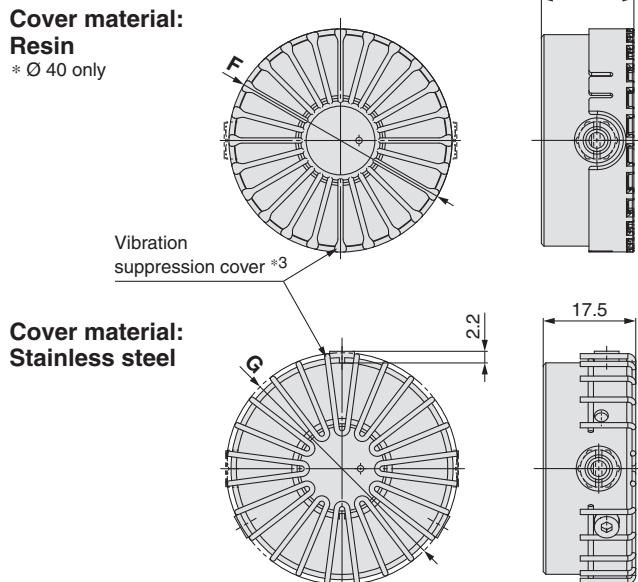

- \*1 Supply air to either air supply port PA or PB. Seal the unused ports with plugs.
- \*2 Seal the multi-port with a plug when not in use.
- \*3 The stopper and cover cannot be used together.
- \*4 The product is shipped with plugs in the air supply port PA and multi-port.  
After determining which port to use, it is recommended to apply adhesive to the threads of the two air supply ports and the multi-port.

- \*5 The O-ring is not included. If needed, it can be ordered separately or prepared by the customer.
- \*6 Use the multi-port as a sensor mounting or release port.
- \* For pressure sensor details, refer to the PSE 5 4 0 series in the **Web Catalogue** and the Operation Manual.
- \* The pressure sensor is shipped together with the product but does not come assembled.

## Dimensions

Model	Outer body dia.	Body material	[mm]																		Weight [g] <sup>*1</sup>			
			A	B	C	D	E	F	G	H	J	K	L	M	N	P	Q	R	S	T		U	V	W
ZNC	30	—	30	23	8.7	—	27	—	34	M3 x 0.5	6	8.5	3.3	10.5	2.2	8.5	0.8	11.3	11.8	2	4.2	0.8	2.8	27
		P																						17
		S																						77
	40	—	40	32	11	3.5	34	42.2	44	M4 x 0.7	8	11.5	3.6	13.5	2	8.5	1.0	10.5	12	3	5	1	5.8	48
		P																						30
		S																						139
60	—	60	47	21	10	54	—	64	M4 x 0.7	8	11.5	3.6	13.5	2	8.5	1.0	10.5	12	3	5	1	5.8	110	
	P																						67	
	S																						323	

\*1 The stopper, vibration suppression cover, and plug weights are not included.

## Dimensions: $\varnothing$ 80

### Basic type

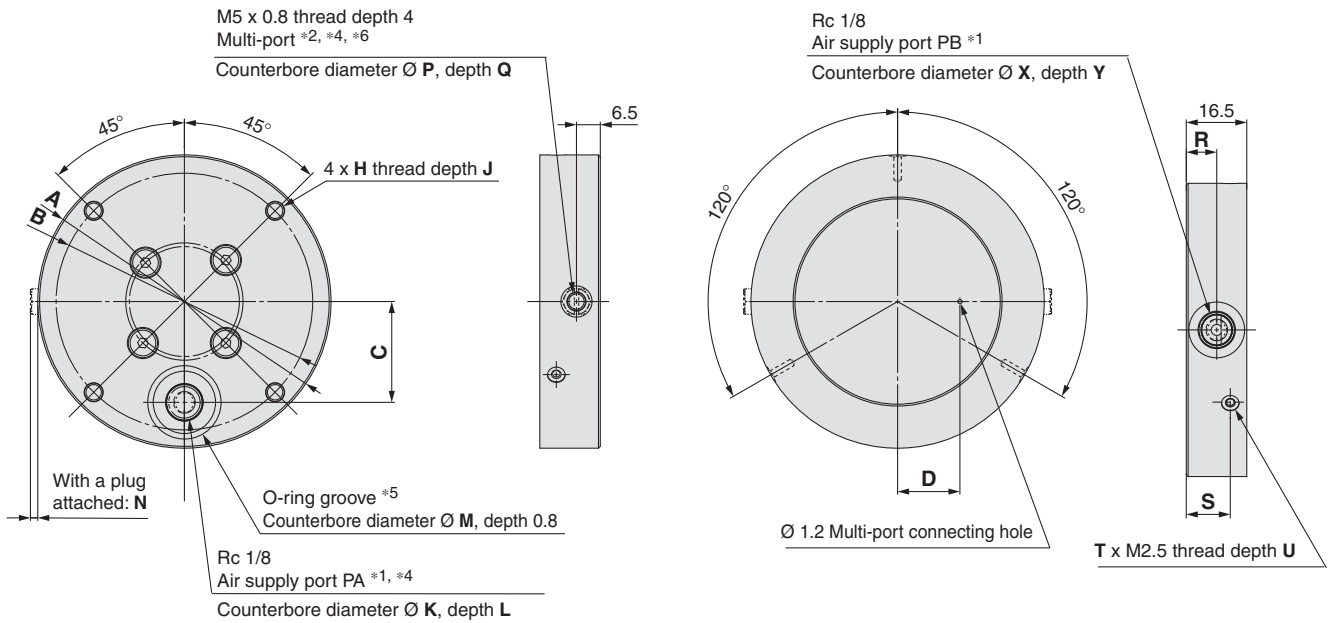

### With stopper

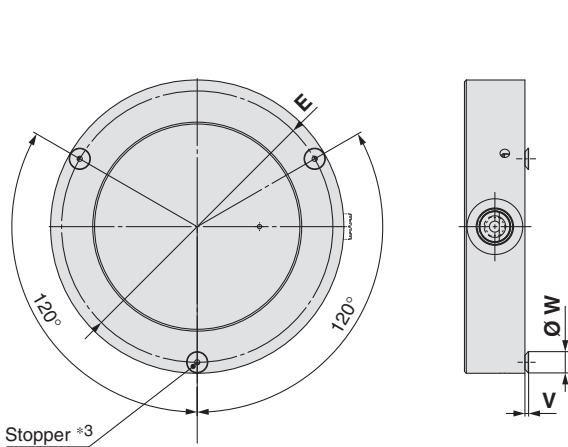

### With vibration suppression cover

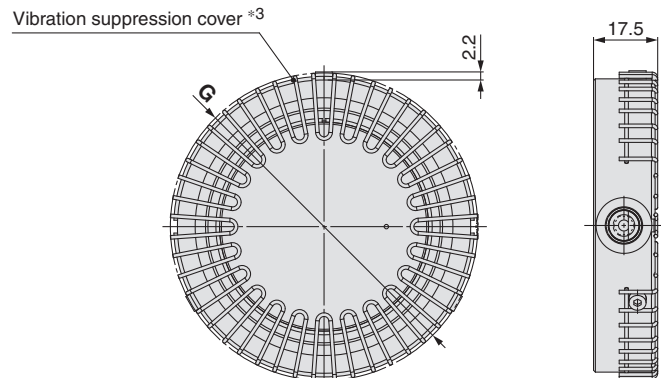

- \*1 Supply air to either air supply port PA or PB. Seal the unused ports with plugs.
- \*2 Seal the multi-port with a plug when not in use.
- \*3 The stopper and cover cannot be used together.
- \*4 The product is shipped with plugs in the air supply port PA and multi-port.  
After determining which port to use, it is recommended to apply adhesive to the threads of the two air supply ports and the multi-port.

- \*5 The O-ring is not included. If needed, it can be ordered separately or prepared by the customer.
- \*6 Use the multi-port as a sensor mounting or release port.
- \* For pressure sensor details, refer to the PSE 5 4 0 series in the **Web Catalogue** and the Operation Manual.
- \* The pressure sensor is shipped together with the product but does not come assembled.

### Dimensions

Model																				Weight [g] <sup>*1</sup>						
ZNC	Outer body dia.	Body material	A	B	C	D	E	F	G	H	J	K	L	M	N	P	Q	R	S	T	U	V	W	X	Y	
	80	—		80	70	27.5	17	74	—	84	M5 x 0.8	10	17	2.5	20	2	8.5	1.0	8.3	12	3	5	1	5.8	15.2	1.0
	P																									119
	S																									568

\*1 The stopper, vibration suppression cover, and plug weights are not included.



# ZNC Series

## Specific Product Precautions 1

Be sure to read this before handling the products.

### Design / Selection

- In the Bernoulli gripper, air flows between the suction surface and the workpiece when the workpiece is adsorbed. The workpiece is then gripped without direct contact, making it easy to slide sideways. Consider an external guide, etc., for safety design.**

The workpiece may fall due to the influence of external force or inertial force during workpiece transportation. This can cause injury or damage the equipment.

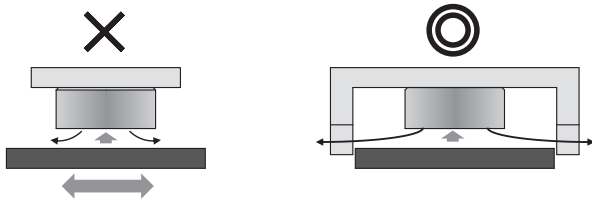

No restraining force in the horizontal direction

Restrain horizontal movement with a guide.

- The product performance of the Bernoulli gripper varies greatly depending on the type of workpiece. Please make your selection carefully.**

The lifting force changes depending on the shape, size, surface unevenness, breathability, flexibility, etc., of the workpiece.

- Select the Bernoulli gripper with sufficient margin for acceleration/deceleration, vibration, shock, and wind pressure during workpiece transportation.**

Ensure a safety factor for the allowable lifting force. The recommended value is 2 or more. If necessary, reduce external force and install a wind pressure prevention cover to design a safe application.

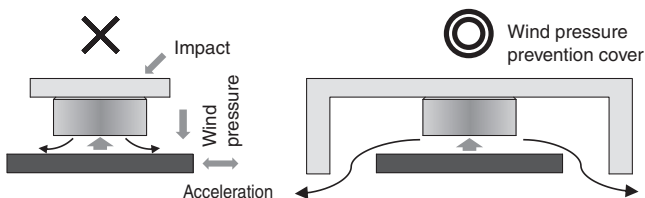

- When adjusting the distance between the Bernoulli gripper and the workpiece, design your application taking the performance characteristics for the distance into consideration.**

The lifting force changes depending on the distance from the workpiece.

- When adsorbing food, take sufficient safety measures. Additionally, please contact us in advance.**

- The product performance described in the catalogue is based on the condition that the workpiece is larger than the product suction surface, and the workpiece is smooth and non-breathable.**

If the workpiece is smaller than the product suction surface, the lifting force may be reduced or it may not be possible to lift. Please check with customer's equipment before use.

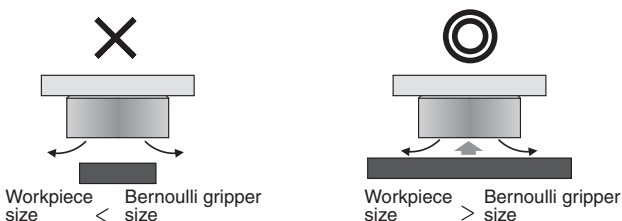

Workpiece size < Bernoulli gripper size

Workpiece size > Bernoulli gripper size

### Mounting

- Be careful not to drop or hit the product to avoid scratches and dents.**

Even slight deformation of the suction surface can decrease product performance.

- When installing the product, tighten it with an appropriate tightening torque.**

If excessive or insufficient tightening torque is applied, sealing failure or loose screws may result. Adhesive is recommended for screws.

#### Body Mounting

Model	Body material	Screw size	Max. screw-in depth [mm]	Tightening torque [N·m]
ZNC30	Aluminium	M3 x 0.5	6	0.63
ZNC30P	Resin			0.32
ZNC30S	Stainless steel			0.63
ZNC(40, 60)	Aluminium	M4 x 0.7	8	1.5
ZNC(40, 60)P	Resin			0.76
ZNC(40, 60)S	Stainless steel			1.5
ZNC80	Aluminium	M5 x 0.8	10	3
ZNC80P	Resin			1.5
ZNC80S	Stainless steel			3

- When installing the stainless steel vibration suppression cover, tighten it with the proper tightening torque.**

If excessive or insufficient tightening torque is applied, loose screws may result. Adhesive is recommended for screws.

#### Vibration Suppression Cover Mounting (Stainless steel type only)

Model	Body material	Screw size	Max. screw-in depth [mm]	Tightening torque [N·m]
ZNC30	Aluminium	M2.5 x 0.45	4.2	0.36
ZNC30P	Resin			0.18
ZNC30S	Stainless steel			0.36
ZNC(40, 60, 80)	Aluminium	M2.5 x 0.45	5	0.36
ZNC(40, 60, 80)P	Resin			0.18
ZNC(40, 60, 80)S	Stainless steel			0.36

- When installing tube fitting (supply port), pressure sensor (multi-port), and plugs, tighten them with an appropriate tightening torque. Retighten all bolts regularly.**

If excessive or insufficient tightening torque is applied, loose screws may result. Loose bolts may cause air leakage or falling of parts. Retighten them regularly and apply adhesive.

#### Supply Port

Model	Body material	Screw size	Max. screw-in depth [mm]	Tightening torque [N·m]
ZNC(30, 40, 60)	Aluminium	M5 x 0.8	4	1 to 1.5
ZNC(30, 40, 60)P	Resin			0.5 to 1
ZNC(30, 40, 60)S	Stainless steel			1 to 1.5
ZNC80	Aluminium	R1/8	—	7
ZNC80P	Resin			3
ZNC80S	Stainless steel			7



## ZNC Series

# Specific Product Precautions 2

Be sure to read this before handling the products.

### Mounting

5. When mounting the product directly without piping, smooth the mounting surface (Recommended surface roughness: Rz 25 or less) and use an appropriate O-ring. (The O-ring can be ordered separately or prepared by the customer.)

Installation on a mounting surface with a rough surface, scratches or dents, or mounting an unsuitable O-ring may cause sealing failure.

#### O-rings

Model	Single unit part no.	Size
ZNC30□	ZNCM-30DR	10.5 x 8.5 x 1
ZNC(40, 60)□	ZNCM-40DR	13.5 x 11.5 x 1
ZNC80□	ZNCM-80DR	20 x 18 x 1

\* Sales unit: 10 pcs.

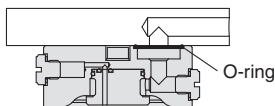

### Air Supply

1. Use compressed air and control the cleanliness.

Install an air filter, air dryer, or a mist separator. A system with a quality grade of No. C or higher in the air preparation equipment model selection guide of Best Pneumatics No. 6 is recommended.

### Handling

1. Depending on the use conditions, the workpiece may come into contact with the main body at the moment of suction even if it is a basic body type. If the product with stopper or with vibration suppression cover is used, it will come into contact with the workpiece.

2. The NBR stopper is not suitable for an ozone environment, so select silicone rubber.

Deterioration is accelerated in ozone environments such as in clean rooms, around ionizers or motor equipment.

3. The stopper and vibration suppression cover cannot be used together.

4. If a thin and soft workpiece is adsorbed, a high frequency sound may be produced. This generation of sound is due to the vibration of the workpiece, and is not a product abnormality.

Sound generation may be reduced by reducing the supply pressure or using the vibration suppression cover type.

5. Depending on the type of workpiece and usage conditions, the pressure sensor may not be able to detect the workpiece or the sensor value may differ.

The vacuum pressure changes depending on the type of workpiece and the conditions of use. Please verify the product with the actual machine before actual operation.

### Handling

6. When arranging the Bernoulli grippers, consider the position of the centre of gravity of the workpiece to maintain balance.

If the mounting position of the product and the position of the centre of gravity of the workpiece are misaligned, the rotational force acts due to the weight of the workpiece, which may cause it to come off.

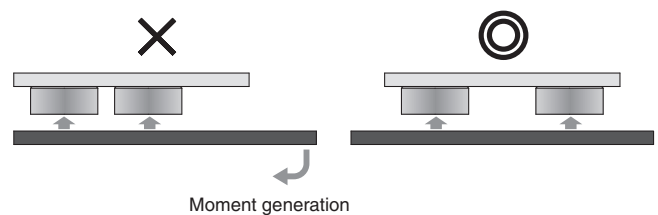

7. When installing the vibration suppression cover (synthetic resin), align the centre position of the product name plate and the SMC logo of the vibration suppressor.

If the mounting position is not correct, the vibration suppression cover may interfere with the fittings, etc., resulting in deterioration of product performance and damage to the cover.

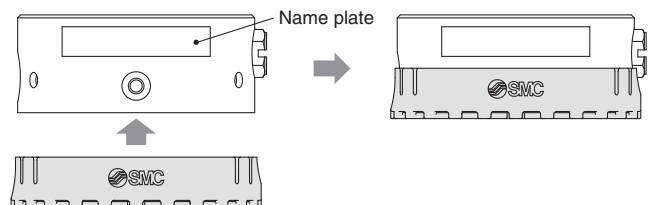

8. Stopper cannot be added afterward.

Since the body shape of the basic type and the stopper type are different, it is not possible to add a stopper to the basic type. If you order the stopper type and then remove the stopper to use it as the basic type, the lifting force will be lower than the basic type.

The vibration suppression cover can be added to the basic type afterward.

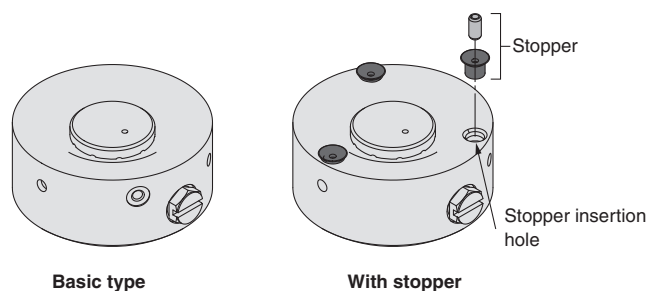

Example) For the ZNC40□/ZNC60□/ZNC80□



# ZNC Series

## Specific Product Precautions 2-1

Be sure to read this before handling the products.

### Handling

#### 9. Use fittings with the following specifications or recommended part numbers.

If the fitting dimensions are not compatible with the product, it may interfere with the product body. Therefore, such fittings cannot be used. For example, if the external dimensions of the fitting are too large, the following types of interference may occur. (See the precautions for each type of piping below.) And if the min. hole diameter of the air supply port fitting is too small, the product may fail to operate properly.

[Top ported] It may interfere with the product mounting bolt.

[Side ported] It may protrude from the product suction surface, interfering with the workpiece.

[Multi-port] It may protrude from the product mounting surface, interfering with the mounting portion.

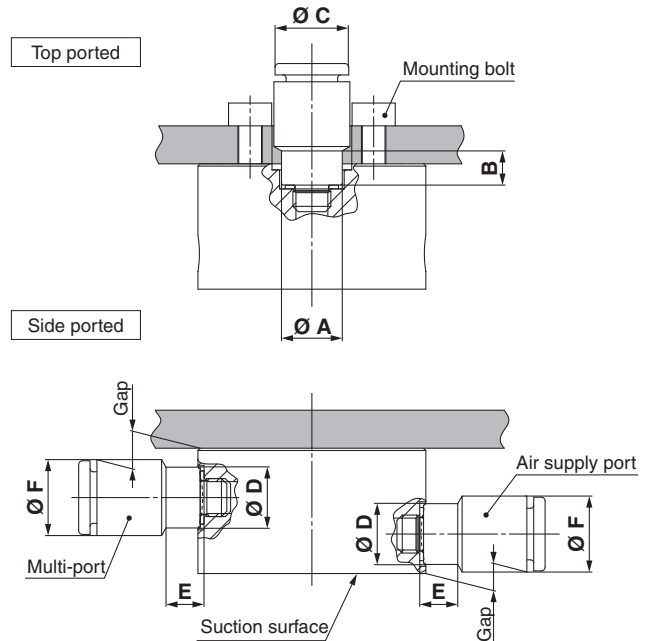

#### Specifications

[mm]

Model	Top ported			Side ported			Multi-port			Min. hole dia.
	A	B	C	D	E	F	G	H	J	
ZNC30	8.3 or less	3.6 or more	10 or less	8.3 or less	1 or more	10 or less	8.3 or less	1 or more	10 or less	2.5 or more
ZNC(40, 60)	11.3 or less	3.9 or more	11 or less	8.3 or less	1.2 or more	11 or less	8.3 or less	1.2 or more	11 or less	4.5 or more
ZNC80	16.8 or less	2.7 or more	—	15 or less	1.2 or more	16.2 or less	8.3 or less	1.2 or more	11 or less	4.5 or more

#### Recommended Part Numbers List

Series	Variations	Model	Top ported			Side ported			Multi-port	
			ZNC30	ZNC (40, 60)	ZNC80	ZNC30	ZNC (40, 60)	ZNC80	ZNC30	ZNC (40, 60, 80)
One-touch fittings	Male connector	KQ2H04-M5□	○	●	—	●	●	—	●	●
		KQ2H06-M5□	—	●	—	—	●	—	—	●
		KQ2H06-01□S	—	—	●	—	—	●	—	—
		KQ2H08-01□S	—	—	●	—	—	●	—	—
	Hexagon socket head male connector	KQ2S04-M5□	●	●	—	●	●	—	●	●
		KQ2S06-M5□	●	●	—	●	●	—	●	●
		KQ2S06-01□S	—	—	●	—	—	●	—	—
		KQ2S08-01□S	—	—	●	—	—	●	—	—
Metric size/ Uni One-touch fittings/ Gasket seal	Male connector	KQ2H06-U01□	—	—	●	—	—	●	—	
		KQ2H08-U01□	—	—	●	—	—	●	—	
	Hexagon socket head male connector	KQ2S06-U01□	—	—	●	—	—	●	—	
		KQ2S08-U01□	—	—	●	—	—	●	—	
Metric size/ One-touch fittings/ Face seal	Male connector	KQ2H06-01□P	—	—	●	—	—	●	—	
		KQ2H08-01□P	—	—	●	—	—	●	—	
	Hexagon socket head male connector	KQ2S06-01□P	—	—	●	—	—	●	—	
		KQ2S08-01□P	—	—	●	—	—	●	—	
Metal One-touch fittings	Male connector	KQB2H04-M5	—	●	—	—	●	—	●	
		KQB2H06-01S	—	—	●	—	—	●	—	
		KQB2H08-01S	—	—	●	—	—	●	—	
	Hexagon socket head male connector	KQB2S04-M5	○	●	—	●	●	—	●	●
		KQB2S06-01S	—	—	●	—	—	●	—	—
		KQB2S08-01S	—	—	●	—	—	●	—	—
Miniature fittings	Barb fitting for nylon tubing	M-5AN-6	○	●	—	●	●	—	●	
	Barb fitting for soft tubing	M-5AU-6	○	○	—	●	●	—	●	
	Hose nipple	M-5H-6	○	○	—	—	—	—	—	
Stainless steel One-touch fittings	Male connector	KQ2H04-M5G1	○	●	—	●	●	—	●	
		KQ2H06-M5G1	—	●	—	—	—	—	—	
		KQ2H06-01GS1	—	—	●	—	—	●	—	
		KQ2H08-01GS	—	—	●	—	—	●	—	
	Hexagon socket head male connector	KQ2S04-M5G1	●	●	—	●	●	—	●	
		KQ2S06-M5G1	●	●	—	—	—	—	—	
		KQ2S06-01GS1	—	—	●	—	—	●	—	
		KQ2S08-01GS	—	—	●	—	—	●	—	
One-touch fittings/ Stainless steel 316	Male connector	KQG2H04-M5	—	●	—	—	●	—	●	
		KQG2H06-01S	—	—	●	—	—	●	—	
		KQG2H08-01S	—	—	●	—	—	●	—	
	Hexagon socket head male connector	KQG2S04-M5	○	●	—	●	●	—	●	
		KQG2S06-01S	—	—	●	—	—	●	—	
		KQG2S08-01S	—	—	●	—	—	●	—	
Miniature fittings/ Stainless steel 316	Barb fitting for soft tubing	MS-5AU-6	○	●	—	●	●	—	●	
	Hose nipple	MS-5H-6	○	○	—	—	—	—	—	

\* ●: Applicable, ○: Extension fitting/M-5J required separately

\* □: A (Brass), N (Brass + Electroless nickel plating)



# ZNC Series

## Specific Product Precautions 3

Be sure to read this before handling the products.

### Handling

[Extension fitting/M-5J usage example]

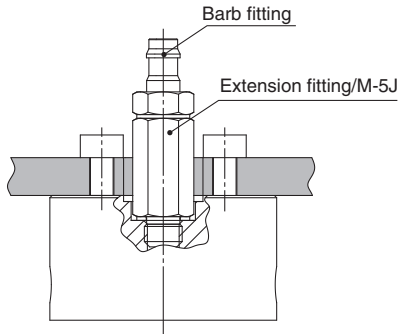

### 10. When multiple Bernoulli grippers are to be operated simultaneously, adjust the individual piping pressure of each gripper to the set pressure.

When the pressure is set just before a piping branch, the piping pressure in each pipe will decline, resulting in the product failing to operate properly.

The catalogue values are for when the connection between the pressure gauge and the Bernoulli gripper is as follows: Fitting min. hole diameter:  $\varnothing 2.5$  ( $\varnothing 30$ ,  $\varnothing 40$ ,  $\varnothing 60$ ), Fitting min. hole diameter:  $\varnothing 4.5$  ( $\varnothing 80$ ), Tubing size:  $\varnothing 6 \times \varnothing 4$ , Length: 500 mm

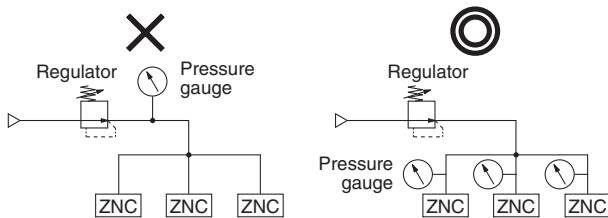

### Maintenance

#### 1. Do not disassemble or modify the body of the product.

If the disassembled and/or modified, the functions and performance may not be achieved and the product will not be warranted.

#### 2. In periodical inspections, check the following items and replace the parts if necessary.

- a) Scratches, gouges, abrasion, corrosion
- b) Air leakage (Retighten the fitting and plugs.)
- c) Twisting, crushing, and turning of connected tubes
- d) Hardening, deterioration, and softening of connected tubes
- e) Cracks, wear, and deformation of the stopper

#### 3. Replacement of the stopper

If the stopper is not mounted correctly, the product performance may deteriorate and the stopper may be damaged.

### Maintenance

#### ZNC30□

1

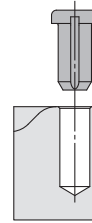

After removing the old stopper, insert the new stopper into the body.  
\*1 Apply alcohol for easier insertion.

2

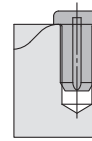

Push the stopper in until it reaches the position shown in the diagram.

#### ZNC40□/ZNC60□/ZNC80□

1

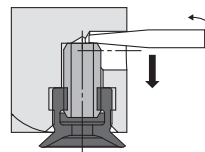

Use a precision screwdriver to push the spring pin out of the side hole in the body and remove the spring pin and stopper.

2

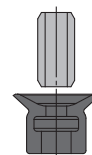

Insert the spring pin to a new stopper.

3

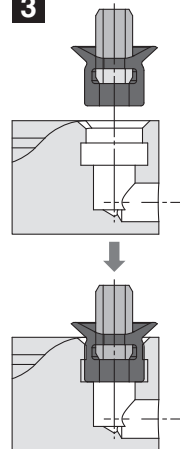

Insert the new stopper with a spring pin to the body.\*1  
\*1 Apply alcohol for easier insertion.

4

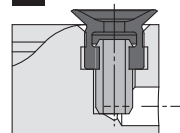

Insert the spring pin to the end.

# Bernoulli Gripper

Ø 20

Body size Ø 20 has been added.

For the adsorption transfer of thin cloths, films, printed circuit boards, etc.



## Lifting Force and Air Consumption

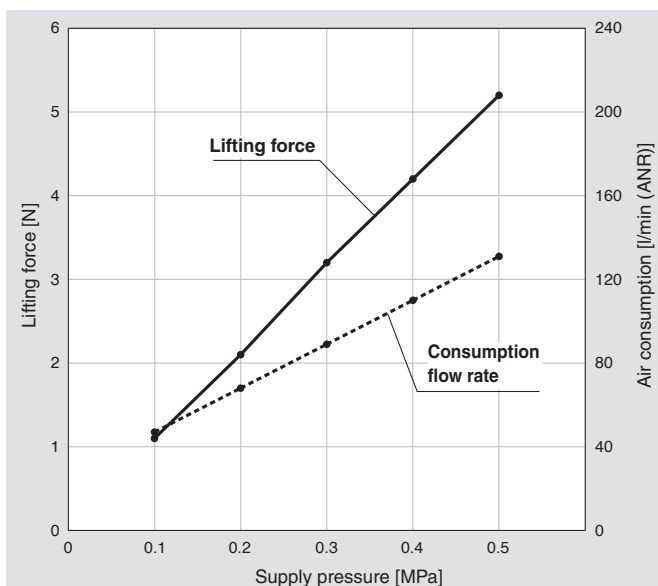

## Application Examples

For the adsorption of thin cloths

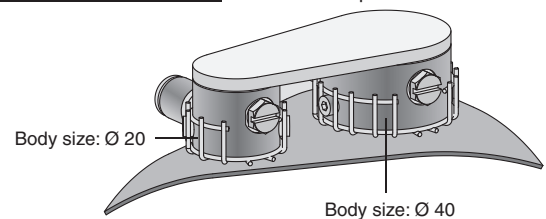

For the adsorption of plastic cases

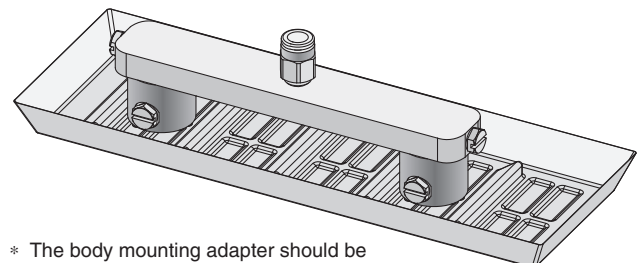

\* The body mounting adapter should be provided by the customer.

**ZNC20-X1**

**SMC**

21-EU772-UK

# ZNC20-X1

## How to Order

ZNC 20     -     - X1

1  
 2  
 3  
 4  
 5

### 1 Body size

20	Ø 20 mm
----	---------

### 2 Body material

—	Aluminium
P	Resin
S	Stainless steel

### 3 Mounting plate

—	Without mounting plate
---	------------------------

- \* The mounting plate is shipped together with the product but does not come assembled.
- \* The piping methods for types with and without a mounting plate are shown in Table 1.

### 4 Attachment

—	Basic type (Without attachment)	
PN	With stopper	NBR (Black)
PS		Silicone rubber (White)
VS	With vibration suppression cover	Stainless steel

- \* The stopper and vibration suppression cover cannot be used in combination.

### 5 Pressure sensor

—	None
S	With pressure sensor Part no.: PSE541-M5-X2

- \* The pressure sensor is shipped together with the product but does not come assembled.

Table (1) Piping

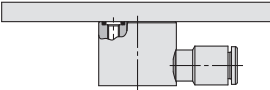
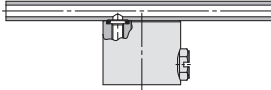
	Side ported	Body ported (Requires no piping)
Without mounting plate	 <p>Can be used by blocking the supply port on the top surface of the product with the mounting surface and connecting from the side port</p>	 <p>Can be used by connecting the piping inside the mounting surface with the supply port on the top surface of the product</p>

## Specifications

Model		ZNC20	
Lifting force [N]*1, *3		5.2	
Air consumption [l/min(ANR)]*2, *3		131	
Type		Bernoulli	
Fluid		Air	
Operating pressure		0.1 to 0.5 MPa	
Proof pressure		0.75 MPa	
Ambient and operating temperatures*4	Body material	Aluminium	-5 to 80 °C (0 to 50 °C)
		Resin	-5 to 40 °C (0 to 40 °C)
		Stainless steel	-5 to 80 °C (0 to 50 °C)
Grease		Grease-free	
Weight [g]*5	Body material	Aluminium	12
		Resin	7
		Stainless steel	34
Pressure sensor*6		PSE541-M5-X2 (Grease-free) Rated pressure range: 0 to -101 kPa	

- \*1 Lifting force of the basic type at the max. supply pressure  
Value when a flat, non-breathable workpiece is adsorbed
- \*2 Air consumption at the max. supply pressure
- \*3 The values are for when the connection is as follows: Fitting min. hole diameter: Ø 2.5, Tubing size: Ø 6 x Ø 4, Length: 500 mm
- \*4 No freezing or condensation. The values in ( ) are for models with a pressure sensor.
- \*5 The weight value is for the basic type without a mounting plate or plug. Add the mounting plate weight if needed. (Aluminium: 6.5 g, Stainless steel: 17.6 g)
- \*6 For pressure sensor details, refer to the PSE540 series in the **Web Catalogue** and the Operation Manual.

## Air Consumption

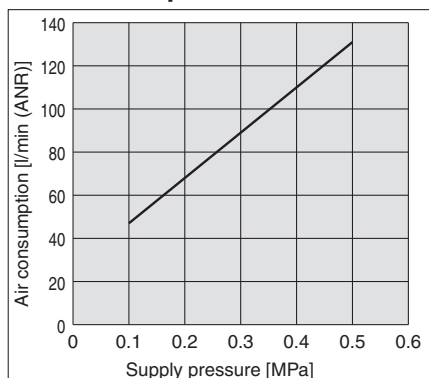

## Lifting Force

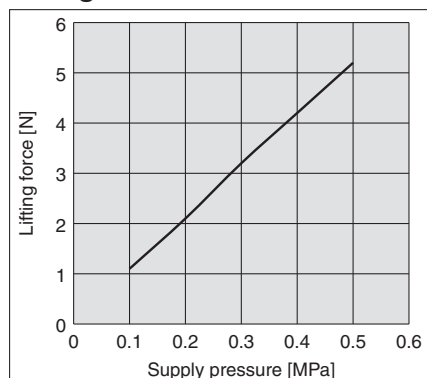

## Lifting Force–Distance from the Workpiece

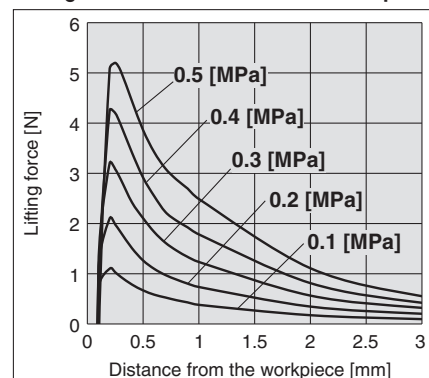

\* The lifting force changes depending on the shape, size, surface unevenness, breathability, flexibility, etc., of the workpiece. Use the values shown in the graphs above as a reference, and confirm using the actual machine.

\* For the lifting force when using a stopper or vibration suppression cover, use the following values as a guide for the distance from the workpiece. With stopper: 1 mm, With vibration suppression cover: 1.5 mm

## Dimensions

### Basic type/Without mounting plate

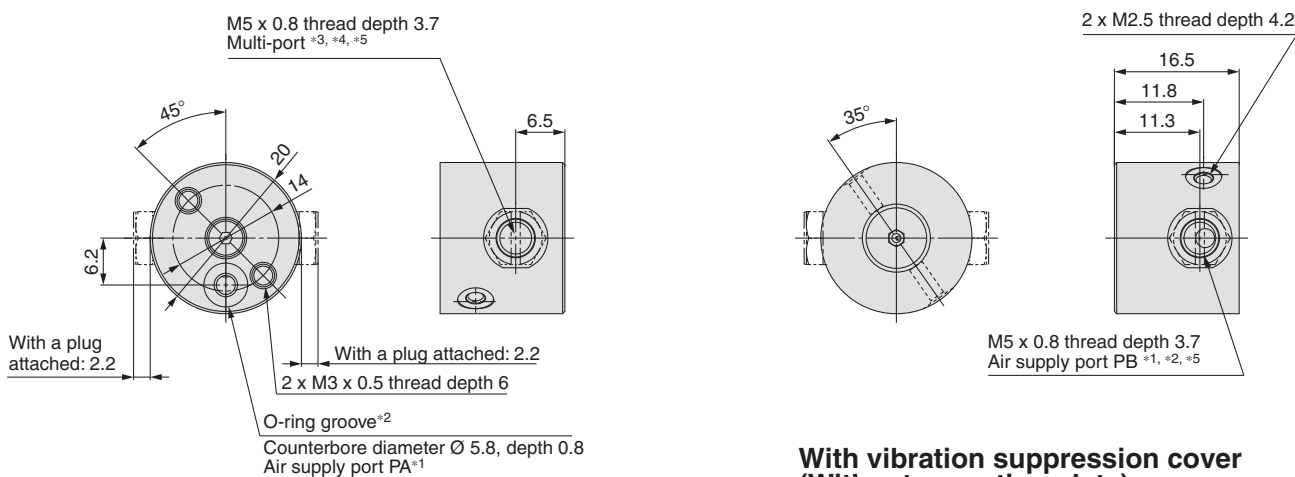

### With stopper (Without mounting plate)

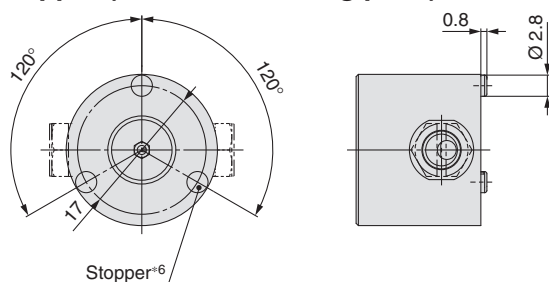

### With vibration suppression cover (Without mounting plate)

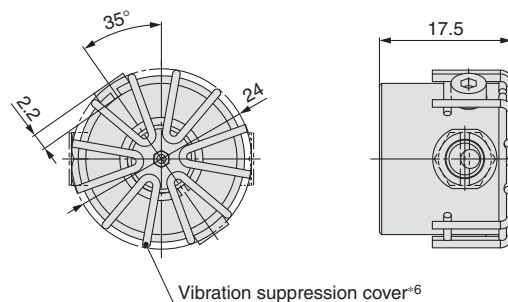

- \*1 Supply air to either air supply port PA or PB. Plug the unused air supply port.
- \*2 An O-ring (5.8 x 3.8 x 1) and a plug for the air supply port PB are included with the product. Be sure to attach the O-ring. For details on how to mount the product, refer to the "Specific Product Precautions."
- \*3 Use the multi-port as a sensor mounting or release port.
- \*4 Seal the multi-port with a plug when not in use.
- \*5 The product is shipped with a plug in the multi-port. After determining which port to use, it is recommended that adhesive be applied to the threads of the air supply port and the multi-port.

- \*6 The stopper and vibration suppression cover cannot be used in combination.
- \* The pressure sensor is shipped together with the product but does not come assembled.
- \* For pressure sensor details, refer to the PSE540 series in the **Web Catalogue** and the Operation Manual.

# ZNC20-X1

## Dimensions

### Basic type/With mounting plate

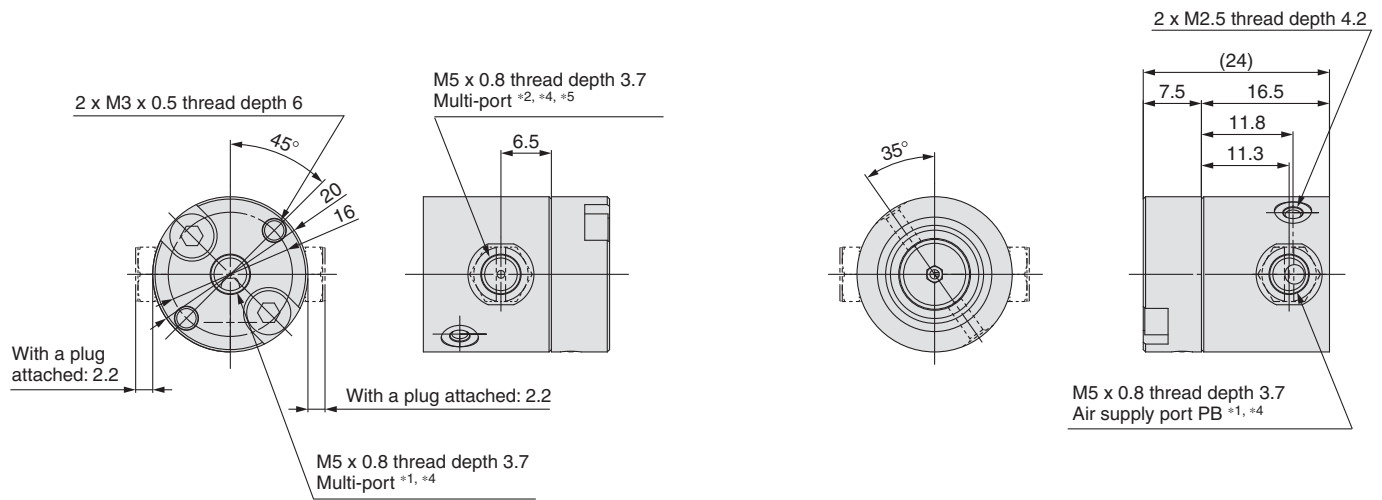

### With stopper (With mounting plate)

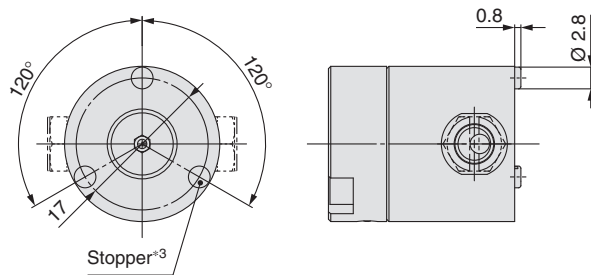

### With vibration suppression cover (With mounting plate)

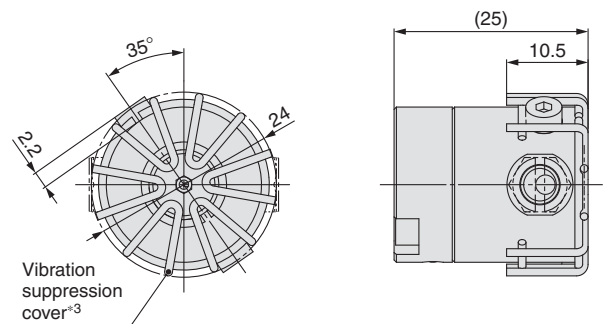

\*1 Be sure to change the mounting plate direction in accordance with whether air supply port PB or PC is used.

Also, be sure to mount the product in accordance with the mounting method described in the "Specific Product Precautions."

\*2 Seal the multi-port with a plug when not in use.

\*3 The stopper and cover cannot be used together.

\*4 The product is shipped with a plug in the multi-port. After determining which port to use, it is recommended that adhesive be applied to the threads of the air supply port and the multi-port.

\*5 Use the multi-port as a sensor mounting or release port.

\* The mounting plate comes with 1 O-ring (5.8 x 3.8 x 1), 1 plug for air supply port PB, and 2 mounting screws.

The mounting plate does not come assembled.

\* For pressure sensor details, refer to the PSE 5 4 0 series in the **Web Catalogue** and the Operation Manual.

\* The pressure sensor is shipped together with the product but does not come assembled.



# ZNC20-X1

## Specific Product Precautions 1

Be sure to read this before handling the products.

### Mounting

#### <Without Mounting Plate>

When mounting the product, be sure to attach the O-ring included with the product. Also, the mounting surface should be smooth (Recommended surface roughness: Rz 25 or less).

When using the product without piping (body ported), seal the side port with the attached plug.

When piping from the side, cover the supply port on the top of the product with the mounting surface.

Installation on a mounting surface with a rough surface, scratches or dents, or mounting an unsuitable O-ring may cause sealing failure.

#### Attached O-ring

Model	Size
ZNC20□	5.8 x 3.8 x 1

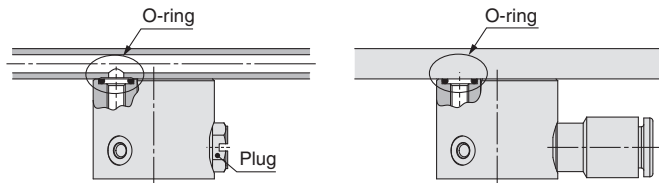

Requires no piping (Body ported)

Side ported

### Assembly

The mounting plate is shipped together with the product but does not come assembled. Please follow the assembly instructions below. In addition, be sure to change the mounting plate direction in accordance with the piping method.

#### Mounting method

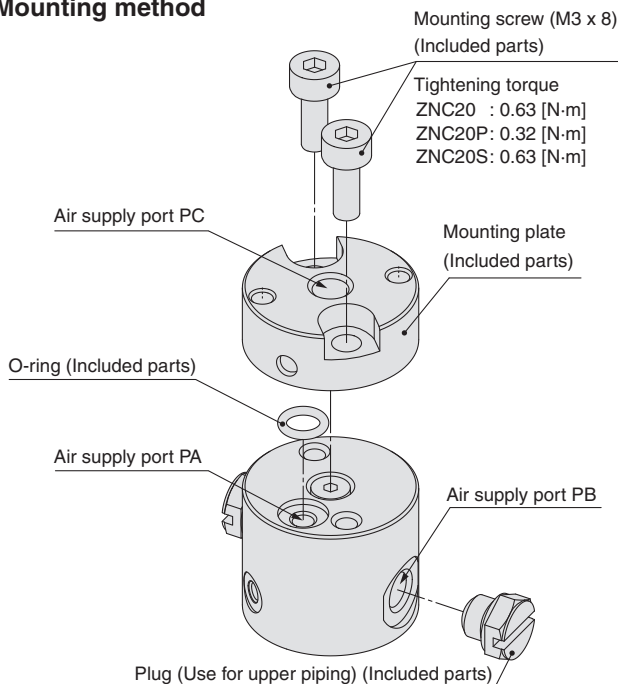

\*The drawing above shows the top ported type.

### Assembly

#### Mounting direction

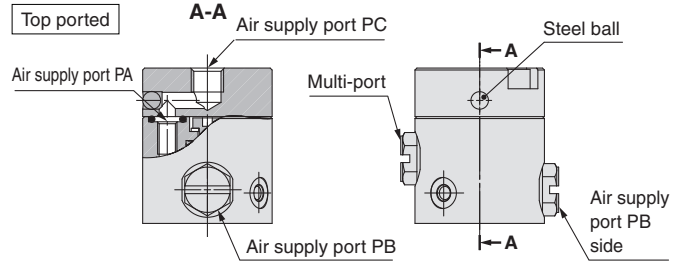

If the steel ball is visible the multi-port is on the left and the air supply port PB is on the right, the air supply port PA and the air supply port PB are interconnected.

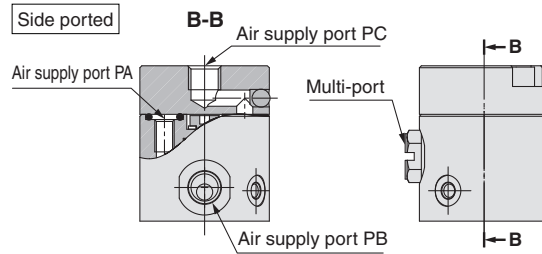

If the steel ball is not visible the multi-port is on the left and the air supply port PB is on the right, the air supply port PA is plugged.



# ZNC20-X1

## Specific Product Precautions 2

Be sure to read this before handling the products.

### Handling

Use fittings with the following specifications or recommended part numbers.

#### [Top ported]

If the fitting external dimensions are too large, it may interfere with the product mounting bolt.

#### [Side ported]

If the fitting dimensions are not compatible with the product, it may interfere with the product body. Therefore, such fittings cannot be used. If the fitting external dimensions are too large, it may protrude from the product mounting surface, interfering with the mounting portion, or it may protrude from the product suction surface, interfering with the workpiece.

Regardless of the piping direction, if the fitting min. hole diameter is too small, the product may fail to operate properly.

#### Specifications

[mm]

Model	Top ported	Side ported				Min. hole dia
	A	B	C	D		
ZNC20	10 or less	8.3 or less	1 or more	10 or less	2.5 or more	

Top ported

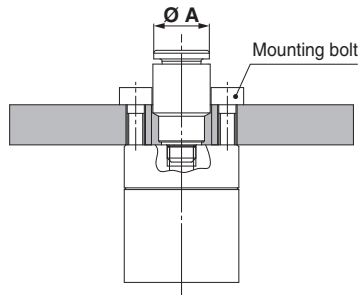

Side ported

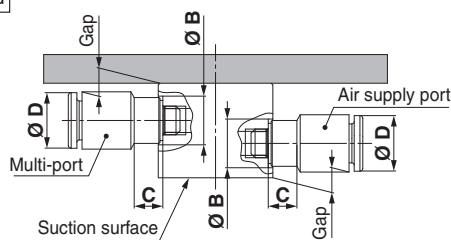

#### Recommended Part Numbers List

Series	Variations	Model	Top ported	Side ported
			ZNC20T	ZNC20
One-touch fittings	Male connector	KQ2H04-M5□	●	●
	Hexagon socket	KQ2S04-M5□	●	●
	head male connector	KQ2S06-M5□	●	●
Metal One-touch fittings	Hexagon socket head male connector	KQB2S04-M5	●	●
Miniature fittings	Barb fitting for nylon tubing	M-5AN-6	●	●
	Barb fitting for soft tubing	M-5AU-6	●	●
	Hose nipple	M-5H-6	●	×
Stainless steel One-touch fittings <small>Metal parts: Stainless steel 303</small>	Male connector	KQ2H04-M5G1	●	●
	Hexagon socket	KQ2S04-M5G1	●	●
	head male connector	KQ2S06-M5G1	●	×
Stainless steel 317 One-touch fittings	Hexagon socket head male connector	KQG2S04-M5	●	●
Miniature fittings/ Stainless steel 316	Barb fitting for soft tubing	MS-5AU-6	●	●
	Hose nipple	MS-5H-6	●	×

●: Applicable, ×: Not applicable

## Safety Instructions

These safety instructions are intended to prevent hazardous situations and/or equipment damage. These instructions indicate the level of potential hazard with the labels of “Caution,” “Warning” or “Danger.” They are all important notes for safety and must be followed in addition to International Standards (ISO/IEC)<sup>1)</sup>, and other safety regulations.

### Caution:

**Caution** indicates a hazard with a low level of risk which, if not avoided, could result in minor or moderate injury.

### Warning:

**Warning** indicates a hazard with a medium level of risk which, if not avoided, could result in death or serious injury.

### Danger:

**Danger** indicates a hazard with a high level of risk which, if not avoided, will result in death or serious injury.

- 1) ISO 4414: Pneumatic fluid power – General rules relating to systems.  
ISO 4413: Hydraulic fluid power – General rules relating to systems.  
IEC 60204-1: Safety of machinery – Electrical equipment of machines.  
(Part 1: General requirements)  
ISO 10218-1: Manipulating industrial robots - Safety.  
etc.

## Warning

### 1. The compatibility of the product is the responsibility of the person who designs the equipment or decides its specifications.

Since the product specified here is used under various operating conditions, its compatibility with specific equipment must be decided by the person who designs the equipment or decides its specifications based on necessary analysis and test results. The expected performance and safety assurance of the equipment will be the responsibility of the person who has determined its compatibility with the product. This person should also continuously review all specifications of the product referring to its latest catalogue information, with a view to giving due consideration to any possibility of equipment failure when configuring the equipment.

### 2. Only personnel with appropriate training should operate machinery and equipment.

The product specified here may become unsafe if handled incorrectly. The assembly, operation and maintenance of machines or equipment including our products must be performed by an operator who is appropriately trained and experienced.

### 3. Do not service or attempt to remove product and machinery/equipment until safety is confirmed.

1. The inspection and maintenance of machinery/equipment should only be performed after measures to prevent falling or runaway of the driven objects have been confirmed.
2. When the product is to be removed, confirm that the safety measures as mentioned above are implemented and the power from any appropriate source is cut, and read and understand the specific product precautions of all relevant products carefully.
3. Before machinery/equipment is restarted, take measures to prevent unexpected operation and malfunction.

### 4. Contact SMC beforehand and take special consideration of safety measures if the product is to be used in any of the following conditions.

1. Conditions and environments outside of the given specifications, or use outdoors or in a place exposed to direct sunlight.
2. Installation on equipment in conjunction with atomic energy, railways, air navigation, space, shipping, vehicles, military, medical treatment, combustion and recreation, or equipment in contact with food and beverages, emergency stop circuits, clutch and brake circuits in press applications, safety equipment or other applications unsuitable for the standard specifications described in the product catalogue.
3. An application which could have negative effects on people, property, or animals requiring special safety analysis.
4. Use in an interlock circuit, which requires the provision of double interlock for possible failure by using a mechanical protective function, and periodical checks to confirm proper operation.

## Caution

### 1. The product is provided for use in manufacturing industries.

The product herein described is basically provided for peaceful use in manufacturing industries.  
If considering using the product in other industries, consult SMC beforehand and exchange specifications or a contract if necessary.  
If anything is unclear, contact your nearest sales branch.

## Limited warranty and Disclaimer/Compliance Requirements

The product used is subject to the following “Limited warranty and Disclaimer” and “Compliance Requirements”. Read and accept them before using the product.

### Limited warranty and Disclaimer

1. The warranty period of the product is 1 year in service or 1.5 years after the product is delivered, whichever is first.<sup>2)</sup> Also, the product may have specified durability, running distance or replacement parts. Please consult your nearest sales branch.
  2. For any failure or damage reported within the warranty period which is clearly our responsibility, a replacement product or necessary parts will be provided. This limited warranty applies only to our product independently, and not to any other damage incurred due to the failure of the product.
  3. Prior to using SMC products, please read and understand the warranty terms and disclaimers noted in the specified catalogue for the particular products.
- 2) Vacuum pads are excluded from this 1 year warranty.  
A vacuum pad is a consumable part, so it is warranted for a year after it is delivered. Also, even within the warranty period, the wear of a product due to the use of the vacuum pad or failure due to the deterioration of rubber material are not covered by the limited warranty.

### Compliance Requirements

1. The use of SMC products with production equipment for the manufacture of weapons of mass destruction (WMD) or any other weapon is strictly prohibited.
2. The exports of SMC products or technology from one country to another are governed by the relevant security laws and regulations of the countries involved in the transaction. Prior to the shipment of a SMC product to another country, assure that all local rules governing that export are known and followed.

## Caution

### SMC products are not intended for use as instruments for legal metrology.

Measurement instruments that SMC manufactures or sells have not been qualified by type approval tests relevant to the metrology (measurement) laws of each country.  
Therefore, SMC products cannot be used for business or certification ordained by the metrology (measurement) laws of each country.

## Safety Instructions

Be sure to read “Handling Precautions for SMC Products” (M-E03-3) before using.