

3 Port Direct Operated Poppet Rubber Seal

Series VT317

Large Flow Capacity, yet Compact Size.

Dimensions(W X H X D).....45 X 89.5 X 45
VT317.....Nl/min 687.05 1/4

Suitable for Use in Vacuum Applications

-101.2kPa

(Vacuum Model: VT/VO317V)

1 Valve, 6 Functions.

(Universal Porting)

Selective porting can provide 6 valve functions, such as N.C. valve, N.O. valve, Divider valve, Selector valve etc.



JIS Symbol

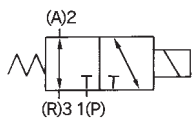

Model

	Single unit	Manifold style
Standard	VT317	VO317
Continuous duty	VT317E	VO317E
Vacuum	VT317V	VO317V

Manifold

Model	Applicable manifold style	Accessories
VO317□	Common or individual exhaust	O ring (P10-4 pcs.) Bolts (M4 X 20-2 pcs.)

Standard Specifications

Actuation	Direct operated 2 position single solenoid		
Fluid	Air		
Operating pressure range	0 to 0.9MPa		
Ambient and fluid temperature	0 (No condensation) to 50°C		
Response time ⁽¹⁾	30ms or less (0.5MPa)		
Max. operating frequency	10Hz		
Lubrication	Not required (If using a lubricant, use turbine oil Class 1 ISO VG32.)		
Manual override	Non-locking push style		
Mounting position	Free		
Impact/Vibration resistance ⁽²⁾	150/50m/s ²		
Enclosure	Dust proof		
Effective area mm ² (Nl/min) ⁽³⁾	12.6(687.05)		
Weight	0.29kgf		
Electrical entry	DIN connector		
Voltage	AC(50/60Hz)	100, 200, 24*, 48*, 110*, 220*, 240*	
	DC	24, 6*, 12*, 48*, 100*	
Allowable voltage	-15% to +10% of rated voltage		
Apparent power ⁽⁴⁾	AC	Inrush	19VA (50Hz), 16VA (60Hz)
		Holding	11VA (50Hz), 7VA (60Hz)
Power consumption ⁽⁴⁾	DC	Without light: 6W, With light: 6.3W	
Indicator light and surge suppressor	AC	ZNR (Varister), Neon lamp	
	DC	ZNR (Varister), LED (Neon lamp for 100V or more)	



* Option

Note 1) Based on dynamic performance test JIS B8374-1981. (Coil temperature 20C°, at rated voltage, without surge voltage suppressor.)

Note 2) Impact resistance: No malfunction resulted from the impact test using a drop impact tester. The test was performed on the axis and right angle directions of the main valve and armature, for both energized and de-energized states.

Vibration resistance: No malfunction occurred in a one-sweep test between 45 and 1000 Hz. Test was performed at both energized and de-energized states to the axis and right angle directions of the main valve and armature. (Value in the initial stage.)

Note 3) This is the value for single valve. For manifold type, refer to "Manifold Specifications" on p.2.5-12.

Note 4) At rated voltage.

Option Specifications

Continuous Duty Style: VT317E

Exclusive use of VT317E is recommended for continuous duty with long time loading.

⚠ Caution

1. This model is for continuous duty, not for high cycle rates. But even in low cycle rates, if energizing the valve more than once a day, consult SMC.
2. Energizing solenoid should be done at least once in 30 days.

Vacuum Style: VT317V

This vacuum model has less air leakage than the standard model under low pressure. It is recommended for vacuum applications.

⚠ Caution

1. Since this valve has slight air leakage, it can not be used for vacuum holding (including positive pressure holding) in the pressure container.

Specifications different from standard are as follows.

Operating pressure range | -101.2kPa to 0.1MPa

⚠ Precautions

Be sure to read before handling.
Refer to p.0-33 to 0-36 for Safety Instruction and common precautions.

⚠ Caution

1. A bleed port for the main valve is located at the bottom of the solenoid valve. Since blocking it causes malfunction, do not block it.
 - * When mounted on the metallic surface, bleeding is normally done from the bleed port through the bleed groove, but when mounted on an elastic surface, elastic shape deformation may close the port.
2. Make sure that dust and/or other foreign materials should not enter the valve from the unused port such as exhaust port. Also, since there is a bleed port for the armature in the manual override, do not allow accumulation of dust and/or other foreign materials to block bleed port.

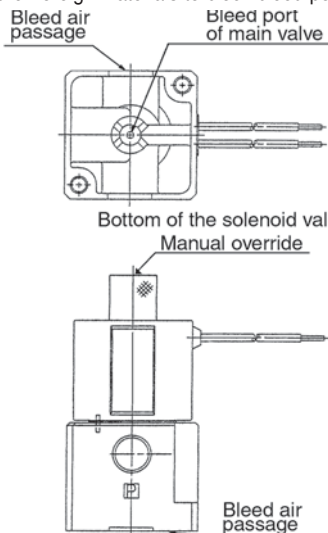

How to Calculate Flow Rate

Refer to p.0-36 for the calculation of flow rate.

How to order

E **V** **T** 317 **1** **G** **02** **-Q**

• Body style

T	Body ported
0	For manifold

• Ordering source area code

Code	areas
-	Japan, Asia Australia
E	Europe
N	North America

• Valve specification

-	Standard
E*	Continuous duty
V*	Vacuum

*Option

• Voltage

1	100V AC (50/60 Hz)
2	200V AC (50/60 Hz)
3*	110V AC (50/60 Hz)
4*	220V AC (50/60 Hz)
5	24V DC
6*	12V DC
7*	240V AC (50/60 Hz)
9*	less than 250 VCA and 50 VDC

*Option  Contact SMC for other voltages (9)

• Electrical entry

D	DIN connector (with connector)
DO	DIN connector (without connector)

• Thread

-	Rc (PT)
F	G (PF)
N	NPT
T	NPTF

• Port size

-	Without port (For manifold)
02	1/4 (8A)

• Indicator light and surge voltage suppressor



Symbol	Electrical entry	D
-	-	-
S	●	●
Z	●	●

* DOZ, DOS are not available.



S: With surge voltage suppressor
 Z: With indicator light and surge voltage suppressor

* As to the case of rated voltage [Others (9)], please contact SMC.

 Protective class class I (Mark: )

VT317

Construction

De-energized

Energized

Operation principles
<De-energized>
 Spool valve ② is pushed upward by the return spring ③, port [P] is closed, and port [A] and port [R] are opened.

<Energized>
 When an electric current is applied to the molded coil ④, the armature ⑤ is attracted to the pole ⑥, and through the push rod ⑦, it pushes down the spool valve ②. Then port [P] and port [A] are connected. At this time, there will be gaps between the armature ⑤ and the pole ⑥, but the armature will be magnetically attracted to the pole ⑥.

Component Parts

No.	Description	Material	Notes
①	Body	Aluminum die cast	Color: Platinum silver
②	Spool valve	Aluminum, NBR	

⚠ Caution

Change of Electrical Entry Angle

- Series VT317 can change electrical entry angle. (4 positions)
- How to change:
 Loosen the nut ①, remove the coil ② from the body assembly ③, place the positioning pin ④ at the required place, put back the coil ② to its place, and tighten sufficiently with lock nut ①.

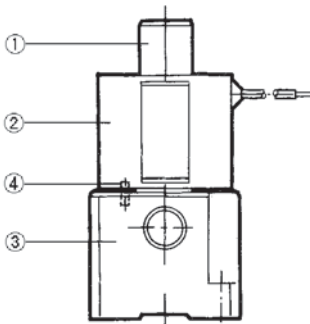

Indicator light and surge voltage suppressor

- DC
DIN connector/Conduit terminal
 - With surge voltage suppressor (S)
- With indicator light and surge suppressor (Z)
 48V DC or less 100V DC

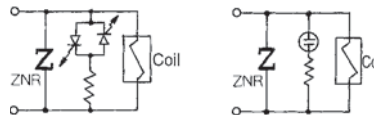
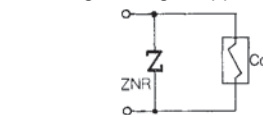

Wiring

DIN connector is connected inside as in the figure below. Connect to the corresponding power supply.

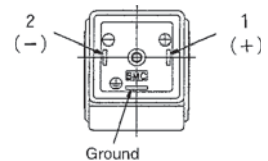

- Applicable cable O.D.
 $\phi 6$ to $\phi 12$
- Note) For those with an external measurement of $\phi 9$ to $\phi 12$, remove the inner portion of the ground gasket before using.
- Applicable crimping terminal
 The maximum size for the round terminal is 1.25mm²-3.5 and for the Y terminal is 1.25mm²-4.

Dimensions (mm)

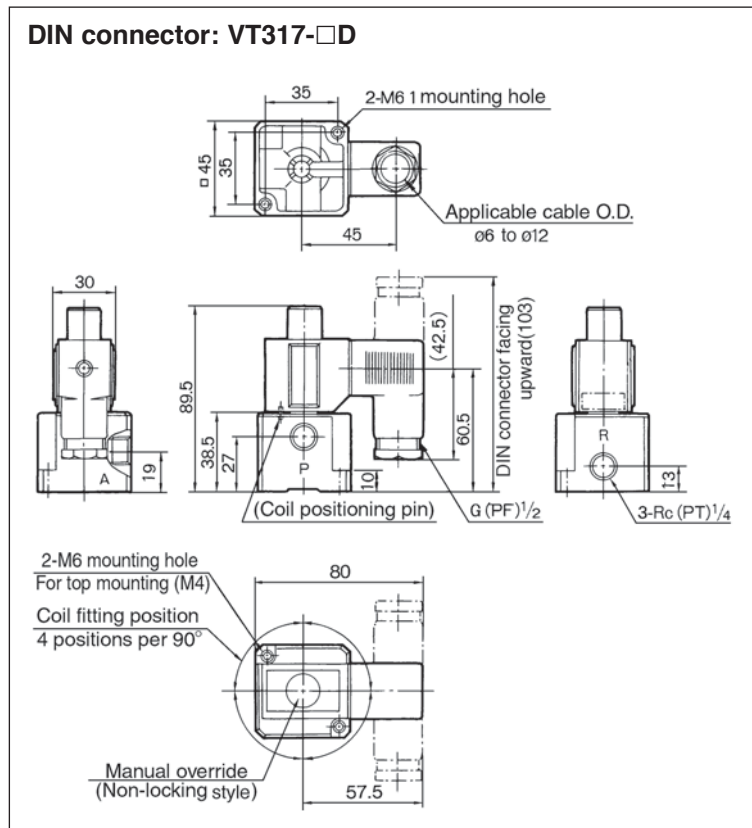

Series VT317 Manifold

VT307 manifold is B mount style and available both as a common exhaust and individual exhaust model.

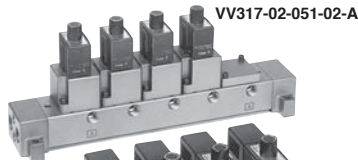

Common exhaust

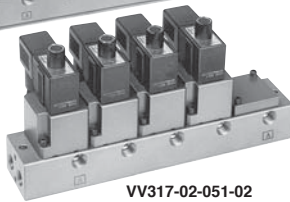

VV317-02-051-02

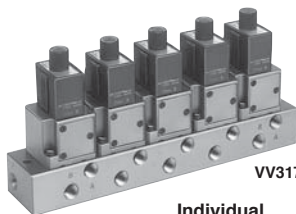

Individual exhaust

VV317-02-053-02

⚠ Precautions

Be sure to read before handling.
Refer to p.0-33 to 0-36 for Safety Instruction and common precautions.

Mounting

⚠ Caution

- Each valve is fixed to the manifold base with two M4 mounting screws. Tighten the screws evenly when re-mounting. Tightening torque of the mounting screw (M4): 1.4Nm
- For mounting, tighten M4 or equivalent screws evenly into the mounting holes of the manifold base.

Ordering source area code

Code	areas
-	Japan, Asia Australia
E	Europe
N	North America

Specifications

Manifold style		B Mount			
Max. number of stations		20 (1)			
Applicable solenoid valve		VO317□-□□□ (3)-Q			
Code	Exhaust	Port location (piping)/Port size			Effective area (mm ²) (Nl/min)
		Style	P	A	
1	Common (2)	Base (side)	Base (side)	Base (side)	10 (549.64)
		1/4 (3/8)	1/4	1/4 (3/8)	
3	Individual	Base (side)	Base (side)	Base (side)	
		1/4	1/4	1/4	

- ⦿ Note 1) If operating with 3 valves or more, apply supply pressure to both of the P ports of the manifold. The common exhaust style should exhaust from both of the R ports.
- Note 2) In the case of common exhaust type, R and P ports size can be 3/8 by using a mounting adaptor.
- Note 3) Can also be applied to Series VVT320 manifold.

⚠ Caution

Changing from NC to NO

Universal porting permits convertibility NC/NO by a simple 180-degree rotation.

Exhaust	Valve	N.C.	N.O.
Common exhaust			

- ⦿ *) Changing from NC to NO
This product is delivered as N.C. valve.
If N.O. valve is needed, remove mounting screws of the required valve and turn the valve at 180 degrees. (Make sure that there are O rings fixed on 4 positions of the valve surface.) Then, tighten the mounting screws to fix the valve to the manifold base.

Option

Description	Part No.
Blank plate (With screw, O ring)	PVT317-53-1A
Mounting adaptor (with screw)	DXT010-37-4 (for common exhaust)

How to Order Manifold Base

E **VV317-02-05** **1-02** **□** **-A**

Base style
: 1/4

⦿ **VT317 Manifold**
* Specify both the manifold base model and the valve and blank plate to be manifolded to the base.
Ordering Example:
VV317-02-051-02-A.....1 pc.
(5-station manifold base)
VO317-1D-Q.....4 pcs.
PVT317-53-1A.....1 pc.
(Blank plate)

Option
A Mounting adaptor*
*Common exhaust style only

Thread
- Rc (PT)
F G (PF)
N NPT
T NPTF

A port size (base piping) 1/4

Piping

Code	Passage		Piping
	P	R	A
1	Common	Common	Side
3	Common	Individual	Side

Stations

02	2 stations
:	:
20	20 (Max)

⚠ Protective class class I (Mark: ⊕)

Common Exhaust/Dimensions (Interchangeable with VVT320 for mounting.)

Without mounting adaptor/VV317-02-□1-02

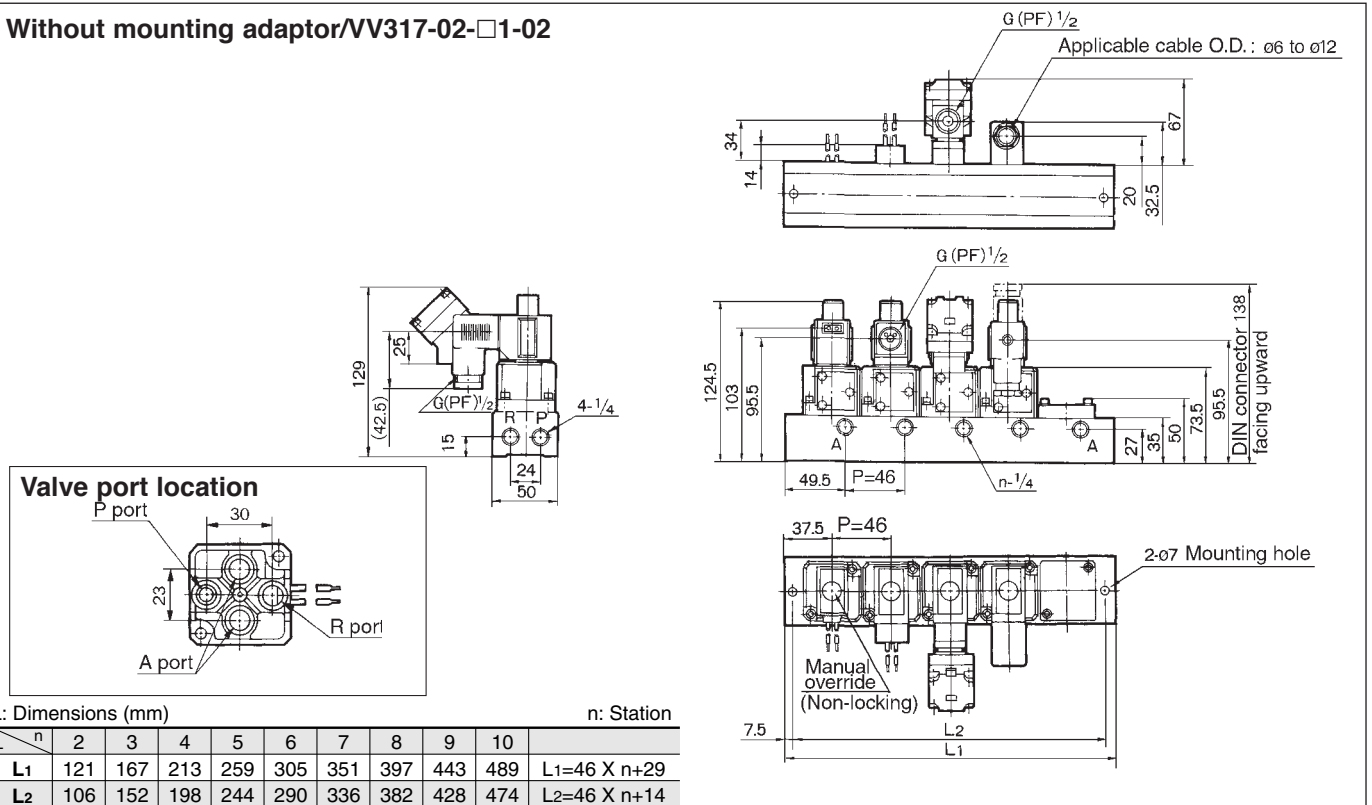

With mounting adaptor/VV317-02-□1-02-A

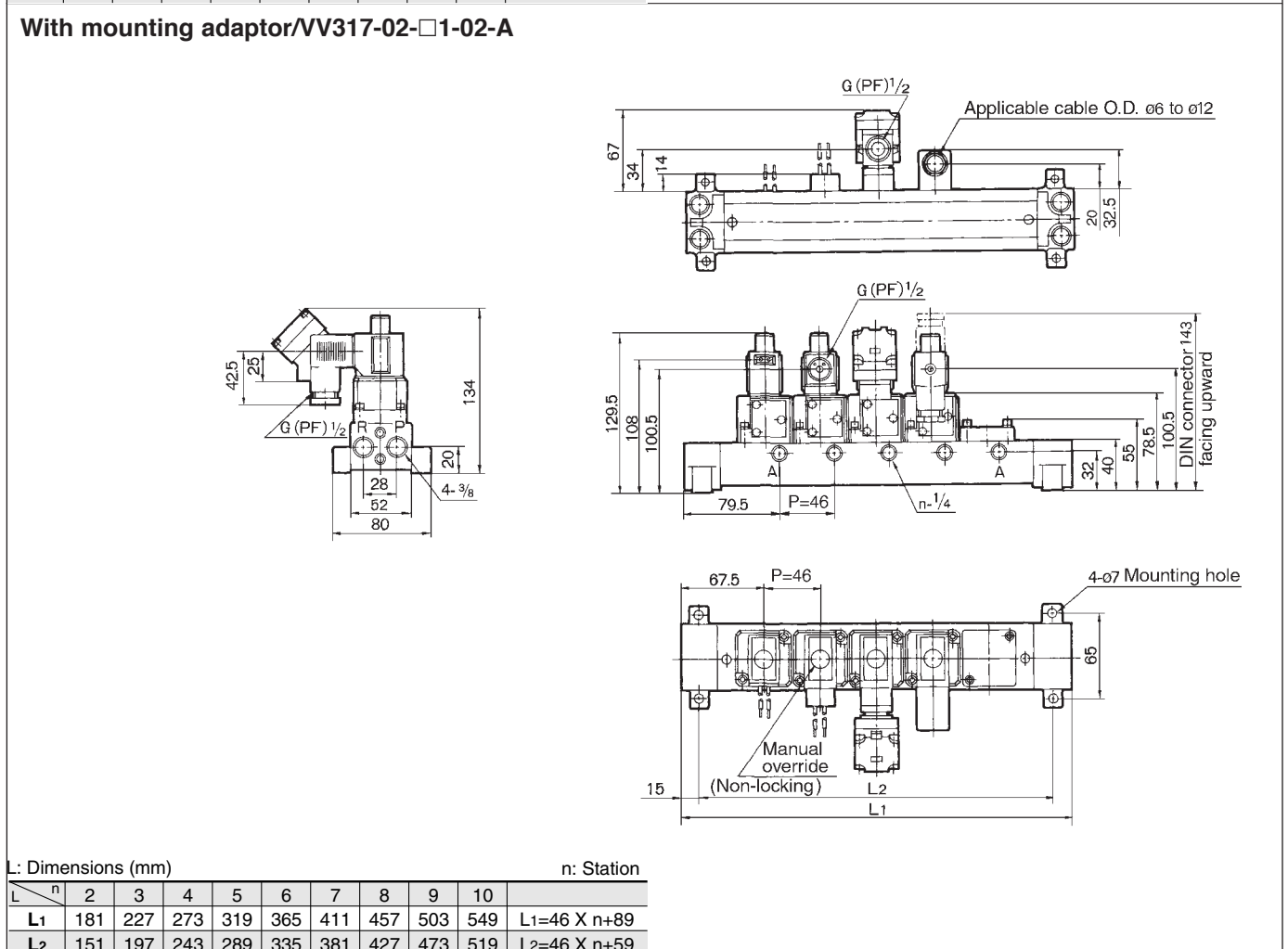

VT317

Individual Exhaust/Dimensions (mm)

Without mounting adaptor/VV317-02-□3-02

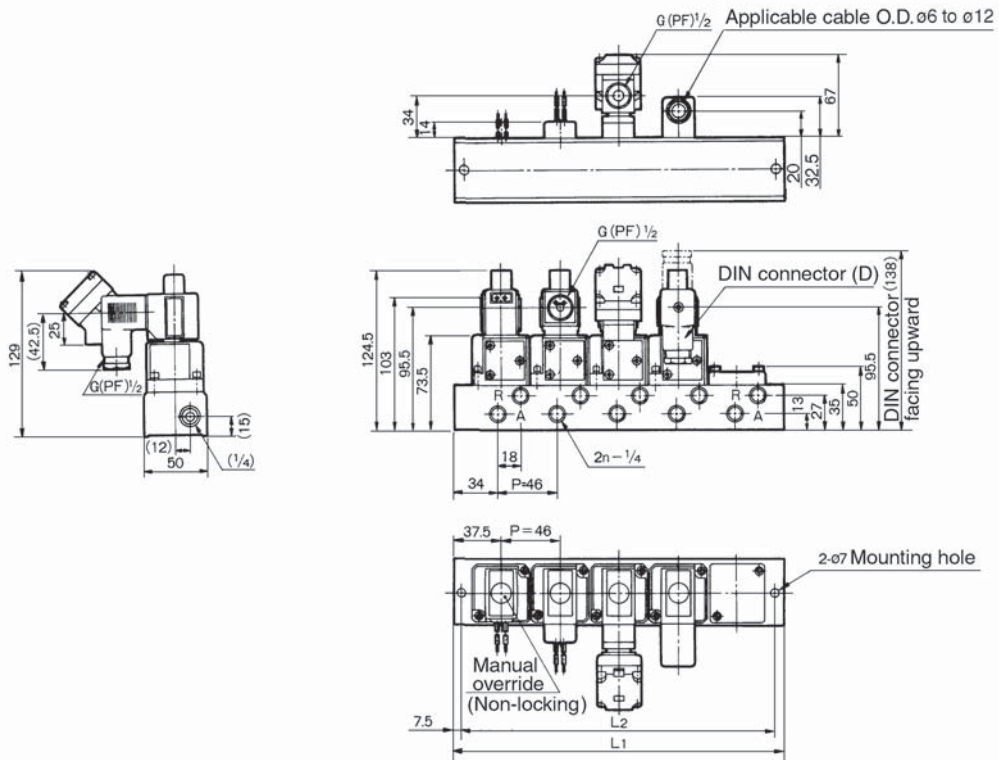

L: Dimensions (mm)

n: Station

L \ n	2	3	4	5	6	7	8	9	10	
L ₁	121	167	213	259	305	351	397	443	489	L ₁ =46 X n+29
L ₂	106	152	198	244	290	336	382	428	474	L ₂ =46 X n+14

3 Port Poppet Rubber Seal Series VT325

Compact yet provides a large valve capacity
Dimensions (W X H X D) ...55 X 118 X 53
VT325: Nl/min 1472.25...3/8

A single valve with 6 valve functions (Universal porting style)

Six valve functions can be attained by selecting the piping ports. (Enabling the NC valve, NO valve, divider valve, selector valve, etc. to be used as desired.)

Can be used for vacuum applications

-101.2kPa
(Vacuum style: VT/VO325V)



VT325-□□D

Specifications

Actuation	Direct operated 2 position single solenoid
Fluid	Air
Operating pressure range	0 to 1.0MPa
Ambient and fluid temperature	5 to 50°C
Max. operating frequency	5Hz
Response time (1)	30ms or less (at 0.5MPa)
Effective area (Nl/min) (2)	27mm ² (1472.25: 3/8), 25mm ² (1374.1: 1/4)
Lubrication	Not required (Use turbine oil class 1 ISO VG32 for lubrication)
Manual override	Non-locking push
Impact/Vibration resistance (3)	150/50 m/s ²
Enclosure	Dust proof



Note 1) As per JIS B8374-1981 (Coil temperature 20°C, at rated voltage, without surge suppressor)

Note 2) Value for valve unit. It varies in case of manifold. Refer to p.2.5-18 for manifold specifications.

Note 3) Impact resistance: No malfunction from test using drop impact tester, to axis and right angle directions of main valve and armature, each one time when energized and de-energized. (Initial value)

Vibration resistance: No malfunction from test with 45 to 1000Hz 1 sweep, to axis and right angle directions of main valve and armature, each one time when energized and de-energized. (Initial value)

Solenoid Specifications

Electrical entry		DIN connector	
Coil rated voltage		100 and 200 VAC, (50/60Hz), 24VDC	
Allowable voltage		-15% to +10% of rated voltage	
Apparent power (3)	AC	Inrush	50Hz 75VA 60Hz 60VA
		Holding	50Hz 27VA 60Hz 17VA
	DC	12W	
	Power consumption (3)		12W



Note 3) At rated voltage

Model

Model	Port size	Piping	Weight
VT325-02□□D	1/4	Body ported	0.55kg
VT325-03□□D	3/8		

Manifold

Model	Applicable manifold	Accessories
VO325-00□□	B mount common exhaust style	Seal (DXT083-13-1), Bolt (DXT083-19-1, 2 pcs.)

Symbol

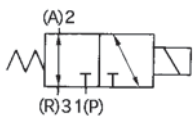

How to Order

E VT325 **□□** **02** **□□** **1** **G** **□□** **-Q**

For manifold: VO

Valve specifications

Nil	Standard
V*	Vacuum

*Option

Port size

02	1/4
03	3/8
00	Without connection port (for manifold)

Thread

-	Rc (PT)
F	G (PF)
N	NPT
T	NPTF

Coil rated voltage

1	100V AC 50/60Hz
2	200V AC 50/60Hz
3*	110V AC 50/60Hz
4*	220V AC 50/60Hz
5	24V DC
6*	12V DC
7*	240V AC 50/60Hz
9*	Others

*Option
Contact SMC for other voltages (9)

Surge voltage suppressor

-	None
S	With surge suppressor (AC: Can be attached to Grommet, Conduit, Conduit terminal styles DC: Can be attached to Grommet type, Conduit styles)

Electrical entry

D	DIN terminal (with connector)
DO	DIN terminal (without connector)
DLO	DIN terminal with light (with connector)
DL**	DIN terminal without light (without connector)

**Contact SMC for coil rated voltage (*option).

Ordering source area code

Code	areas
-	Japan, Asia Australia
E	Europe
N	North America

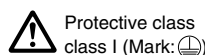

Option Specifications

1. For vacuum

Pressure range | -101.2kPa to 0.1MPa

In contrast to the standard product, this vacuum specification valve has less air leakage at low pressures, a feature that should be taken into consideration when using this valve for vacuum applications.

⚠ Caution

1) Because this valve leaks air, it cannot be used for maintaining a vacuum (or pressure) in a pressure vessel.

2. Manual override with lock

1) Using a screwdriver, push the manual override button that is located in the head portion of the solenoid valve in order to directly push the spool valve downward, thus causing the valve to switch.

2) With the button remaining pushed down, turn it approximately 90° clockwise or counterclockwise to maintain the manual override locked state.

3) To revert to the original state, keep the button pushed down and turn it approximately 90° clockwise or counterclockwise.

⚠ Precaution

Be sure to read before handling.
Refer to p.0-33 to 0-36 for Safety Instructions and common precautions.

⚠ Caution

1. The bottom of the solenoid valve has a breather hole for the main valve. Take proper measures to prevent this hole from being blocked as this will lead to a malfunction.

* Ordinarily, when the solenoid valve is mounted on a metal surface, it can breathe through the breather hole, via the breather groove. However, in particular, if the surface to be mounted is made of rubber, the rubber could deform and block the hole.

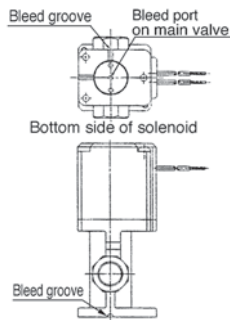

2. Take proper measures to prevent dust or foreign matter from entering through unused ports. The grommet portion contains a breather hole for the core. Take proper measures to prevent dust or foreign matter from accumulating in this area.

Construction

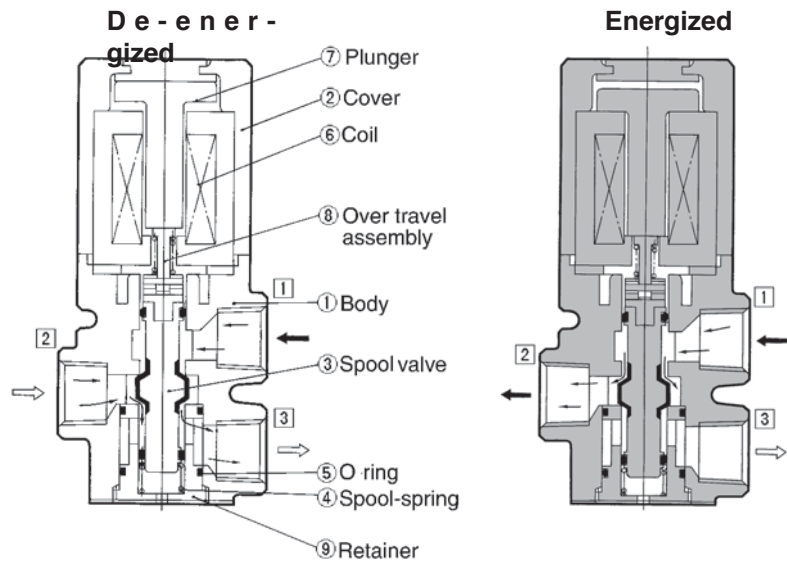

Operation principles

<De-energized>

The spool ③ is pushed upward by the force of the spring ④ and the air passage between port ② and port ③ is opened and port ① is blocked.

Air flow direction: ① ↔ Block, ② ↔ ③

<Energized>

When the coil ⑥ is energized the plunger ⑦ is pulled down depressing the spool ③ via the overtravel assembly ⑧ and the air passage between port ① and port ② is opened and port ③ is blocked.

Air flow direction: ① ↔ ②, ③ ↔ Block

Parts list

No.	Description	Material	Notes
①	Body	ADC	Platinum silver
②	Cover	ADC	Platinum silver
③	Spool valve	Aluminum, NBR	

How to Use DIN Connector

1. How to wire

- Loosen the fix screw and pull off the connector from the pin plug.
- Make sure to pull out the retaining screw before inserting a screwdriver into the groove at the lower portion of the terminal board. Then, push the screwdriver up to separate the terminal board and the terminal cover.
- Following the wiring procedure, properly connect the wires to the specified terminals.
- As a rule, wires are connected to the terminals using crimp-style terminals. Therefore, select crimp-style terminals that do not overstrain the terminal hardware.

Wiring figure

Single sole



Terminal block view (★)
 Connect wires to terminals 1 and 2.
 Terminal 3 is not used.

Pin plug

2. Change of electrical entry

Once the terminal cover is separated from the terminal block, it can be rotated in any direction (4 directions, each 90°) to change the orientation of the electrical entry.

Flow rate

Refer to p.0-36 for flow rate calculation.

3. Caution

To insert the connector into the pin plug or to pull it out, do so as vertically as possible, without tilting.

4. Applicable cable

Cord external: $\phi 6$ to $\phi 12$

Note: For those with external measurements of $\phi 9$ to $\phi 12$, remove the inner portion of the ground gasket before use.

5. Applicable crimp-style terminals

The maximum size for the round terminal is 1.25mm²-3.5 and for the Y terminal is 1.25mm²-4.

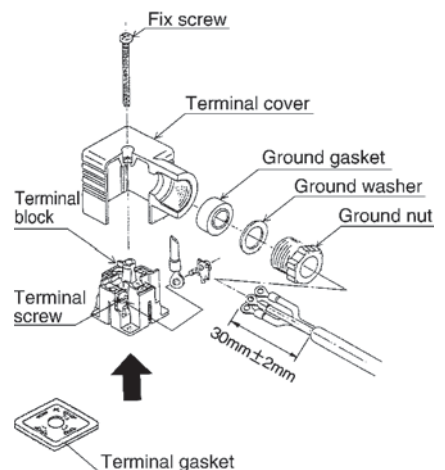

Dimensions (mm)

DIN terminal (D)

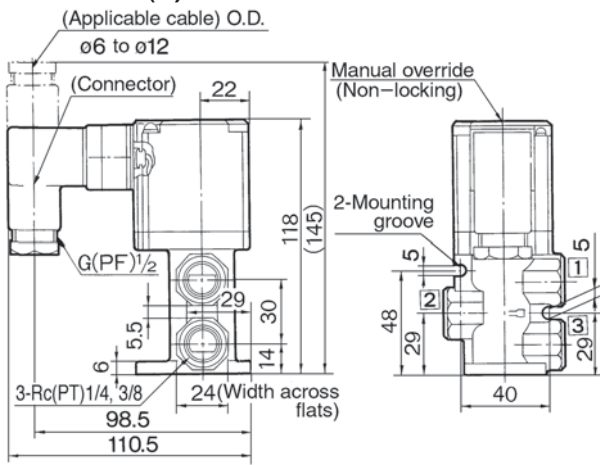

With locking manual override

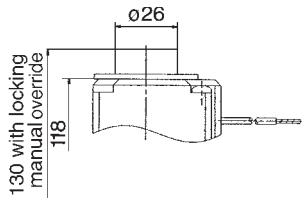

Series VT325 Manifold

VT325 Series Manifold Model has a B-mount style with common exhaust.

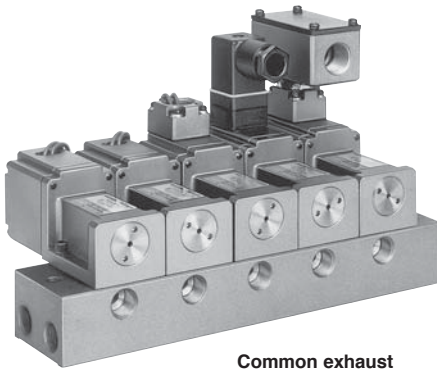

Common exhaust

⚠ Caution

How to Change from NC to

NO valves are assembled as NC valves at the time of shipment. By removing the two retaining screws from the desired valves, and rotating each valve body 180° and reassembling it on the manifold base, it is possible to reassemble an NO valve. (When doing so, make sure that a gasket is attached to the mounting surface of the valve.) Properly tighten the screws. The tightening torque of the retaining screws is 3Nm.

Manifold Specifications

Manifold				B-mount			
Max. number of stations				17 ⁽¹⁾			
Applicable solenoid valve				VO325-00□□-Q			
Exhaust port style	Port location/Port size			Piping			Effective area (mm ²) (Nl/min)
	P	A	R	P	A	R	
Common	Base 1/4, 3/8	Base 1/4, 3/8	Base 1/4, 3/8	Side	Side/ Bottom	Side	19 (1030.58)
Option				Blank plate (packing w/screw)			DXT083-21A

Note 1) If there are more than 4 stations, supply air from both P ports and exhaust from both R ports.

How to Order Manifold Base

E VVT34 **0** **05** **1** - [] []

Porting

Symbol	P	A	R
0	Side	Side	Side
1	Side	Bottom	Side

Port size

Symbol	Port size
02	1/4
03	3/8

Thread

	Rc (PT)
F	G (PF)
N	NPT
T	NPTF

Ordering source area code

Code	areas
-	Japan, Asia Australia
E	Europe
N	North America

Exhaust

1	Common
---	--------

Stations

02	2 stations
⋮	⋮
17	17(Max.)

* Specify the part numbers for the valve(s), blank plate, and manifold base
<Example>
VVT340-051.....1 pc.
VO325-001D-Q.....4 pcs.
DXT083-21-A.....1 pc.

⚠ Protective class class I (Mark: Ⓢ)

Dimensions

Common Exhaust

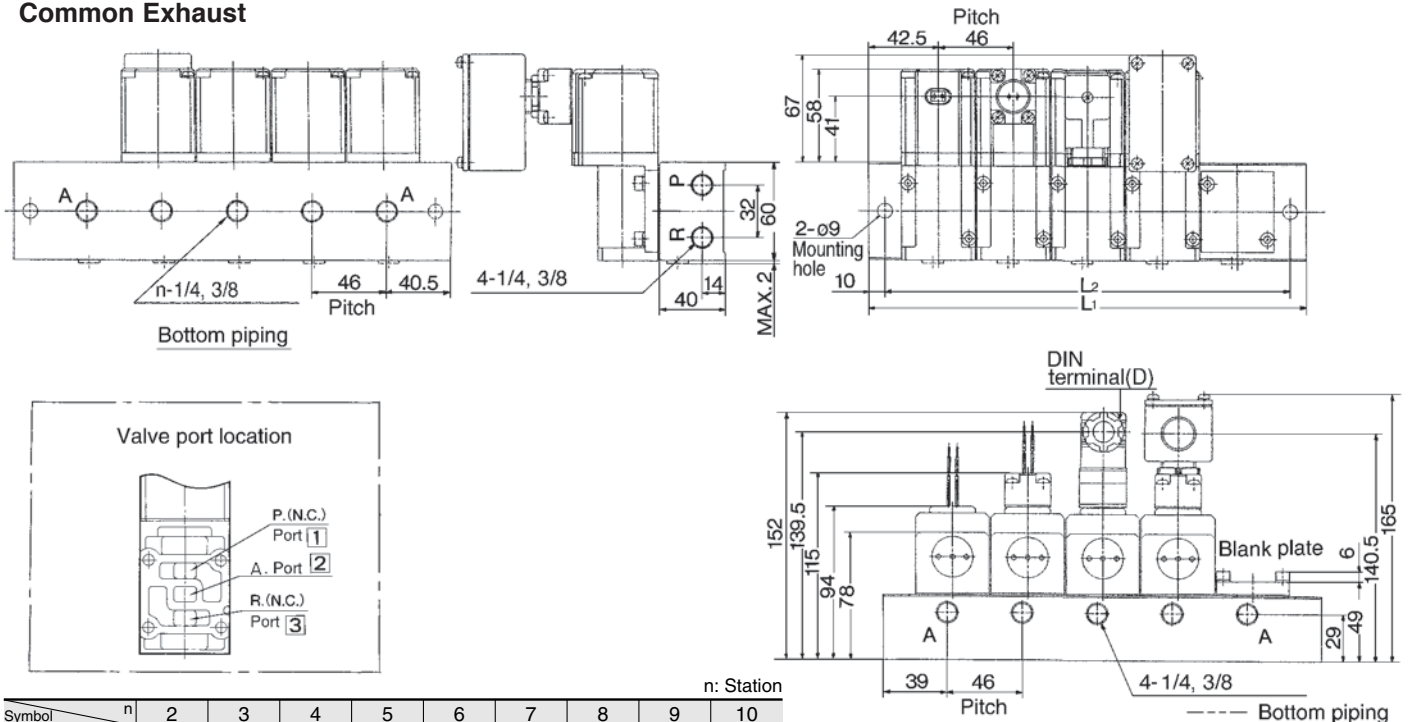

Symbol	n	2	3	4	5	6	7	8	9	10
L1		131	177	223	269	315	361	407	453	499
L2		111	157	203	249	295	341	387	433	479

Equation: L1=46n+39, L2=46n+19

