



# Stainless Steel Cylinder *Series CJ5-S/series CG5-S*

ø10, ø16    ø20, ø25, ø32, ø40, ø50, ø63, ø80, ø100



For use in environments with water splashing such as food processing machines

# Stainless Steel Cylinder

## Series **CJ5-S**/Series **CG5-S**

ø10, ø16

ø20, ø25, ø32, ø40, ø50, ø63, ø80, ø100

Uses grease for food processing machines  
(Approved by NSF-H1)

Special scraper (standard)  
prevents water from entering  
the cylinder.

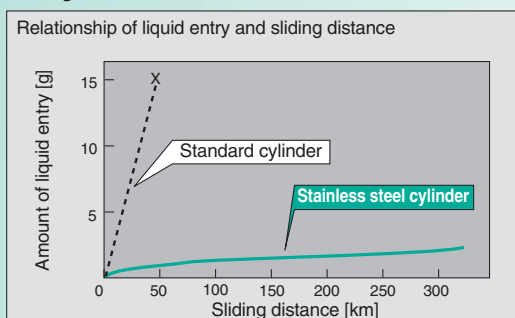

### Conditions

Working fluid ..... Air  
Pressure ..... 0.5 MPa  
Liquid ..... Water-soluble coolant  
Piston speed ..... 200 mm/sec (60 cpm)

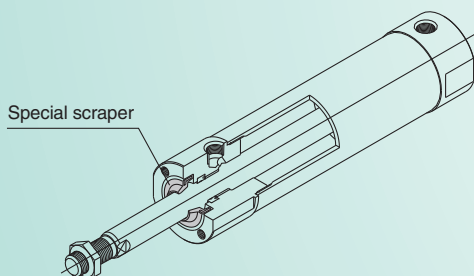
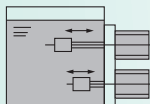

Two types of seal material  
**NBR** or **FKM** can be selected to  
accommodate the application.

(Nitrile rubber) (Fluoro rubber)

Can be disassembled (Series **CG5-S ø20 to 40**)  
Replacement of seals promotes an extended service life.  
(Before disassembly, be sure to see the section regarding  
maintenance under "Specific Product Precautions" on page 18.)

This product cannot be used in the food zone. Refer to the Product Specific Precautions (page 18) for details.

# Applicable for use in environments with water splashing such as food processing, etc.

All stainless steel specification (external parts)

**Stainless steel (SUS304)** is used for external metal parts. Corrosion resistance is improved even in environments with exposure to water.



Exterior configuration reduces residual liquid

- Electropolishing of mounting bracket surfaces makes them smoother to prevent build-up of liquids and foreign matter.
- Plugs are provided for unused mounting threads (Series CG5-S) to prevent residue build-up in the threads.

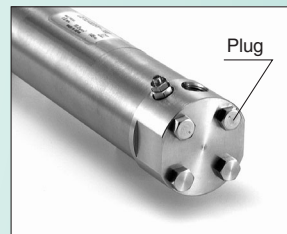

## Series Variations

Series	Seal materials	Bore sizes [mm]											
		10	16	20	25	32	40	50	63	80	100		
CJ5-S	NBR	●	●										
CG5-S	FKM			●	●	●	●	●	●	●	●	●	●

# Stainless Steel Cylinder

# Series CJ5-S

Ø10, Ø16

## How to Order

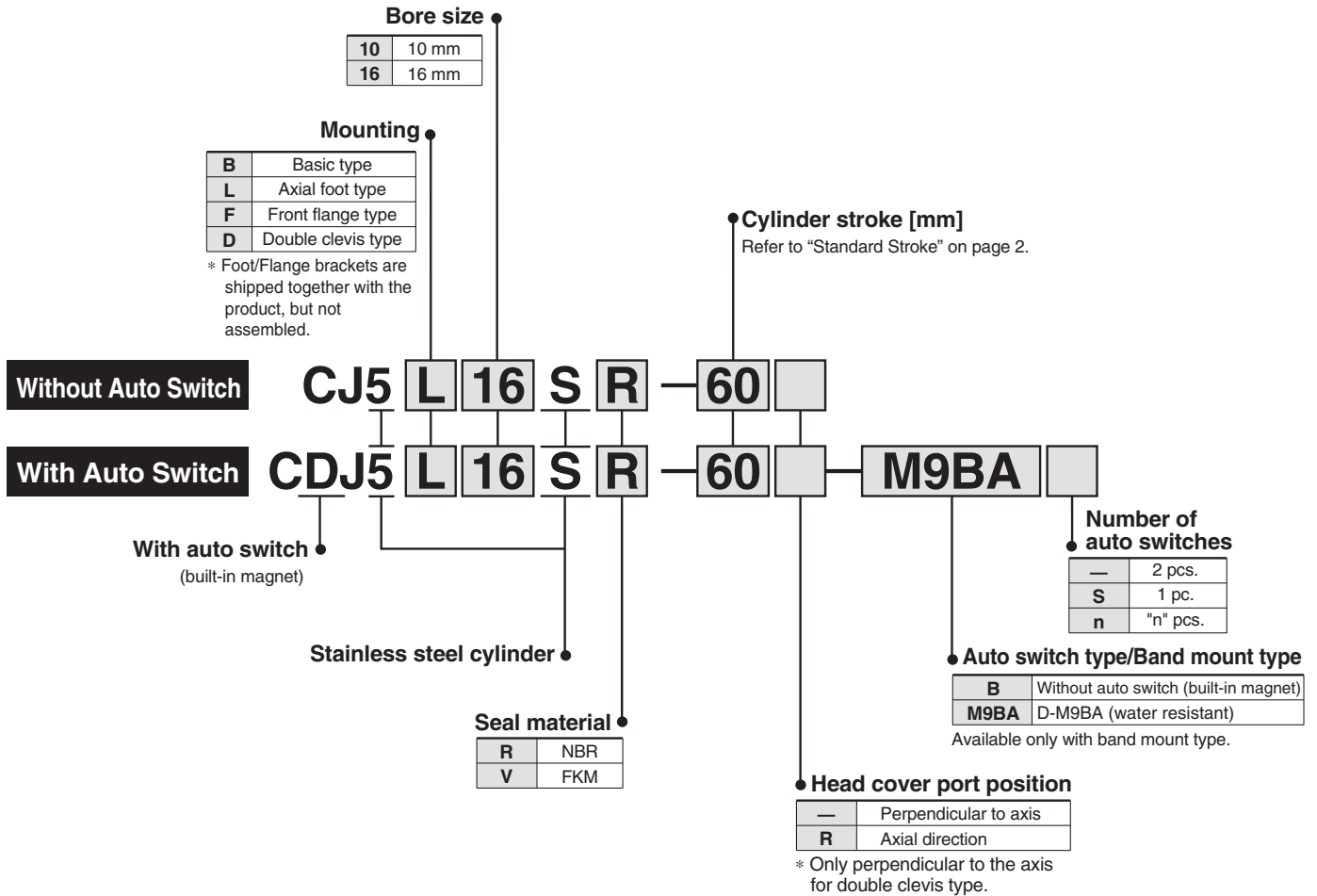

**Applicable Auto Switches**/Refer to pages to Auto Switch Guide for further information on auto switches.

Type	Special function	Electrical entry	Indicator light	Wiring (Output)	Load voltage		Auto switch model		Lead wire length (m)*				Pre-wired connector	Applicable load	
					DC	24 V	Band mounting(Ø10, Ø16)		0.5 (—)	1 (M)	3 (L)	5 (Z)		IC circuit	Relay, PLC
							Perpendicular	In-line							
Solid state auto switch	Water resistant (2-colour indication)	Grommet	Yes	3-wire(NPN)	5 V, 12 V	M9NAV	M9NA	○	○	●	○	○	—		
				3-wire(PNP)		M9PAV	M9PA	○	○	●	○				
				2-wire		M9BAV	M9BA	○	○	●	○				

\* Lead wire length symbols: — .....0.5 m (Example) D-M9NA  
M .....1 m (Example) D-M9NAM  
L .....3 m (Example) D-M9NAL  
Z .....5 m (Example) D-M9NAZ

\* Solid state auto switches marked with "○" are produced upon receipt of order.

• For details about auto switches with pre-wired connector, refer to Auto Switch Guide.

## Mounting bracket part numbers

Mounting bracket	Bore size [mm]	
	10	16
Foot bracket	CJ-L016SUS	CJK-L016SUS
Flange bracket	CJ-F016SUS	CJK-F016SUS
T-bracket*	CJ-T010SUS	CJ-T016SUS

\* The T-bracket is applicable to the double clevis type (D).

Grease pack for stainless steel cylinders/Part number: GR-R-010 (10g)

## Specifications



### Symbol

Double acting,  
Single rod, Rubber bumper

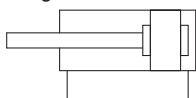

<b>Action</b>	Double acting single rod	
<b>Fluid</b>	Air	
<b>Proof pressure</b>	1 MPa	
<b>Maximum operating pressure</b>	0.7 MPa	
<b>Minimum operating pressure</b>	0.1 MPa	
<b>Ambient and fluid temperature</b>	Without auto switch: -10 to 70°C, With auto switch: -10 to 60°C	
<b>Cushion</b>	Rubber bumper	
<b>Lubrication</b>	Not required (non-lube)	
<b>Stroke length tolerance</b>	+1.0 0	
<b>Piston speed</b>	50 to 750 mm/s	
<b>Allowable kinetic energy</b>	ø10	0.035 J
	ø16	0.090 J
<b>Mounting</b>	Basic type, Axial foot type, Front flange type, Double clevis type	

## Standard Strokes

[mm]

Bore size [mm]	Standard stroke	Maximum manufacturable stroke
10	15, 30, 45, 60, 75, 100, 125, 150	400
16	15, 30, 45, 60, 75, 100, 125, 150, 175, 200	

\* Manufacture of intermediate strokes at 1 mm intervals is possible. (Spacers are not used.)

\* For the one with auto switch, refer to the minimum stroke for auto switch mounting. (P. 14)

## Mounting Types and Accessories

●...Supplied with the product. ○...Please order separately.

Mounting		Basic style	Axial foot style	Rod side flange style	Double clevis style *	
Standard equipment	Mounting nut	●	●	●	—	
	Rod end nut	●	●	●	●	
	Clevis pin	—	—	—	●	
Option	Single knuckle joint	○	○	○	○	
	Double knuckle joint (With pin) *	○	○	○	○	
	T-bracket	—	—	—	○	
	Rod end cap	Flat type	○	○	○	○
		Round type	○	○	○	○

\* Pin and retaining ring are shipped together with double clevis and double knuckle joint.

## Weights

[g]

Bore size [mm]		10	16
Basic weight*		52	96
Additional weight per 15 mm of stroke		4	6.5
Mounting bracket weight	Axial foot type	22	22
	Front flange type	16	16
	Double clevis type (with pin)**	6	16

\* The mounting nut and rod end nut are included in the basic weight.

\*\* The mounting nut is not included with the double clevis type.

Calculation (Example) CJ5L10SR-45

- Basic weight ..... 52 g (ø10)
  - Additional weight ..... 4 g/15 mm stroke
  - Cylinder stroke ..... 45 mm
  - Mounting bracket weight ... 22 g (axial foot type)
- 52 + 4/15 x 45 + 22 = 86 g

# Series CJ5-S

## Construction (Cannot be disassembled)

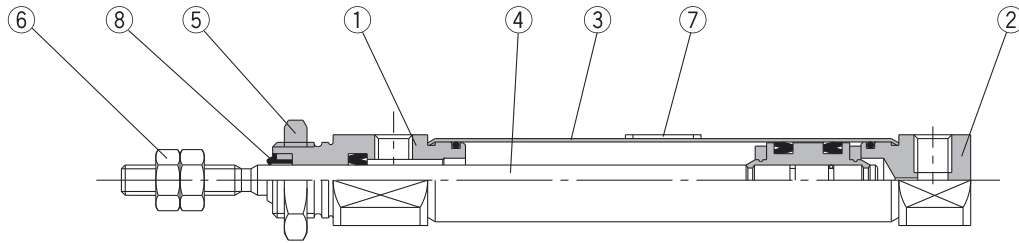

### Parts list

No.	Description	Material	
1	Rod cover	SUS304	
2	Head cover	SUS304	
3	Cylinder tube	SUS304	
4	Piston rod	SUS304	
5	Mounting nut	SUS304	
6	Rod end nut	SUS304	
7	Label protector	PET	
8	Water resistant scraper	CJ5□□SR	NBR
		CJ5□□SV	FKM

Note) Component part material and surface treatment other than listed above are the same as the standard type of Series CJ2.

## Dimensions

### Basic type (B)/C□J5B□S<sup>R</sup><sub>V</sub>

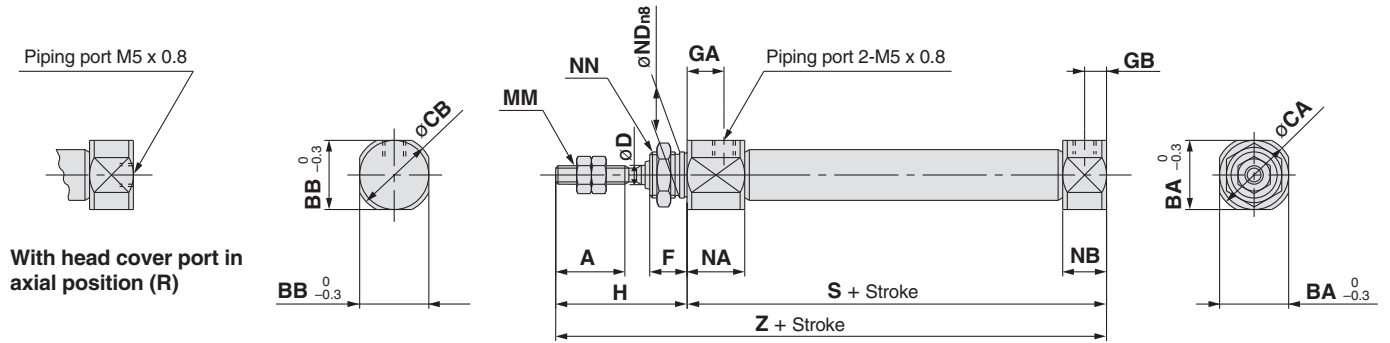

Bore size [mm]	A	BA	BB	CA	CB	D	F	GA	GB	H	MM	NN	NA	NB	NDn8	S	Z
10	15	15	12	17	14	4	8	8	5	28	M4 x 0.7	M10 x 1.0	12.5	9.5	10 <sup>0</sup> <sub>-0.022</sub>	46	74
16	15	18.3	18.3	20	20	5	8	8	5	28	M5 x 0.8	M12 x 1.0	12.5	9.5	12 <sup>0</sup> <sub>-0.027</sub>	47	75

### Axial foot type (L)/C□J5L□S<sup>R</sup><sub>V</sub>

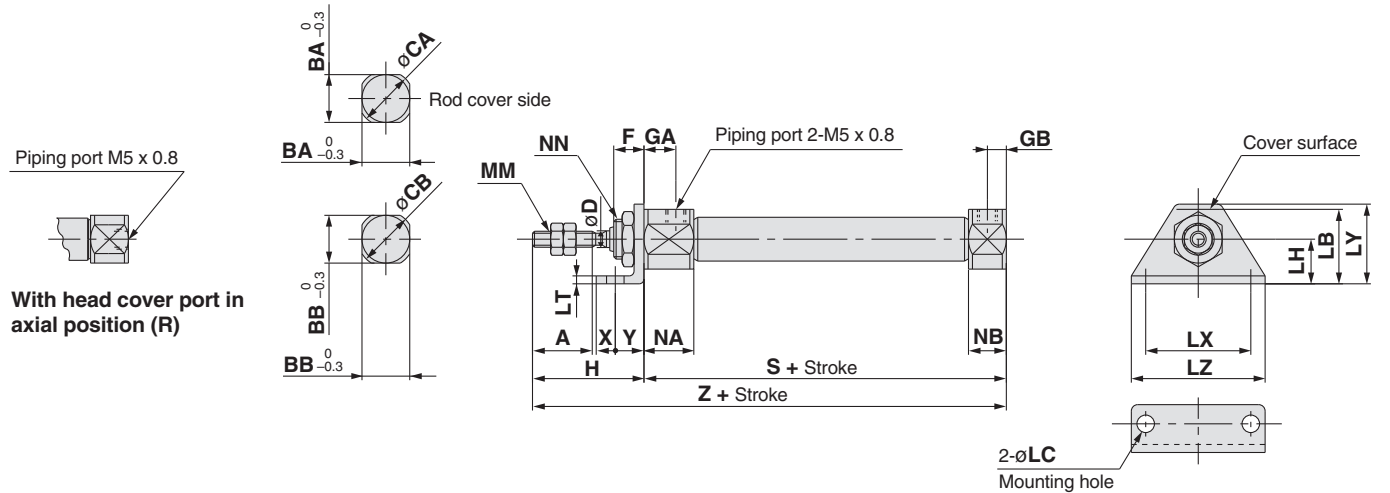

Bore size [mm]	A	BA	BB	CA	CB	D	F	GA	GB	H	LB	LC	LH	LT	LX	LY	LZ	MM	NN	NA	NB	S	X	Y	Z
10	15	15	12	17	14	4	8	8	5	28	21.5	5.5	14	2.5	33	25	42	M4 x 0.7	M10 x 1.0	12.5	9.5	46	6	9	74
16	15	18.3	18.3	20	20	5	8	8	5	28	23	5.5	14	2.5	33	25	42	M5 x 0.8	M12 x 1.0	12.5	9.5	47	6	9	75

# Series CJ5-S

## Dimensions

### Front flange type (F)/C□J5F□S<sup>R</sup><sub>V</sub>

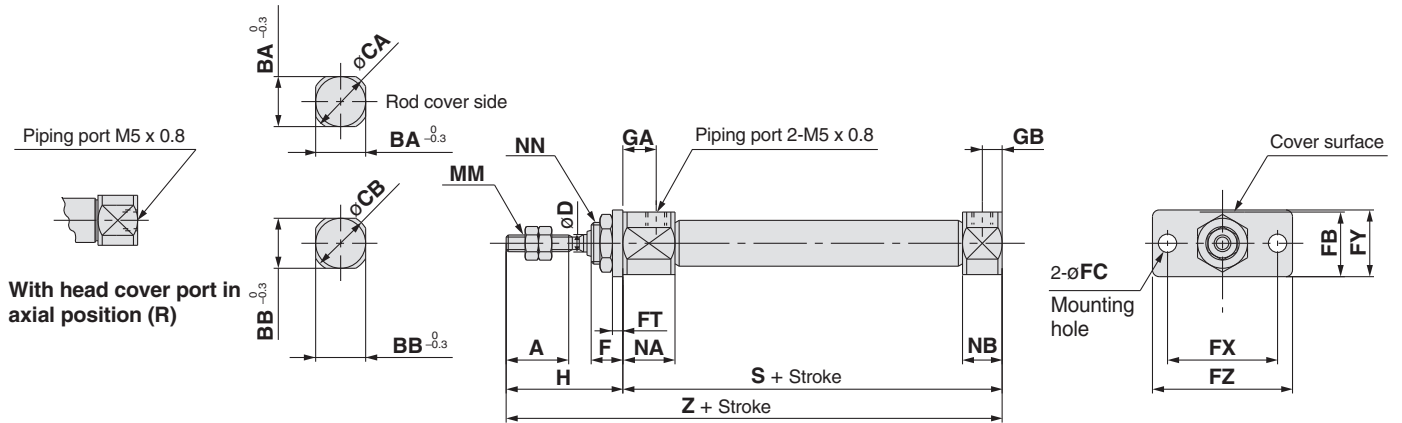

Bore size [mm]	A	BA	BB	CA	CB	D	F	FB	FC	FT	FX	FY	FZ	GA	GB	H	MM	NN	NA	NB	S	Z
10	15	15	12	17	14	4	8	17.5	5.5	2.5	33	20	42	8	5	28	M4 x 0.7	M10 x 1.0	12.5	9.5	46	74
16	15	18.3	18.3	20	20	5	8	19	5.5	2.5	33	20	42	8	5	28	M5 x 0.8	M12 x 1.0	12.5	9.5	47	75

### Double clevis type (D)/C□J5D□S<sup>R</sup><sub>V</sub>

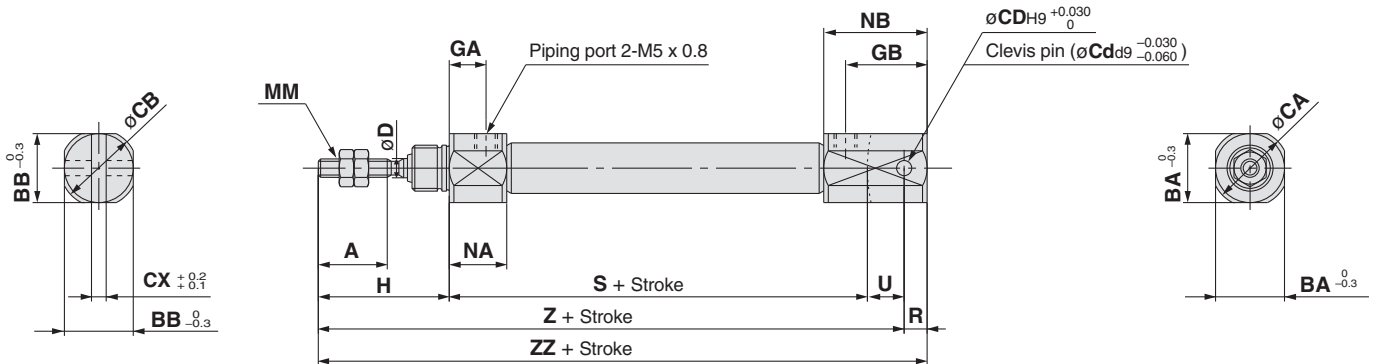

Bore size [mm]	A	BA	BB	CA	CB	CD (Cd)	CX	D	GA	GB	H	MM	NA	NB	R	S	U	Z	ZZ
10	15	15	12	17	14	3.3	3.2	4	8	18	28	M4 x 0.7	12.5	22.5	5	46	8	82	87
16	15	18.3	18.3	20	20	5	6.5	5	8	23	28	M5 x 0.8	12.5	27.5	8	47	10	85	93

\* Clevis pin and retaining ring are shipped together.

## Accessory Dimensions

### Single knuckle joint

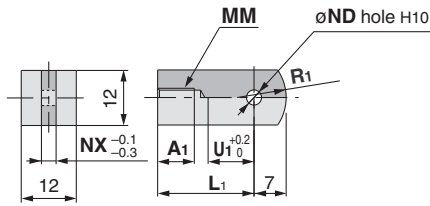

Material: SUS304

Part no.	Applicable bore size [mm]	A1	L1	MM	ND <sub>H10</sub>	NX	R1	U1
I-J010SUS	10	8	21	M4 x 0.7	3.3 <sup>+0.048</sup> <sub>0</sub>	3.1	8	9
I-J016SUS	16	8	25	M5 x 0.8	5 <sup>+0.048</sup> <sub>0</sub>	6.4	12	14

### Clevis pin

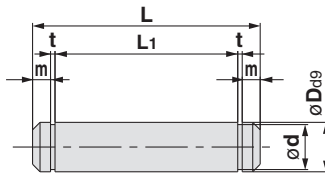

Material: Pin and retaining ring both stainless steel 304

Part no.	Applicable bore size [mm]	D <sub>d9</sub>	d	L	L1	m	t	Snap ring
CD-J010	10	3.3 <sup>-0.030</sup> <sub>-0.060</sub>	3	15.2	12.2	1.2	0.3	C type 3.2
CD-Z015SUS	16	5 <sup>-0.030</sup> <sub>-0.060</sub>	4.8	22.7	18.3	1.5	0.7	C type 5

\* Retaining rings are included.

### Knuckle pin

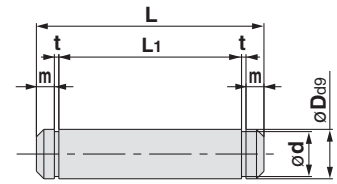

Material: Pin and retaining ring both stainless steel 304

Part no.	Applicable bore size [mm]	D <sub>d9</sub>	d	L	L1	m	t	Snap ring
CD-J010	10	3.3 <sup>-0.030</sup> <sub>-0.060</sub>	3	15.2	12.2	1.2	0.3	C type 3.2
IY-J015SUS	16	5 <sup>-0.030</sup> <sub>-0.060</sub>	4.8	16.6	12.2	1.5	0.7	C type 5

\* Clevis pin is used instead for ø10.

\* Retaining rings are included.

### Double knuckle joint

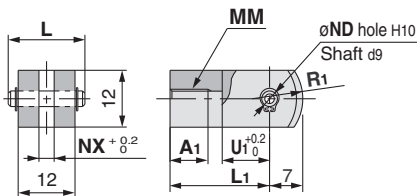

\* Knuckle pin and retaining ring are packaged together.

Material: SUS304

Part no.	Applicable bore size [mm]	A1	L	L1	MM	ND <sub>d9</sub>
Y-J010SUS	10	8	15.2	21	M4 x 0.7	3.3 <sup>-0.030</sup> <sub>-0.060</sub>
Y-J016SUS	16	11	16.6	21	M5 x 0.8	5 <sup>-0.030</sup> <sub>-0.060</sub>

Part no.	ND <sub>H10</sub>	NX	R1	U1
Y-J010SUS	3.3 <sup>+0.048</sup> <sub>0</sub>	3.2	8	10
Y-J016SUS	5 <sup>+0.048</sup> <sub>0</sub>	6.5	12	10

### Mounting nut

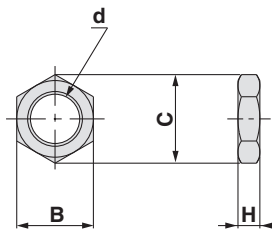

Material: SUS304

Part no.	Applicable bore size [mm]	B	C	d	H
SNJ-016SUS	10	14	16.2	M10 x 1.0	4
SNKJ-016SUS	16	17	19.6	M12 x 1.0	4

### Rod end nut

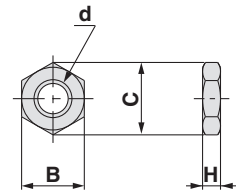

Material: SUS304

Part no.	Applicable bore size [mm]	B	C	d	H
NTJ-010SUS	10	7	8.1	M4 x 0.7	3.2
NTJ-015SUS	16	8	9.2	M5 x 0.8	4

### T-bracket

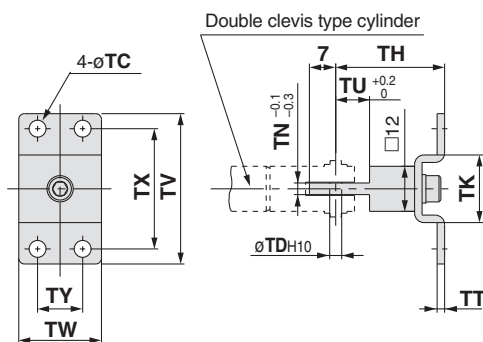

Material: SUS304

Part no.	Applicable bore size [mm]	TC	TD <sub>H10</sub>	TH	TK	TN	TT	TU	TV	TW	TX	TY
CJ-T010SUS	10	4.5	3.3 <sup>+0.048</sup> <sub>0</sub>	29	18	3.1	2	9	40	22	32	12
CJ-T016SUS	16	5.5	5 <sup>+0.048</sup> <sub>0</sub>	35	20	6.4	2.5	14	48	28	38	16

### Rod end cap

Flat type/CJ-CF□□□

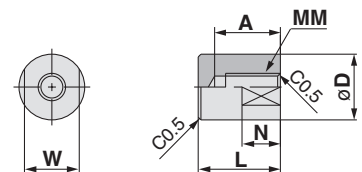

Round type/CJ-CR□□□

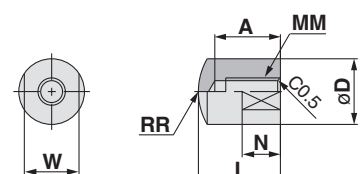

Material: Polyacetal

Part no.	Applicable bore size [mm]	A		D	L	MM	N	R	W
		Flat type	Round type						
CJ-CF010	CJ-CR010	10	8	10	13	M4 x 0.7	6	10	8
CJ-CF016	CJ-CR016	16	10	12	15	M5 x 0.8	7	12	10

# Stainless Steel Cylinder

## Series CG5-S

ø20, ø25, ø32, ø40, ø50, ø63, ø80, ø100

### How to Order

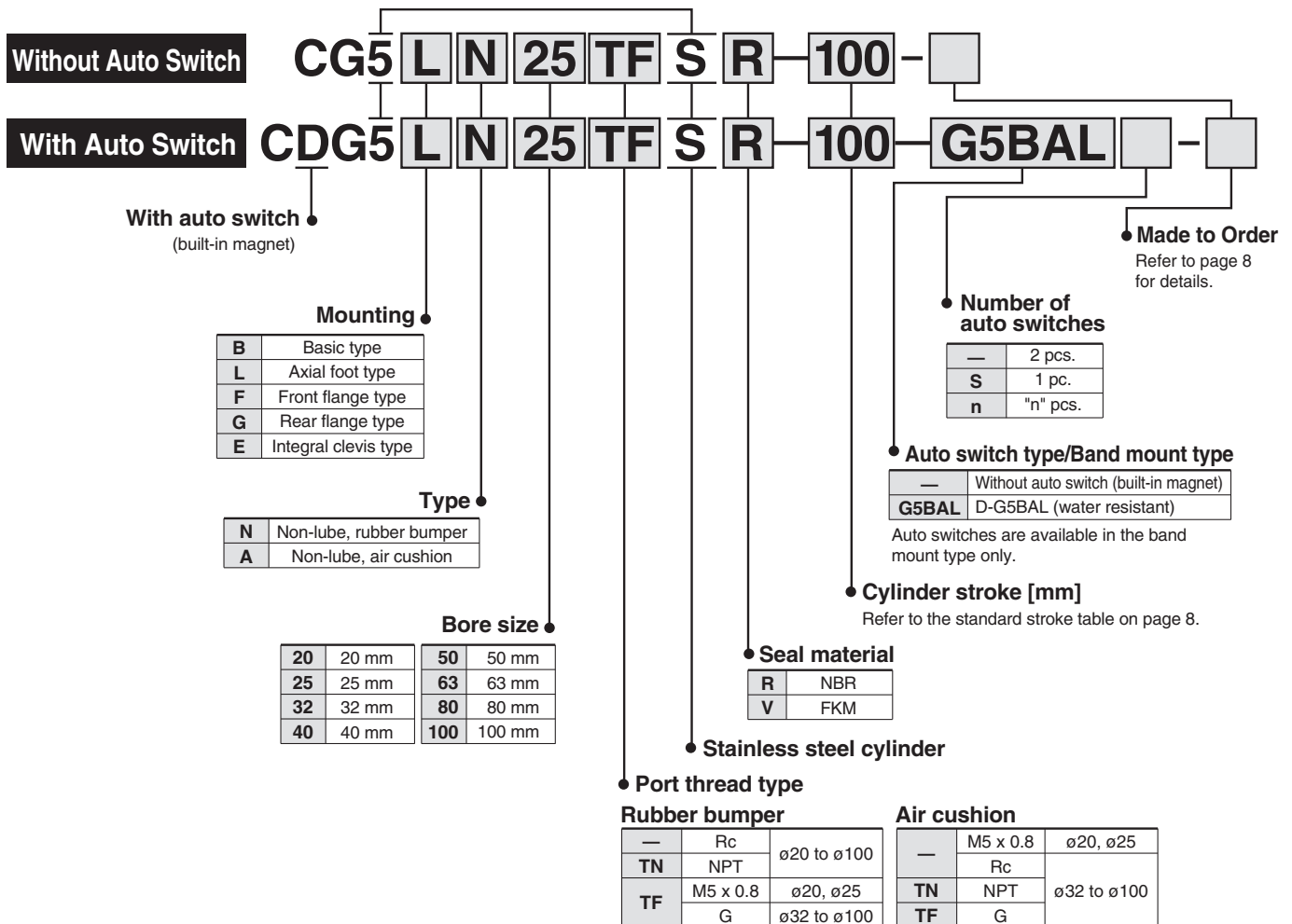

### Applicable Auto Switches/Refer to Auto Switch Guide for further information on auto switches.

Type	Special function	Electrical entry	Indicator light	Wiring (Output)	Load voltage		Auto switch model	Lead wire length [m]*		Pre-wired connector	Applicable load
					DC	DC		3 (L)	5 (Z)		
Solid state auto switch	Water resistant (2-colour indication)	Grommet	Yes	2-wire	24 V	12 V	G5BA	●	○	○	Relay, PLC

\* Lead wire length symbols: 3 m.....L (Example) G5BAL  
5 m.....Z (Example) G5BAZ

\* Solid state auto switches marked with "○" are produced upon receipt of order.

• For details about auto switches with pre-wired connector, refer to Auto Switch Guide.

### Mounting bracket part numbers

Mounting bracket	Bore size [mm]							
	20	25	32	40	50	63	80	100
<b>Axial foot</b> <small>Note 1)</small>	CG-L020SUS	CG-L025SUS	CG-L032SUS	CG-L040SUS	CG-L050SUS	CG-L063SUS	CG-L080SUS	CG-L100SUS
<b>Flange</b>	CG-F020SUS	CG-F025SUS	CG-F032SUS	CG-F040SUS	CG-F050SUS	CG-F063SUS	CG-F080SUS	CG-F100SUS
<b>Trunnion bracket</b> <small>Note 2)</small>	CG-E020SUS		CG-E032SUS		CG-E050SUS		CG-E080SUS	

Note 1) Order two foot brackets for each cylinder.

Note 2) Includes a clevis pin and 2 retaining rings.

Grease pack for stainless steel cylinders/Part number: GR-R-010 (10g)

# Stainless Steel Cylinder *Series CG5-S*

## Specifications



### Symbol

Double acting,  
Single rod, Rubber bumper

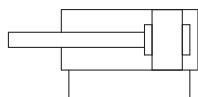

Air cushion

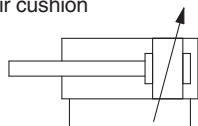

<b>Action</b>		Double acting single rod
<b>Fluid</b>		Air
<b>Proof pressure</b>		1.5 MPa
<b>Maximum operating pressure</b>		1.0 MPa
<b>Minimum operating pressure</b>		0.05 MPa
<b>Ambient and fluid temperature</b>		Without auto switch: -10 to 70°C, With auto switch: -10 to 60°C
<b>Cushion</b>		Rubber bumper, Air cushion
<b>Piston speed</b>	ø20 to ø63	50 to 1000 mm/s
	ø80, ø100	50 to 700 mm/s
<b>Lubrication</b>		Not required (Non-lube)
<b>Stroke length tolerance</b>	ø20 to ø63	to 1000 $^{+1.4}_0$ mm, to 1200 $^{+1.8}_0$ mm
	ø80, ø100	to 1000 $^{+1.4}_0$ mm, to 1500 $^{+1.8}_0$ mm
<b>Mounting</b>		Basic type, Axial foot type, Front flange type, Rear flange type, Integral clevis type

## Standard Strokes

[mm]

Bore size [mm]	Standard stroke	Long stroke	Maximum manufacturable stroke
20	25, 50, 75, 100, 125, 150, 200	201 to 350	1500
25	25, 50, 75, 100, 125, 150, 200 250, 300	301 to 400	
32		301 to 450	
40		301 to 800	
50, 63		301 to 1200	
80		301 to 1400	
100		301 to 1500	

\* Manufacture of intermediate strokes at 1 mm intervals is possible. (Spacers are not used.)

\* Long stroke applies to the axial foot style and the rod side flange style. If other mounting brackets are used, or the length exceeds the long stroke limit, the stroke should be determined based on the stroke selection table, in that case, please contact SMC.



**Made to Order Specifications**  
(For details, refer to pages 15 to 17.)

Symbol	Specifications
-XA□	Change of rod end shape
-XB6	Heat resistant cylinder (150°C)*

\* Heat resistant grease (non-food grease) is used.

## Accessories

●...Supplied with the product. ○...Please order separately.

Mounting		Basic style	Axial foot style	Rod side flange style	Head side flange style	Clevis integrated style
Standard equipment	Rod end nut	●	●	●	●	●
Option	Single knuckle joint	○	○	○	○	○
	Double knuckle joint (With pin & retaining ring)	○	○	○	○	○
	Pivot bracket (With pin and retaining ring)	—	—	—	—	○

## Weights

[kg]

Bore size		20	25	32	40	50	63	80	100
Standard weight	Basic type	0.32	0.42	0.61	0.97	1.78	2.73	5.20	8.13
	Axial foot type	0.40	0.53	0.72	1.13	2.12	3.19	5.91	9.50
	Flange type	0.43	0.53	0.71	1.12	2.04	3.25	5.86	9.29
	Integral clevis type	0.37	0.48	0.72	1.12	2.17	3.26	6.48	9.94
Trunnion bracket		0.08	0.08	0.18	0.18	0.46	0.46	1.65	1.65
Single knuckle joint		0.04	0.07	0.07	0.11	0.22	0.22	0.53	0.78
Double knuckle joint (with pin)		0.05	0.09	0.09	0.18	0.33	0.33	0.73	1.07
Additional weight per 50 mm of stroke		0.06	0.08	0.14	0.18	0.27	0.33	0.50	0.73
Additional weight with air cushion		0.02	0.02	0.03	0.02	0.06	0.07	0.14	0.16

Calculation (Example) CG5LA 20SR-100  
(Foot type ø20, 100mm stroke)

- Basic weight ..... 0.40 kg (Foot type ø20)
  - Additional stroke weight ..... 0.06 kg/50 mm stroke
  - Air cylinder stroke ..... 100 mm
  - Additional air cushion weight ..... 0.02 kg
- 0.40 + 0.06 x 100/50 + 0.02 = 0.54 kg

# Series CG5-S

## Construction

With air cushion

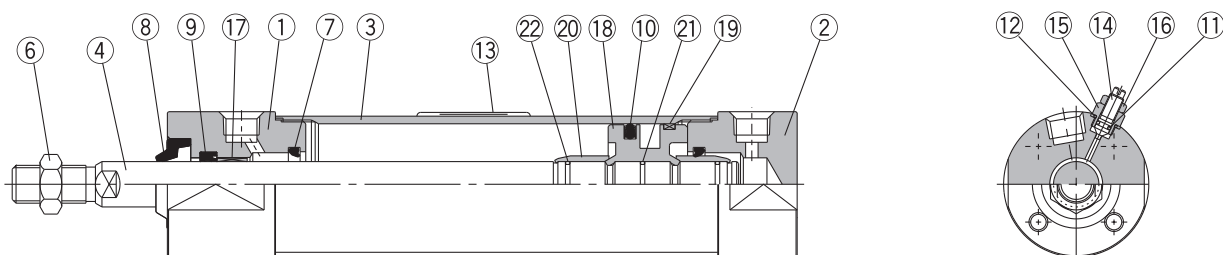

### Component Parts

No.	Description	Material
1	Rod cover	Stainless steel 304
2	Head cover	Stainless steel 304
3	Cylinder tube	Stainless steel 304
4	Piston rod	Stainless steel 304   Hard chrome plated
6	Rod end nut	Stainless steel 304
7	Cushion seal	Urethane
14	Cushion valve	Stainless steel 304
15	Valve retainer	Stainless steel 304
16	Lock nut	Stainless steel 304
17	Bushing	Bearing alloy
18	Piston	Aluminium alloy
19	Wearing	Resin
20	Cushion ring	Aluminium alloy

No.	Description	Material	
		CG5□□□SR	CG5□□□SV
8	Water resistant scraper	NBR	FKM
9	Rod seal		
10	Piston seal		
11	Valve seal		
12	Valve retainer gasket		
21	Piston gasket		
22	Cushion ring gasket		
13	Label protector	PET	

Note 1) Component part material and surface treatment other than listed above are the same as the standard type of Series CG1.

Note 2) For cylinders with an auto switch, the piston is fixed with a magnet.

### Replacement Parts/Seal Kit

Bore size (mm)	Rubber bumper		Air cushion	
	CG5□N□SR	CG5□N□SV	CG5□A□SR	CG5□A□SV
20	CG5N20SR-PS	CG5N20SV-PS	CG5A20SR-PS	CG5A20SV-PS
25	CG5N25SR-PS	CG5N25SV-PS	CG5A25SR-PS	CG5A25SV-PS
32	CG5N32SR-PS	CG5N32SV-PS	CG5A32SR-PS	CG5A32SV-PS
40	CG5N40SR-PS	CG5N40SV-PS	CG5A40SR-PS	CG5A40SV-PS
Contents	Set of ⑨ and ⑩ above		Set of ⑨, ⑩, ⑪ and ⑫ above	

\* Seal kit includes a grease pack (10 g).

Order with the following part number when only the grease pack is needed.

**Grease pack part number: GR-R-010 (10 g)**

### ⚠ Caution

When disassembling cylinders with bore sizes of  $\phi 20$  through  $\phi 40$ , grip the double flat part of either the tube cover or the rod cover with a vise and loosen the other side with a wrench or a monkey wrench, etc., and then remove the cover. When retightening, tighten approximately 2 degrees more than the original position. (Cylinders with  $\phi 50$  or larger bore sizes are tightened with a large tightening torque and cannot be disassembled.)

## Dimensions

### Basic type (B)/C□G5BN□S<sup>R</sup><sub>V</sub>: With rubber bumper

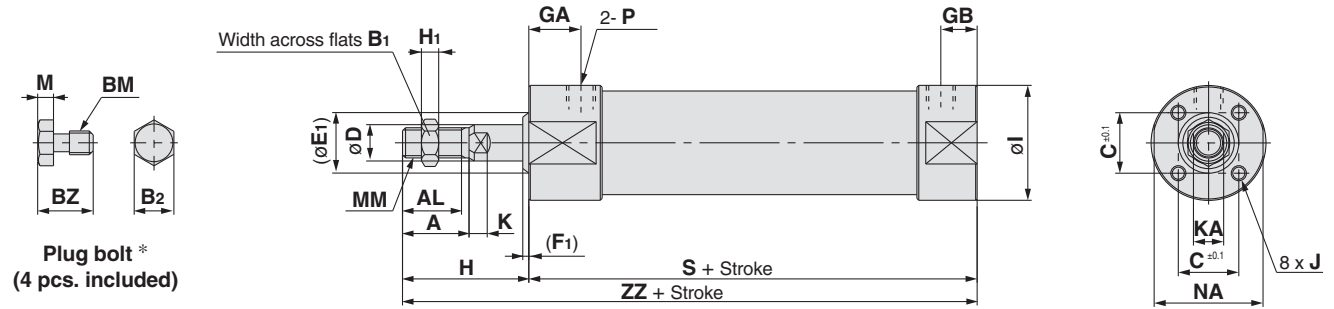

Bore size [mm]	Stroke range	Rc, NPT port			G port			A	AL	B <sub>1</sub>	B <sub>2</sub>	BM	BZ	C	D	E <sub>1</sub>	F <sub>1</sub>	H	H <sub>1</sub>	I	J	K	KA	M	MM	NA	S	ZZ
		Standard	GA	GB	P	GA	GB	P																				
20	Up to 350	18	12	1/8	18	12	M5 x 0.8	18	15.5	13	7	M4 x 0.7	9	16.5	8	15	3	35	5	31	M4 x 0.7 depth 7	5	6	3	M8 x 1.25	29	83	118
25	Up to 400	18	12	1/8	18	12	M5 x 0.8	22	19.5	17	8	M5 x 0.8	9.5	18.5	10	17	3	40	6	33	M5 x 0.8 depth 8	5.5	8	3.5	M10 x 1.25	29	83	123
32	Up to 450	18	12	1/8	18	12	1/8	22	19.5	17	8	M5 x 0.8	9.5	20	12	19	3	40	6	38	M5 x 0.8 depth 8	5.5	10	3.5	M10 x 1.25	35.5	85	125
40	Up to 800	19	13	1/8	19	13	1/8	30	27	19	10	M6 x 1.0	12	26	16	23	3	50	8	47	M6 x 1.0 depth 12	6	14	4	M14 x 1.5	44	93	143
50	Up to 1200	21	14	1/4	21	14	1/4	35	32	27	13	M8 x 1.25	15.5	32	20	28	3	58	11	58	M8 x 1.25 depth 16	7	18	5.5	M18 x 1.5	55	109	167
63	Up to 1200	21	14	1/4	21	14	1/4	35	32	27	17	M10 x 1.5	19	38	20	28	3	58	11	72	M10 x 1.5 depth 16	7	18	7	M18 x 1.5	69	109	167
80	Up to 1400	28	20	3/8	28	20	3/8	40	37	32	17	M10 x 1.5	19	50	25	33	3	71	13	89	M10 x 1.5 depth 22	10	22	7	M22 x 1.5	80	130	201
100	Up to 1500	29	20	1/2	29	20	1/2	40	37	41	19	M12 x 1.75	24	60	30	38	3	71	16	110	M12 x 1.75 depth 23	10	26	8	M26 x 1.5	100	131	202

\* Install plug bolts, which are included, in any unused mounting holes.

### Basic type (B)/C□G5BA□S<sup>R</sup><sub>V</sub>: With air cushion

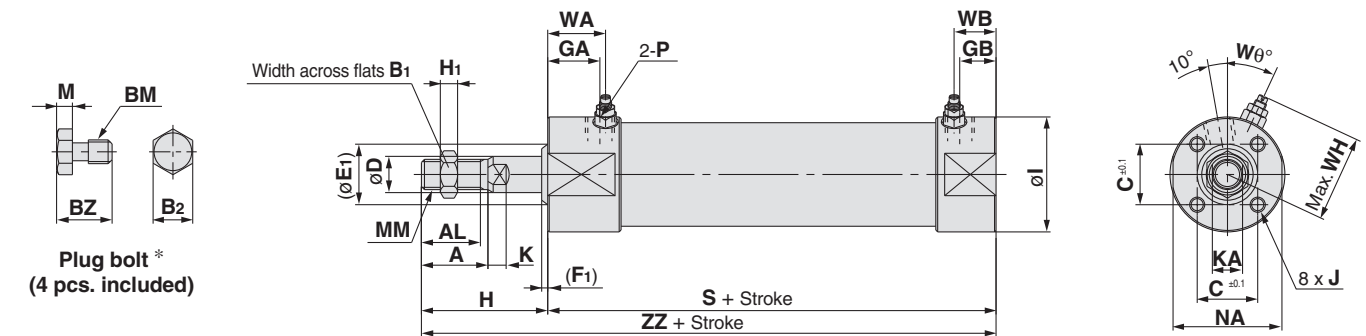

Bore size [mm]	Stroke range	Rc, NPT port			G port			A	AL	B <sub>1</sub>	B <sub>2</sub>	BM	BZ	C	D	E <sub>1</sub>	F <sub>1</sub>	H	H <sub>1</sub>	I	J	K	KA	M	MM	NA	S
		Standard	GA	GB	P	GA	GB	P																			
20	Up to 350	18	12	M5 x 0.8	18	12	M5 x 0.8	18	15.5	13	7	M4 x 0.7	9	16.5	8	15	3	35	5	31	M4 x 0.7 depth 7	5	6	3	M8 x 1.25	29	83
25	Up to 400	18	12	M5 x 0.8	18	12	M5 x 0.8	22	19.5	17	8	M5 x 0.8	9.5	18.5	10	17	3	40	6	33	M5 x 0.8 depth 8	5.5	8	3.5	M10 x 1.25	29	83
32	Up to 450	18	12	1/8	18	12	1/8	22	19.5	17	8	M5 x 0.8	9.5	20	12	19	3	40	6	38	M5 x 0.8 depth 8	5.5	10	3.5	M10 x 1.25	35.5	85
40	Up to 800	19	13	1/8	19	13	1/8	30	27	19	10	M6 x 1.0	12	26	16	23	3	50	8	47	M6 x 1.0 depth 12	6	14	4	M14 x 1.5	44	93
50	Up to 1200	21	14	1/4	21	14	1/4	35	32	27	13	M8 x 1.25	15.5	32	20	28	3	58	11	58	M8 x 1.25 depth 16	7	18	5.5	M18 x 1.5	55	109
63	Up to 1200	21	14	1/4	21	14	1/4	35	32	27	17	M10 x 1.5	19	38	20	28	3	58	11	72	M10 x 1.5 depth 16	7	18	7	M18 x 1.5	69	109
80	Up to 1400	28	20	3/8	28	20	3/8	40	37	32	17	M10 x 1.5	19	50	25	33	3	71	13	89	M10 x 1.5 depth 22	10	22	7	M22 x 1.5	80	130
100	Up to 1500	29	20	1/2	29	20	1/2	40	37	41	19	M12 x 1.75	24	60	30	38	3	71	16	110	M12 x 1.75 depth 23	10	26	8	M26 x 1.5	100	131

\* Install plug bolts, which are included, in any unused mounting holes.

Bore size [mm]	WA	WB	WH	Wθ	ZZ
20	22	16	23	30°	118
25	22	16	25	30°	123
32	22	16	28.5	25°	125
40	22	16	33	20°	143
50	25	18	40.5	20°	167
63	25	18	47.5	20°	167
80	30	22	60.5	20°	201
100	31	22	71	20°	202

# Series CG5-S

## Dimensions

### Axial foot style (L): C□G5L<sup>N</sup><sub>A</sub>□S<sup>R</sup><sub>V</sub>

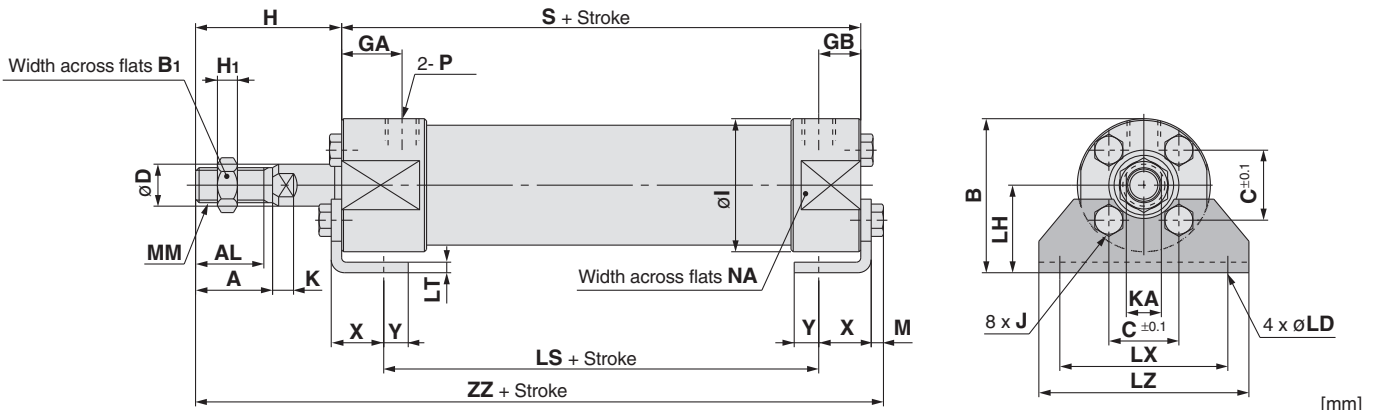

Bore size [mm]	Stroke range	Rc, NPT port			G port			A	AL	B <sub>1</sub>	B	C	D	H	H <sub>1</sub>	I	J	K	KA	LD	LH	LS	LT	LX	LZ	M					
		GA	GB	P	GA	GB	P	[mm]																							
20	Up to 350	18	12	1/8 <sup>(1)</sup>	18	12	M5 x 0.8	18	15.5	13	37.5	16.5	8	35	5	31	M4 x 0.7	5	6	6	22	59	3	40	50	3					
25	Up to 400	18	12	1/8 <sup>(1)</sup>	18	12	M5 x 0.8	22	19.5	17	41.5	18.5	10	40	6	33	M5 x 0.8	5.5	8	6	25	59	3	44	60	3.5					
32	Up to 450	18	12	1/8	18	12	1/8	22	19.5	17	44	20	12	40	6	38	M5 x 0.8	5.5	10	7.2	25	59	3	44	60	3.5					
40	Up to 800	19	13	1/8	19	13	1/8	30	27	19	53.5	26	16	50	8	47	M6 x 1.0	6	14	7.2	30	66	3	54	75	4					
50	Up to 1200	21	14	1/4	21	14	1/4	35	32	27	69	32	20	58	11	58	M8 x 1.25	7	18	10	40	74	4	66	90	5.5					
63	Up to 1200	21	14	1/4	21	14	1/4	35	32	27	81	38	20	58	11	72	M10 x 1.5	7	18	12	45	74	4	82	110	7					
80	Up to 1400	28	20	3/8	28	20	3/8	40	37	32	99.5	50	25	71	13	89	M10 x 1.5	10	22	12	55	82	4	100	130	7					
100	Up to 1500	29	20	1/2	29	20	1/2	40	37	41	125	60	30	71	16	110	M12 x 1.75	10	26	14	70	83	6	120	160	8					

\* Foot brackets and plug bolts are installed when shipped from factory.

Note 1) ø20 and ø25 cylinders with an air cushion: M5 x 0.8

Note 2) Refer to the basic type (B)/CG5BA□S\* for the dimensions of air cushion needles.

Bore size (mm)	MM	NA	S	X	Y	ZZ
20	M8 x 1.25	29	83	15	7	124
25	M10 x 1.25	29	83	15	7	129.5
32	M10 x 1.25	35.5	85	16	6	131.5
40	M14 x 1.5	44	93	16.5	6.5	150
50	M18 x 1.5	55	109	21.5	11.5	176.5
63	M18 x 1.5	69	109	21.5	11.5	178
80	M22 x 1.5	80	130	28	17	212
100	M26 x 1.5	100	131	30	15	216

### Rod side flange style (F): C□G5F<sup>N</sup><sub>A</sub>□S<sup>R</sup><sub>V</sub>

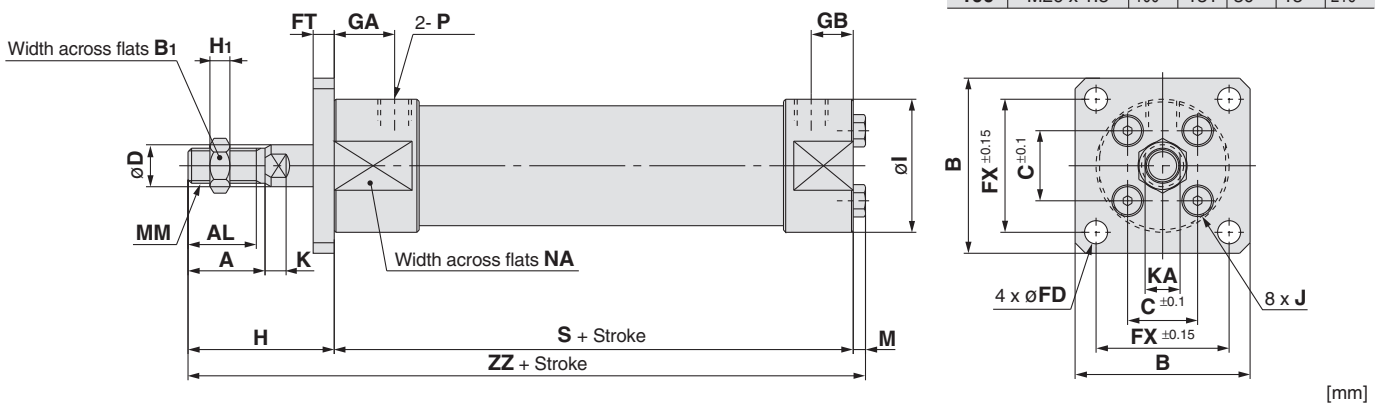

Bore size [mm]	Stroke range	Rc, NPT port			G port			A	AL	B <sub>1</sub>	B	C	D	FX	FD	FT	H	H <sub>1</sub>	I	J	K	KA	M	MM	NA	S	ZZ				
		GA	GB	P	GA	GB	P	[mm]																							
20	Up to 350	18	12	1/8 <sup>(1)</sup>	18	12	M5 x 0.8	18	15.5	13	50	16.5	8	36	5.5	6	35	5	31	M4 x 0.7	5	6	3	M8 x 1.25	29	83	121				
25	Up to 400	18	12	1/8 <sup>(1)</sup>	18	12	M5 x 0.8	22	19.5	17	50	18.5	10	36	5.5	6	40	6	33	M5 x 0.8	5.5	8	3.5	M10 x 1.25	29	83	126.5				
32	Up to 450	18	12	1/8	18	12	1/8	22	19.5	17	50	20	12	38	6.6	6	40	6	38	M5 x 0.8	5.5	10	3.5	M10 x 1.25	35.5	85	128.5				
40	Up to 800	19	13	1/8	19	13	1/8	30	27	19	60	26	16	46	6.6	6	50	8	47	M6 x 1.0	6	14	4	M14 x 1.5	44	93	147				
50	Up to 1200	21	14	1/4	21	14	1/4	35	32	27	75	32	20	58	9	9	58	11	58	M8 x 1.25	7	18	5.5	M18 x 1.5	55	109	172.5				
63	Up to 1200	21	14	1/4	21	14	1/4	35	32	27	90	38	20	70	11	9	58	11	72	M10 x 1.5	7	18	7	M18 x 1.5	69	109	174				
80	Up to 1400	28	20	3/8	28	20	3/8	40	37	32	100	50	25	82	11	9	71	13	89	M10 x 1.5	10	22	7	M22 x 1.5	80	130	208				
100	Up to 1500	29	20	1/2	29	20	1/2	40	37	41	125	60	30	100	14	10	71	16	110	M12 x 1.75	10	26	8	M26 x 1.5	100	131	210				

\* Flange bracket and plug bolt are installed when shipped from factory.

Note 1) ø20 and ø25 cylinders with an air cushion: M5 x 0.8

Note 2) Refer to the basic type (B)/CG5BA□S\* for the dimensions of air cushion needles.

## Dimensions

### Head side flange style (G): C□G5G<sub>A</sub><sup>N</sup>□S<sub>V</sub><sup>R</sup>

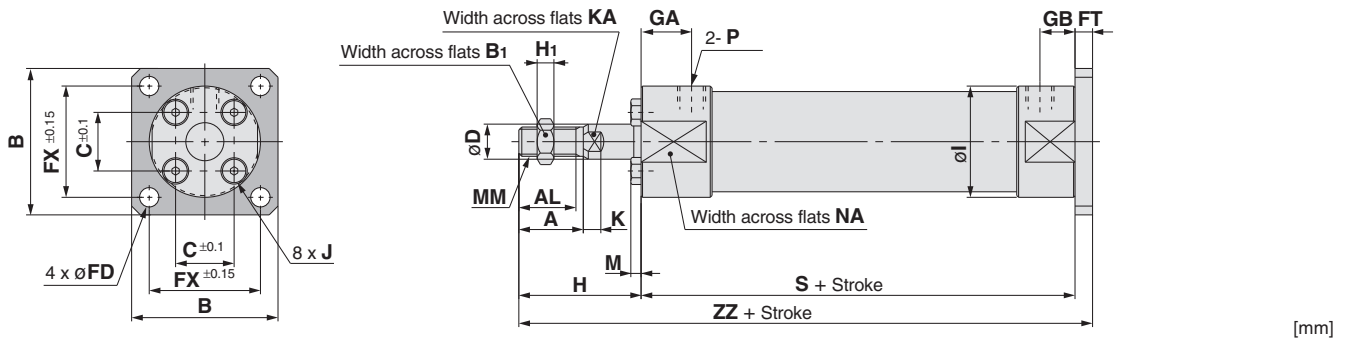

Bore size [mm]	Stroke range	Rc, NPT port			G port			A	AL	B <sub>1</sub>	B	C	D	FX	FD	FT	H	H <sub>1</sub>	I	J	K	KA	M	MM	NA	S	ZZ
		Standard	GA	GB	P	GA	GB	P																			
20	Up to 200	18	12	1/8 <sup>(1)</sup>	18	12	M5 x 0.8	18	15.5	13	50	16.5	8	36	5.5	6	35	5	31	M4 x 0.7	5	6	3	M8 x 1.25	29	83	124
25	Up to 300	18	12	1/8 <sup>(1)</sup>	18	12	M5 x 0.8	22	19.5	17	50	18.5	10	36	5.5	6	40	6	33	M5 x 0.8	5.5	8	3.5	M10 x 1.25	29	83	129
32	Up to 300	18	12	1/8	18	12	1/8	22	19.5	17	50	20	12	38	6.6	6	40	6	38	M5 x 0.8	5.5	10	3.5	M10 x 1.25	35.5	85	131
40	Up to 500	19	13	1/8	19	13	1/8	30	27	19	60	26	16	46	6.6	6	50	8	47	M6 x 1.0	6	14	4	M14 x 1.5	44	93	149
50	Up to 600	21	14	1/4	21	14	1/4	35	32	27	75	32	20	58	9	9	58	11	58	M8 x 1.25	7	18	5.5	M18 x 1.5	55	109	176
63	Up to 600	21	14	1/4	21	14	1/4	35	32	27	90	38	20	70	11	9	58	11	72	M10 x 1.5	7	18	7	M18 x 1.5	69	109	176
80	Up to 750	28	20	3/8	28	20	3/8	40	37	32	100	50	25	82	11	9	71	13	89	M10 x 1.5	10	22	7	M22 x 1.5	80	130	210
100	Up to 750	29	20	1/2	29	20	1/2	40	37	41	125	60	30	100	14	10	71	16	110	M12 x 1.75	10	26	8	M26 x 1.5	100	131	212

\* Foot brackets and plug bolts are installed when shipped from factory.

Note 1) ø20 and ø25 cylinders with an air cushion: M5 x 0.8

Note 2) Refer to the basic type (B)/CG5BA□S\* for the dimensions of air cushion needles.

### Integral clevis style (E): C□G5E<sub>A</sub><sup>N</sup>□S<sub>V</sub><sup>R</sup>

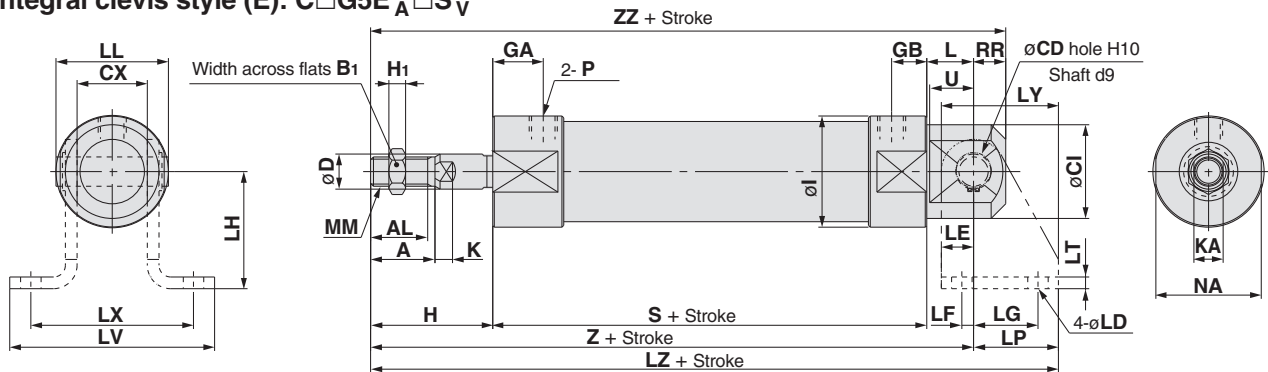

Bore size [mm]	Stroke range	Rc, NPT port			G port			A	AL	B <sub>1</sub>	CD (Hole)	CI	CX	D	H	H <sub>1</sub>	I	K	KA	L	MM	NA
		Standard	GA	GB	P	GA	GB	P														
20	Up to 200	18	12	1/8 <sup>(1)</sup>	18	12	M5 x 0.8	18	15.5	13	8 <sup>+0.058/0</sup>	25	16 <sup>0/-0.2</sup>	8	35	5	31	5	6	14	M8 x 1.25	29
25	Up to 300	18	12	1/8 <sup>(1)</sup>	18	12	M5 x 0.8	22	19.5	17	8 <sup>+0.058/0</sup>	27	16 <sup>0/-0.2</sup>	10	40	6	33	5.5	8	14	M10 x 1.25	29
32	Up to 300	18	12	1/8	18	12	1/8	22	19.5	17	10 <sup>+0.058/0</sup>	32	24 <sup>0/-0.2</sup>	12	40	6	38	5.5	10	16	M10 x 1.25	35.5
40	Up to 500	19	13	1/8	19	13	1/8	30	27	19	10 <sup>+0.058/0</sup>	40	24 <sup>0/-0.2</sup>	16	50	8	47	6	14	16	M14 x 1.5	44
50	Up to 600	21	14	1/4	21	14	1/4	35	32	27	14 <sup>+0.070/0</sup>	50	40 <sup>0/-0.2</sup>	20	58	11	58	7	18	22	M18 x 1.5	55
63	Up to 600	21	14	1/4	21	14	1/4	35	32	27	14 <sup>+0.070/0</sup>	60	40 <sup>0/-0.2</sup>	20	58	11	72	7	18	22	M18 x 1.5	69
80	Up to 750	28	20	3/8	28	20	3/8	40	37	32	22 <sup>+0.084/0</sup>	75	60 <sup>0/-0.3</sup>	25	71	13	89	10	22	33	M22 x 1.5	80
100	Up to 750	29	20	1/2	29	20	1/2	40	37	41	22 <sup>+0.084/0</sup>	90	60 <sup>0/-0.3</sup>	30	71	16	110	10	26	33	M26 x 1.5	100

Bore size [mm]	[mm]																		
	RR	S	U	Z	ZZ	Pivot bracket	CD (Shaft)	LD	LE	LF	LG	LH	LL	LP	LT	LV	LX	LY	LZ
20	9	83	13	132	141	CG-E020SUS	8 <sup>-0.040/-0.076</sup>	7	9	2	14	30	27.6	21	3	56.5	42	30	153
25	9	83	13	137	146	CG-E020SUS	8 <sup>-0.040/-0.076</sup>	7	9	2	14	30	27.6	21	3	56.5	42	30	158
32	11	85	15	141	152	CG-E032SUS	10 <sup>-0.040/-0.076</sup>	7	11	4	22	40	38.4	29	4	70.5	56	40	170
40	11	93	15	159	170	CG-E032SUS	10 <sup>-0.040/-0.076</sup>	7	11	4	22	40	38.4	29	4	70.5	56	40	188
50	15	109	21	189	204	CG-E050SUS	14 <sup>-0.050/-0.093</sup>	12	15	5	25	50	59.6	35	6	106.5	84	50	224
63	15	109	21	189	204	CG-E050SUS	14 <sup>-0.050/-0.093</sup>	12	15	5	25	50	59.6	35	6	106.5	84	50	224
80	23	130	32	234	257	CG-E080SUS	22 <sup>-0.065/-0.117</sup>	14	23	6	40	80	87.2	57	9	144.5	120	80	291
100	23	131	32	235	258	CG-E080SUS	22 <sup>-0.065/-0.117</sup>	14	23	6	40	80	87.2	57	9	144.5	120	80	292

\* Plug bolts are installed when shipped from factory.

\* Pivot bracket (with clevis pin and snap ring) are optional. (Not included.)

Note 1) ø20 and ø25 cylinders with an air cushion: M5 x 0.8

Note 2) Refer to the basic type (B)/CG5BA□S\* for the dimensions of air cushion needles.

# Series CG5-S

## Accessory Dimensions

### Single knuckle joint

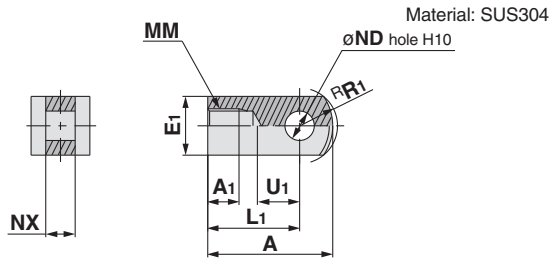

[mm]

Part no.	Applicable bore size [mm]	A	A <sub>1</sub>	E <sub>1</sub>	L <sub>1</sub>	MM	ND <sub>H10</sub>	NX	R <sub>1</sub>	U <sub>1</sub>
I-G02SUS	20	34	8.5	□16	25	M8 x 1.25	8 <sup>+0.058</sup> <sub>0</sub>	8 <sup>-0.2</sup> <sub>-0.4</sub>	10.3	11.5
I-G03SUS	25, 32	41	10.5	□20	30	M10 x 1.25	10 <sup>+0.058</sup> <sub>0</sub>	10 <sup>-0.2</sup> <sub>-0.4</sub>	12.8	14
I-G04SUS	40	42	14	□22	30	M14 x 1.5	10 <sup>+0.058</sup> <sub>0</sub>	18 <sup>-0.3</sup> <sub>-0.5</sub>	12	14
I-G05SUS	50, 63	56	18	□28	40	M18 x 1.5	14 <sup>+0.070</sup> <sub>0</sub>	22 <sup>-0.3</sup> <sub>-0.5</sub>	16	20
I-G08SUS	80	71	21	□38	50	M22 x 1.5	18 <sup>+0.070</sup> <sub>0</sub>	28 <sup>-0.3</sup> <sub>-0.5</sub>	21	27
I-G10SUS	100	79	21	□45	55	M26 x 1.5	22 <sup>+0.084</sup> <sub>0</sub>	32 <sup>-0.3</sup> <sub>-0.5</sub>	24	31

### Knuckle joint pin

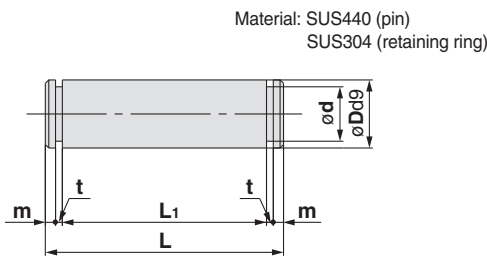

[mm]

Part no.	Applicable bore size [mm]	Dd <sub>9</sub>	d	L	L <sub>1</sub>	m	t	Applicable retaining ring
IY-G02SUS	20	8 <sup>-0.040</sup> <sub>-0.076</sub>	7.6	21	16.2	1.5	0.9	C type 8 for axis
IY-G03SUS	25, 32	10 <sup>-0.040</sup> <sub>-0.076</sub>	9.6	25.6	20.2	1.55	1.15	C type 10 for axis
IY-G04SUS	40	10 <sup>-0.040</sup> <sub>-0.076</sub>	9.6	41.6	36.2	1.55	1.15	C type 10 for axis
IY-G05SUS	50, 63	14 <sup>-0.050</sup> <sub>-0.093</sub>	13.4	50.6	44.2	2.05	1.15	C type 14 for axis
IY-G08SUS	80	18 <sup>-0.050</sup> <sub>-0.093</sub>	17	64	56.2	2.55	1.35	C type 18 for axis
IY-G10SUS	100	22 <sup>-0.065</sup> <sub>-0.117</sub>	21	72	64.2	2.55	1.35	C type 22 for axis

\* Retaining rings are included.

### Clevis pin

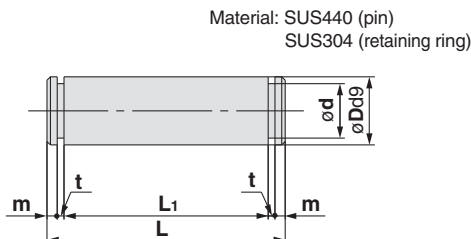

[mm]

Part no.	Applicable bore size [mm]	Dd <sub>9</sub>	d	L	L <sub>1</sub>	m	t	Applicable retaining ring
CD-E02SUS	20, 25	ø8 <sup>-0.040</sup> <sub>-0.076</sub>	7.6	27.6	22.8	1.5	0.9	C type 8 for axis
CD-E03SUS	32, 40	ø10 <sup>-0.040</sup> <sub>-0.076</sub>	9.6	38.4	33	1.55	1.15	C type 10 for axis
CD-E05SUS	50, 63	ø14 <sup>-0.050</sup> <sub>-0.093</sub>	13.4	59.6	53.2	2.05	1.15	C type 14 for axis
CD-E08SUS	80, 100	ø22 <sup>-0.065</sup> <sub>-0.117</sub>	21	87.2	79.4	2.55	1.35	C type 22 for axis

\* Retaining rings are included.

### Double knuckle joint

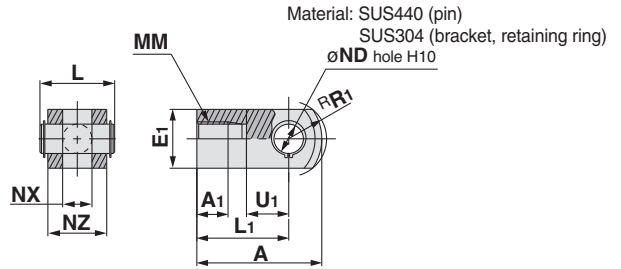

[mm]

Part no.	Applicable bore size [mm]	A	A <sub>1</sub>	E <sub>1</sub>	L	L <sub>1</sub>	MM	ND <sub>H10</sub>	NX	NZ	R <sub>1</sub>	U <sub>1</sub>	Applicable pin no.
Y-G02SUS	20	34	8.5	16	21	25	M8 x 1.25	8 <sup>+0.058</sup> <sub>0</sub>	8 <sup>+0.4</sup> <sub>+0.2</sub>	16	10.3	11.5	IY-G02SUS
Y-G03SUS	25, 32	41	10.5	20	25.6	30	M10 x 1.25	10 <sup>+0.058</sup> <sub>0</sub>	10 <sup>+0.4</sup> <sub>+0.2</sub>	20	12.8	14	IY-G03SUS
Y-G04SUS	40	42	16	22	41.6	30	M14 x 1.5	10 <sup>+0.058</sup> <sub>0</sub>	18 <sup>+0.5</sup> <sub>+0.3</sub>	36	12	14	IY-G04SUS
Y-G05SUS	50, 63	56	20	25	50.6	40	M18 x 1.5	14 <sup>+0.070</sup> <sub>0</sub>	22 <sup>+0.5</sup> <sub>+0.3</sub>	44	16	20	IY-G05SUS
Y-G08SUS	80	71	23	35	64	50	M22 x 1.5	18 <sup>+0.070</sup> <sub>0</sub>	28 <sup>+0.5</sup> <sub>+0.3</sub>	56	21	27	IY-G08SUS
Y-G10SUS	100	79	24	40	72	55	M26 x 1.5	22 <sup>+0.084</sup> <sub>0</sub>	32 <sup>+0.5</sup> <sub>+0.3</sub>	64	24	31	IY-G10SUS

\* Knuckle joint pins and retaining rings are included.

### Trunnion bracket

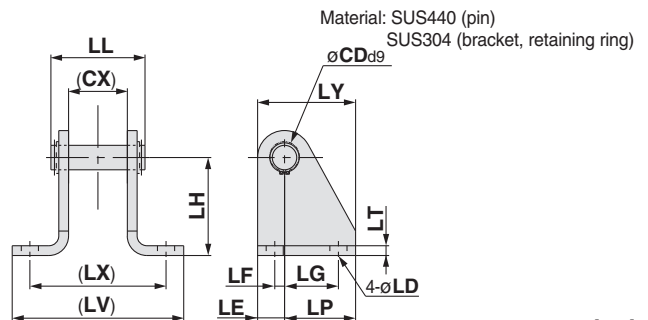

[mm]

Part no.	Applicable bore size [mm]	CD (retaining ring)	CX	LD	LE	LF	LG	LH	LL	LP	LT	LV	LX	LY
CG-E020SUS	20, 25	8 <sup>-0.040</sup> <sub>-0.076</sub>	16	7	9	2	14	30	27.6	21	3	56.5	42	30
CG-E032SUS	32, 40	10 <sup>-0.040</sup> <sub>-0.076</sub>	24	7	11	4	22	40	38.4	29	4	70.5	56	40
CG-E050SUS	50, 63	14 <sup>-0.050</sup> <sub>-0.093</sub>	40	12	15	5	25	50	59.6	35	6	106.5	84	50
CG-E080SUS	80, 100	22 <sup>-0.065</sup> <sub>-0.117</sub>	60	14	23	6	40	80	87.2	57	9	144.5	120	80

\* Clevis pins and retaining rings are included.

### Rod end nut

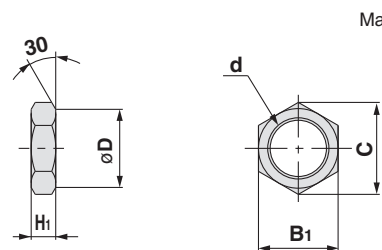

[mm]

Part no.	Applicable bore size [mm]	B <sub>1</sub>	C	D	d	H <sub>1</sub>
NT-02SUS	20	13	(15)	12.5	M8 x 1.25	5
NT-03SUS	25, 32	17	(19.6)	16.5	M10 x 1.25	6
NT-G04SUS	40	19	(21.9)	18	M14 x 1.5	8
NT-05SUS	50, 63	27	(31.2)	26	M18 x 1.5	11
NT-08SUS	80	32	(37.0)	31	M22 x 1.5	13
NT-10SUS	100	41	(47.3)	39	M26 x 1.5	16

# Series CJ5-S/CG5-S Auto Switch Mounting

## Proper Auto Switch Mounting Position (Detection at stroke end) and Its Mounting Height

Series CJ5-S  
D-M9□A(V)  
D-H7BA

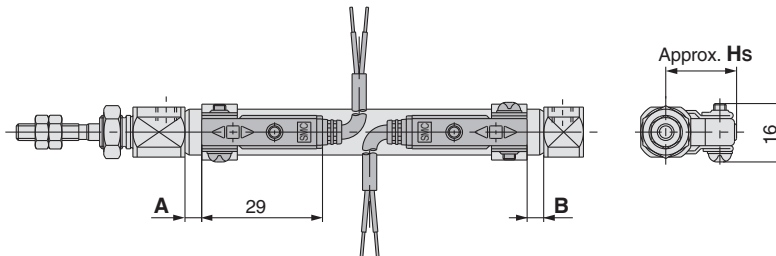

### Minimum strokes for auto switch mounting

Mounting bracket	Basic type, Foot type, Flange type, Clevis type		
Number of switches	1 pc. (Rod cover side)	2 pcs. (Different sides)	2 pcs. (Same side)
Mounting surface	Port surface 	Port surface 	Port surface 
Switch type			
Minimum stroke [mm]	10	15	60

### Auto Switch Mounting Bracket / Part No.

Auto switch model	Bore size [mm]	
	ø10	ø16
D-M9□A D-M9□AV	BJ6-010S Note 1)	BJ6-016S Note 1)
D-H7BA	BJ2-010S	BJ2-016S

\* With stainless steel mounting screws.

Note 1) Set part number which includes the auto switch mounting band (BJ2-□□□S) and the holder kit (BJ4-1/Switch bracket: White).

Note 2) For D-M9□A(V), avoid the indicator LED for mounting the switch bracket.

Series CG5-S  
D-G5BA

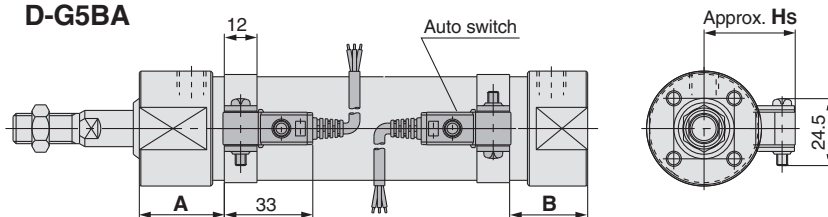

### Minimum strokes for auto switch mounting

Mounting bracket	Basic type, Foot type, Flange type, Clevis type		
Number of switches	1 pc. (Rod cover side)	2 pcs. (Different sides)	2 pcs. (Same side)
Mounting surface	Port surface 	Port surface 	Port surface 
Switch type			
Minimum stroke [mm]	10	15	75

### Auto Switch Mounting Bracket / Part No.

Auto switch model	Bore size [mm]							
	20	25	32	40	50	63	80	100
D-G5BA	NBA-088S	NBA-106S	BGS1-032S	BAF-04S	BAF-05S	BAF-06S	BAF-08S	BAF-10S

\* With stainless steel mounting screws.

### Operating Range

Auto switch model	Bore size [mm]	
	10	16
D-H7BA	5	5

\* Since this is a guideline including hysteresis, not meant to be guaranteed. (Assuming approximately ±30% dispersion) There may be the case to change substantially depending on an ambient environment.

### Proper Auto Switch Mounting Position and Its Mounting Height

Applicable bore size [mm]	Auto switch model	D-H7BA		
		A	B	Hs
10		0	0	17
16		0.5	0.5	20.5

Note) Adjust the auto switch after confirming the operating condition in the actual setting.

### Operating Range

Auto switch model	Bore size [mm]							
	20	25	32	40	50	63	80	100
D-G5BA	5	5	5.5	6	7	7.5	7.5	8

\* Since this is a guideline including hysteresis, not meant to be guaranteed. (Assuming approximately ±30% dispersion) There may be the case to change substantially depending on an ambient environment.

### Proper Auto Switch Mounting Position and Its Mounting Height

Applicable bore size [mm]	Auto switch model	D-G5BA		
		A	B	Hs
20		31.5	24	26
25		31.5	24	28.5
32		32.5	25	33
40		37	28	36.5
50		45.5	36	42
63		45.5	36	48.5
80		56	46	57.5
100		57	46	68

Note) Adjust the auto switch after confirming the operating condition in the actual setting.

# Simple Specials: -XA0 to XA30: Change of Rod End Shape

These changes are dealt with Simple Specials System.

Symbol

## 1 Change of Rod End Shape

-XA0 to XA30

### Applicable Series

Series	Action	Symbol for change of rod end shape	Note
CG5 Stainless steel cylinder	CG5-S Double acting, Single rod	XA0 to 30	

### ⚠ Precautions

- SMC will make appropriate arrangements if no dimension, tolerance, or finish instructions are given in the diagram.
- Standard dimensions marked with "\*" will be as follows to the rod diameter (D).  
Enter any special dimension you desire.  
 $D \leq 6 \rightarrow D - 1 \text{ mm}$ ,  $6 < D \leq 25 \rightarrow D - 2 \text{ mm}$ ,  $D > 25 \rightarrow D - 4 \text{ mm}$
- In the case of double rod type and single acting retraction type, enter the dimensions when the rod is retracted.

<p>Symbol: <b>A0</b></p>	<p>Symbol: <b>A1</b></p>	<p>Symbol: <b>A2</b></p>	<p>Symbol: <b>A3</b></p>
<p>Symbol: <b>A4</b></p>	<p>Symbol: <b>A5</b></p>	<p>Symbol: <b>A6</b></p>	<p>Symbol: <b>A7</b></p>
<p>Symbol: <b>A8</b></p>	<p>Symbol: <b>A9</b></p> <p>≅ C0.5 file chamfer</p>	<p>Symbol: <b>A10</b></p>	<p>Symbol: <b>A11</b></p>
<p>Symbol: <b>A12</b></p>	<p>Symbol: <b>A13</b></p>	<p>Symbol: <b>A14</b></p>	<p>Symbol: <b>A15</b></p>

# Simple Specials: Change of Rod End Shape

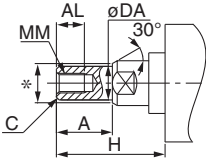
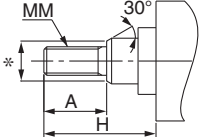
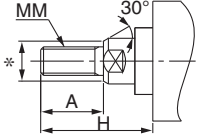
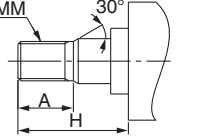
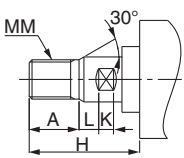
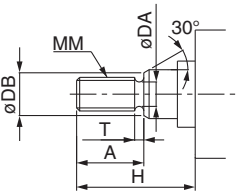
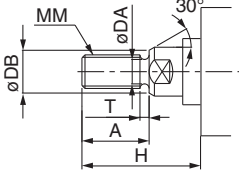
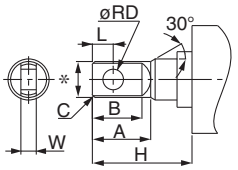
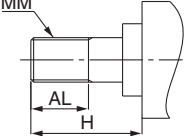
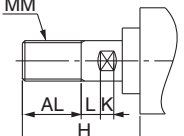
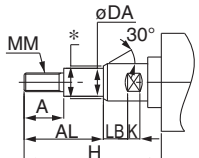
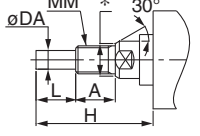
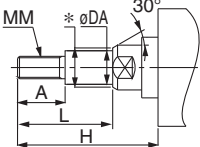
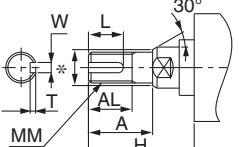
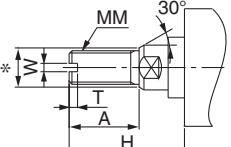
<p>Symbol: <b>A16</b></p> 	<p>Symbol: <b>A17</b></p> 	<p>Symbol: <b>A18</b></p> 	<p>Symbol: <b>A19</b></p> 
<p>Symbol: <b>A20</b></p> 	<p>Symbol: <b>A21</b></p> 	<p>Symbol: <b>A22</b></p> 	<p>Symbol: <b>A23</b></p> 
<p>Symbol: <b>A24</b></p> 	<p>Symbol: <b>A25</b></p> 	<p>Symbol: <b>A26</b></p> 	<p>Symbol: <b>A27</b></p> 
<p>Symbol: <b>A28</b></p> 	<p>Symbol: <b>A29</b></p> 	<p>Symbol: <b>A30</b></p> 	

# Made to Order Common Specifications: -XB6: Heat Resistant Cylinder (−10 to 150°C)



## 2 Heat Resistant Cylinder (−10 to 150°C)

Symbol  
-XB6

Air cylinder which changed the seal material and grease, so that it could be used even at higher temperature up to 150 from −10°C.

### Applicable Series

Series	Description	Model	Action	Note
CG5	Stainless cylinder	CG5	Double acting, Single rod	Except with auto switch. Without a bumper for cylinders with a rubber bumper (Grease for non-food is used.)

### How to Order

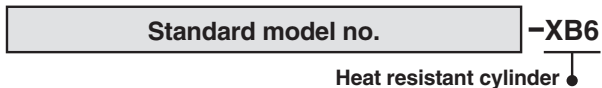

### Specifications

Ambient temperature range	−10 to 150°C
Seals materials	Fluororubber
Grease	Heat resistant grease
Specifications other than above and external dimensions	Same as standard type

- Note 1) Operate without lubrication from a pneumatic system lubricator.  
 Note 2) Please contact SMC for details on the maintenance intervals for this cylinder, which differ from those of the standard cylinder.  
 Note 3) In principle, it is impossible to make built-in magnet type and the one with auto switch. But, as for the one with auto switch, and the heat resistant cylinder with heat resistant auto switch, since it will be differed depending on the series, please contact SMC.  
 Note 4) Piston speed is ranged from 50 to 500 mm/s.

### ⚠ Warning Precautions

Be aware that smoking cigarettes, etc. after your hands have come into contact with the grease used in this cylinder can create a gas that is hazardous to humans.

# Technical Data

## Chemical Resistance Table

- ◎ : No influence or almost no influence  
 ○ : Some influence, but operational depending on conditions  
 △ : Avoid use if possible  
 × : Substantial influence, not suitable for use  
 — : Not tested

Chemical Resistance Table

Parts		Body		Seal		Water resistant auto switch	
Material		Stainless steel	Aluminum*	Nitrile rubber	Fluororubber	Resin casing	Lead wire
Chemical (Concentration weight %, Temperature °C)		Stainless steel 304	Al	NBR (-10 to 60°C)	FKM (-40 to 150°C)	PBT (-10 to 60°C)	PVC (-10 to 60°C)
Symbol							
Inorganic salt	1	Hydrochloric acid (20%, Room temperature)	×	×	○	◎	○
	2	Chromic acid (25%, 70°C)	○	×	×	◎	○
	3	Boric acid	○	×	◎	◎	○
	4	Sulfuric acid (30%, Room temperature)	×	×	◎	◎	○
	5	Phosphoric acid (50%, Room temperature)	○	×	◎	◎	○
Inorganic alkali	6	Ammonium hydroxide (28%)	○	○	○	×	◎
	7	Sodium hydroxide (30%, Room temperature)	◎	×	◎	△	×
	8	Calcium hydroxide	△	×	◎	◎	◎
Organic solvent	9	Magnesium hydroxide	○	○	◎	◎	◎
	10	Acetylene	◎	◎	◎	◎	◎
	11	Formic acid (25%, Room temperature)	○	△	×	△	△
	12	Citric acid	△	×	◎	◎	△
	13	Acetic acid (10%, Room temperature)	◎	△	△	○	◎
Others (oil, gas, etc.)	14	Lactic acid (5%, 20°C)	○	×	◎	◎	○
	15	Linseed oil	◎	○	◎	◎	△
	16	Potassium chloride	○	△	◎	◎	◎
	17	Calcium chloride	○	◎	◎	◎	◎
	18	Mineral oil	◎	◎	◎	◎	△
	19	Sodium hypochlorite (2%, Room temperature)	○	×	×	◎	◎
	20	Sodium chloride	○	—	◎	◎	◎
	21	Carbon dioxide	◎	◎	◎	◎	◎
	22	Natural gas	◎	◎	◎	◎	◎
	23	Boric acid	○	×	◎	◎	○

\* Unless noted otherwise, the solution concentration is in a saturated state.

\* Chemical resistance is a guide that applies only to the stainless steel cylinder parts, and does not guarantee the performance of air cylinders (auto switches). Be sure to perform a verification test before operating.

\* ) Reference data



# Stainless Steel Cylinder Series CJ5-S/CG5-S Specific Product Precautions 1

Be sure to read before handling.

Refer to safety instructions and actuator common precautions.

## Caution on Design

### Warning

#### 1. Note the weight of the stainless steel products.

Since the weight of stainless steel cylinders is approximately 1.5 to 3 times heavier than the standard products (with aluminum body), be careful when calculating weight estimates. Also, when mounting the cylinder on equipment where vibration is expected, avoid using single side brackets such as the flange type, and use double side brackets such as the foot type instead.

### Caution

#### 1. Adjust the speed control for the environment in which it will be used.

Speed adjustment may be changed depending on the environment.

#### 2. Dust may accumulate on this product's mounting screws and brackets in some operating conditions.

Measures must be applied depending on the operating conditions when mounting.

## Selection

### Warning

#### 1. Generally, use nitrile rubber (NBR) seals with liquids that do not contain chlorine and sulphur, and use fluoro rubber (FKM) seals with liquids that contain chlorine and sulphur.

However, depending on the type and the brand of liquid (such as cleaning solvent) that splashes on the cylinder, the operating life of seals may be reduced dramatically. In cases where special additives are used, or where liquid caused trouble with the conventional nitrile or fluoro rubber seals in the past, request an investigation or set up a test period for the use of the seals.

#### 2. Even the fluoro rubber specification may not be applicable depending on the type of chemicals and the operating temperature. Therefore, be sure to verify the seal's applicability before use.

## Mounting

### Warning

#### 1. Do not rotate the cover.

If a cover is rotated when installing a cylinder or screwing a fitting into the port, it is likely to damage the junction part with cover.

#### 2. When using pins, apply grease, etc., in order to prevent them from degrading of shape and rusting.

## Operating Precautions

### Warning

#### 1. For details about operating precautions, refer to Series CJ2 and Series CG1.

### Caution

#### 1. If cleaning the rotating part, grease may leak out, which shortens product service life. Thus, cleaning must be as infrequent as possible.

#### 2. If excess water gets into mounting holes, unwanted bacteria may reproduce. Plug them with plug bolts or external covers to avoid this.

## Operating Environment

### Warning

#### 1. Fully consider the compatibility of stainless steel.

The corrosion resistance of stainless steel is not effective against all media and corrosive environments. Corrosion proceeds rapidly with strong hydrochloric acid, hydrofluoric acid, and high temperature ammonium gas, etc. Therefore its compatibility to the environment must be considered carefully.

#### 2. Do not operate cylinders with auto switches in environments where oil and chemicals are used.

Contact SMC when operating in environments with coolants, cleaning solvents, various oils or chemicals, as it may cause adverse effects (faulty insulation, malfunction due to swelling of the potting resin, and hardening of lead wires, etc) to auto switches even in a short period of time. Even with the fluoro rubber seal specification, the auto switch related parts (switch body, mounting bracket, and built-in magnet) are identical to the standard specifications. Therefore, consult SMC regarding the cylinder's compatibility (such as chemical resistance) with an environment (chemicals, etc.) before operating.

#### 3. Do not immerse the cylinder in water or chemicals.

When the cylinder is operated in a condition with water pressure, the fluid leaks into the cylinder in the early stages. In the worst case, the fluid may back flow inside the piping and damage the solenoid valve.

### Caution

#### 1. Avoid installing and using a cylinder inside a food zone.

<Not installable>

Food zone ..... An environment where food which will be sold as merchandize, directly touches the cylinder's components.

<Installable>

Splash zone ..... An environment where food which will not be sold as merchandize, directly touches the cylinder's components.

Non-food zone ..... An environment where there is no contact with food.

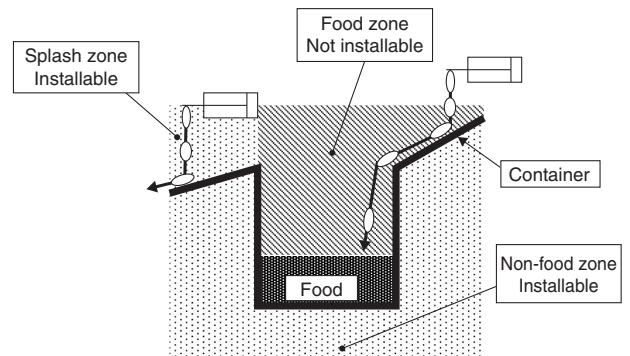

#### 2. When cleaning solvent or chemicals splashes on a cylinder, the service life may be extremely shortened. Please contact SMC for details.

#### 3. When cleaning cylinders with steam, do it as quickly as possible, keeping the cylinder's temperature range in mind.

#### 4. When cleaning cylinders with a brush, etc., do not apply excessive force to the weaker parts, such as auto switch lead wire, etc.



# Stainless Steel Cylinder Series CJ5-S/CG5-S Specific Product Precautions 2

Be sure to read before handling.

Refer to safety instructions and actuator common precautions.

## Maintenance

### Warning

#### 1. If this cylinder is lubricated, it may cause malfunctions.

If grease other than designated is used, it may also cause malfunctions.

- Order with the following part number when only the grease for maintenance is needed.

Grease pack part number for stainless steel cylinders

Grease for food processing machines: GR-R-010 (10 g)

#### 2. Do not wipe grease attached to the rotating part of the air cylinder.

If grease attached to the rotating part is forcibly wiped off, it may cause malfunctions.

If the cylinder is operated for a long period of time, the rotating part may become black. In such cases, wipe the grease attached to the rotating part and reapply fresh grease to enable the cylinder to operate for a long period of time.

(Wipe the grease with water. Using alcohol or solvents may damage seals.)

### Precautions for series CG5-S

#### 1. Sealant\* is used on the threads of the connecting sections of the cover and the cylinder tube for air-tight construction. When disassembling the cylinder, the old sealant must be completely removed, and new sealant must be applied before re-assembling.



\* Loctite 542 (medium strength) or equivalent

#### 2. $\varnothing 50$ or larger bore size cylinders cannot be disassembled.

When disassembling cylinders with bore sizes of  $\varnothing 20$  through  $\varnothing 40$ , grip the double flat part of either the head cover or the rod cover with a vise and loosen the other side with a wrench or a monkey wrench, etc., and then remove the cover. When re-tightening, tighten approximately 2 degrees more than the original position. (Cylinders with  $\varnothing 50$  or larger bore sizes are tightened with a large tightening torque and cannot be disassembled. Contact SMC when disassembly is required.)

## Safety Instructions

These safety instructions are intended to prevent hazardous situations and/or equipment damage. These instructions indicate the level of potential hazard with the labels of “Caution,” “Warning” or “Danger.” They are all important notes for safety and must be followed in addition to International Standards (ISO/IEC)\*1), and other safety regulations.

-  **Caution:** Caution indicates a hazard with a low level of risk which, if not avoided, could result in minor or moderate injury.
-  **Warning:** Warning indicates a hazard with a medium level of risk which, if not avoided, could result in death or serious injury.
-  **Danger:** Danger indicates a hazard with a high level of risk which, if not avoided, will result in death or serious injury.

\*1) ISO 4414: Pneumatic fluid power – General rules relating to systems.  
ISO 4413: Hydraulic fluid power – General rules relating to systems.  
IEC 60204-1: Safety of machinery – Electrical equipment of machines.  
(Part 1: General requirements)  
ISO 10218-1: Manipulating industrial robots - Safety.  
etc.

### Warning

#### 1. The compatibility of the product is the responsibility of the person who designs the equipment or decides its specifications.

Since the product specified here is used under various operating conditions, its compatibility with specific equipment must be decided by the person who designs the equipment or decides its specifications based on necessary analysis and test results. The expected performance and safety assurance of the equipment will be the responsibility of the person who has determined its compatibility with the product. This person should also continuously review all specifications of the product referring to its latest catalogue information, with a view to giving due consideration to any possibility of equipment failure when configuring the equipment.

#### 2. Only personnel with appropriate training should operate machinery and equipment.

The product specified here may become unsafe if handled incorrectly. The assembly, operation and maintenance of machines or equipment including our products must be performed by an operator who is appropriately trained and experienced.

#### 3. Do not service or attempt to remove product and machinery/equipment until safety is confirmed.

1. The inspection and maintenance of machinery/equipment should only be performed after measures to prevent falling or runaway of the driven objects have been confirmed.
2. When the product is to be removed, confirm that the safety measures as mentioned above are implemented and the power from any appropriate source is cut, and read and understand the specific product precautions of all relevant products carefully.
3. Before machinery/equipment is restarted, take measures to prevent unexpected operation and malfunction.

#### 4. Contact SMC beforehand and take special consideration of safety measures if the product is to be used in any of the following conditions.

1. Conditions and environments outside of the given specifications, or use outdoors or in a place exposed to direct sunlight.
2. Installation on equipment in conjunction with atomic energy, railways, air navigation, space, shipping, vehicles, military, medical treatment, combustion and recreation, or equipment in contact with food and beverages, emergency stop circuits, clutch and brake circuits in press applications, safety equipment or other applications unsuitable for the standard specifications described in the product catalogue.
3. An application which could have negative effects on people, property, or animals requiring special safety analysis.
4. Use in an interlock circuit, which requires the provision of double interlock for possible failure by using a mechanical protective function, and periodical checks to confirm proper operation.

## Limited warranty and Disclaimer/ Compliance Requirements

The product used is subject to the following “Limited warranty and Disclaimer” and “Compliance Requirements”.  
Read and accept them before using the product.

### Limited warranty and Disclaimer

1. The warranty period of the product is 1 year in service or 1.5 years after the product is delivered, whichever is first.\*2)  
Also, the product may have specified durability, running distance or replacement parts. Please consult your nearest sales branch.
2. For any failure or damage reported within the warranty period which is clearly our responsibility, a replacement product or necessary parts will be provided. This limited warranty applies only to our product independently, and not to any other damage incurred due to the failure of the product.
3. Prior to using SMC products, please read and understand the warranty terms and disclaimers noted in the specified catalogue for the particular products.

#### \*2) Vacuum pads are excluded from this 1 year warranty.

A vacuum pad is a consumable part, so it is warranted for a year after it is delivered. Also, even within the warranty period, the wear of a product due to the use of the vacuum pad or failure due to the deterioration of rubber material are not covered by the limited warranty.

### Compliance Requirements

1. The use of SMC products with production equipment for the manufacture of weapons of mass destruction (WMD) or any other weapon is strictly prohibited.
2. The exports of SMC products or technology from one country to another are governed by the relevant security laws and regulations of the countries involved in the transaction. Prior to the shipment of a SMC product to another country, assure that all local rules governing that export are known and followed.

### Caution

#### 1. The product is provided for use in manufacturing industries.

The product herein described is basically provided for peaceful use in manufacturing industries.

If considering using the product in other industries, consult SMC beforehand and exchange specifications or a contract if necessary.

If anything is unclear, contact your nearest sales branch.

### Caution

#### SMC products are not intended for use as instruments for legal metrology.

Measurement instruments that SMC manufactures or sells have not been qualified by type approval tests relevant to the metrology (measurement) laws of each country. Therefore, SMC products cannot be used for business or certification ordained by the metrology (measurement) laws of each country.

## Safety Instructions

Be sure to read “Handling Precautions for SMC Products” (M-E03-3) before using.