



















2/2 & 3/2 Solenoid operated valves

Operation	Series	Page no.	Function	Body material	Solenoids	
					IP Protection class	IP65 (with connector)
			2/2 3/2	Stainless steel Brass Grey cast iron Plastic resin PVDF		
Direct solenoid actuated	 Buschjost 82080 0 ... 7 bar G $\frac{1}{4}$, G $\frac{3}{8}$ NC ≤13,83 l/min	30	●		●	 8050, 8051
	 Herion 91000 0 ... 300 bar G $\frac{1}{2}$... G $\frac{1}{2}$ NC / NO ≤1440 l/min	32	●	● ●		 0700 0800 9300 1001
	 Herion 95000 0 ... 40 bar G $\frac{1}{4}$, G $\frac{1}{2}$, $\frac{1}{4}$ NPT NC / NO ≤1700 l/min	34	●		●	 0200, 0246, 3206, 3204 0800, 0827, 3803, 3805 0700, 3703
	 Herion 95100 0 ... 50 bar G $\frac{1}{2}$, G $\frac{1}{4}$, $\frac{1}{4}$ NPT NC ≤520 l/min	36	●		●	 0200, 0246, 3206, 3204 0800, 0827, 3803, 3805 0700, 3703
	 Herion 21023 / 21025 0 ... 10 bar G $\frac{1}{4}$, G $\frac{1}{2}$ NC ≤750 l/min	44	●	● ●		 0800, 3803
	 Herion 21000 0 ... 50 bar G $\frac{1}{4}$... G $\frac{1}{2}$ NC ≤1000 l/min	46	●		●	 1300, 1301 1500, 1501
	 Herion 23200 0 ... 25 bar G $\frac{1}{2}$... G2 NC/NO ≤16500 l/min	48	●	● ● ●		 1300, 1301 1500, 1501 1600, 1601 1700, 1701
	 Webber Cartridge valve 0 ... 10 bar NC ≤125 l/min	52	● ●			
	 Webber Excel 22 Dual control 10 bar NC ≤29 l/min	53	●			
	 Webber Ink jet valve -0.5 ... 4.5 bar NC, Changeover ≤100 c.c./min	54	● ●			●
 Webber Base ported mini valves 0 ... 5 bar NC/NO G $\frac{1}{4}$ ≤90 l/min	56	●			●	

Explosion proof class
Zones 21, 22
II 2 G
EEx me
**EEx me
IP65**
Zones 2, 22
II 3 GD
**EEx nA
IP65**
Zones 1, 2, 21, 22
II 2 G / II 2 D
**EEx d
IP 66**
**EEx m
IP 66**
**EEx me
IP 66**
**EEx md
EEx me
IP 66**

8042

 3216, 3217,
3218, 3219

 3817, 3818,
3819

 0290, 0291,
0292, 0293

 4210/1, 4220/1, 4230/1,
4270/1, 4280/1

 4610/1/2/3, 4620/1/2/3, 4630/1/2/3,
4670/1/2/3, 4680/1/2/3

 3216, 3217,
3218, 3219

 3817, 3818,
3819

 0290, 0291,
0292, 0293

 4210/1, 4220/1, 4230/1,
4270/1, 4280/1

 4610/1/2/3, 4620/1/2/3, 4630/1/2/3,
4670/1/2/3, 4680/1/2/3

4270, 4271



4670, 4671, 4672, 4673



1440, 1441



1570, 1571



1440, 1441



1570, 1571























1680, 1681



1480, 1481

2/2 & 3/2 Solenoid operated valves

Operation	Series	Function	Body material	Solenoids
	Page no.	2/2 3/2	Stainless steel Brass Zinc alloy Plastic resin	IP Protection class IP65 (with connector)
Direct solenoid actuated	 Webber water management valves 0 ... 10 bar NC ≤4,5 l/min 58	●	●	
	 Webber Excel 22 0 ... 10 bar NC G½ ≤77 l/min 60	●	●	
	 Webber Excel 22 ½" BSP 0 ... 12 bar NC/NO G½ ≤152 l/min 62	● ●	●	
	 Webber Excel 22 Hosetail 0 ... 10 bar NC ≤113 l/min 64	● ●	●	
	 Webber Excel 32 Sub-base mounted 0 ... 16 bar NC/NO ≤150 l/min 66	● ●	●	
	 Webber Excel 32 In-line 0 ... 16 bar NC/NO G½, G¼ ≤260 l/min 67	● ●	● ●	
Indirect solenoid actuated	 Herion 91000 0 ... 300 bar G½ ... G½ NC / NO ≤1440 l/min 32	● ●	● ●	 0700  0800  9300  1001
	 Buschjost 82400 / 82410 0 ... 16 bar G¼ ... G2, ¼ ... 2 NPT NC ≤683 l/min 68	●	●	 9101  9151
	 Buschjost 85300 / 85310 0,5 ... 40 bar G¼ ... G2, ¼ ... 2 NPT NC ≤716 l/min 70	●	●	 9151
	 Buschjost 83620 / 83630 0,1 ... 10 bar G¼ ... G¾ NC ≤25,0 l/min 72	●	●	 8001
	 Buschjost 82470 0,1 ... 10 bar G¼ ... G1 NC ≤141 l/min 74	●	●	 9101

Explosion proof class

Zones 1, 21

II 2 GD

EEx m





















IP67



9136



2/2 & 3/2 Solenoid operated valves

Operation	Series	Function	Body material	Solenoids
	Page no.	2/2	Stainless steel Brass	IP Protection class IP65 (with connector)
Indirect solenoid actuated	 Buschjost 85320 1 ... 25 bar G1/4 ... G1 1/4 ... 1 NPT NC ≤175 l/min 76	●	●	 9152
	 Buschjost 82730 / 82740 0,1 ... 16 bar G1/4 ... G1 1/4 ... 1 NPT NC ≤158 l/min 78	●	●	 9101, 9104
Solenoid actuated with forced lifting	 Buschjost 82540 / 82640 0 ... 10 bar G1/4 ... G2 1/4 ... 2 NPT NC ≤683 l/min 80	●	●	 9151, 9154 9401, 9404 8401, 8404
	 Buschjost 82530 / 82630 0 ... 10 bar G1/4 ... G1/2 1/4 ... 1/2 NPT NC ≤28,3 l/min 82	●	●	 8001
	 Buschjost 85040 / 85050 0 ... 25 bar G3/8 ... G1 3/8 ... 1 NPT NC ≤217 l/min 84	●	●	 8301, 8304 8401, 8404
	 Buschjost 85140 / 84140 0 ... 16 bar Flange PN 16 NC ≤2400 l/min 86	●	●	 8301, 8304 8401, 8404 9501, 9504
	 Buschjost 82560 / 82570 0 ... 10 bar G1/4 ... G1/2 1/4 ... 1/2 NPT NC ≤28,3 l/min 88	●	●	 9748, 9749
	 Buschjost 82360 / 82460 0 ... 10 bar G1/4 ... G1 1/4 ... 1 NPT NC ≤133 l/min 90	●	●	 8302, 8306
	 Buschjost 85700 / 85710 0 ... 25 bar G1/4 ... G2 1/4 ... 2 NPT NC ≤717 l/min 92	●	●	 9401, 9404 8401, 8404
	 Buschjost 85720 / 85730 0 ... 16 bar G1/4 ... G2 1/4 ... 2 NPT NC ≤683 l/min 94	●	●	 9402, 9406 8402, 8406

Explosion proof class

Zones 1, 21

II 2 GD

**EEx me
IP65**

**EEx m
IP67**

**EEx de
IP65**

**EEx d
IP65**



9136



8041



8341



8441



8900



8920



8341



8441



9540

2/2 & 3/2 Solenoid operated valves

Buschjost 82080 Series

Direct solenoid actuated angle seat valves

3 to 8 mm orifice (ND)

2/2, NC, G $\frac{1}{4}$ and G $\frac{3}{8}$

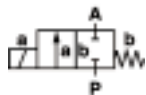

High fluid compatibility thanks to optimum materials matching

Suitable for vacuum

For heavy-duty industrial applications

Hermetic seal between fluid and actuator

Compact design

For highly contaminated fluids

Technical data

Medium:

Aggressive gases and liquids

Viscosity:

80 mm²/s (cSt) max.

Flow direction:

Fixed

Mounting:

Optional, but preferably with solenoid vertical

Fluid temperature:

-10°C to +110°C max.

Ambient temperature:

-10°C to +50°C max.

Consult our Technical Service for use below +2°C

Materials

Body: PVDF

Seat seal: EPDM

Internal parts: PTFE bellows

For contaminated fluids installation of an upstream filter is recommended.



Orifice (mm)	Port size	Operating pressure (bar)	kv value m ³ /h*	Total weight (kg)	Model
3,0	G 1/4	0 ... 7	0,23	0,3	820800xxxx*****
4,5	G 1/4	0 ... 5	0,42	0,3	8208060xxxx*****
6,0	G 1/4	0 ... 2	0,62	0,3	8208070xxxx*****
8,0	G 1/4	0 ... 1	0,83	0,3	8208080xxxx*****
3,0	G 3/8	0 ... 7	0,23	0,3	8208100xxxx*****
4,5	G 3/8	0 ... 5	0,42	0,3	8208160xxxx*****
6,0	G 3/8	0 ... 2	0,62	0,3	8208170xxxx*****
8,0	G 3/8	0 ... 1	0,83	0,3	8208180xxxx*****

xxxx Insert solenoid codes from table below. ***** Insert voltage codes from table below

* Cv (US) ≈ kv x 1,2

Options selector

8208X ★ ★ ★ ★ ★ ★ ★ ★ ★ ★

Alternative version	Substitute	Voltage	Substitute
Seat seal material FPM, preferably for fuels and oils, max. fluid temperature +110°C	03	24 V d.c.	02400
Seat and soft seal material PTFE, max. fluid temperature +110°C	06	24 V a.c., 40 to 60 Hz	02449
		110 V a.c., 40 to 60 Hz	11049
		230 V a.c., 40 to 60 Hz	23049
		Other voltages on request	
Solenoid	Substitute		
d.c.	8050		
a.c.	8051		
EEx me II T3	8042		



Buschjost 82080 Series

Direct solenoid actuated angle seat valves

3 to 8 mm orifice (ND)

2/2, NC, G $\frac{1}{4}$ and G $\frac{3}{8}$

Electrical details for solenoid operators

	Power consumption		Voltage		Category	Protection class	Temperatures °C		Electrical connection	kg	Solenoid drawing no. #	Circuit diagram#		Model
	24 V d.c. (W)	230 V a.c. (VA)	24 V d.c. (mA)	230 V a.c. (mA)			Fluid*	Ambient**				d.c.	a.c.	
	12	20/16	500	70	–	IP 65	+100 max.	-25 ... +50	DIN EN 175301-803	0,22	16	1	1	8050
	12	13 VA/12 W	500	59	–	IP 65	+110 max.	-25 ... +50	DIN EN 175301-803	0,22	16	–	2	8051
	12	13 VA/12 W	500	59	II 2 G D	EEx me II T3, IP 65	+80 max.	-20 ... +40	Connector body	0,30	23	2	6	8042

* The maximum temperature depends on the valve type

** The maximum temperature may be higher, depending on the application.

Version as per VDE 0580, duty cycle 100%.

Power consumption with coil temperature of +20°C. With the solenoid coil at operating temperature (d.c.), the power consumption is up to 30% lower for physical reasons

Cable clamping range 5 to 10 mm

For solenoid dimensional drawings and circuit diagrams, see page 97

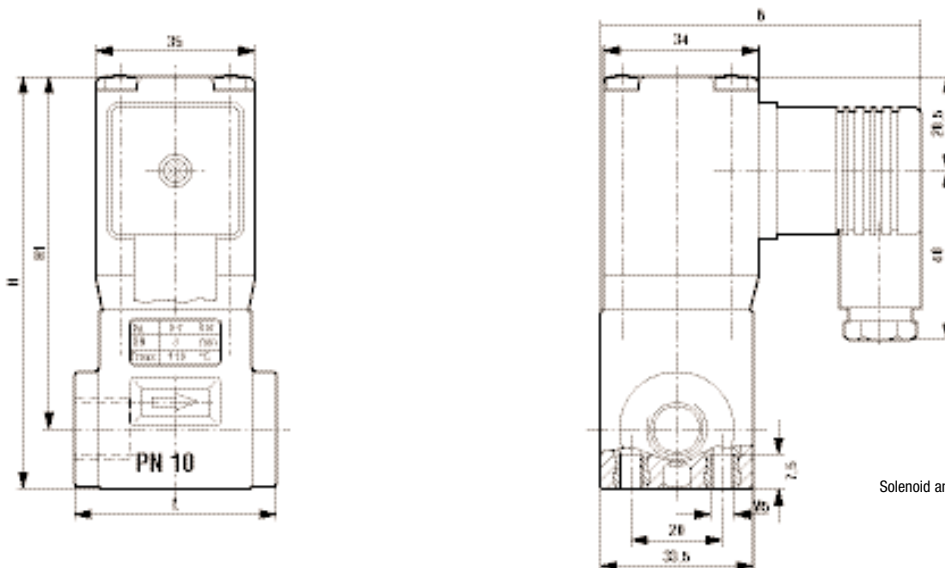

Solenoid and device socket can be turned through 4 x 90°

Model	Connection	B	H	H1	L
82080XX 8050	G 1/4	70	90	77	44
82080XX 8051	G 1/4	70	90	77	44
82081XX 8050	G 3/8	70	90	77	44
82081XX 8051	G 3/8	70	90	77	44

Herion 91000 Series

Direct and indirect solenoid actuated poppet valves

1,5 to 10 mm orifice (ND)

2/2, NC/NO, G $\frac{1}{8}$ to G $\frac{1}{2}$

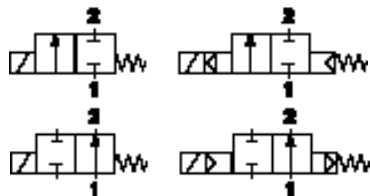
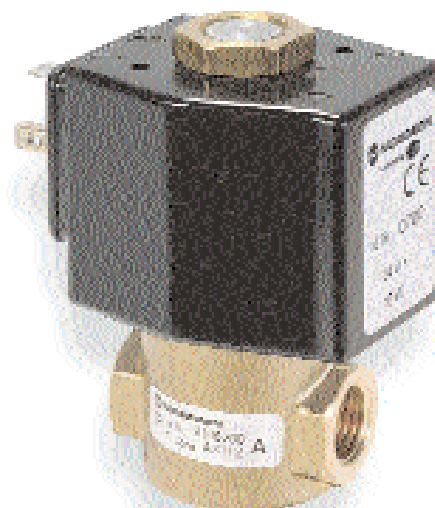

High switchable Δp

Hermetically sealed poppet valves

Excellent repeatability of switching times

Technical data

Medium:

For neutral gaseous and liquid fluids

Operating pressure:

0 to 300 bar / 1 to 250 bar

Flow direction:

Fixed

Mounting position:

Optional, preferably with solenoid on top

Fluid temperature:

-10 to +60 °C AU (polyurethane)

-40 to +80 °C POM (Delrin)

-40 to +120 °C PVDF / PI

With minus temperatures, use conditioned dry air. If installed in the open protect all connections against the penetration of moisture

Ambient temperature:

Depending on solenoid system

-10, -25, -40 to +55, +70,

+100 °C

Consult our Technical Service for use below +2°C

Orifice (mm)	Port size	Function	Operating pressure (bar)		kv value m ³ /h*	Materials Housing	Seat seal	kg	Drawing no.	Model	
			Min.	Fluid max. Gaseous Liquid							
1,5	G 1/4	NC	0	80	80	0,068	Brass	AU	0,55	1	9106200.0700***** 2)
1	G 1/4	NC	0	200	200	0,035	S/steel	POM	0,6	3	9106250.0800***** 1)
1,2	G 1/4	NC	0	300	300	0,035	S/steel	PI	1,2	4	9922202.1001***** 1)
1,8	G 1/4	NC	0	175	175	0,07	S/steel	PI	1,2	4	9922203.1001***** 1)
1	G 1/4	NC	0	80	-	0,035	Brass	AU	0,55	2	9106212.0700***** 2)
6	G 1/4	NC	1	-	80	0,57	Brass	POM	0,6	5	9107200.0700*****
6	G 1/4	NC	1	80	-	0,57	Brass	POM	0,6	5	9107400.0700*****
10	G 1/2	NC	1	-	80	1,44	Brass	POM	0,76	6	9107300.0700*****
10	G 1/2	NC	1	80	-	1,44	Brass	POM	0,76	6	9107500.0700*****
10	G 1/2	NC	1	-	130	1,40	S/steel	PVDF	0,76	7	9107318.0800*****
10	G 1/2	NC	1	130	-	1,40	S/steel	PVDF	0,76	7	9107525.0800*****
10	G 1/2	NC	1	-	170	1,40	S/steel	PVDF	0,76	7	9107318.9300*****
10	G 1/2	NC	1	170	-	1,40	S/steel	PVDF	0,76	7	9107525.9300*****
6	G 1/4	NO	10	-	80	0,57	Brass	POM	0,6	5	9107212.0700*****
6	G 1/4	NO	10	80	-	0,57	Brass	POM	0,6	5	9107412.0700*****
10	G 1/2	NO	10	-	80	1,44	Brass	POM	0,76	6	9107312.0700*****
10	G 1/2	NO	10	80	-	1,44	Brass	POM	0,76	6	9107512.0700*****

***** Insert voltage codes from table below

* Cv (US) = kv x 1,2

1) Suitable for d.c. only; for a.c. use connector with rectifier, model no. 0663303.

2) Not suitable for water.

Materials

Housing: brass, stainless steel

1.4305

Seat seal: see fluid temperature

Inner parts: brass, stainless steel

1.4305

For contaminated fluids

installation of an upstream filter is recommended.

Options selector

910XXXX *****

992220X *****

Solenoid	Voltage	Substitute
See solenoid tables	24 V d.c.	02400
	24 V a.c.	02450
	110 V a.c.	11050
	230 V a.c.	23050

Other voltages on request

Accessories

Connectors



0570275

Herion 95000 Series

Direct solenoid actuated poppet valves

1,5 to 6 mm orifice (ND)

2/2, NC/NO, G1/4, G1/2, 1/4 NPT



Working from 0 bar up

Short switching times

Suited for fine vacuum 1.33-10⁻³ mbar

Assembled oil and grease-free

For a.c. solenoid systems with integrated rectifier (40 to 60 Hz)

These solenoids are ATEX and FM, CSA, XP approved

Technical data

Medium:

Neutral gaseous and liquid fluids

Operating pressure:

0 to 40 bar

Flow direction:

Fixed

Mounting position:

Optional, preferably with solenoid on top

Fluid temperature:

-25 to +80°C NBR (Perbunan)

-10 to +120°C FPM (Viton)*

-40 to +140°C EPDM

-50 to +180°C PTFE (Teflon)

-10 to +180°C FFKM (Kalrez)

* For water +90°C

Ambient temperature:

Depending on solenoid system

-25 to +80°C

Consult our Technical Service for use below +2°C

Materials

Housing: Brass

Seal: NBR (Perbunan)

Inner parts: brass, steel 1.4104/430F

Alternative models

Solenoid with low power consumption

Solenoid for higher temperatures

Solenoid in protection class EEx m

Solenoid for outdoor application

Solenoid with FM-/CSA-certification

(NEMA 4, 4X, 7 and 9)

Operating pressure to 50 bar

For contaminated fluids installation of an upstream filter is recommended.



Solenoid group**	Port size	Function	Orifice (mm)	Operating pressure (bar)	kv value m ³ /h*	kg	Drawing no.	Model
13B	G1/4	NC	1,5	0 ... 40 bar	0,07	0,21	1	9500100xxxx*****
13B	G1/4	NC	2	0 ... 35 bar	0,12	0,21	1	9500200xxxx*****
13C	G1/4	NC	3	0 ... 10 bar	0,20	0,21	1	9500300xxxx*****
13D	G1/4	NC	4	0 ... 12 bar	0,35	0,21	1	9500400xxxx*****
16D	G1/4	NC	6	0 ... 5 bar	0,55	0,25	2	9501600xxxx*****
16D	G1/2	NC	12	0 ... 1 bar	1,70	0,80	4	9501700xxxx*****
13B	G1/4	NO	2	0 ... 20	0,10	0,21	3	9502210xxxx*****
13B	G1/4	NO	3	0 ... 10	0,16	0,21	3	9502310xxxx*****
13B	1/4 NPT	NC	3	0 ... 35 bar	0,12	0,21	1	9503200xxxx*****
13C	1/4 NPT	NC	3	0 ... 10 bar	0,20	0,21	1	9503300xxxx*****
13D	1/4 NPT	NC	4	0 ... 12 bar	0,35	0,21	1	9503400xxxx*****
16D	1/4 NPT	NC	6	0 ... 5 bar	0,55	0,25	2	9504600xxxx*****

xxxx Insert solenoid code from tables below. ***** Insert voltage code from table below

* Cv (US) = kv x 1,2

** For solenoid details, see pages 37 ... 41

Options selector

950XXX★ ★★ ★★ ★★ ★★

Material – seat seal	Substitute
NBR (Perbunan)	0
EPDM	1
FKM (Viton)	2
PTFE (Teflon) (ND 1,5 to 4, NC)	3
FFKM (Kalrez)	4
Rubin (ND 2 & 3, NC)	5

Solenoid
See solenoid tables, pages 37 to 41

Voltage	Substitute
24 V d.c.	02400
24 V a.c.	02450
110 V a.c.	11050
230 V a.c.	23050

Other voltages on request

Accessories

Cable glands	Connectors
Protection class EEx e, EEx d (ATEX), Ms nickel plated brass	



EEx e 0588819 (for solenoid 42xx /46xx M20 x 1,5)	0570275
EEx d 0588851 (for solenoid 46xx M20 x 1,5)	
EEx d, EEx e 0588925 (for solenoid 46xx 1/2-14 NPT)	

Herion 95000 Series

Direct solenoid actuated poppet valves

1,5 to 6 mm orifice (ND)

2/2, NC/NO, G $\frac{1}{4}$, G $\frac{1}{2}$, $\frac{1}{4}$ NPT

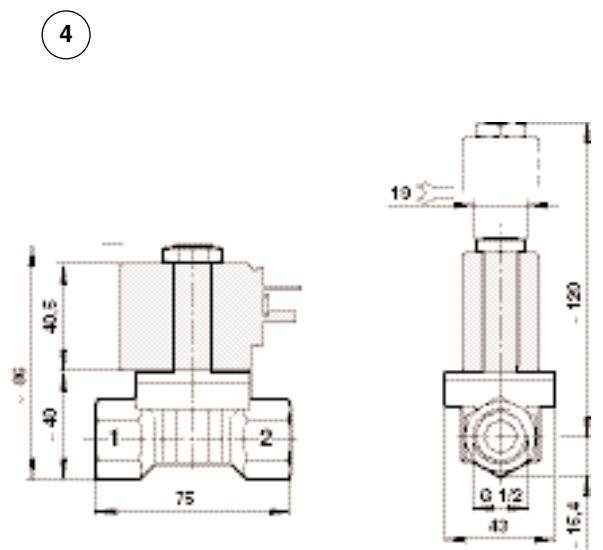
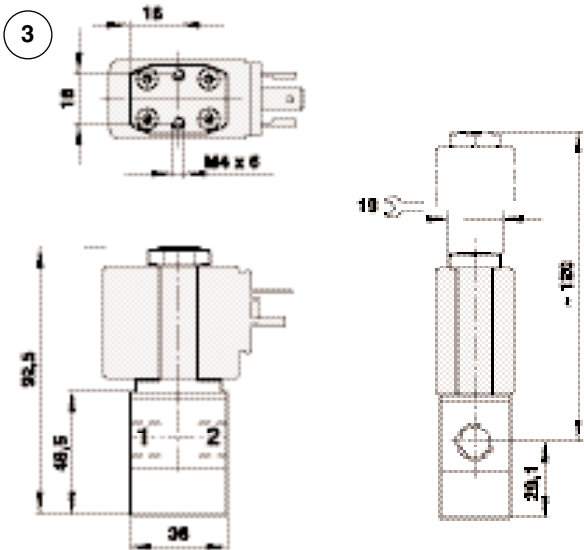
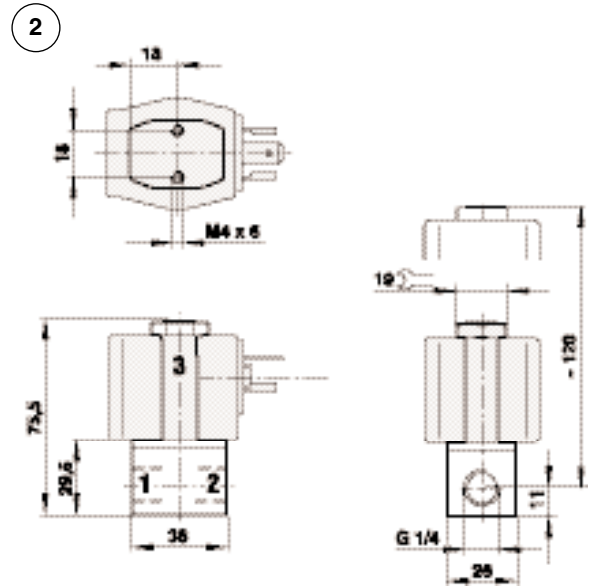
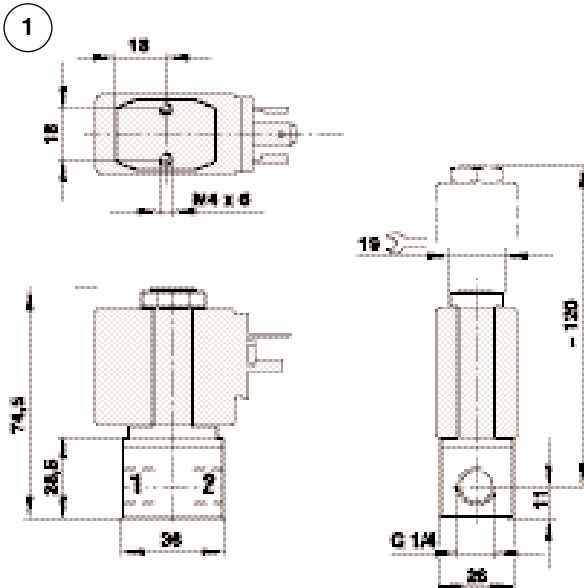

2/2 & 3/2 Solenoid operated valves

Herion 95100 Series

Direct solenoid actuated poppet valves, stainless steel

2 to 6 mm orifice (ND)

2/2, NC, G¹/₈, G¹/₄, 1/4 NPT

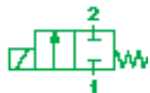

Working from 0 bar up

Suited for fine vacuum down 1.33-10⁻³ mbar-l/s

Assembled free of oil and grease

These solenoids are ATEX and FM, CSA, XP approved

Technical data

Medium:

For aggressive gaseous and liquid fluids*

Operating pressure:

0 to 50 bar

Flow direction:

Fixed

Mounting position:

Optional, preferably with solenoid on top

Fluid temperature:

-10 to +120°C FKM (Viton)

Ambient temperature:

Depending on solenoid system

-10, -25, -40 to +55, +70, +100°C

With minus temperatures, use conditioned dry air. If installed in the open protect all connections against the penetration of moisture

Consult our Technical Service for use below +2°C

Materials

Housing: stainless steel 1.4571/316T

Seat seal: FKM (Viton)

Inner parts: stainless steel

Alternative models

Valves with ultra-low leakage

Fluid temperatures:

-40 to +140°C EPDM

-50 to +180°C PTFE (Teflon)

-10 to +180°C FFKM (Kalrez)

With minus temperatures, use conditioned dry air. If installed in the open protect all connections against the penetration of moisture

For contaminated fluids installation of an upstream filter is recommended.



Solenoid group	Orifice (mm)	Port size	Operating pressure (bar)	kv value m ³ /h*	kg	Drawing no.	Model
13D	2	G1/8	0 ... 50	0,1	0,15	1	9510202xxxx*****
13B	2	G1/8	0 ... 20	0,1	0,15	1	9510202xxxx*****
16D	4	G1/4	0 ... 12	0,34	0,21	2	9511402xxxx*****
16C	4	G1/4	0 ... 5	0,34	0,21	2	9511402xxxx*****
16D	6	G1/4	0 ... 5	0,52	0,21	2	9511602xxxx*****
16C	6	G1/4	0 ... 3	0,52	0,21	2	9511602xxxx*****
16D	4	1/4 NPT	0 ... 12	0,34	0,21	2	9514402xxxx*****
16C	4	1/4 NPT	0 ... 5	0,34	0,21	2	9514402xxxx*****
16D	6	1/4 NPT	0 ... 5	0,52	0,21	2	9514602xxxx*****
16C	6	1/4 NPT	0 ... 3	0,52	0,21	2	9514602xxxx*****

xxxx Insert solenoid code from tables below. ***** Insert voltage code from table below

* Cv (US) ≈ kv x 1,2

Options selector

951XX0★ ★★ ★★ ★★ ★★

Material – seat seal	Substitute	Voltage	Substitute
EPDM	1	24 V d.c.	02400
FKM (Viton)	2	24 V a.c.	02450
PTFE (Teflon), O-ring static FKM (Viton)	3	110 V a.c.	11050
FFKM (Kalrez)	4	230 V a.c.	23050

Other voltages on request

Solenoid: See solenoid tables

Accessories

Cable glands	Connectors
Protection class EEx e, EEx d (ATEX), Ms nickel plated brass	
EEx e 0588819 (for solenoid 42xx /46xx M20 x 1,5)	0570275
EEx d 0588851 (for solenoid 46xx M20 x 1,5)	
EEx d, EEx e 0588925 (for solenoid 46xx 1/2-14 NPT)	

Herion 95100 Series

Direct solenoid actuated poppet valves, stainless steel

2 to 6 mm orifice (ND)

2/2, NC, G $\frac{1}{8}$, G $\frac{1}{4}$, $\frac{1}{4}$ NPT

Solenoid actuators 13B

	Power consumption		Voltage		Protection category	Protection class	Temperatures Ambient/fluid °C	Electrical connection	kg	Solenoid drawing no.#	Circuit diagram no.#	Model
	24 V d.c. (W)	230 V a.c. (VA)	24 V d.c. (mA)	230 V a.c. (mA)								
	8,0	–	331	–	–	IP 65 (with connector) ⁵⁾	-25 ... +60 Fluid: max. 80	DIN EN 175301-803 Form A ⁶⁾	0,15	8	1	0246 ⁷⁾
	–	9,2	–	40	–	IP 65 (with connector) ⁵⁾	-25 ... +60 Fluid: max. 80	DIN EN 175301-803 Form A ⁶⁾	0,16	9	7	3206 ⁷⁾
	8,0	–	331	–	II3G II3D	EEx nA II T4 IP 65 T 110°C	-20 ... +60	DIN EN 175301-803 Form A with special screw	0,16	8	1	3216
	–	9,2	–	40	II3G II3D	EEx nA II T4 IP 65 T 110°C	-20 ... +60	DIN EN 175301-803 Form A with special screw	0,16	9	6	3218
	6,9	–	289	–	II2G II2D	EEx m II T4 IP 66 T 110°C ¹⁾	-20 ... +60	3 m cable	0,40	12	4	0292
	–	8,7	–	34	II2G II2D	EEx m II T4 IP 66 T 110°C ²⁾	-20 ... +60	3 m cable	0,40	12	7	0293
	3,9	–	162	–	II2G II2D	EEx me II T4 IP 66 T 110°C ²⁾	T6: -40 ... +55 T4: -40 ... +80	M20 x 1,5 ⁶⁾	0,50	13	4	4210 ⁸⁾
	–	5,3	–	23	II2G II2D	EEx me II T6/T4 IP 66 T 130°C ²⁾	T6: -40 ... +55 T4: -40 ... +80	M20 x 1,5 ⁶⁾	0,50	13	7	4211 ⁸⁾
	3,9	–	162	–	II2G II2D	EEx md IIC T6/T4 EEx me II T6/T4 IP 66 T 130°C ³⁾	T6: -40 ... +55 T4: -40 ... +80	1/2-14 NPT ⁶⁾	0,80	14	4	4610 ⁸⁾
	–	5,3	–	23	II2G II2D	EEx md IIC T6/T4 EEx me II T6/T4 IP 66 T 130°C ³⁾	T6: -40 ... +55 T4: -40 ... +80	1/2-14 NPT ⁶⁾	0,80	14	7	4611 ⁸⁾
	3,9	–	162	–	II2G II2D	EEx md IIC T6/T4 EEx me II T6/T4 IP 66 T 130°C ³⁾	T6: -40 ... +55 T4: -40 ... +80	M20 x 1,5 ⁶⁾	0,80	14	7	4612 ⁸⁾
	–	5,3	–	23	II2G II2D	EEx md IIC T6/T4 EEx me II T6/T4 IP 66 T 130°C ³⁾	T6: -40 ... +55 T4: -40 ... +80	M20 x 1,5 ⁶⁾	0,80	14	7	4613 ⁸⁾
	5,3	–	23	–	–	Div. 1 and 2 Cl.I, Gr.A-D Cl.II, Gr.E-G Cl.III, T3C (160°C) NEMA 4,4X, 6,6P, 7,9 ⁴⁾	-20 ... +60	Flying leads 450 mm	0,50	15	1	3722
	–	5,3	–	23	–	Div. 1 and 2 Cl.I, Gr.A-D Cl.II, Gr.E-G Cl.III, T3C (160°C) NEMA 4,4X, 6,6P, 7,9 ⁴⁾	-20 ... +60	Flying leads 450 mm	0,50	15	5	3723

Standard voltages 24 V d.c., 230 V a.c. Other voltages on request. Design acc. to VDE 0580, EN 50014/50028. 100% duty cycle.

For solenoid dimensional drawings and circuit diagrams, see page 96

1) Category II 2 GD, EC-Type Examination Certificate KEMA 02 ATEX 1347X

2) Category II 2 GD, EC-Type Examination Certificate KEMA 98 ATEX 4452 X

3) Category II 2 GD, EC-Type Examination Certificate PTB 02 ATEX 2085 X

4) CSA-LR 57643-6, FM approved, for hazardous locations: Div. 1 and 2, Class I, II, III

5) Required connector type 0570275.

6) Connector/cable gland not supplied.

7) Suitable for outdoor installation only if equipped with a special protection (e.g. cubicle installation)

8) This solenoid has a fuse with an appropriate rating.

2/2 & 3/2 Solenoid operated valves







Herion 95100 Series

Direct solenoid actuated poppet valves, stainless steel

2 to 6 mm orifice (ND)

2/2, NC, G $\frac{1}{8}$, G $\frac{1}{4}$, $\frac{1}{4}$ NPT

Solenoid actuators 13C

	Power consumption		Voltage		Protection category	Protection class	Temperatures Ambient/fluid °C	Electrical connection	kg	Solenoid drawing no.#	Circuit diagram no.#	Model
	24 V d.c. (W)	230 V a.c. (VA)	24 V d.c. (mA)	230 V a.c. (mA)								
	12,1	15,0	504	68	–	IP 65 (with connector) ⁵⁾	-25 ... +60 Fluid: max. 80	DIN EN 175301-803 Form A ⁶⁾	0,117	8	1	0200 ⁷⁾
	–	9,2	–	40	–	IP 65 (with connector) ⁵⁾	-25 ... +60 Fluid: max. 80	DIN EN 175301-803 Form A ⁶⁾	0,160	8	5	3206 ⁷⁾
	–	11,3	–	49	–	IP 65 (with connector) ⁵⁾	-25 ... +60 Fluid: max. 80	DIN EN 175301-803 Form A ⁶⁾	0,160	9	6	3204 ⁷⁾
	12,1	–	504	–	II3G II3D	EEx nA II T4 IP 65 T 130°C	T4: -20 ... +60	DIN EN 175301-803 Form A with special screw	0,127	9	1	3217
	–	11,3	–	49	II3G II3D	EEx nA II T4 IP 65 T 120°C	T4: -20 ... +50	DIN EN 175301-803 Form A with special screw	0,170	8	6	3219
	10,7	–	446	–	II2G II2D	EEx m II T4 IP 66 T 110°C ¹⁾	T4: -20 ... +50	3 m cable	0,400	12	4	0290
	–	12,4	–	54	II2G II2D	EEx m II T4 IP 66 T 110°C ¹⁾	T4: -20 ... +50	3 m cable	0,400	12	7	0291
	8,9	–	369	–	II2G ²⁾ II2D	EEx me II T5/T4 IP 66 T 130°C ²⁾	T5: -40 ... +55 T4: -40 ... +65	M20 x 1,5 ⁶⁾	0,500	13	4	4220 ⁸⁾
	–	10,0	–	43	II2G II2D	EEx me II T5/T4 IP 66 T 130°C ²⁾	T5: -40 ... +55 T4: -40 ... +65	M20 x 1,5 ⁶⁾	0,500	13	4	4221 ⁸⁾
	8,9	–	369	–	II2G II2D	EEx md IIC T6/T4 EEx me II T6/T4 IP 66, T 130°C ³⁾	T6: -40 ... +40 T4: -40 ... +70	1/2-14 NPT ⁶⁾	0,800	14	4	4620 ⁸⁾
	–	10,0	–	43	II2G II2D	EEx md IIC T6/T4 EEx me II T6/T4 IP 66, T 130°C ³⁾	T6: -40 ... +40 T4: -40 ... +70	1/2-14 NPT ⁶⁾	0,800	14	7	4621 ⁸⁾
	8,9	–	369	–	II2G II2D	EEx md IIC T6/T4 EEx me II T6/T4 IP 66 T 130°C ³⁾	T6: -40 ... +40 T4: -40 ... +70	M20 x 1,5 ⁶⁾	0,800	14	4	4622 ⁸⁾
	–	10,0	–	43	II2G II2D	EEx md IIC T6/T4 EEx me II T6/T4 IP 66 T 130°C ³⁾	T6: -40 ... +40 T4: -40 ... +70	M20 x 1,5 ⁶⁾	0,800	14	7	4623 ⁸⁾
	8,9	–	369	–	–	Div 1 and 2 Cl.I, Gr. A-D Cl.II, Gr. E-G Cl.III, T3C (160°C) NEMA 4,4X, 6,6P, 7,9 ⁴⁾	-20 ... +60	Flying leads 450 mm	0,500	15	1	3724
	–	9,5	–	41	–	Div 1 and 2 Cl.I, Gr. A-D Cl.II, Gr. E-G Cl.III, T3C (160°C) NEMA 4,4X, 6,6P, 7,9 ⁴⁾	-20 ... +60	Flying leads 450 mm	0,500	15	5	3725

Standard voltages 24 V d.c., 230 V a.c. Other voltages on request. Design acc. to VDE 0580, EN 50014/50028. 100% duty cycle.

For solenoid dimensional drawings and circuit diagrams, see page 96

1) Category II 2 GD, EC-Type Examination Certificate KEMA 02 ATEX 1347X

2) Category II 2 GD, EC-Type Examination Certificate KEMA 98 ATEX 4452 X

3) Category II 2 GD, EC-Type Examination Certificate PTB 02 ATEX 2085 X

4) CSA-LR 57643-6, FM approved, for hazardous locations: Div. 1 and 2, Class I, II, III

5) Required connector type 0570275.

6) Connector/cable gland not supplied.

7) Suitable for outdoor installation only if equipped with a special protection (e.g. cubicle installation)

8) This solenoid has a fuse with an appropriate rating.





Herion 95100 Series

Direct solenoid actuated poppet valves, stainless steel

2 to 6 mm orifice (ND)

2/2, NC, G $\frac{1}{8}$, G $\frac{1}{4}$, 1/4 NPT

Solenoid actuators 13D

	Power consumption		Voltage		Protection category	Protection class	Temperatures Ambient/fluid °C	Electrical connection	kg	Solenoid drawing no.#	Circuit diagram no.#	Model
	24 V d.c. (W)	230 V a.c. (VA)	24 V d.c. (mA)	230 V a.c. (mA)								
	16,9	–	703	–	–	IP 65 (with connector) ⁵⁾	-25 ... +60 Fluid: max. 80	DIN EN 175301-803 Form A ⁶⁾	0,270	10	1	0700 ⁷⁾
	–	17,3	–	75	–	IP 65 (with connector) ⁵⁾	-25 ... +60 Fluid: max. 80	DIN EN 175301-803 Form A ⁶⁾	0,320	11	6	3703 ⁷⁾
	11,4	–	475	–	II2G II2D	EEx me II T5/T4 IP66 T 130°C ²⁾	T5: -40 ... +40 T4: -40 ... +50	M20 x 1,5 ⁶⁾	0,500	13	4	4230 ⁸⁾
	–	15,2	–	66	II2G II2D	EEx me II T5/T4 IP66 T 130°C ²⁾	T5: -40 ... +40 T4: -40 ... +50	M20 x 1,5 ⁶⁾	0,500	13	7	4231 ⁸⁾
	11,4	–	475	–	II2G II2D	EEx md IIC T5/T4 EEx me II T5/T4 IP66 T 130°C ³⁾	T5: -40 ... +40 T4: -40 ... +50	1/2 x 14 NPT ⁶⁾	0,800	14	4	4630 ⁸⁾
	–	15,2	–	66	II2G II2D	EEx md IIC T5/T4 EEx me II T5/T4 IP66 T 130°C ³⁾	T5: -40 ... +40 T4: -40 ... +50	1/2 x 14 NPT ⁶⁾	0,800	14	7	4631 ⁸⁾
	11,4	–	475	–	II2G II2D	EEx md IIC T5/T4 EEx me II T5/T4 IP66 T 130°C ³⁾	T5: -40 ... +40 T4: -40 ... +50	1/2 x 14 NPT ⁶⁾	0,800	14	4	4632 ⁸⁾
	–	15,2	–	66	II2G II2D	EEx md IIC T5/T4 EEx me II T5/T4 IP66 T 130°C ³⁾	T5: -40 ... +40 T4: -40 ... +50	M20 x 1,5 ⁶⁾	0,800	14	7	4633 ⁸⁾
	13,6	–	567	–	–	Div 1 and 2 Cl.I, Gr.A-D Cl.II, Gr. E-G Cl.III T3C (160°C) NEMA 4,4X, 6,6P, 7,9 ⁴⁾	-20 ... +60	Flying leads 450 mm	0,500	15	1	3726
	–	15,7	–	68	–	Div 1 and 2 Cl.I, Gr.A-D Cl.II, Gr. E-G Cl.III T3C (160°C) NEMA 4,4X, 6,6P, 7,9 ⁴⁾	-20 ... +60	Flying leads 450 mm	0,500	15	5	3727

Standard voltages 24 V d.c., 230 V a.c. Other voltages on request. Design acc. to VDE 0580, EN 50014/50028. 100% duty cycle.

For solenoid dimensional drawings and circuit diagrams, see page 96

2) Category II 2 GD, EC-Type Examination Certificate KEMA 98 ATEX 4452 X

3) Category II 2 GD, EC-Type Examination Certificate PTB 02 ATEX 2085 X

4) CSA-LR 57643-6, FM approved, for hazardous locations: Div. 1 and 2, Class I, II,III

5) Required connector type 0570275.

6) Connector/cable gland not supplied.

7) Suitable for outdoor installation only if equipped with a special protection (e.g. cubicle installation)

8) This solenoid has a fuse with an appropriate rating.

2/2 & 3/2 Solenoid operated valves







Herion 95100 Series

Direct solenoid actuated poppet valves, stainless steel

2 to 6 mm orifice (ND)

2/2, NC, G $\frac{1}{8}$, G $\frac{1}{4}$, $\frac{1}{4}$ NPT

Solenoid actuators 16C

	Power consumption		Voltage		Protection category	Protection class	Temperatures Ambient/fluid °C	Electrical connection	kg	Solenoid drawing no.#	Circuit diagram no.#	Model
	24 V d.c. (W)	230 V a.c. (VA)	24 V d.c. (mA)	230 V a.c. (mA)								
	6,8	–	284	–	–	IP 65 (with connector) ⁵⁾	-25 ... +60 Fluid: max. 80	DIN EN 175301-803 Form A ⁶⁾	0,300	10	1	0827 ⁷⁾
	–	10,6	–	46	–	IP 65 (with connector) ⁵⁾	-25 ... +60 Fluid: max. 80	DIN EN 175301-803 Form A ⁶⁾	0,350	11	6	3805 ⁷⁾
	–	10,6	–	46	II3G II3D	EEx nA II T4 IP 65 T 110°C	T4: -20 ... +60	DIN EN 175301-803 Form A, with special screw	–	11	6	3818
		8,9	–	369	–	II2G II2D	EEx me II T5/T4 IP66 T 130°C ²⁾	T5: -40 ... +55 T4: -40 ... +65	M20 x 1,5 ⁶⁾	0,500	13	4
–		10,0	–	43	II2G II2D	EEx me II T5/T4 IP66 T 130°C ²⁾	T5: -40 ... +55 T4: -40 ... +65	M20 x 1,5 ⁶⁾	0,500	13	7	4271 ⁸⁾
	8,9	–	369	–	II2G II2D	EEx md IIC T6/T4 EEx me II T6/T4 IP66 T 130°C ³⁾	T6: -40 ... +40 T4: -40 ... +70	1/2 - 14 NPT ⁶⁾	0,800	14	4	4670 ⁸⁾
	–	10,0	–	43	II2G II2D	EEx md IIC T6/T4 EEx me II T6/T4 IP66 T 130°C ³⁾	T6: -40 ... +40 T4: -40 ... +70	1/2 - 14 NPT ⁶⁾	0,800	14	7	4671 ⁸⁾
	8,9	–	369	–	II2G II2D	EEx md IIC T6/T4 EEx me II T6/T4 IP66 T 130°C ³⁾	T6: -40 ... +40 T4: -40 ... +70	M20 x 1,5 ⁶⁾	0,800	14	4	4672 ⁸⁾
	–	10,0	–	43	II2G II2D	EEx md IIC T6/T4 EEx me II T6/T4 IP66 T 130°C ³⁾	T6: -40 ... +40 T4: -40 ... +70	M20 x 1,5 ⁶⁾	0,800	14	7	4673 ⁸⁾
	8,9	–	369	–	–	Div 1 and 2 Cl.I, Gr.A-D Cl.II, Gr. E-G Cl.III T3C (160°C) NEMA 4,4X, 6,6P, 7,9 ⁴⁾	-20 ... +60	Stranded wire, 3 m long	0,500	15	1	3824
	–	9,5	–	41	–	Div 1 and 2 Cl.I, Gr.A-D Cl.II, Gr. E-G Cl.III T3C (160°C) NEMA 4,4X, 6,6P, 7,9 ⁴⁾	-20 ... +60	Stranded, wire 3 m long	0,500	15	5	3825

Standard voltages 24 V d.c., 230 V a.c. Other voltages on request. Design acc. to VDE 0580, EN 50014/50028. 100% duty cycle.

For solenoid dimensional drawings and circuit diagrams, see page 96

2) Category II 2 GD, EC-Type Examination Certificate KEMA 98 ATEX 4452 X

3) Category II 2 GD, EC-Type Examination Certificate PTB 02 ATEX 2085 X

4) CSA-LR 57643-6, FM approved, for hazardous locations: Div. 1 and 2, Class I, II, III

5) Required connector type 0570275.

6) Connector/cable gland not supplied.

7) Suitable for outdoor installation only if equipped with a special protection (e.g. cubicle installation)

8) This solenoid has a fuse with an appropriate rating.

Herion 95100 Series

Direct solenoid actuated poppet valves, stainless steel

2 to 6 mm orifice (ND)

2/2, NC, G $\frac{1}{8}$, G $\frac{1}{4}$, $\frac{1}{4}$ NPT

Solenoid actuators 16D

	Power consumption		Voltage		Protection category	Protection class	Temperatures Ambient/fluid °C	Electrical connection	kg	Solenoid drawing no.#	Circuit diagram no.#	Model
	24 V d.c. (W)	230 V a.c. (VA)	24 V d.c. (mA)	230 V a.c. (mA)								
	16,9	–	703	–	–	IP 65 (with connector) ⁵⁾	-25 ... +60 Fluid: max. 80	DIN EN 175301-803 Form A ⁶⁾	0,260	10	1	0800 ⁷⁾
	–	17,3	–	75	–	IP 65 (with connector) ⁵⁾	-25 ... +60 Fluid: max. 80	DIN EN 175301-803 Form A ⁶⁾	0,350	11	6	3803 ⁷⁾
	16,9	–	703	–	II3G II3D	EEx nA II T4 IP 65 T 130°C	T4: -20 ... +60	DIN EN 175301-803 Form A, with special screw	0,270	10	1	3817
	–	17,3	–	75	II3G II3D	EEx nA II T4 IP 65 T 120°C	T4: -20 ... +50	DIN EN 175301-803 Form A, with special screw	0,360	11	6	3819
	11,4	–	475	–	II2G II2D	EEx me II T5/T4 IP66 T 130°C ²⁾	T5: -40 ... +40 T4: -40 ... +50	M20 x 1,5 ⁶⁾	0,500	13	4	4280 ⁸⁾
	–	15,2	–	66	II2G II2D	EEx me II T5/T4 IP66 T 130°C ²⁾	T5: -40 ... +40 T4: -40 ... +50	M20 x 1,5 ⁶⁾	0,500	13	7	4281 ⁸⁾
	11,4	–	475	–	II2G II2D	EEx md IIC T5/T4 EEx me II T5/T4 IP66 T 130°C ³⁾	T5: -40 ... +40 T4: -40 ... +50	1/2 x 14 NPT ⁶⁾	0,800	14	4	4680 ⁸⁾
	–	15,2	–	66	II2G II2D	EEx md IIC T5/T4 EEx me II T5/T4 IP66 T 130°C ³⁾	T5: -40 ... +40 T4: -40 ... +50	1/2 x 14 NPT ⁶⁾	0,800	14	7	4681* ⁸⁾
	11,4	–	475	–	II2G II2D	EEx md IIC T5/T4 EEx me II T6/T4 IP66 T 130°C ³⁾	T5: -40 ... +40 T4: -40 ... +50	M20 x 1,5 ⁶⁾	0,800	14	4	4682 ⁸⁾
	–	15,2	–	66	II2G II2D	EEx md IIC T5/T4 EEx me II T6/T4 IP66 T 130°C ³⁾	T5: -40 ... +40 T4: -40 ... +50	M20 x 1,5 ⁶⁾	0,800	14	7	4683 ⁸⁾
	13,6	–	567	–	–	Div 1 and 2 Cl.I, Gr.A-D Cl.II, Gr. E-G Cl.III T3C (160°C) NEMA 4,4X, 6,6P, 7,9 ⁴⁾	-20 ... +60	Flying leads 450 mm	0,500	15	1	3826
	–	15,7	–	68	–	Div 1 and 2 Cl.I, Gr.A-D Cl.II, Gr. E-G Cl.III T3C (160°C) NEMA 4,4X, 6,6P, 7,9 ⁴⁾	-20 ... +60	Flying leads 450 mm	0,500	15	5	3827

Standard voltages 24 V d.c., 230 V a.c. Other voltages on request. Design acc. to VDE 0580, EN 50014/50028. 100% duty cycle.

For solenoid dimensional drawings and circuit diagrams, see page 96

2) Category II 2 GD, EC-Type Examination Certificate KEMA 98 ATEX 4452 X

3) Category II 2 GD, EC-Type Examination Certificate PTB 02 ATEX 2085 X

4) CSA-LR 57643-6, FM approved, for hazardous locations: Div. 1 and 2, Class I, II, III

5) Required connector type 0570275.

6) Connector/cable gland not supplied.

7) Suitable for outdoor installation only if equipped with a special protection (e.g. cubicle installation)

8) This solenoid has a fuse with an appropriate rating.

2/2 & 3/2 Solenoid operated valves

Herion 95100 Series

Direct solenoid actuated poppet valves, stainless steel

2 to 6 mm orifice (ND)

2/2, NC, G $\frac{1}{8}$, G $\frac{1}{4}$, $\frac{1}{4}$ NPT

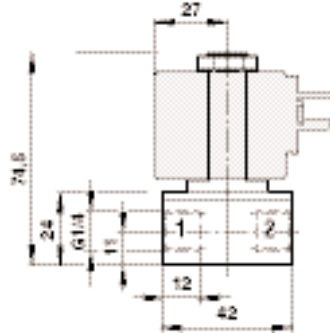
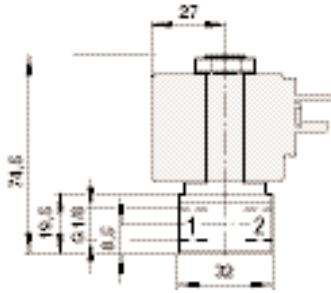
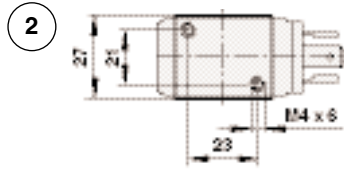
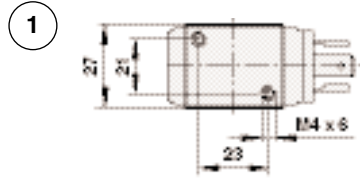

For solenoid dimensions see page 96

Herion 21023 / 21025 Series

Direct solenoid actuated poppet valves

5 and 10 mm orifice (ND)

2/2, NC, G¼, G½

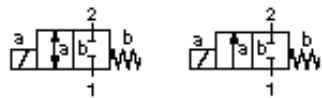

ND 5

ND 10

Working from 0 bar up

Suitable for medium-high vacuum down to 1.33·10⁻² mbar/l/s

Compact design

For a.c. solenoid systems with integrated rectifier (40 to 60 Hz)

These solenoid valves are ATEX approved

Technical data

Medium:

Neutral or aggressive gases and liquids

Flow direction:

Any (5 mm orifice)

Defined (10 mm orifice)

Mounting position:

Any, but preferably with solenoid vertical

Fluid temperature:

-25 to +80°C (NBR)

-10 to +120°C (FPM = Viton), water up

to +95°C

-50 to +180°C (PTFE)

Ambient temperature:

+80°C max. (dependent on solenoid)

Consult our Technical Service for use below +2°C

Switching cycles:

100/min

Materials

Valve housing: brass, stainless steel 1.4571/316T

Seals: NBR (Perbunan), FPM (Viton), PTFE (Teflon), EPDM, FFPM/Hi-Fluor

Internal parts: brass, stainless steel

1.4104/430F, high-purity ferritic chrome steel

Alternative models

For low and high ambient and fluid temperatures

With manual override

Free of oil and grease for oxygen

For contaminated fluids installation of an upstream filter is recommended.



Orifice (mm)	Port size	Operating pressure (bar)	kv value m ³ /h*	Materials Housing	Seat seal	kg (without solenoid)	Drawing no.	Model
5	G 1/4	0 ... 10	0,46	Brass	NBR	0,75	1	2102300xxxx*****
5	G 1/4	0 ... 10	0,46	Brass	FPM	0,75	1	2102308xxxx*****
5	G 1/4	0 ... 10	0,46	S/steel 1.4571/316T	FPM	0,8	1	2102304xxxx*****
5	G 1/4	0 ... 10	0,46	S/steel 1.4571/316T	PTFE	0,8	1	2102307xxxx*****#
10	G 1/2	0 ... 10	1	Brass	NBR	0,95	2	2102500xxxx*****
10	G 1/2	0 ... 10	1	Brass	FPM	0,95	2	2102503xxxx*****
10	G 1/2	0 ... 10	0,75	S/steel 1.4571/316T	PTFE	1	2	2102524xxxx*****#
10	G 1/2	0 ... 10	0,75	S/steel 1.4571/316T	FPM	1	2	2102525xxxx*****‡

xxxx Insert solenoid code from tables below. ***** Insert voltage code from table below

* Cv (US) ≈ kv x 1,2

'O'-ring FPM (Viton)

‡ Slot ring PTFE (Teflon)

Options selector

2102XXX *****

Solenoid	Voltage	Substitute
See solenoid tables	24 V d.c.	02400
	24 V a.c.	02450
	110 V a.c.	11050
	230 V a.c.	23050

Other voltages on request

Accessories

Cable glands

Protection class EEx e, EEx d (ATEX), Ms nickel plated brass

Connectors



EEx e 0588819 (for solenoid 42xx /46xx M20 x 1,5)

0570275

EEx d 0588851 (for solenoid 46xx M20 x 1,5)

EEx d, EEx e 0588925 (for solenoid 46xx 1/2-14 NPT)





Herion 21023 / 21025 Series

Direct solenoid actuated poppet valves

5 and 10 mm orifice (ND)

2/2, NC, G $\frac{1}{4}$, G $\frac{1}{2}$

Solenoid actuators

	Power consumption		Voltage		Protection category	Protection class	Temperatures Ambient/fluid °C	Electrical connection	kg	Solenoid drawing no.#	Circuit diagram no.#	Model
	24 V d.c. (W)	230 V a.c. (VA)	24 V d.c. (mA)	230 V a.c. (mA)								
	16,9	–	703	–	–	IP00 without plug ⁵⁾ IP65 with plug ⁵⁾	-25 ... +60	DIN EN175W301-803 Form A ⁶⁾	0,33	10	1	0800 ⁷⁾
	–	18	–	75	–	IP00 without plug ⁵⁾ IP65 with plug ⁵⁾	-25 ... +60	DIN EN175W301-803 Form A ⁶⁾	0,34	11	6	3803 ⁸⁾
	8,9	–	369	–	II2G	EEx me II T4/T5 ²⁾ IP66 T130°C	-40 ... +65/55	M20x1,5 ⁶⁾	0,6	13	4	4270 ⁸⁾
	–	10	–	43	II2D	EEx me II T4/T5 ²⁾ IP66 T130°C	-40 ... +65/55	M20x1,5 ⁶⁾	0,6	13	7	4271 ⁸⁾
	8,9	–	369	–	II2G	EEx md IIC T4/T6 ³⁾ EEx me IIC TT4/T6 ³⁾ IP66 T130°C	-40 ... +65/55	1/2 NPT ⁶⁾	0,8	14	4	4670 ⁸⁾
	–	10	–	43	II2D	EEx md IIC T4/T6 ³⁾ EEx me IIC TT4/T6 ³⁾ IP66 T130°C	-40 ... +65/55	1/2 NPT ⁶⁾	0,8	14	7	4671 ⁸⁾
	8,9	–	369	–	II2G	EEx md IIC T4/T6 ³⁾ EEx me IIC TT4/T6 ³⁾ IP66 T130°C	-40 ... +65/55	M20x1,5 ⁶⁾	0,8	14	4	4672 ⁸⁾
	–	10	–	43	II2D	EEx md IIC T4/T6 ³⁾ EEx me IIC T6 ³⁾ IP66 T130°C	-40 ... +65/55	M20x1,5 ⁶⁾	0,8	14	7	4673 ⁸⁾
	13,6	–	566	–	–	XP NEMA ⁴⁾	-20 ... +60	4 x Flying leads	0,4	15	1	3826
	–	15,7	–	68	–	4, 4X, 6, 6P, 7, 9 XP NEMA ⁴⁾	-20 ... +60	4 x Flying leads	0,4	15	5	3827

Standard voltages 24 V d.c., 230 V a.c. Other voltages on request. Design acc. to VDE 0580, EN 50014/50028. 100% duty cycle.

For solenoid dimensional drawings and circuit diagrams, see page 96

2) Category II 2 GD, EC-Type Examination Certificate KEMA 98 ATEX 4452 X

6) Connector/cable gland not supplied, see 'Accessories' table

3) Category II 2 GD, EC-Type Examination Certificate PTB 02 ATEX 2085 X

7) Suitable for outdoor installation only if equipped with a special protection (e.g. cubicle installation)

4) CSA-LR 57643-6, FM approved, for hazardous locations: Div. 1 and 2, Class I, II, III

8) This solenoid has a fuse with an appropriate rating.

5) Required connector type 0570275.

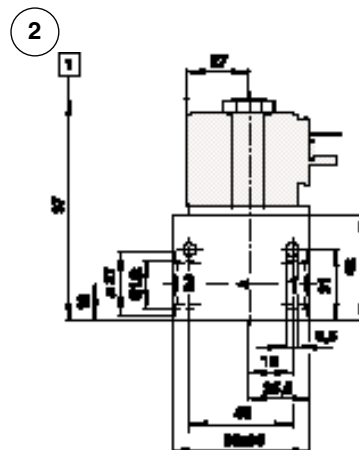
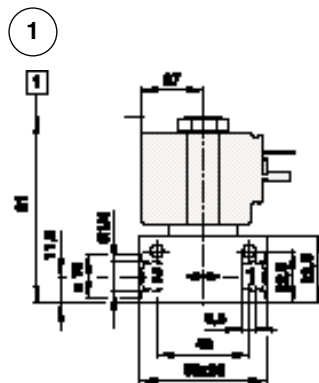

1 Clearance distance ~120 mm

Herion 21000 Series

Direct acting solenoid valves

8 & 12 mm orifice (ND)

2/2, NC, G¼ to G½

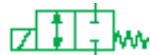

Working from 0 bar up

Suitable for fluid-high vacuum range down to 1.33·10⁻² mbar-l/s

Valve seals in either direction

Technical data

Medium:

For neutral gaseous and liquid fluids

Operating pressure:

0 to 50 bar

Flow direction:

Optional

Mounting position:

Optional, preferably vertical

Fluid temperature:

-25* to +80°C NBR (Perbunan)

*With minus temperatures, use conditioned dry air. If installed in the open protect all connections against the penetration of moisture

Ambient temperature:

Depending on solenoid system

-25 to +60, +80°C

Consult our Technical Service for use below +2°C

Materials

Housing: brass

Seat seal: NBR (Perbunan)

Inner part: brass, steel 1.4104/430F

Alternative models

Seat seal FPM (Viton), PTFE (Teflon), EPDM

With manual override

With inductive or electromechanical limit switches

For contaminated fluids installation of an upstream filter is recommended.



Solenoid group	Orifice (mm)	Port size	Operating pressure (bar)	kv value m³/h*	kg (without solenoid)	Drawing no.	Model
30,5A	8	G 1/4	0 ... 15	0,87	2,1	1	1520450xxxx*****
30,5A	8	G 3/8	0 ... 15	0,87	2,1	1	1520550xxxx*****
30,5A	8	G 1/2	0 ... 15	0,87	2,1	1	1520650xxxx*****
30,5A	12	G 3/8	0 ... 15	1,0	2,5	2	2102150xxxx*****
30,5A	12	G 1/2	0 ... 15	1,0	2,5	2	2102250xxxx*****
38,5A	12	G 3/8	0 ... 50	1,0	3,6	3	2101750xxxx*****
38,5A	12	G 1/2	0 ... 50	1,0	3,6	3	2101850xxxx*****
30,5A	12	G 1/2	0 ... 15	1,0	2,5	3	2112250xxxx*****
38,5A	12	G 1/2	0 ... 50	1,0	3,6	3	2111850xxxx*****

xxxx Insert solenoid code from tables below. ***** Insert voltage code from table below

* Cv (US) ≈ kv x 1,2

Options selector

152/21X XXXX ★★★★★

Solenoid	Voltage	Substitute
See solenoid tables	24 V d.c.	02400
	24 V a.c.	02450
	110 V a.c.	11050
	230 V a.c.	23050

Other voltages on request

Accessories

Port size	Cable glands Protection class IP65 Ms nickel plated brass	Cable glands Protection class EEx e, EEx d (ATEX), Ms nickel plated brass
-----------	---	---



M20 x 1,5*	0589241 (Ø 6,5...9,5 mm)	EEx e 0588819
M20 x 1,5	0589242 (Ø 9,0...13 mm)	EEx d 0588851
1/2 NPT		EEx d, EEx e 0588925

* Included in delivery for IP65

Herion 21000 Series

Direct acting solenoid valves

8 & 12 mm orifice (ND)

2/2, NC, G $\frac{1}{4}$ to G $\frac{1}{2}$

Solenoid actuators 30,5A

	Power consumption		Voltage		Ex- Protection category	Protection class	Temperatures Ambient/fluid °C	Electrical connection	kg	Solenoid drawing no.#	Circuit diagram no.#	Model
	24 V d.c. (W)	230 V a.c. (VA)	24 V d.c. (mA)	230 V a.c. (mA)								
	21,4	–	891	–	–	IP65 with cable gland	-25 ... +60	M20x1,5	1,35	1	2	1300
	–	22,8	–	99	–	IP65 with cable gland	-25 ... +60	M20x1,5	1,35	1	6	1301
	21,4	–	891	–	II2G	EEx me II T4 ¹⁾ EEx me II T5 ¹⁾	-20 ... +80 -40 ... +60	M20x1,5 ⁴⁾	2,0	2	4	1440
	–	22,8	–	99	II2G	EEx me II T4 ¹⁾ EEx me II T5 ¹⁾	-40 ... +80 -40 ... +60	M20x1,5 ⁴⁾	2,0	2	7	1441

Solenoid actuators 38,5A

	Power consumption		Voltage		Ex- Protection category	Protection class	Temperatures Ambient/fluid °C	Electrical connection	kg	Solenoid drawing no.#	Circuit diagram no.#	Model
	24 V d.c. (W)	230 V a.c. (VA)	24 V d.c. (mA)	230 V a.c. (mA)								
	35,9	–	1497	–	–	IP65 with cable gland	-25 ... +60 Fluid max. +80	M20x1,5	2,5	4	2	1500
	–	38,9	–	169	–	IP65 with cable gland	-25 ... +60 Fluid max. +80	M20x1,5	2,5	4	6	1501
	35,9	–	1497	–	II2G	EEx me IIC T5 ²⁾	-20 ... +40	M20x1,5 ⁴⁾	3,6	5	2	1570
	–	38,9	–	169	II2G	EEx me II T5 ²⁾	-20 ... +40	M20x1,5 ⁴⁾	3,6	5	6	1571

Standard voltages 24 V d.c., 230 V a.c. Other voltages on request. Design acc. to VDE 0580, EN 50014/50028. 100% duty cycle.

For solenoid dimensional drawings and circuit diagrams, see page 51

1) EC-Type-Examination-Certificate KEMA 03 ATEX 1016 X

2) EC-Type-Examination-Certificate PTB 03 ATEX 2032 X

3) Cable gland not supplied, see 'Accessories' table

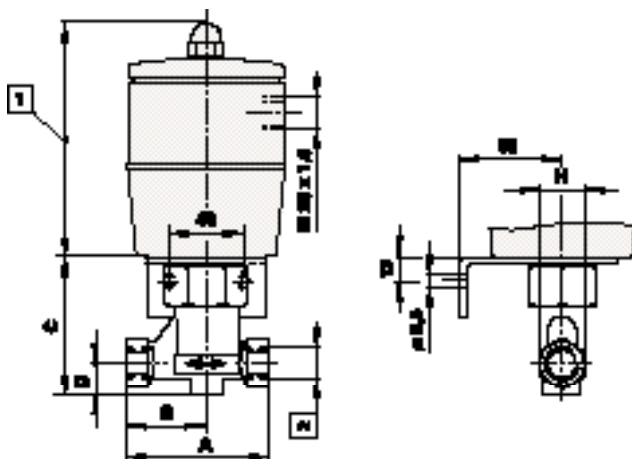

1 For solenoid dimensions see page 51

2 For port size, see previous page

Drawing no.	A	C	D	G	H
1	80	77	21	44	30
2	90	82	22	51	38
3	90	87	22	51	38

Herion 23200 Series

Direct acting solenoid valves

12 to 40 mm orifice (ND)

2/2, NC/NO, G½ to G2

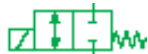

Working from 0 bar up

Suitable for vacuum down to 1.33 mbar-l/s

Seals in either flow direction

Suitable for shut-off systems

High corrosion resistance (stainless steel)

Technical data

Medium:

Neutral gases and liquids, aggressive (1.4581/316Ti) gases and liquids

Operating pressure:

25 bar max.

Flow direction:

Optional

Mounting position:

Optional, preferably vertical

Fluid temperature:

-25* to +80°C (brass)

-10* to +80°C (grey cast iron)

-10* to +120°C (stainless steel)

*With minus temperatures, use conditioned dry air.

Ambient temperature:

Depending on solenoid system

-25 to +80°C (brass)

-10 to +80°C (grey cast iron, 1.4581/316Ti)

Consult our Technical Service for use below +2°C

Electrical connection:

M20 x 1,5 and 1/2 NPT

Materials

Housing: brass, grey cast iron, stainless steel (1.4581/316Ti)

Seat seal: NBR (Perbunan), FPM (Viton)

Inner part: brass, stainless steel

Alternative models

Inner part material 1.4571/316T

Seat seal material FPM (Viton), EPDM

Manual override with and without detent
Inductive and electromechanical limit switches

For contaminated fluids installation of an upstream filter is recommended.



Solenoid group	Orifice (mm)	Port size	Function	Operating pressure (bar)	kv value m³/h*	Materials Housing	Seat seal	kg	Drawing no.	Model
30,5A	12	G 1/2	NC	0 ... 15	1,4	Brass	NBR	3,0	1	2323120xxxx*****
38,5A	12	G 1/2	NC	0 ... 25	1,2	Brass	NBR	4,3	2	2324120xxxx*****
38,5A	20	G 3/4	NC	0 ... 10	6,5	Grey cast iron	NBR	5,5	3	2323420xxxx*****
47,5A	20	G 3/4	NC	0 ... 25	6,5	Grey cast iron	NBR	7,5	4	2324420xxxx*****
38,5A	25	G 1	NC	0 ... 6	9,0	Grey cast iron	NBR	6,0	3	2322520xxxx*****
47,5A	25	G 1	NC	0 ... 10	9,0	Grey cast iron	NBR	8,0	4	2323620xxxx*****
47,5A	25	G 1	NC	0 ... 25	9,0	Grey cast iron	NBR	8,0	4	2324620xxxx*****
47,5B	40	G 1½	NC	0 ... 10	16,5	Grey cast iron	NBR	9,5	5	2323820xxxx*****
47,5B	40	G 2	NC	0 ... 10	16,5	Grey cast iron	NBR	9,5	5	2323920xxxx*****
30,5A	12	G 1/2	NO	0 ... 15	1,4	Brass	NBR	3,0	1	2326120xxxx*****
38,5A	12	G 1/2	NO	0 ... 25	1,2	Brass	NBR	4,3	2	2327120xxxx*****
38,5A	20	G 3/4	NO	0 ... 10	6,5	Grey cast iron	NBR	5,5	3	2326420xxxx*****
47,5A	20	G 3/4	NO	0 ... 25	6,5	Grey cast iron	NBR	7,5	4	2327420xxxx*****
38,5A	25	G 1	NO	0 ... 6	9,0	Grey cast iron	NBR	6,0	3	2325520xxxx*****
47,5A	25	G 1	NO	0 ... 10	9,0	Grey cast iron	NBR	8,0	4	2326620xxxx*****
47,5A	25	G 1	NO	0 ... 25	9,0	Grey cast iron	NBR	8,0	4	2327620xxxx*****
47,5B	40	G 1½	NO	0 ... 10	16,5	Grey cast iron	NBR	9,5	5	2326820xxxx*****
47,5B	40	G 2	NO	0 ... 10	16,5	Grey cast iron	NBR	9,5	5	2326920xxxx*****

For aggressive fluids

Solenoid group	Orifice (mm)	Port size	Function	Operating pressure (bar)	kv value m³/h*	Materials Housing	Seat seal	kg	Drawing no.	Model
38,5A	15	G 1/2	NC	0 ... 10	6,0	S/steel 1.4581/316Ti	FKM	6,0	3	2324157xxxx*****
38,5A	25	G 1	NC	0 ... 10	6,5	S/steel 1.4581/316Ti	FKM	6,0	3	2322557xxxx*****

xxxx Insert solenoid code from tables below. ***** Insert voltage code from table below

* Cv (US) ≈ kv x 1,2

Options selector

232XXXX ★★★★★

Solenoid	Voltage	Substitute
See solenoid tables	24 V d.c.	02400
	24 V a.c.	02450
	110 V a.c.	11050
	230 V a.c.	23050

Other voltages on request

Accessories

Port size	Cable glands Protection class IP65 Ms nickel plated brass	Cable glands Protection class EEx e, EEx d (ATEX), Ms nickel plated brass
M20 x 1,5*	0589241 (Ø 6,5 ... 9,5 mm)	EEx e 0588819
M20 x 1,5	0589242 (Ø 9,0 ... 13 mm)	EEx d 0588851
1/2 NPT		EEx d, EEx e 0588925

* Included in delivery for IP65



Herion 23200 Series

Direct acting solenoid valves

12 to 40 mm orifice (ND)

2/2, NC/NO, G½ to G2



Solenoid actuators 30,5A

	Power consumption		Voltage		Protection category	Protection class	Temperatures Ambient/fluid °C	Electrical connection	kg	Solenoid drawing no.#	Circuit diagram no.#	Model
	24 V d.c. (W)	230 V a.c. (VA)	24 V d.c. (mA)	230 V a.c. (mA)								
	21,4	–	891	–	–	IP65 with cable gland	-25 ... +60	M20x1,5	1,35	1	2	1300
	–	22,8	–	99	–	IP65 with cable gland	-25 ... +60	M20x1,5	1,35	1	6	1301
	21,4	–	891	–	II2G	EEx me II T4 ¹⁾ EEx me II T5 ¹⁾	-20 ... +80 -40 ... +60	M20x1,5 ³⁾	2,0	2	4	1440
	–	22,8	–	99	II2G	EEx me II T4 ¹⁾ EEx me II T5 ¹⁾	-40 ... +80 -40 ... +60	M20x1,5 ³⁾	2,0	2	7	1441

Solenoid actuators 30,5B

	Power consumption		Voltage		Protection category	Protection class	Temperatures Ambient/fluid °C	Electrical connection	kg	Solenoid drawing no.#	Circuit diagram no.#	Model
	24 V d.c. (W)	230 V a.c. (VA)	24 V d.c. (mA)	230 V a.c. (mA)								
	21,4	–	891	–	II2G	EEx EEX d IIC T4 ²⁾	-40 ... +60	1/2 NPT ⁴⁾	3,3	3	2	1480
	–	22,8	–	99	II2D	IP66 T90°C	-40 ... +60	1/2 NPT ⁴⁾	3,3	3	6	1481

Solenoid actuators 38,5A

	Power consumption		Voltage		Protection category	Protection class	Temperatures Ambient/fluid °C	Electrical connection	kg	Solenoid drawing no.#	Circuit diagram no.#	Model
	24 V d.c. (W)	230 V a.c. (VA)	24 V d.c. (mA)	230 V a.c. (mA)								
	35,9	–	1497	–	–	IP65 with cable gland	-25 ... +60 Fluid max. +80	M20x1,5	2,5	4	2	1500
	–	38,9	–	169	–	IP65 with cable gland	-25 ... +60 Fluid max. +80	M20x1,5	2,5	4	6	1501
	35,9	–	1497	–	II2G	EEx me IIC T5 ²⁾	-20 ... +40	M20x1,5 ⁴⁾	3,6	5	2	1570
	–	38,9	–	169	II2G	EEx me II T5 ²⁾	-20 ... +40	M20x1,5 ⁴⁾	3,6	5	6	1571

Solenoid actuators 38,5B

	Power consumption		Voltage		Protection category	Protection class	Temperatures Ambient/fluid °C	Electrical connection	kg	Solenoid drawing no.#	Circuit diagram no.#	Model
	24 V d.c. (W)	230 V a.c. (VA)	24 V d.c. (mA)	230 V a.c. (mA)								
	35,9	–	1497	–	II2G	EEx d IIC T4 ²⁾	-40 ... +60	1/2 NPT ⁴⁾	4,2	3	2	1680
	–	38,9	–	169	II2D	IP66 T105°C	-40 ... +60	1/2 NPT ⁴⁾	4,2	3	6	1681

Solenoid actuators 47,5A

	Power consumption		Voltage		Protection category	Protection class	Temperatures Ambient/fluid °C	Electrical connection	kg	Solenoid drawing no.#	Circuit diagram no.#	Model
	24 V d.c. (W)	230 V a.c. (VA)	24 V d.c. (mA)	230 V a.c. (mA)								
	52,5	–	2181	–	–	IP65 with connector ⁴⁾	-40 ... +40° Fluid 80° max.	M20x1,5	4,6	6	2	1600
	–	56,4	–	245	–	IP65 with connector ⁴⁾	-40 ... +40° Fluid 80° max.	M20x1,5	4,6	6	6	1601

Solenoid actuators 47,5B

	Power consumption		Voltage		Protection category	Protection class	Temperatures Ambient/fluid °C	Electrical connection	kg	Solenoid drawing no.#	Circuit diagram no.#	Model
	24 V d.c. (W)	230 V a.c. (VA)	24 V d.c. (mA)	230 V a.c. (mA)								
	62,5	–	2606	–	–	IP65 with connector ⁴⁾	-40...+40° Fluid 80° max.	M20x1,5	9,7	7	2	1700
	–	58,9	–	256	–	IP65 with connector ⁴⁾	-40...+40° Fluid 80° max.	M20x1,5	9,7	7	6	1701

Standard voltages 24 V d.c., 230 V a.c. Other voltages on request. Design acc. to VDE 0580, EN 50014/50028. 100% duty cycle.

1) EC-Type-Examination-Certificate KEMA 03 ATEX 1016 X

2) EC-Type-Examination-Certificate EXAM PTB 03 ATEX 2032 X

3) EC-Type-Examination-Certificate PTP ATEX 2032 X

4) Cable gland not supplied, see 'Accessories' table

For solenoid dimensional drawings and circuit diagrams, see page 51

Herion 23200 Series

Direct acting solenoid valves

12 to 40 mm orifice (ND)

2/2, NC/NO, G½ to G2

1 2

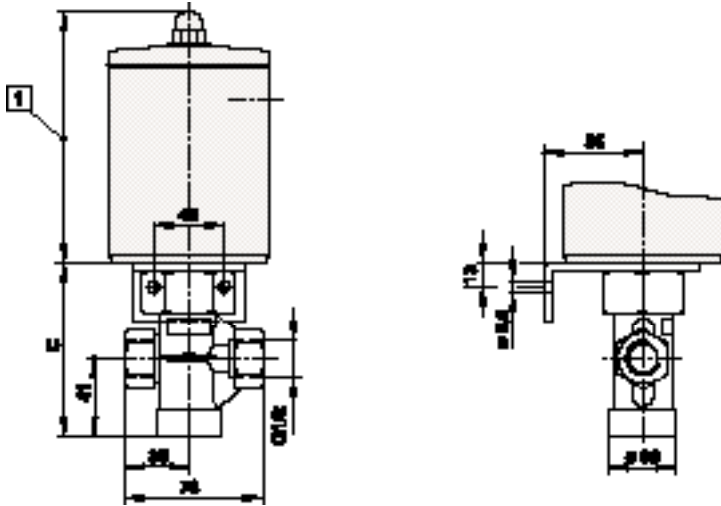

Drawing no.	C
1	90
2	96

3 4 5

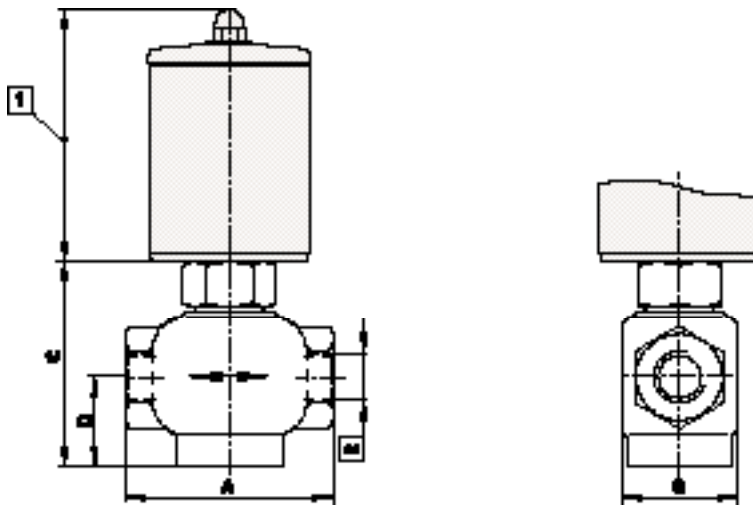

Drawing no.	A	C	D	G
3	118	120	50,5	66
4	118	125	50,5	66
5	180	179	79	94

1 For solenoid dimensions see page 51

2 For port size, see page 48

Solenoid dimensional drawings

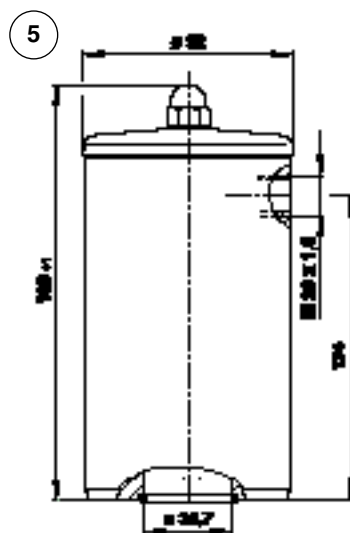
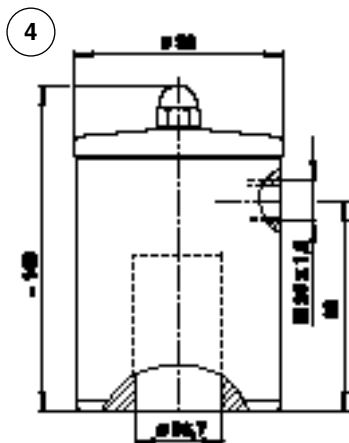
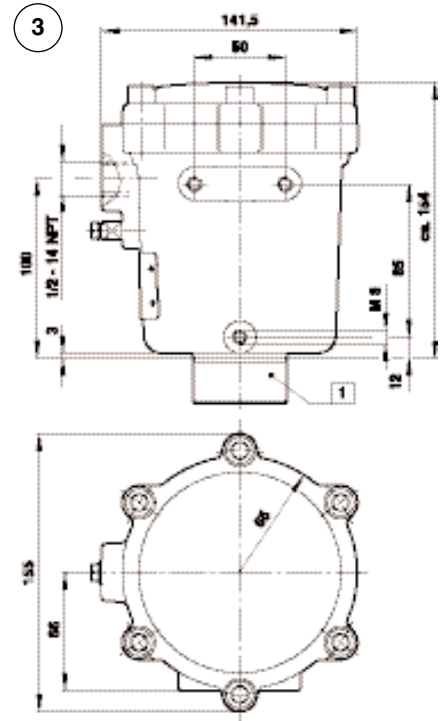
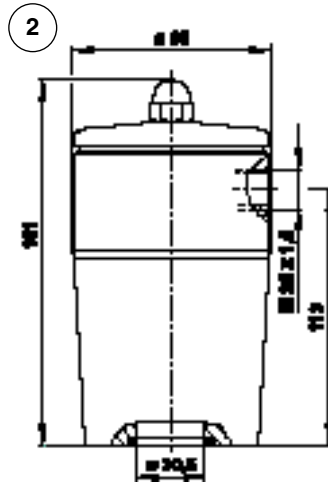
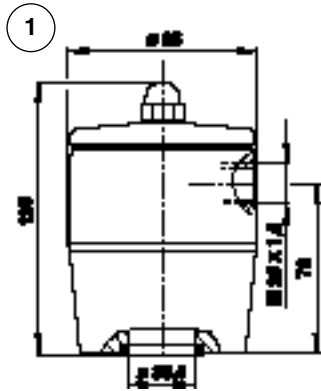

Circuit diagrams

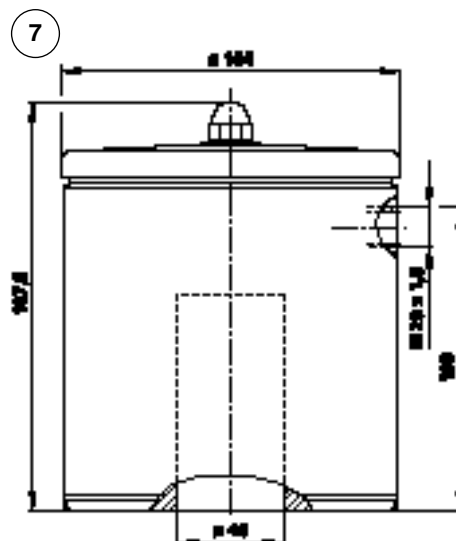
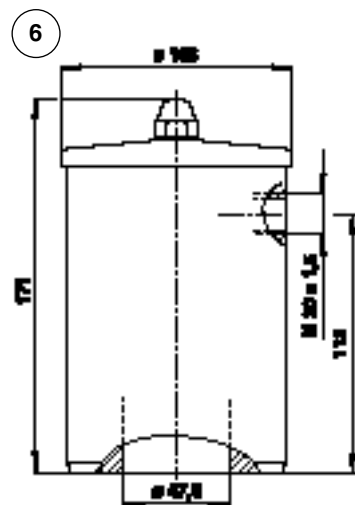
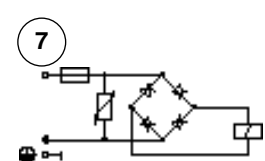
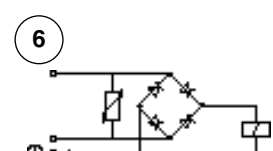
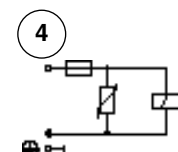
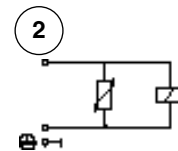

Webber cartridge solenoid valves

Direct acting solenoid valves
1,0 mm to 2,0 mm orifice (ND)
 2/2, 3/2, NC

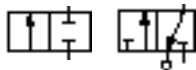

Compact, fully encapsulated assembly
2/2 or 3/2 function with collected exhaust
Screw mounting
Maximum environmental protection
Maximum protection from vibration and impact damage
Flying leads



Technical data

Medium:
 Compressed air, lubricated and non lubricated, filtered to 50 µm

Operating pressure:
 0 to 10 bar

Flow:

Inlet orifice	Kv m ³ /h	NFPA Cv	l/min
1,0 mm	0,027	0,031	31
1,6 mm	0,069	0,08	80
2,0 mm	0,108	0,125	125

Mounting:
 Screw mounting

Ambient temperature:
 -40°C to +50°C (+80°C for automotive specifications)

Supply temperature:
 -40°C to +90°C
 Consult our Technical Service for use below +2°C

Life expectancy:
 20 to 100 million cycles

Vibration immunity:
 200 hours salt spray; UL94 V0; Vibration to EN60068-2-6

Weight: 0,08 kg

Materials

Coil: glass reinforced PET
 Armature: stainless iron
 Stem tube: stainless steel
 Springs: stainless steel
 Seals: nitrile or viton

Standard models

Function	Orifice (mm)	Operating pressure (bar)	Power (W)	Model
2/2 NC	1,00	10	3,4	VSD2CAD4-K19*K
2/2 NC	1,00	10	6	VSD2CAD4-K13*K
2/2 NC	1,60	10	6	VSD2CAG4-K13*K
2/2 NC	2,00	10	6	VSD2CAH4-K13*K
3/2 NC	1,00	10	3,4	VSD7CAD4-K19*K
3/2 NC	1,00	10	6	VSD7CAD4-K13*K
3/2 NC	1,60	7	6	VSD7CAG4-K13*K
3/2 NC	2,00	7	6	VSD7CAH4-K13*K

Automotive models

Function	Orifice (mm)	Operating pressure (bar)	Power (W)	Model
2/2 NC	1,00	10	4,7	VSD2CAD4-K1V*K
3/2 NC	1,00	10	4,7	VSD7CAD4-K1V*K

* Insert voltage code from table below.

Voltage codes

Supply d.c.	Power (W)	Code
12 V	2	2
	3,4	2
	4,7	2
	6	2
24 V	2	3
	3,4	3
	4,7	3
	6	3

Electrical information

Voltages:	12 V & 24 V d.c.
Voltage tolerance:	±10% Standard specification ±25% Automotive specification
Power:	3,4 & 6 W Standard specification 4,7 W Automotive specification
Typical electrical response time:	On 10 to 20 ms
Protection class:	IP65 (DIN 40 050) with cable clamp
Electrical duty:	100% E.D.
Coil:	Screwed to customer interface
Electrical connections:	Flying lead

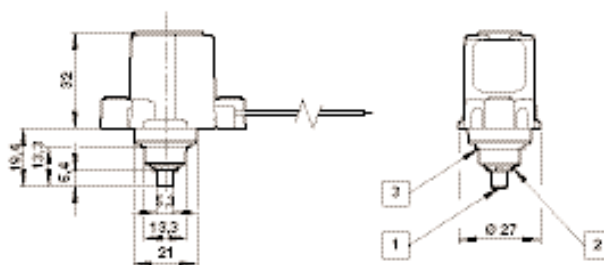

	2/2 NC	3/2 NC
Port 1	Delivery	Inlet
Port 2	Inlet	Delivery
Port 3	Not Used	Exhaust



Webber Excel 22 Dual control

Twin 22 mm direct acting solenoid valves
4 mm, 6 mm push-in

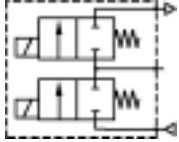

Twin solenoid offers dual control
Two 2/2 normally closed valves combined in a single unit
Integral push in fittings for simple and rapid installation
Ideal for applications requiring inflation and deflation control

Technical data

Medium:
Compressed air, filtered, lubricated and non-lubricated

Operating pressure:
Up to 10 bar

Flow:
29 l/min

Ambient temperature:
-20°C to +50°C
Consult our Technical Service for use below +2°C

Weight: 200 g

Materials

Base: Hostaform plastic resin
 Coil: glass reinforced thermoplastic
 Armature: stainless iron
 Stem tube: stainless steel
 Springs: stainless steel
 Seals: nitrile rubber

Alternative models

Flying lead coils

Function	Orifice (mm)	Operating pressure (bar)	Power (W/VA)	Model
2/2 NC	1,0	10	2 W	VSD2DAD1-A1***

***Insert voltage code from table below.

Electrical details for solenoid operators

Voltage tolerance:	±10%
Power consumption:	2 W
Electrical duty:	100 % E.D.
Electrical connections:	3 flat pin (Industrial standard)
Manual override:	None
Protection class:	IP 65 (DIN 40 050) with connector plug fitted

For details of connector plugs and indicators please contact our Technical Service

Voltage codes

Supply d.c.	Code
12 V d.c.	12J
24 V d.c. 50/60 Hz	13J

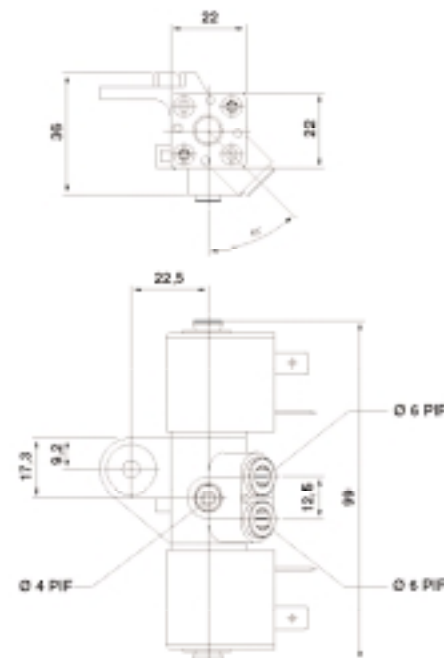

Webber ink jet valve

Direct acting solenoid valves

Manifold mounted

1,5 mm orifice (ND)

2/2, 3/2

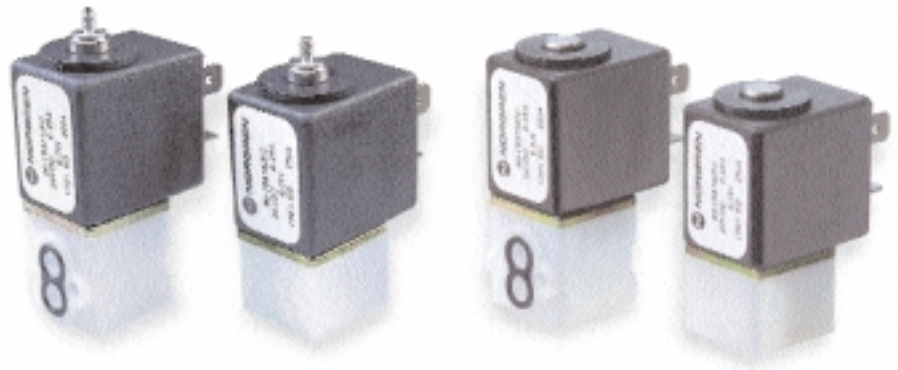
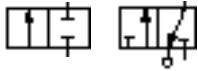

Compact, 22 mm solenoid valves

Vertical or horizontal mounting options

Compatible with multiple inks and flushing medias

Proven reliability

Technical data

Medium:

Methyl ethyl ketone

Ethyl acetate

Water/glycol

Ethanol

Methanol

Acetone (40° maximum)

Operation:

Poppet valve, direct actuated with spring return.

Operating pressure:

-0,5 to 4,5 bar (max.)

Flow:

≤ 100 c.c./min at 0,5 bar differential

Ambient temperature:

+50°C

Supply temperature:

+55°C

Consult our Technical Service for use below +2°C

Life expectancy:

Typically in excess of 10 million cycles

Weight: 0,09 kg (without plug)

Materials

Valve base: Delrin

Coil: glass reinforced thermoplastic moulded

Stem tube: stainless steel

Armature: stainless steel

Springs: stainless steel wire

Seals: EPDM

Alternative models

2 wire electrical flying leads

Table B Din 43650 electrical connections

Alternative materials

Manifolds

Description	Orifice (mm)	Operating pressure (bar)	Power (W)	Model
3/2 NC & 3/2 Change over – side ported	1,5	-0,5 ... 4,5	6	90-19371/PC
3/2 NC & 3/2 Change over – interface base	1,5	-0,5 ... 4,5	6	90-19375/PC
2/2 Change over – side ported	1,5	-0,5 ... 4,5	6	90-19372/PC
2/2 Change over – interface base	1,5	-0,5 ... 4,5	6	90-19376/PC

Electrical information

Voltage:	24 V d.c. ± 10%
d.c. Power:	6 W
Typical electrical response time:	On 10 to 20 ms Off 5 to 10 ms
Protection class:	IP 65 (DIN 40 050) with connector plug fitted
Electrical duty:	100% (Continuously rated)
Coil:	22 mm removable encapsulated; 3 pin

Webber ink jet valve

Direct acting solenoid valves

Manifold mounted

1,5 mm orifice (ND)

2/2, 3/2

90-19376/PC
2/2 N/C

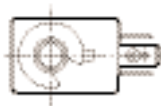
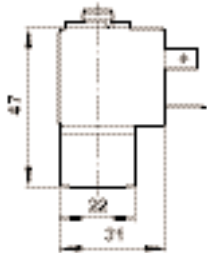
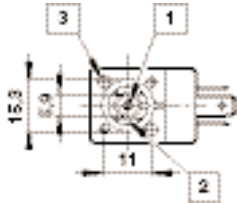

- 1 Port 1
- 2 Port 2 area
- 3 2 x Ø 3,3 mm mounting holes to suit countersunk head screws

90-19372/PC
2/2 N/C

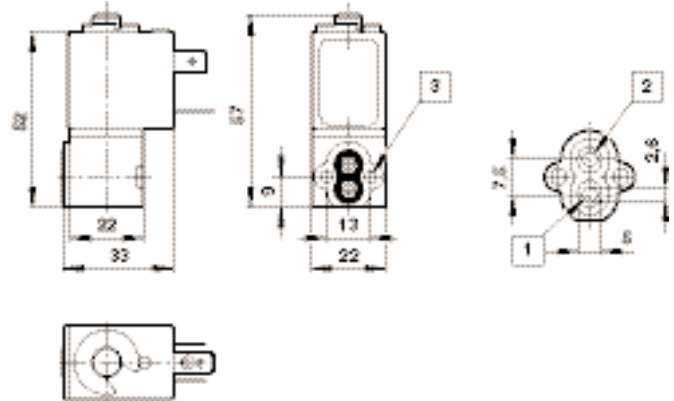

- 1 Port 1
- 2 Port 2
- 3 2 x Ø 3,5 mm mounting holes to suit pan head screws

90-19375/PC
3/2 NC & 3/2 Changeover

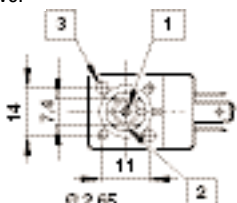

2 x Ø 3,3 mm mounting holes to suit countersunk head screws

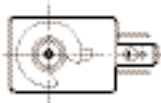

- 1 Port 1
- 2 Port 2 area
- 3 2 x Ø 3,3 mm mounting holes to suit countersunk head screws
- 4 Port 3

90-19371/PC
3/2 NC & 3/2 Changeover

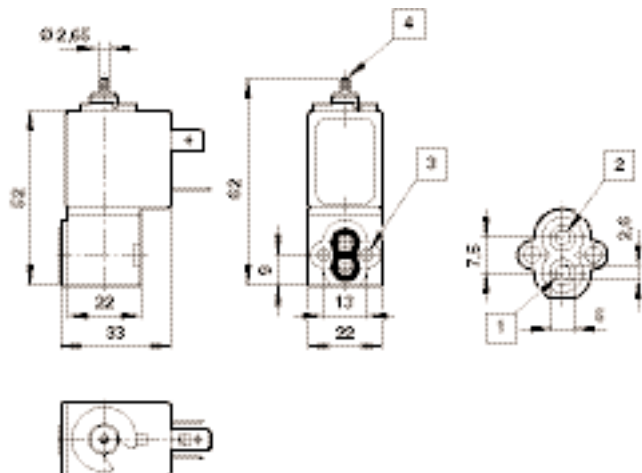

- 1 Port 1
- 2 Port 2
- 3 2 x Ø 3,5 mm mounting holes to suit pan head screws
- 4 Port 3

Webber base ported mini valves

Direct acting solenoid valves

Manifold mounted

1,8 mm orifice (ND)

3/2, NC/NO, G $\frac{1}{4}$ inlet & exhaust, G $\frac{3}{8}$ outlet



22 mm miniature base ported solenoid valves

Normally closed and normally open on the same manifold

Collected exhaust

Interchangeable coils

Technical data

Medium:

Compressed air, filtered, lubricated and non-lubricated

Light oil, water and other non-corrosive liquids and gases

Operating pressure:

0 to 5 bar (max.)

Flow:

Inlet orifice	Kv	m ³ /h	NFPA Cv	l/min
1,8 mm	0,079	0,091	90	

Mounting:

M4 threaded holes in manifold on centres

Ambient temperature:

-20°C to +50°C

Supply temperature:

-20°C to +70°C

Consult our Technical Service for use below +2°C

Life expectancy:

Typically in excess of 10 million cycles

Weight: N x 0,19 kg (N = number of stations)

Materials

Valve base: moulded PBT

Coil: glass reinforced thermoplastic

Manifold: anodised aluminium

Armature: stainless iron

Stem tube: stainless steel

Springs: stainless steel

Seals: nitrile rubber

Alternative models

Vacuum operation

2 wire electrical flying leads

Table B DIN 43650 Electrical connectors

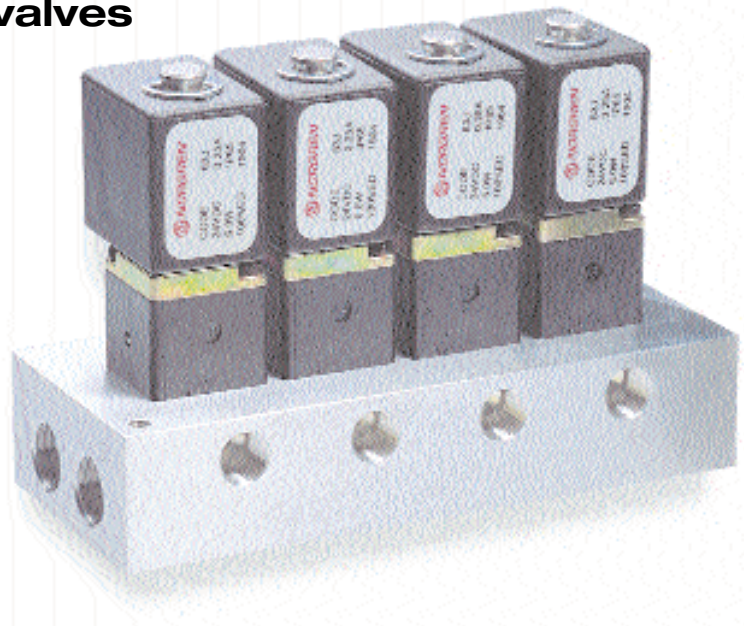

Function	Orifice (mm)	Operating pressure (bar)	Power (W)	Manual override	Model
3/2 NC	1,8	5	6 or 7,5	None	VSD7P5U1-A1800 *
3/2 NO	1,8	5	6 or 7,5	None	VSD6P5U1-A1800 *

*Please order plugs separately using the model numbers from the Voltage code tables below

Voltage codes

Voltage	Code	Power (W)	Model Supply d.c.
12 V d.c.	82J	7,5	QM/48/82J/21
24 V d.c.	83J	6	QM/48/83J/21
110 V d.c.	89J	7,5	QM/48/87J/21

Voltage	Code	Power (VA)	Model Supply a.c.
24 V a.c. 50/60 Hz	84J	12/8	90-19517/CW
115 V a.c. 50/60 Hz	88J	12/8	90-19517/CG
230 V a.c. 50/60 Hz	89J	12/8	90-19517/PB

* a.c. coils are supplied with a rectified plug and must be used with this plug

Electrical information

Voltage tolerance	±10% as standard
d.c. Power	7,5 W (6 W for 24 V d.c. high power coils)
Typical electrical response time	On 10 to 20 ms Off 5 to 10 ms
Protection class	IP 65 (DIN 40 050) with connector plug fitted
Electrical duty	100% (Continuously rated)
Coil	22 mm removable encapsulated
Electrical connections	3 flat pin (Industrial standard)
Connector plug	Plug available

Manifolds

No. of stations	Port size	Porting	Model
1	G1/8	Base ported	81088001
2	G1/8	Base ported	81088002
3	G1/8	Base ported	81088003
4	G1/8	Base ported	81088004
5	G1/8	Base ported	81088005
6	G1/8	Base ported	81088006
7	G1/8	Base ported	81088007
8	G1/8	Base ported	81088008

Webber base ported mini valves

Direct acting solenoid valves

Manifold mounted

1,8 mm orifice (ND)

3/2, NC/NO, G $\frac{1}{4}$ inlet & exhaust, G $\frac{1}{8}$ outlet

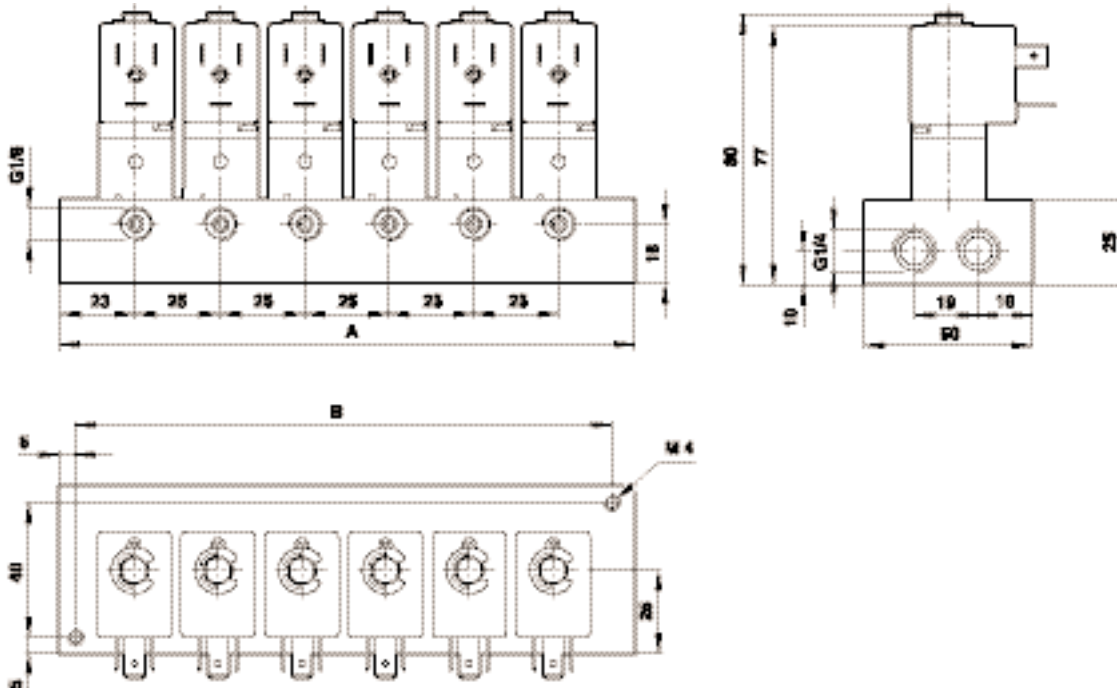

Manifolds

Manifold	A	B
Single station	45	35
Multiple stations	$25 \times (N-1) + 45$	$25 \times (N-1) + 35$

N = number of stations

Webber water management valve

Direct acting solenoid valves

In-line

1,2 mm to 2,0 mm orifice (ND)

2/2, 15 mm compression fittings



Compact, 22 mm miniature solenoid valves

In line 15 mm compression fittings

Latching version for zero power consumption

Suitable for use with standard water industry fittings

Technical data

Medium:

Potable and non-potable water and non-corrosive liquids and gases

Connections:

Integral 15 mm compression fittings

Operating pressure:

0 to 10 bar (max.)

Flow:

Inlet orifice l/min*

1,2 mm 2

1,6 mm 3,5

2,0 mm 4,5

* l/min calculation tested at 6 bar in, 5 bar out

Mounting:

In line, freestanding position

Ambient temperature:

-20°C to +50°C

Supply temperature:

-20°C to +90°C

Consult our Technical Service for use below +2°C

Life expectancy:

Typically in excess of 20 million cycles

Weight: 0,22 kg (without plug)

Materials

Base, compression fittings and olives: brass

Valve base: moulded plastic (fortron)

Inlet filter: stainless steel

Coil: glass reinforced epoxy compound

Alternative models

Viton (FPM) seal material

2 wire electrical flying leads

Table B DIN 43650 electrical connections

30 mm low power coils with Table A DIN 43650 electrical connections

Vacuum operation

Non standard a.c. and d.c. voltages up to + 30% tolerance

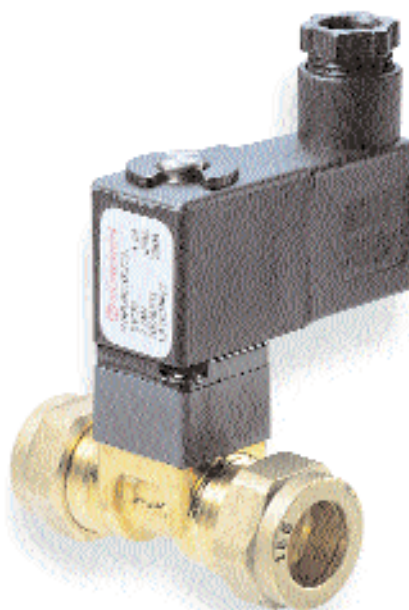

2/2 Normally closed

Orifice (mm)	Operating pressure (bar)	Power (W/VA)	Manual override	Model
1,2	10	6 or 7,5/8	None	WMS50000/**
1,6	10	6 or 7,5/8	None	WMS60000/**
2	7	6 or 7,5/8	None	WMS10000/**
1,2	10	6 or 7,5/8	Screwdriver	WMS51000/**
1,6	10	6 or 7,5/8	Screwdriver	WMS61000/**
2	7	6 or 7,5/8	Screwdriver	WMS11000/**

** Insert voltage code from table below

Voltage codes

Supply d.c.	Power (W)	Code
12 V	7,5	CB
24 V	6	PC
24 V 50/60 Hz	8	BB
110 V 50/60 Hz	8	BF
240 V 50/60 Hz	8	BJ

a.c. valves have a characteristic hum. If quiet operation is required a rectified option is available. Please contact our Technical Service for details

2/2 Normally closed, latching

Orifice (mm)	Operating pressure (bar)	Micro-amp hours	Manual override	Model
1,2	10	17	None	WML50000/**
1,6	10	17	None	WML60000/**
2	7	17	None	WML10000/**

** Insert voltage code from table below

Voltage codes

Supply d.c.	Code
6 V	CA
9 V	PG
12 V	CB

a.c. valves have a characteristic hum. If quiet operation is required a rectified option is available. Please contact our Technical Service for details

Electrical information

Voltage tolerance	+ 10% as standard
d.c. Power	7,5 W (6 W for 24 V d.c. coils)
a.c. Power inrush/hold	8/12 VA
Latching valve power consumption	Zero - 50 ms pulse required to operate the valve (7,5 W d.c. coil)
Typical electrical response time	On 10 to 20 ms Off 5 to 10 ms
Protection class	IP 65 (DIN 40 050) with connector plug fitted
Electrical duty	100 % (Continuously rated)
Coil	22 mm removable encapsulated
Electrical connections	3 flat pin (Industrial standard)
Connector plug	Supplied without plug.
Manual override	Screwdriver - memory type (Turn 180° anti-clockwise to operate, turn clockwise to release)

Webber water management valve

Direct acting solenoid valves

In-line

1,2 mm to 2,0 mm orifice (ND)

2/2, 15 mm compression fittings

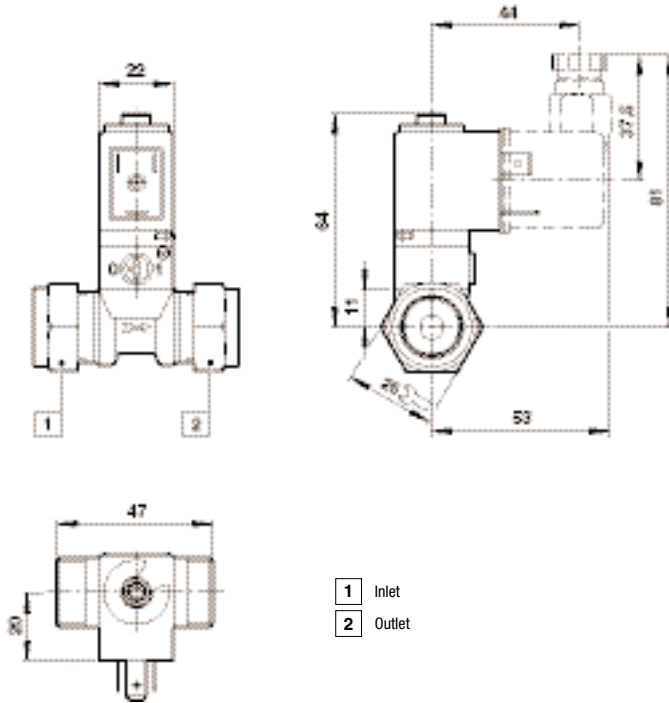

2/2 & 3/2 Solenoid operated valves

Webber Excel 22 (M/48, M/49)

22 mm Direct acting solenoid valves

Sub-base mounted

1,0 & 1,6 mm orifice (ND)

3/2, NC, M5, G $\frac{1}{8}$

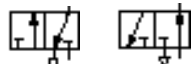

Miniature 22 mm normally open and normally closed models

Sub-base mounted and manifold mounted - compact and convenient

Manual override as standard

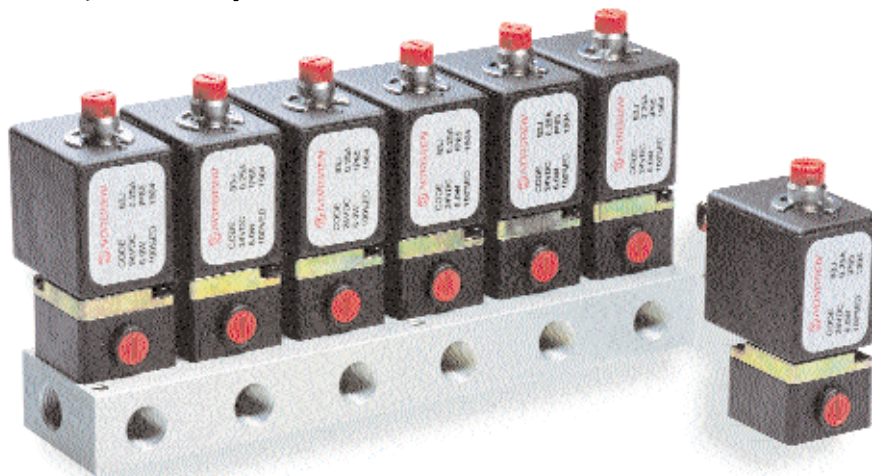

Technical data

Medium:

Compressed air, filtered, lubricated and non lubricated.

Operating pressure:

0 to 10 bar

Flow:

Orifice l/min

1,0 mm 30

1,6 mm 77

Ambient temperature:

-20°C to +50°C.

Consult our Technical Service for use below +2°C

Materials

Coil: glass reinforced thermo plastic

Manual override base: glass reinforced nylon

Armature: stainless iron

Sub-base: aluminium

Seals: nitrile

Tube & spring: stainless steel

Alternative models

2/2 N/C models

N/O models

Push button manual operators

15 mm models

32 mm models

Flying lead coils

Viton

Contact our Technical Service for details.

Size	Function	Actuation	kg	Mounting	Model 1,0 mm orifice (low power)	1,6 mm orifice
M5	3/2 NC	Sol/spring	0,13	Single	M/48/MAZ***	M/48/MDZ***
M5	3/2 NC	Sol/spring	0,31 ... 0,9	Manifold	DM/48/MAZ***/T#	DM/48/MDZ***/T#
G1/8	3/2 NC	Sol/spring	0,14	Single	M/49/MAZ***	M/49/MDZ***
G1/8	3/2 NC	Sol/spring	0,31 ... 0,9	Manifold	DM/49/MAZ***/T#	DM/49/MDZ***/T#

Service kits are not available for these valves.

*** Insert voltage codes from table below.

No. of stations up to 6 maximum.

Order connector plugs separately.

Electrical details for solenoid operators

Voltage tolerance:	±10%
Rating:	100% E.D.
Inlet orifice:	1,0 mm or 1,6 mm
Electrical connection:	22 mm Industrial Standard*
Protection class:	IP 65 (DIN 40 050) with plug fitted
Cable entry:	Pg 9
Manual override:	Screwdriver operated, memory type, standard

*Form B electrical connections available - please refer to data sheets.

Voltage codes

Voltage	1,0 mm orifice (low power)			1,6 mm orifice		
	Code	Power	Coil	Code	Power	Coil
12 V d.c.	12J	2 W	QM/48/12J/21	82J	7,5 W	QM/48/82J/21
24 V d.c.	13J	2 W	QM/48/13J/21	83J	6 W	QM/48/83J/21
24 V 50/60 Hz	14J	4/2,5 VA	QM/48/14J/21	84J	12/8 VA	QM/48/84J/21
110/120 V 50/60 Hz	18J	4/2,5 VA	QM/48/18J/21	88J	12/8 VA	QM/48/88J/21
220/240 V 50/60 Hz	19J	6/5 VA	QM/48/19J/21	89J	12/8 VA	QM/48/89J/21

a.c. valves have a characteristic hum. If quiet operation is required please refer to table below for our rectified coil and plug option.

Rectified plug option

Supply a.c.	1,0 mm orifice (low power)			1,6 mm orifice		
	Power (VA)	Code	Coil	Power (VA)	Code	Coil
24 V 50/60 Hz	4/2,5	14J	90-19517/VE	12/8	84J	90-19517/CW
115 V 50/60 Hz	4/2,5	18J	90-19517/CG	12/8	88J	90-19517/CG
230 V 50/60 Hz				12/8	89J	90-19517/PB

For details of connector plugs and indicators please contact our Technical Service

These coils are supplied complete with a rectified plug and must be used only with this plug.

Webber Excel 22 (M/48, M/49)

22 mm Direct acting solenoid valves

Sub-base mounted

1,0 & 1,6 mm orifice (ND)

3/2, NC, M5, G1/8

M/48, M/49

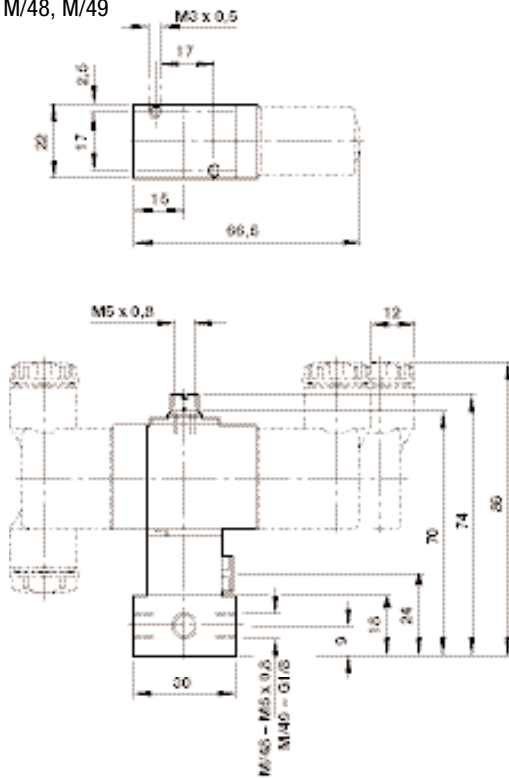

DM/48/*T#, DM/49/*T#

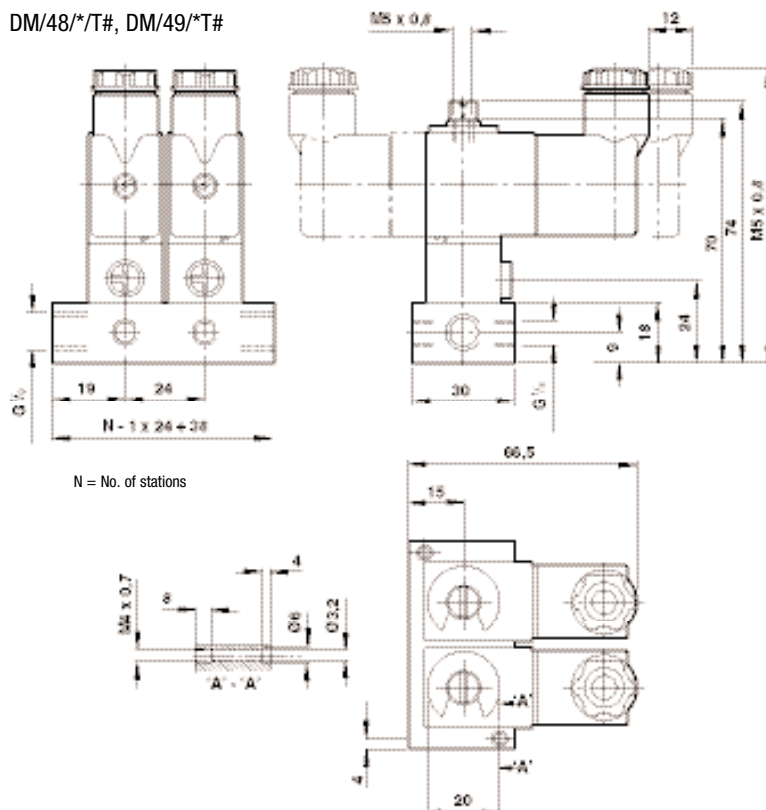

N = No. of stations

2/2 & 3/2 Solenoid operated valves

Webber Excel 22 1/8" BSP

22 mm Direct acting solenoid valves

In-line

1,0 mm to 3,0 mm orifice (ND)

2/2, 3/2, NC/NO, G1/8



Compact, 22 mm miniature solenoid valves

In line G 1/8 ported brass base

Normally closed and normally open models

Low power option

Memory-type manual override

Diffuser supplied with 3/2 normally closed models

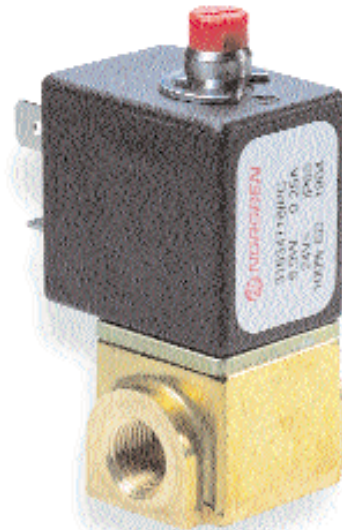

Technical data

Medium:

Compressed air, filtered, lubricated and non-lubricated. Light oil, water and other non-corrosive liquids and gases

Operating pressure:

0 to 12 bar

Flow:

Inlet orifice	Kv m ³ /h	NFPA Cv	l/min
1,0 mm	0,026	0,029	29
1,6 mm	0,068	0,078	77
2,0 mm	0,100	0,115	113
3,0 mm	0,134	0,154	152

Mounting:

2 M3 x 5 deep fixing holes in base

Ambient temperature:

-20°C to +50°C

Supply temperature:

-20°C to +90°C

Consult our Technical Service for use below +2°C

Life expectancy:

Typically in excess of 20 million cycles

Weight: 0,16 kg (without plug)

Materials

Base: brass

Coil: glass reinforced epoxy compound

Armature: stainless iron

Stem tube: stainless steel

Springs: stainless steel

Seals: nitrile rubber (Viton top seat)

Alternative models

Viton (FPM) seal material

Replacement coils

2 wire electrical flying leads

Table B DIN 43650 electrical connections

30 mm low power coils with Table A DIN 43650 electrical connections

Vacuum operation

Zero power latching (impulse) valves

Non standard a.c. and d.c. voltages up to + 30% tolerance

Connector plugs – order separately

Function	Orifice (mm)	Operating pressure (bar)	Power consumption (W)	Manual override	Model
2/2 NC	1,0	12	6 or 7,5 / 8	None	33604110/**
2/2 NC	1,6	11	6 or 7,5 / 8	None	33604116/**
2/2 NC	2,0	10	6 or 7,5 / 8	None	33604120/**
2/2 NC	3,0	5	6 or 7,5 / 8	None	33604130/**
2/2 NC	1,0	12	6 or 7,5 / 8	Screwdriver	33904110/**
2/2 NC	1,6	11	6 or 7,5 / 8	Screwdriver	33904116/**
2/2 NC	2,0	10	6 or 7,5 / 8	Screwdriver	33904120/**
2/2 NC	1,0	10	3,4 / 2,5 or 5	None	35604110/**
2/2 NC	1,6	4	3,4 / 2,5 or 5	None	35604116/**
2/2 NC	2,0	3	3,4 / 2,5 or 5	None	35604120/**
2/2 NC	3,0	1	3,4 / 2,5 or 5	None	35604130/**
2/2 NC	1,0	10	3,4 / 2,5 or 5	Screwdriver	35904110/**
2/2 NC	1,6	4	3,4 / 2,5 or 5	Screwdriver	35904116/**
2/2 NC	2,0	3	3,4 / 2,5 or 5	Screwdriver	35904120/**
2/2 NC	1,0	10	2 / 2,5 or 5	None	35604188/**
2/2 NC	1,0	10	2 / 2,5 or 5	Screwdriver	35904188/**
3/2 NC	1,0	12	6 or 7,5 / 8	None	31604110/**
3/2 NC	1,6	10	6 or 7,5 / 8	None	31604716/**
3/2 NC	2,0	7	6 or 7,5 / 8	None	31604720/**
3/2 NC	3,0	3	6 or 7,5 / 8	None	31604730/**
3/2 NC	1,0	12	6 or 7,5 / 8	Screwdriver	31904110/**
3/2 NC	1,6	10	6 or 7,5 / 8	Screwdriver	31904716/**
3/2 NC	2,0	7	6 or 7,5 / 8	Screwdriver	31904720/**
3/2 NC	1,0	10	3,4 / 2,5 or 5	None	34604110/**
3/2 NC	1,6	3	3,4 / 2,5 or 5	None	34604716/**
3/2 NC	2,0	3	3,4 / 2,5 or 5	None	34604720/**
3/2 NC	3,0	1	3,4 / 2,5 or 5	None	34604730/**
3/2 NC	1,0	10	3,4 / 2,5 or 5	Screwdriver	34904110/**
3/2 NC	1,6	3	3,4 / 2,5 or 5	Screwdriver	34904716/**
3/2 NC	2,0	3	3,4 / 2,5 or 5	Screwdriver	34904720/**
3/2 NC	1,0	10	2 / 2,5 or 5	None	34604188/**
3/2 NC	1,0	10	2 / 2,5 or 5	Screwdriver	34904188/**
3/2 NO	1,6	10	6 or 7,5 / 8	None	31605516/**
3/2 NO	1,6	10	6 or 7,5 / 8	Screwdriver	31905516/**
3/2 NO	1,0	10	3,4 / 2,5 or 5	None	34605010/**
3/2 NO	1,0	10	3,4 / 2,5 or 5	Screwdriver	34905010/**

** Insert voltage code from tables below

Voltage codes

Supply DC	Power consumption (W)	Code
12 V	7,5	CB
	3,4	BB
	2	EB
24 V	6	PC
	3,4	BE
	2	EC

Other voltages on request.

a.c. voltages are available. Please consult our Technical Service for details.

Webber Excel 22 1/8" BSP

22 mm Direct acting solenoid valves

In-line

1,0 mm to 3,0 mm orifice (ND)

2/2, 3/2, NC/NO, G1/8

Electrical information

Voltage tolerance	±10% as standard
d.c. Power	2, 3,4, 7,5 W (6 W for 24 V d.c. high power coils)
Typical electrical response time	On 10 to 20 ms Off 5 to 10 ms
Protection class	IP 65 (DIN 40 050) with connector plug fitted
Electrical duty	100% (Continuously rated)
Coil	22 mm removable encapsulated
Electrical connections	3 flat pin (Industrial standard)
Connector plug	Supplied without plug. Order separately.
Manual override	Screwdriver - memory type Turn 180° anti-clockwise to operate, turn clockwise to release

2/2

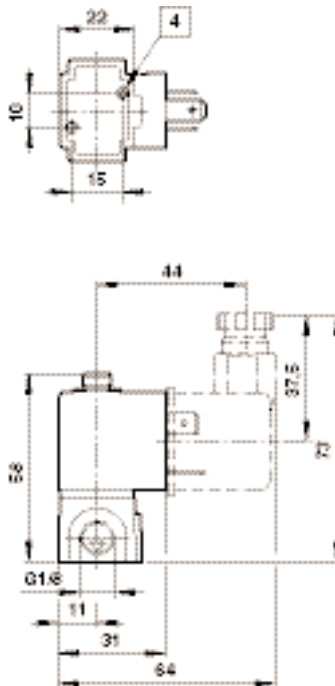

3/2

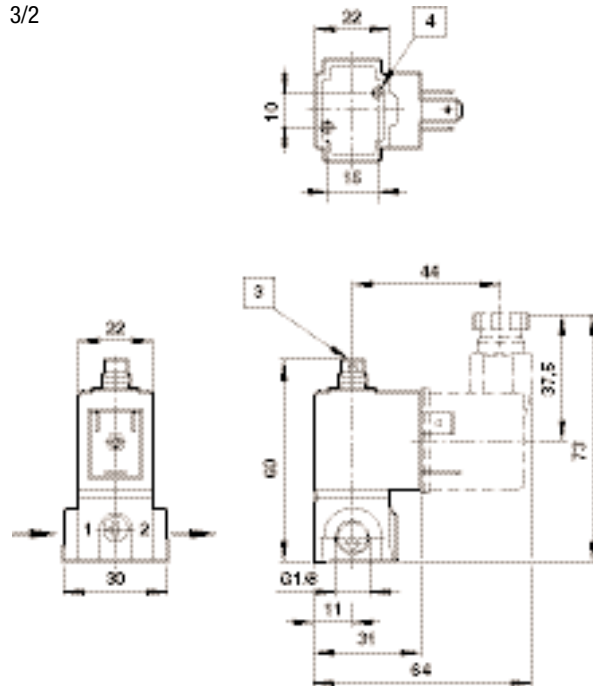

- 3 Port 3
- 4 M3 x 5 deep fixing holes

Port	2/2 NC	3/2 NC
1	Outlet	Inlet
2	Inlet	Outlet
3	Exhaust	

2/2 & 3/2 Solenoid operated valves

Webber Excel 22 Hosetail

22 mm Direct acting solenoid valve

In-line

2,0 mm orifice (ND)

2/2, 3/2, NC, 6 mm hosetail

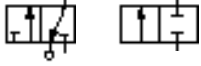

Compact, 22 mm miniature solenoid valves

In-line hosetail connections to suit 6 mm I/D flexibe tubing

Low power option

Removable and interchangeable coils

Diffuser supplied

Technical data

Medium:

Compressed air, filtered, lubricated and non-lubricated. Light oil, water and other non-corrosive liquids and gases

Operating pressure:

3/2 NC: 0 to 6 bar (max)

2/2 NC: 0 to 10 bar (max)

Flow:

Inlet orifice	Kv m ³ /h	NFPA Cv	l/min
2,0 mm	0,100	0,115	113,0

Mounting:

Two 2,48 x 8 deep holes in base to suit no. 4 self-tapping screws

Ambient temperature:

-20°C to +50°C

Supply temperature:

-20°C to +90°C

Consult our Technical Service for use below +2°C

Life expectancy:

Typically in excess of 20 million cycles

Weight: 0,09 kg (without plug)

Materials

Base: polyester

Coil: glass reinforced epoxy compound

Armature: stainless iron

Stem tube: stainless steel

Springs: stainless steel

Seals: nitrile rubber (viton top seat)

Alternative models

Viton (FPM) seal material

Replacement coils

2 wire electrical flying leads

Table B DIN 43650 electrical connections

30 mm low power coils with Table A DIN 43650 electrical connections

Vacuum operation

Zero power latching (impulse) valves

Non standard a.c. and d.c. voltages up to + 30% tolerance

Connector plugs – order separately



Function	Orifice (mm)	Operating pressure (bar)	Power (W)	Manual override	Model
2/2 NC	2,0	10	6 or 7,5 / 8	None	33804120/**
2/2 NC	2,0	3	3,4 / 2,5 or 5	None	35804120/**
3/2 NC	2,0	6	6 or 7,5 / 8	None	31804720/**
3/2 NC	2,0	3	3,4 / 2,5 or 5	None	34804720/**

** Insert voltage code from table below

Voltage codes

Supply d.c.	Power (W)	Code
12 V	7,5	CB
	3,4	BB
24 V	6	PC
	3,4	BC

Other voltages on request.

a.c. voltages are available. Please consult our Technical Service for details.

Electrical information

Voltage tolerance	±10% as standard
d.c. Power	3,4, 7,5 W (6 W for 24 V d.c. high power coils)
Typical electrical response time	On 10 to 20 ms Off 5 to 10 ms
Protection class	IP 65 (DIN 40 050) with connector plug fitted
Electrical duty	100% (Continuously rated)
Coil	22 mm removable encapsulated
Electrical connections	3 flat pin (Industrial standard)
Connector plug	Supplied without plug. Order separately.
Manual override	None

Webber Excel 22 Hosetail

22 mm Direct acting solenoid valve

In-line

2,0 mm orifice (ND)

2/2, 3/2, NC, 6 mm hosetail

2/2

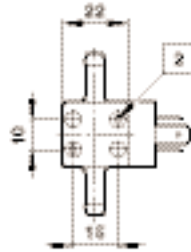

3/2

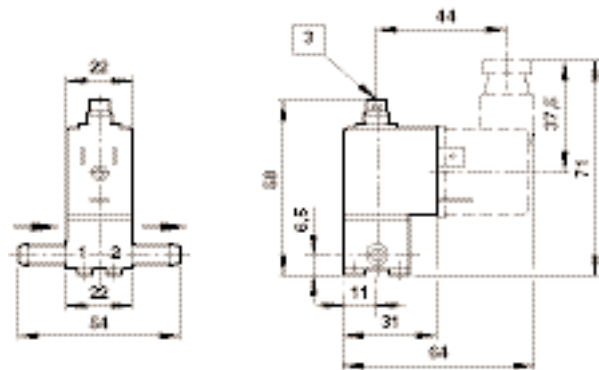
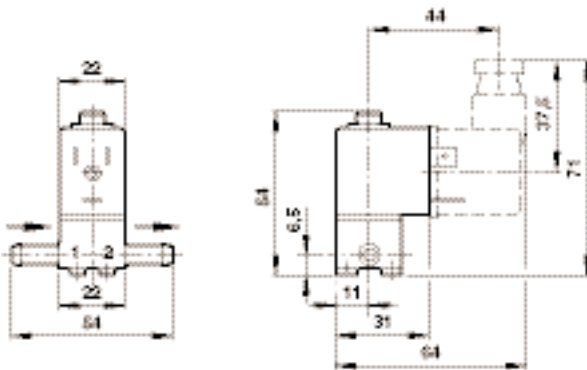
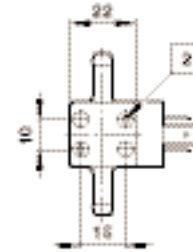

2 2 holes to suit no. 4 Plasform screws

3 Port 3



2/2 & 3/2 Solenoid operated valves

Webber Excel 32 V03, V04 and V05 Series

32 mm Direct acting solenoid valves

Sub-base mounted

1,0 mm to 2,5 mm orifice

2/2 & 3/2, NC/NO

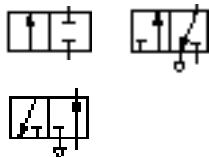
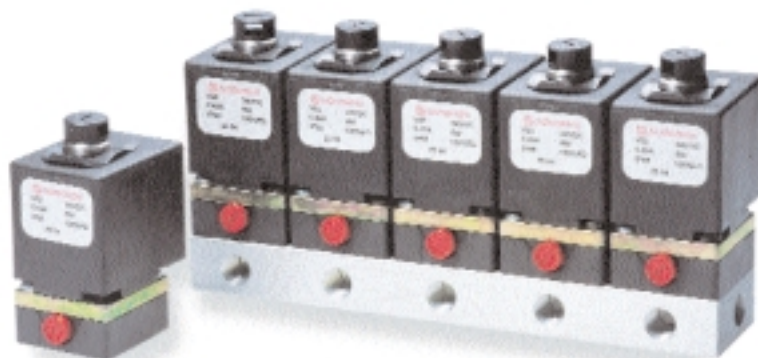

Extensive range of power and orifice size options

G1/8, G1/4, 7 mm interface

Compact installation

Removeable coil

Standard exhaust diffuser

Choice of manual override

Technical data

Medium:

Compressed air, filtered, lubricated and non lubricated.

Operating pressure:

Maximum 16 bar.

See individual details.

Flow:

Orifice Ø l/min*

1,0 mm 25

2,0 mm 95

2,5 mm 150

* l/min calculation tested at 6 bar in, 5 bar out

Ambient temperature:

-20°C to +50°C.

Consult our Technical Service for use below +2°C

Materials

Coil: glass reinforced nylon

Armature: stainless iron

Tube & spring: stainless steel

Base: glass reinforced polyester

Manifold: aluminium

Seals: nitrile (Viton top seat)

Alternative models

15 mm models, 22 mm models.

Viton seals

Function	Orifice (mm)	Operating pressure (bar)	kg	Mounting	Model
2/2 NC	1,0	0 ... 10	0,20	Interface	V03X286J-B613A
3/2 NC	1,0	0 ... 10	0,20	Interface	V03X486J-B613A
2/2 NC	2,5	0 ... 10	0,20	Interface	V04X286M-B62*A
3/2 NO	2,0	0 ... 10	0,20	Interface	V04X386L-B62*A
3/2 NC	2,0	0 ... 10	0,20	Interface	V04X486L-B62*A
2/2 NC	2,5	0 ... 16	0,20	Interface	V05X286M-B63*A
3/2 NO	2,5	0 ... 10	0,20	Interface	V05X386M-B63*A
3/2 NC	2,5	0 ... 10	0,20	Interface	V05X486M-B63*A

V03 models are only available with 24 V d.c. coil. Spare coil part no. V03X286A-Q1213.

* Insert voltage codes from table below. All models are available without manual override. Change 10th digit to 1 eg. V04A486L-B12*A.

Other orifices are available. Contact our Technical Service for details. Service kits are not available for these valves. Order connector plugs separately.

Voltage codes & spare coils - V04 & V05

Voltage	Code	Coil	
		V04	V05
6 V d.c.	1	V04X286A-Q1221	V05X286A-Q1231
12 V d.c.	2	V04X286A-Q1222	V05X286A-Q1232
24 V d.c.	3	V04X286A-Q1223	V05X286A-Q1233
48 V d.c.	5	V04X286A-Q1225	V05X286A-Q1235
110 V d.c.	7	V04X286A-Q1227	V05X286A-Q1237
24 V 50/60 Hz	4	V04X286A-Q1224	V05X286A-Q1234
48 V 50/60 Hz	6	V04X286A-Q1226	V05X286A-Q1236
110 ... 120 V 50/60 Hz	8	V04X286A-Q1228	V05X286A-Q1238
220 ... 240 V 50/60 Hz	9	V04X286A-Q1229	V05X286A-Q1239

Electrical details for solenoid operators

Voltage tolerance:	±10%
Power consumption:	Excel V03 d.c. 1,0 W
Inrush/hold:	Excel V04 d.c. 4,5 W
	Excel V05 d.c. 9,0 W
	a.c. 14/10 V A
	a.c. 27/20 V A
Rating:	100% E.D.
Electrical connection:	3 pin plug (DIN 43 650 Form A)
	Coil may be rotated at 90° intervals
Manual override:	Screwdriver operated, memory type, standard
Protection class:	IP 65 (DIN 40 050) with terminal box fitted

For details of connector plugs and indicators please contact our Technical Service

Interface mounted valves

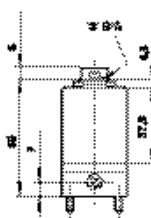
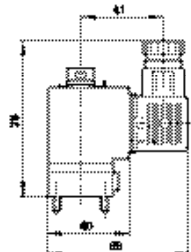
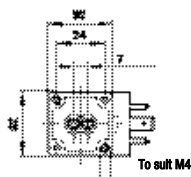

Manifold for use with interface valves - M/P35598/

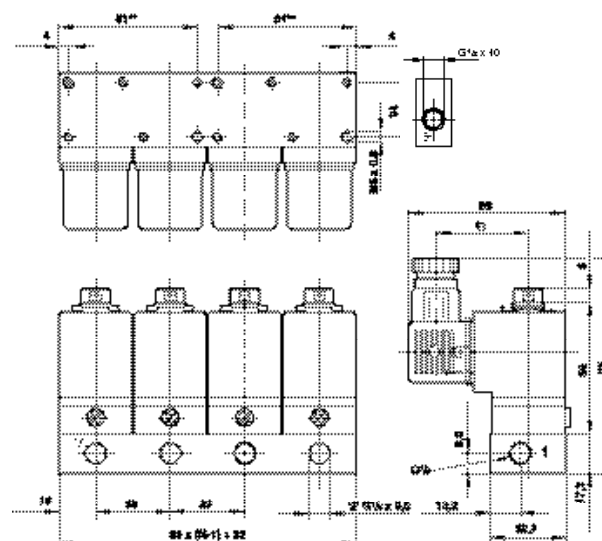

‡ Indicates the number of stations: 1 to 20. N = number of stations

** Two additional holes with five or more stations. Weight: 0,041 kg/station.

Accessories

Blanking plate - QM/7600/23

Manifold assemblies are available. Contact our Technical Service for details.

Webber Excel 32 V03, V04 and V05 Series

32 mm Direct acting solenoid valves

In-line

1,0 mm to 3,0 mm orifice

2/2 & 3/2, G $\frac{1}{8}$, G $\frac{1}{4}$

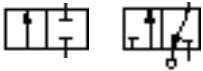
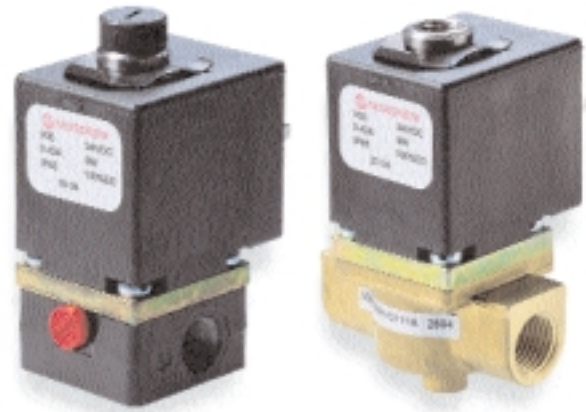

Extensive range of power and orifice size options

Compact installation

Removeable coil

Standard exhaust diffuser

Choice of manual override

Technical data

Medium:

Compressed air, filtered, lubricated and non lubricated.

Operating pressure:

Maximum 16 bar.

See individual details.

Flow:

Orifice Ø l/min

1,0 mm 30

1,5 mm 70

2,0 mm 120

2,5 mm 190

3,0 mm 260

Ambient temperature:

-20°C to +50°C.

Consult our Technical Service for use below +2°C

Materials

Coil: glass reinforced nylon

Armature: stainless iron

Tube & spring: stainless steel

Base: zinc alloy (G $\frac{1}{8}$), brass (G $\frac{1}{4}$)

Seals: nitrile (Viton top seat)

Alternative models

15 mm models, 22 mm models.

Viton seals

Function	Orifice (mm)	Operating pressure (bar)	kg	Mounting	Model
2/2 NC	1,0	0 ... 10	0,24	G1/8	V03A286J-B613A #
3/2 NC	1,0	0 ... 10	0,24	G1/8	V03A486J-B613A #
3/2 NC	2,0	0 ... 10	0,24	G1/8	V04A486L-B62*A
3/2 NO	2,0	0 ... 10	0,24	G1/8	V04A386L-B62*A
2/2 NC	2,5	0 ... 10	0,24	G1/8	V04A286M-B62*A
2/2 NC	2,5	0 ... 16	0,24	G1/8	V05A286M-B63*A
3/2 NC	2,5	0 ... 10	0,24	G1/8	V05A486M-B63*A
3/2 NO	2,5	0 ... 10	0,24	G1/8	V05A386M-B63*A
2/2 NC	2,5	0 ... 10	0,32	G1/4	V04B286M-B42*A
2/2 NC	2,5	0 ... 16	0,32	G1/4	V05B286M-B43*A
2/2 NC	3,0	0 ... 7	0,32	G1/4	V04B286N-B42*A
2/2 NC	3,0	0 ... 13	0,32	G1/4	V05B286N-B43*A

V03 models are only available with 24 V d.c. coil. Spare coil part no. V03X286A-Q1213.

* Insert voltage codes from table below. All models are available without manual override. Change 10th digit to 1 eg. V04A486L-B12*A.

Other orifices are available. Contact our Technical Service for details. Service kits are not available for these valves. Order connector plugs separately.

Voltage codes & spare coils - V04 & V05

Voltage	Code	Coil	
		V04	V05
6 V d.c.	1	V04X286A-Q1221	V05X286A-Q1231
12 V d.c.	2	V04X286A-Q1222	V05X286A-Q1232
24 V d.c.	3	V04X286A-Q1223	V05X286A-Q1233
48 V d.c.	5	V04X286A-Q1225	V05X286A-Q1235
110 V d.c.	7	V04X286A-Q1227	V05X286A-Q1237
24 V 50/60 Hz	4	V04X286A-Q1224	V05X286A-Q1234
48 V 50/60 Hz	6	V04X286A-Q1226	V05X286A-Q1236
110 ...120 V 50/60 Hz	8	V04X286A-Q1228	V05X286A-Q1238
220 ... 240 V 50/60 Hz	9	V04X286A-Q1229	V05X286A-Q1239

Electrical details for solenoid operators

Voltage tolerance:	±10%
Power consumption:	Excel V03 d.c. 1,0 W
Inrush/hold:	Excel V04 d.c. 4,5 W
	Excel V05 a.c. 14/10 V A
	d.c. 9,0 W
	a.c. 27/20 V A
Rating:	100% E.D.
Electrical connection:	3 pin plug (DIN 43 650 Form A)
	Coil may be rotated at 90° intervals
Manual override:	G1/8 Screwdriver operated, memory type standard
	G1/4 Lever operated memory type standard
Protection class:	IP 65 (DIN 40 050) with terminal box fitted

For details of connector plugs and indicators please contact our Technical Service

G1/8 Valves

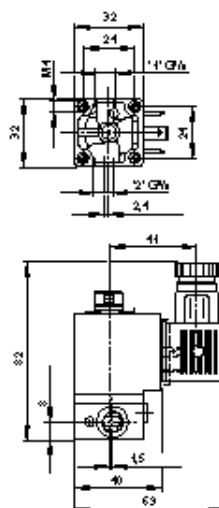

G1/4 Valves

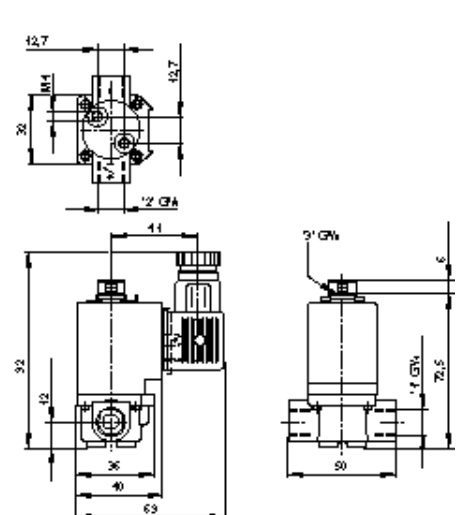

2/2 & 3/2 Solenoid operated valves

Buschjost 82400 / 82410 Series

Indirect solenoid actuated diaphragm valves

8 to 50 mm orifice (ND)

2/2, NC, G¼ to G2 / ¼ NPT to 2 NPT

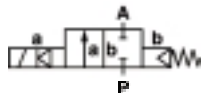

High flow rate

Damped operation

Clear compact design

Solenoid interchangeable without tools (Click-on®)

Particularly suitable for use as water valve in accordance with DIN EN 60730-2-8



Technical data

Medium:

Neutral gases and liquid fluids

Viscosity:

25 mm²/s (cSt) max.

Flow direction:

Fixed

Mounting position:

Optional, preferably with solenoid upright

Fluid temperature:

-10°C to +90°C max.

Ambient temperature:

+50°C max.

Consult our Technical Service for use below +2°C

Materials

Body: brass

Seat seal: NBR (Perbunan)

Internal parts: stainless steel, PVDF

For contaminated fluids installation of an upstream filter is recommended.

Orifice (mm)	Port size	Operating pressure (bar)	kv value m ³ /h*	Total weight (kg)	Type d.c. or a.c. solenoid
8	G 1/4	0,1 ... 16	1,90	0,47	8240000xxxx*****
10	G 3/8	0,1 ... 16	3,00	0,45	8240100xxxx*****
12	G 1/2	0,1 ... 16	3,80	0,50	8240200xxxx*****
20	G 3/4	0,1 ... 16	6,10	0,65	8240300xxxx*****
25	G 1	0,1 ... 16	9,50	0,95	8240400xxxx*****
32	G 1¼	0,1 ... 10 (16**)	23,00	2,73	8240500xxxx*****
40	G 1½	0,1 ... 10 (16**)	25,00	2,53	8240600xxxx*****
50	G 2	0,1 ... 10 (16**)	41,00	3,85	8240700xxxx*****
8	1/4 NPT	0,1 ... 16	1,90	0,47	8241000xxxx*****
10	3/8 NPT	0,1 ... 16	3,00	0,45	8241100xxxx*****
12	1/2 NPT	0,1 ... 16	3,80	0,50	8241200xxxx*****
20	3/4 NPT	0,1 ... 16	6,10	0,65	8241300xxxx*****
25	1 NPT	0,1 ... 16	9,50	0,95	8241400xxxx*****
32	1¼ NPT	0,1 ... 10 (16**)	23,00	2,73	8241500xxxx*****
40	1½ NPT	0,1 ... 10 (16**)	25,00	2,53	8241600xxxx*****
50	2 NPT	0,1 ... 10 (16**)	41,00	3,85	8241700xxxx*****

xxxx Insert solenoid codes from table below. ***** Insert voltage codes from table below

* Cv (US) ≈ kv x 1,2

** Operating pressure max. 16 bar with solenoid 9151.

Type-tested up to 25 mm orifice size in accordance with DIN EN 60730-2-8

Solenoid valves

Test institute

TÜV Rheinland / Brandenburg



Options selector

824XX *** *****

Alternative versions	Substitute
Normally open (NO), from G 1¼ with solenoid 9151; 0,1 to 16 bar	01
Manual override	02
Seat seal material FPM, max. fluid temperature +110°C	03
Seat seal material EPDM, for hot water, max. fluid temperature +110°C; 0,3 to 16 bar up to 25 mm, 0,3 to 10 bar from 32 mm	14
Bistable solenoid system; Current pulse min. 30 ms; only for d.c. 6, 12 and 24 V	50

Voltage	Substitute
24 V d.c.	02400
24 V a.c. 50 Hz	02450
110 V a.c. 50 Hz	11050
230 V a.c. 50 Hz	23050

Other voltages on request

Solenoid	Substitute
d.c./a.c. (G¼ to G2)	9101
d.c./a.c. (G1¼ to G2)	9151
EEx m II T4	9136

Buschjost 85300 / 85310 Series 'Click-on'®

Solenoid actuated angle seat valves with forced lifting

8 to 50 mm orifice (ND)

2/2, NC, G ¼ to G 2 / ¼ NPT to 2 NPT

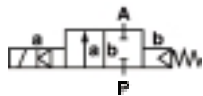

Compact piston valve

High flow rate

Damped operation

Simple compact design

Solenoid in Click-on® design

Stainless steel piston bushing

Technical data

Medium:

Neutral gases and liquid fluids

Viscosity:

40 mm²/s (cSt) max.

Flow direction:

Fixed

Mounting:

Optional, but preferably with solenoid facing vertically upwards

Fluid temperature:

-10°C to +90°C max.

Ambient temperature:

-10°C to +50°C max.

Consult our Technical Service for use below +2°C

Materials

Body: brass

Seat seal: NBR (Perbunan)

Internal parts: stainless steel, brass, PTFE

For contaminated fluids installation of an upstream filter is recommended.



Orifice (mm)	Port size	Operating pressure (bar)	kv value m ³ /h*	Total weight (kg)	Type d.c. or a.c. solenoid
8	G 1/4	0,5 ... 40	2,2	0,83	853000xxxx*****
10	G 3/8	0,5 ... 40	3,4	0,82	853010xxxx*****
12	G 1/2	0,5 ... 40	4,4	0,85	853020xxxx*****
20	G 3/4	0,5 ... 40	7,0	1,25	853030xxxx*****
25	G 1	0,5 ... 40	10,5	1,70	853040xxxx*****
32	G 1¼	0,5 ... 40	25,0	4,10	853050xxxx*****
40	G 1½	0,5 ... 40	27,0	3,85	853060xxxx*****
50	G 2	0,5 ... 40	43,0	5,60	853070xxxx*****
8	1/4 NPT	0,5 ... 40	2,2	0,83	853100xxxx*****
10	3/8 NPT	0,5 ... 40	3,4	0,82	853110xxxx*****
12	1/2 NPT	0,5 ... 40	4,4	0,85	853120xxxx*****
20	3/4 NPT	0,5 ... 40	7,0	1,25	853130xxxx*****
25	1 NPT	0,5 ... 40	10,5	1,70	853140xxxx*****
32	1¼ NPT	0,5 ... 40	25,0	4,10	853150xxxx*****
40	1½ NPT	0,5 ... 40	27,0	3,85	853160xxxx*****
50	2 NPT	0,5 ... 40	43,0	5,60	853170xxxx*****

xxxx Insert solenoid codes from table below. ***** Insert voltage codes from table below

* Cv (US) ≈ kv x 1,2

Options selector

8530X ** ★★ ★★ ★★ ★★ ★★

Alternative versions	Substitute	Voltage	Substitute
Normally open (NO)	01	24 V d.c.	02400
Manual override	02	24 V a.c. 50 Hz	02450
Seat seal material FPM, fluid temperature +110°C max.	03	110 V a.c. 50 Hz	11050
Seat seal material EPDM for hot water, temperature +110°C max	14	230 V a.c. 50 Hz	23050
Other voltages on request			
Solenoid	Substitute		
d.c./a.c.	9151		

Buschjost 85300 / 85310 Series 'Click-on'[®]

Solenoid actuated angle seat valves with forced lifting

8 to 50 mm orifice (ND)

2/2, NC, G¼ to G 2 / ¼ NPT to 2 NPT

Electrical details for solenoid operators

	Power consumption		Voltage		Category	Protection class	Temperatures °C		Electrical connection	kg	Solenoid drawing no.#	Circuit diagram#		Model
	24 V d.c. (W)	230 V a.c. (VA)	24 V d.c. (mA)	230 V a.c. (mA)			Fluid*	Ambient**				d.c.	a.c.	
	18	45/35	750	152	-	IP 65	+110 max	-25 ... +50	DIN EN 175301-803	0,40	24	1	1	9151

* The maximum temperature depends on the valve type

** The maximum temperature may be higher, depending on the application.

According to VDE 0580, 100% rated

Power consumption calculated with coil at +20°C, for d.c. coils at operating temperature, power consumption is up to 30% lower

For solenoid dimensional drawings and circuit diagrams, see page 97

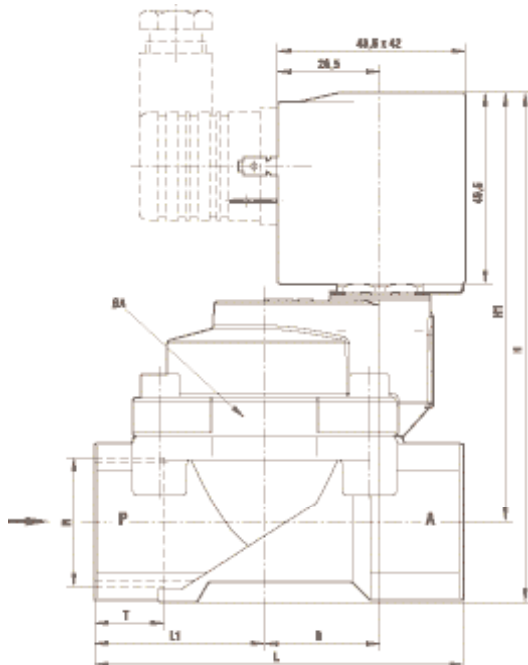

Solenoid rotates 360°
Device socket can be turned through 4 x 90°
(device socket supplied with product)

Model	Ø A	B	H	H1	L	L1	R	T
8530000xxxx******	44	19,5	105,0	93,5	60	27,5	G 1/4	12,0
8531000xxxx******	44	19,5	105,0	93,5	60	27,5	1/4 NPT	10,0
8530100xxxx******	44	19,5	105,0	93,5	60	27,5	G 3/8	12,0
8531100xxxx******	44	19,5	105,0	93,5	60	27,5	3/8 NPT	10,5
8530200xxxx******	44	19,5	107,5	93,5	67	31,0	G 1/2	14,0
8531200xxxx******	44	19,5	107,5	93,5	67	31,0	1/2 NPT	13,5
8530300xxxx******	50	24,0	119,0	102,5	80	36,5	G 3/4	16,0
8531300xxxx******	50	24,0	119,0	102,5	80	36,5	3/4 NPT	14,0
8530400xxxx******	62	29,5	131,5	110,5	95	44,0	G 1	18,0
8531400xxxx******	62	29,5	131,5	110,5	95	44,0	1 NPT	17,0
8530500xxxx******	92	44,5	166,0	137,0	132	60	G 1½	20,0
8531500xxxx******	92	44,5	166,0	137,0	132	60	1½ NPT	17,0
8530600xxxx******	92	44,5	166,0	137,0	132	60	G 1½	22,0
8531600xxxx******	92	44,5	166,0	137,0	132	60	1½ NPT	17,0
8530700xxxx******	109	54,5	186,0	151,5	160	74	G 2	24,0
8531700xxxx******	109	54,5	186,0	151,5	160	74	2 NPT	17,5

Buschjost 83620 / 83630 Series

Indirect solenoid actuated diaphragm valves

10 mm orifice (ND)

2/2, NC, G $\frac{1}{4}$ to G $\frac{3}{8}$

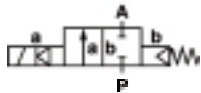

Compact design

Up to 8 valves can be supplied as manifold

Simpler installation compared with conventional piping

Comprehensive range of accessories

Can be combined with directly controlled valves from series 83600 / 83610

Valves can be positioned as required at right angles to the manifold

Technical data

Medium:

Neutral gases and liquid fluids

Viscosity:

25 mm²/s (cSt) max.

Flow direction:

Fixed

Mounting:

Optional, but preferably with solenoid facing vertically upwards

Fluid temperature:

+90°C max.

Ambient temperature:

+50°C max.

Consult our Technical Service for use below +2°C

Sum of fluid and ambient temperatures:

+130°C

Materials

Body: brass

Seat seal: NBR, diaphragm

Internal parts: stainless steel

1.4104/430F, 1.4301

For contaminated fluids installation of an upstream filter is recommended.



Orifice (mm)	Port size	Operating pressure (bar)	kv value m ³ /h*	Total weight (kg)	Type d.c. or a.c. solenoid
10	P: G 3/8, A: G 1/4	0,1 ... 10	1,5	0,5	8362100xxxx*****
10	P: G 3/8, A: G 3/8	0,1 ... 10	1,7	0,5	8363100xxxx*****

xxxx Insert solenoid codes from table below. ***** Insert voltage codes from table below

* Cv (US) ≈ kv x 1,2

Note: individual valves are not supplied with a blanking plug and hexagonal nut for manifold mounting.

Options selector

836XX ** * * * * *

Alternative versions	Substitute
Seat seal material FPM, preferably for fuels and oils, fluid temperature +110°C max.	03
Seat seal material EPDM, for hot water, fluid temperature +110°C max.	14
Solenoid	Substitute
d.c./a.c.	8001

Voltage	Substitute
24 V d.c.	02400
24 V a.c. 50 Hz	02450
110 V a.c. 50 Hz	11050
230 V a.c. 50 Hz	23050

Other voltages on request

Buschjost 83620 / 83630 Series

Indirect solenoid actuated diaphragm valves

10 mm orifice (ND)

2/2, NC, G $\frac{1}{4}$ to G $\frac{3}{8}$

Electrical details for solenoid operators

	Power consumption		Voltage		Category	Protection class	Temperatures °C		Electrical connection	kg	Solenoid drawing no.#	Circuit diagram#		Model
	24 V d.c. (W)	230 V a.c. (VA)	24 V d.c. (mA)	230 V a.c. (mA)			Fluid*	Ambient**				d.c.	a.c.	
	12/12	20/16	500	70	-	IP 65	+110 max..	-25 ... +50	DIN EN 175301-803	0,22	16	1	1	8001

Version as per VDE 0580, duty cycle 100%. Voltage tolerance $\pm 10\%$

* The maximum temperature depends on the valve type

** The maximum temperature may be higher, depending on the application.

For solenoid dimensional drawings and circuit diagrams, see page 97

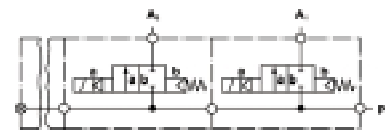
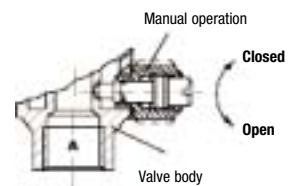
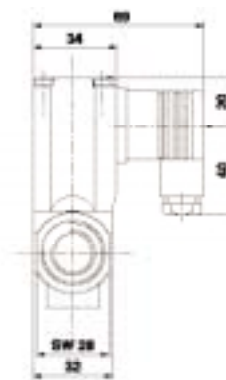
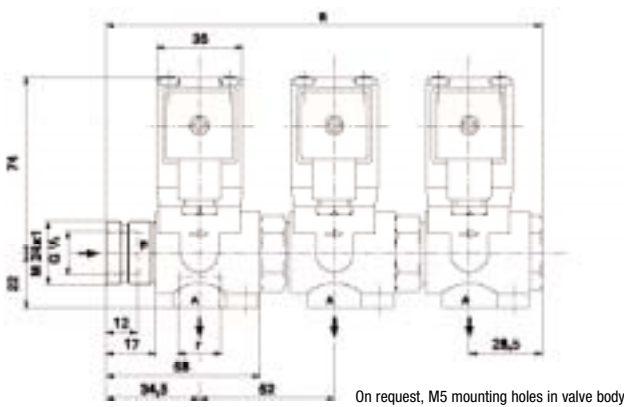

Symbol for horizontal manifold

	8362100.8001	8363100.8001	836X200.8001	836X300.8001	836X400.8001	836X500.8001	836X600.8001	836X700.8001	836X800.8001
Number of valves	1	1	2	3	4	5	6	7	8
a	-	-	115	167	219	271	323	375	427
r	G 1/4	G 3/8							

Replace X with 2 or 3 for port A = G 1/4 or G 3/8

Accessories

Mounting components

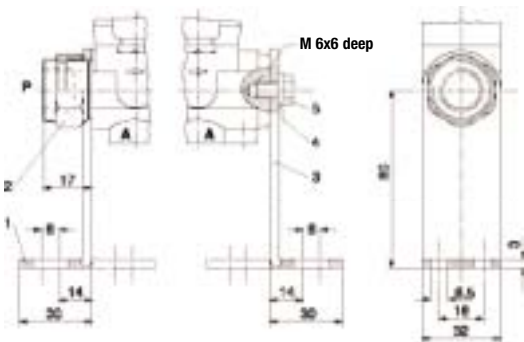

Part no. 1241203, consisting of:

- 1 Bracket
- 2 Hexagon nut
- 3 Bracket
- 4 Washer
- 5 Hexagon screw

Enlarged pressure connection P = G 3/4

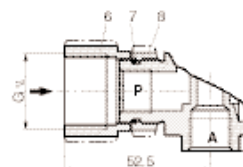

If assembly without bracket:

Part no. 1241438,

consisting of:

- 6 Adapter
- 7 O-ring
- 8 Hexagon nut

If assembly with bracket:

Part no. 1241104,

consisting of:

- 6 Adapter
- 7 O-ring

Buschjost 82470 Series 'Click-on'[®]

Indirect solenoid actuated diaphragm valves

8 to 25 mm orifice (ND)

2/2, NC, G¹/₄ to G1

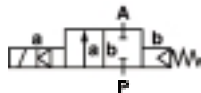

High flow rate

Damped operation

Clear compact design

Solenoid interchangeable without tools (Click-on[®])

Technical data

Medium:

e.g. hot water and steam

Viscosity:

25 mm²/s (cSt) max.

Flow direction:

Fixed

Mounting:

Optional, preferably with solenoid upright

Fluid temperature:

+150°C max.

Ambient temperature:

+60°C max.

Consult our Technical Service for use below +2°C

Materials

Body: brass

Seat seal: HNBR

Internal parts: stainless steel, brass

For contaminated fluids installation of an upstream filter is recommended.



Orifice (mm)	Port size	Operating pressure (bar)	kv value m ³ /h*	Total weight (kg)	Type d.c. or a.c. solenoid
8	G 1/4	0,1 ... 10	1,70	0,47	8247000xxxx*****
10	G 3/8	0,1 ... 10	2,70	0,45	8247100xxxx*****
12	G 1/2	0,1 ... 10	3,40	0,50	8247200xxxx*****
20	G 3/4	0,1 ... 10	5,50	0,65	8247300xxxx*****
25	G 1	0,1 ... 10	8,50	0,95	8247400xxxx*****

xxxx Insert solenoid codes from table below. ***** Insert voltage codes from table below
 * Cv (US) ≈ kv x 1,2

Type-tested up to 25 mm orifice size in accordance with DIN EN 60730-2-8 Solenoid valves Test institute TÜV Rheinland / Brandenburg



Options selector

8247X ** ★★★★★ ★★★★★

Alternative versions	Substitute	Voltage	Substitute
Normally open	01	24 V d.c.	02400
		24 V a.c. 50 Hz	02450
		110 V a.c. 50 Hz	11050
		230 V a.c. 50 Hz	23050

Other voltages on request

Buschjost 82470 Series 'Click-on'[®]

Indirect solenoid actuated diaphragm valves

8 to 25 mm orifice (ND)

2/2, NC, G¼ to G1

Electrical details for solenoid actuators

	Power consumption		Voltage		Category	Protection class	Temperatures °C		Electrical connection	kg	Solenoid drawing no.#	Circuit diagram#		Model
	24 V d.c. (W)	230 V a.c. (VA)	24 V d.c. (mA)	230 V a.c. (mA)			Fluid*	Ambient**				d.c.	a.c.	
	8	15/12	333	52	-	IP 65	+110 max.	-25 ... +50	DIN EN 175301-803	0,15	17	1	1	9101

* The maximum temperature depends on the valve type

** The maximum temperature may be higher, depending on the application.

According to VDE 0580, 100% rated

Power consumption calculated with coil at +20°C, for d.c. coils at operating temperature, power consumption is up to 30% lower

For solenoid dimensional drawings and circuit diagrams, see page 97

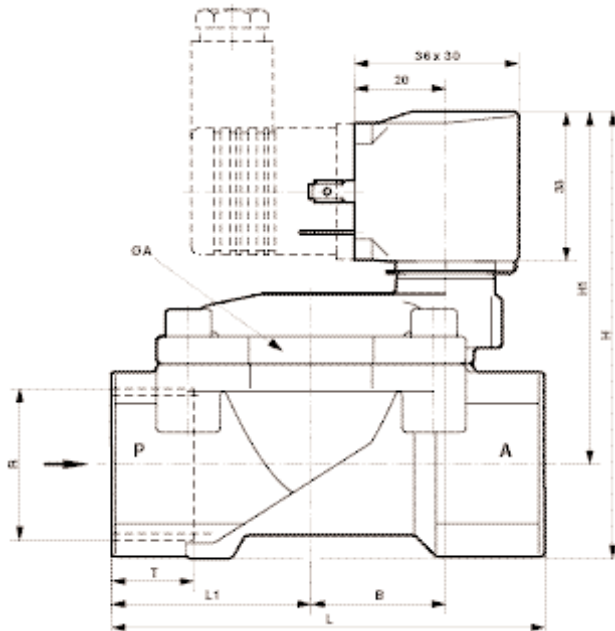

Solenoid rotates 360°

Device socket can be turned through 4 x 90° (device socket supplied with product)

Model	Ø A	B	H	H1	L	L1	R	T
8247000xxxx*****	44	19,5	78,5	67	60	27,5	G 1/4	12,0
8247100xxxx*****	44	19,5	78,5	67	60	27,5	G 3/8	12,0
8247200xxxx*****	44	19,5	81,0	67	67	31,0	G 1/2	14,0
8247300xxxx*****	50	24,0	88,0	71,5	80	36,5	G 3/4	16,0
8247400xxxx*****	62	29,5	97,5	77	95	44,0	G 1	18,0

Buschjost 85320 Series 'Click-on'[®]

Indirect solenoid actuated spool valves

8 to 25 mm orifice (ND)

2/2, NC, G $\frac{1}{4}$ to G1 / $\frac{1}{4}$ NPT to 1 NPT

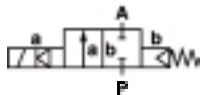

Compact piston valve

High flow rate

Damped operation

Simple compact design

Solenoid in Click-on[®] design

Stainless steel piston bushing

Technical data

Medium:

e.g. Hot water and steam

Viscosity:

40 mm²/s (cSt) max.

Flow direction:

Fixed

Mounting:

Optional, but preferably with solenoid facing vertically upwards

Fluid temperature:

-10°C to +200°C max.

Ambient temperature:

-10°C to +50°C max.

Consult our Technical Service for use below +2°C

Materials

Body: brass

Seat seal: PTFE

Internal parts: stainless steel, FPM, PTFE

For contaminated fluids installation of an upstream filter is recommended.



Orifice (mm)	Port size	Operating pressure (bar)	kv value m ³ /h*	Total weight (kg)	Type d.c. or a.c. solenoid
8	G 1/4	1 ... 25	2,2	0,83	8532000xxxx*****
10	G 3/8	1 ... 25	3,4	0,82	8532100xxxx*****
12	G 1/2	1 ... 25	4,4	0,85	8532200xxxx*****
20	G 3/4	1 ... 25	7	1,25	8532300xxxx*****
25	G 1	1 ... 25	10,5	1,7	8532400xxxx*****
8	1/4 NPT	1 ... 25	2,2	0,83	8533000xxxx*****
10	3/8 NPT	1 ... 25	3,4	0,82	8533100xxxx*****
12	1/2 NPT	1 ... 25	4,4	0,85	8533200xxxx*****
20	3/4 NPT	1 ... 25	7	1,25	8533300xxxx*****
25	1 NPT	1 ... 25	10,5	1,7	8533400xxxx*****

xxxx Insert solenoid codes from table below. ***** Insert voltage codes from table below

* Cv (US) ≈ kv x 1,2

Options selector

853XX ** * * * * *

Alternative versions	Substitute	Voltage	Substitute
Normally open (NO), operating pressure 1 to 16 bar	01	24 V d.c.	02400
Manual override	02	24 V a.c. 50 Hz	02450
		110 V a.c. 50 Hz	11050
		230 V a.c. 50 Hz	23050
Solenoid	Substitute	Other voltages on request	
d.c./a.c.	9152		

Buschjost 85320 Series 'Click-on'[®]

Indirect solenoid actuated spool valves

8 to 25 mm orifice (ND)

2/2, NC, G¹/₄ to G1 / ¹/₄ NPT to 1 NPT

Electrical details for solenoid operators

	Power consumption		Voltage		Category	Protection class	Temperatures °C		Electrical connection	kg	Solenoid drawing no.#	Circuit diagram#		Model
	24 V d.c. (W)	230 V a.c. (VA)	24 V d.c. (mA)	230 V a.c. (mA)			Fluid*	Ambient**				d.c.	a.c.	
	10	15 VA/10 W	417	48	-	IP 65	+200 max.	-25 ... +60	DIN EN 175301-803	0,40	24	1	1	9152

* The maximum temperature depends on the valve type

** The maximum temperature may be higher, depending on the application.

According to VDE 0580, 100% rated

Power consumption calculated with coil at +20°C, for d.c. coils at operating temperature, power consumption is up to 30% lower

For solenoid dimensional drawings and circuit diagrams, see page 97

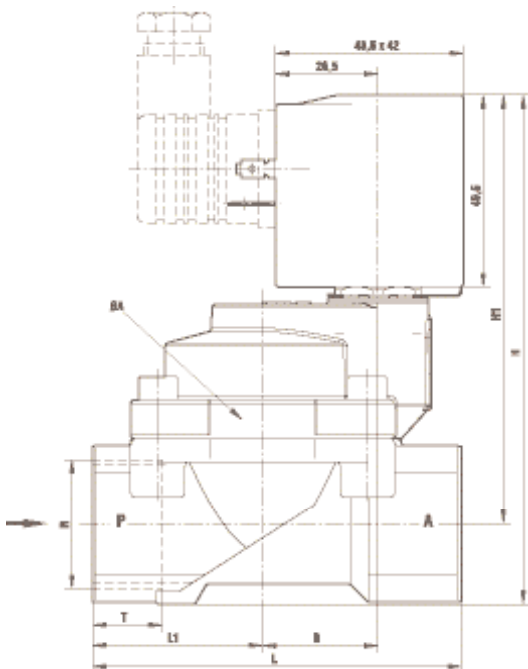

Solenoid rotates 360°

Device socket can be turned through 4 x 90°
(device socket supplied with product)

Model	Ø A	B	H	H1	L	L1	R	T
8532000xxx*****	44	19,5	105	93,5	60	27,5	G 1/4	12
8533000xxx*****	44	19,5	105	93,5	60	27,5	1/4 NPT	10
8532100xxx*****	44	19,5	105	93,5	60	27,5	G 3/8	12
8533100xxx*****	44	19,5	105	93,5	60	27,5	3/8 NPT	10,5
8532200xxx*****	44	19,5	107,5	93,5	67	31	G 1/2	14
8533200xxx*****	44	19,5	107,5	93,5	67	31	1/2 NPT	13,5
8532300xxx*****	50	24	119	102,5	80	36,5	G 3/4	16
8533300xxx*****	50	24	119	102,5	80	36,5	3/4 NPT	14
8532400xxx*****	62	29,5	131,5	110,5	95	44	G 1	18
8533400xxx*****	62	29,5	131,5	110,5	95	44	1 NPT	17

2/2 & 3/2 Solenoid operated valves

Buschjost 82730 / 82740 Series

Indirect solenoid actuated diaphragm valves

8 to 25 mm orifice (ND)

2/2, NC, G¼ to G1 / ¼ NPT to 1 NPT

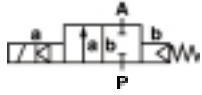

High flow rate

Damped operation

Simple compact design

Solenoid interchangeable without tools (Click-on®)

Technical data

Medium:

Semi-aggressive gases and liquids

Viscosity:

25 mm²/s (cSt) max.

Flow direction:

Fixed

Mounting:

Optional, but preferably with solenoid facing vertically upwards

Fluid temperature:

-10°C to +90°C max.

Ambient temperature:

-10°C to +50°C max.

Consult our Technical Service for use below +2°C

Materials

Body: stainless steel 1.4408

Seat seal: NBR (Perbunan)

Internal parts: stainless steel, PVDF

For contaminated fluids installation of an upstream filter is recommended.

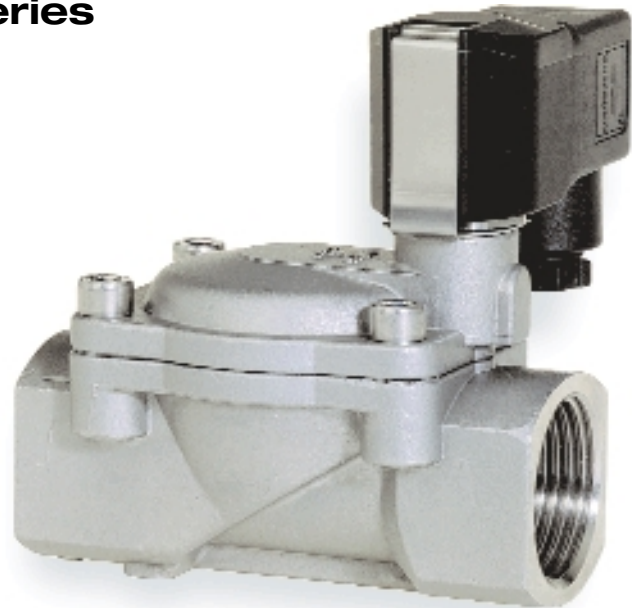

Orifice (mm)	Port size	Operating pressure (bar)	kv value m ³ /h*	Total weight (kg)	Model
8	G 1/4	0,1 ... 16	1,90	0,47	8273000xxxx*****
10	G 3/8	0,1 ... 16	3,00	0,45	8273100xxxx*****
12	G 1/2	0,1 ... 16	3,80	0,50	8273200xxxx*****
20	G 3/4	0,1 ... 16	6,10	0,65	8273300xxxx*****
25	G 1	0,1 ... 16	9,50	0,95	8273400xxxx*****
8	1/4 NPT	0,1 ... 16	1,90	0,47	8274000xxxx*****
10	3/8 NPT	0,1 ... 16	3,00	0,45	8274100xxxx*****
12	1/2 NPT	0,1 ... 16	3,80	0,50	8274200xxxx*****
20	3/4 NPT	0,1 ... 16	6,10	0,65	8274300xxxx*****
25	1 NPT	0,1 ... 16	9,50	0,95	8274400xxxx*****

xxxx Insert solenoid codes from table below. ***** Insert voltage codes from table below

* Cv (US) ≈ kv x 1,2

Options selector

827XX ★★ ★★★★★ ★★★★★★

Alternative versions	Substitute
Normally open (NO)	01
Seat seal material FPM, max. fluid temperature +110°C	03
Seat seal material EPDM, for hot water, max. fluid temperature +110°C; 0,3 to 16 bar up to ND 25 mm	14
Solenoid sleeve free of non-ferrous metals, seat seal material FPM, fluid temperature max. 110°C, with a.c. supply, solenoid with rectifier	81

Solenoid	Substitute
d.c./a.c.	9101
a.c.*	9104
EEx m II T4	9136

* Only for alternative version 81

Voltage	Substitute
24 V d.c.	02400
24 V a.c. 50 Hz	02450
110 V a.c. 50 Hz	11050
230 V a.c. 50 Hz	23050

Other voltages on request

Buschjost 82730 / 82740 Series

Indirect solenoid actuated diaphragm valves

8 to 25 mm orifice (ND)

2/2, NC, G $\frac{1}{4}$ to G1 / $\frac{1}{4}$ NPT to 1 NPT

Electrical details for solenoid operators

	Power consumption		Voltage		Category	Protection class	Temperatures °C		Electrical connection	kg	Solenoid drawing no.#	Circuit diagram#		Model
	24 V d.c. (W)	230 V a.c. (VA)	24 V d.c. (mA)	230 V a.c. (mA)			Fluid*	Ambient**				d.c.	a.c.	
	8	15/12	333	52	–	IP 65	+110 max.	-25 ... +50	DIN EN 175301-803	0,15	17	1	1	9101
	8	9 VA/8 W	333	39	–	IP 65	+110 max.	-25 ... +50	DIN EN 175301-803	0,25	17	–	6	9104
	8	9 VA/8 W	333	39	II 2 GD	EEx m II T4, IP67	+80 max.	-20 ... +40	3 m cable	0,40	27	2	6	9136

* The maximum temperature depends on the valve type

** The maximum temperature may be higher, depending on the application.

According to VDE 0580, 100% rated

Power consumption calculated with coil at +20°C, for d.c. coils at operating temperature, power consumption is up to 30% lower

Cable clamping range 5 to 10 mm

Caution! For standard solenoid sleeve with copper ring, check fluid resistance.

For solenoid dimensional drawings and circuit diagrams, see page 97

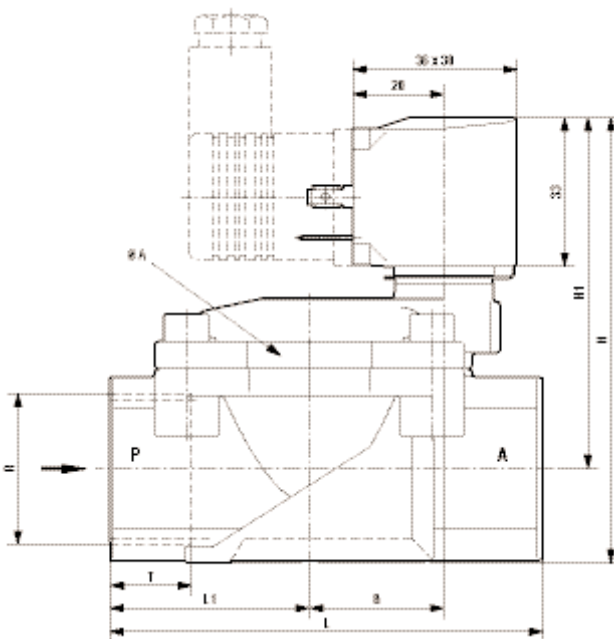

Solenoid rotates 360°

Device socket can be turned through 4 x 90°
(device socket supplied with product)

Model	Ø A	B	H	H1	L	L1	R	T
8273000xxx*****	44	19,5	78,5	67,0	60	27,5	G 1/4	12,0
8274000xxx*****	44	19,5	78,5	67,0	60	27,5	1/4 NPT	10,0
8273100xxx*****	44	19,5	78,5	67,0	60	27,5	G 3/8	12,0
8274100xxx*****	44	19,5	78,5	67,0	60	27,5	3/8 NPT	10,5
8273200xxx*****	44	19,5	81,0	67,0	67	31,0	G 1/2	14,0
8274200xxx*****	44	19,5	81,0	67,0	67	31,0	1/2 NPT	13,5
8273300xxx*****	50	24,0	88,0	71,5	80	36,5	G 3/4	16,0
8274300xxx*****	50	24,0	88,0	71,5	80	36,5	3/4 NPT	14,0
8273400xxx*****	62	29,5	97,5	77,0	95	44,0	G 1	18,0
8274400xxx*****	62	29,5	97,5	77,0	95	44,0	1 NPT	17,0

2/2 & 3/2 Solenoid operated valves

Buschjost 82540 / 82640 Series 'Click-on'[®]

Solenoid actuated diaphragm valves with forced lifting

8 to 50 mm orifice (ND)

2/2, NC, G $\frac{1}{4}$ to G2, $\frac{1}{4}$ NPT to 2 NPT

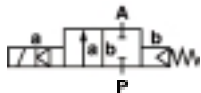

High flow rate

For robust industry solutions

Damped operation

Suitable for vacuum

For systems with low or discontinuous pressure

Solenoid interchangeable without tools (Click-on[®])

Valve operates without differential pressure (Δp)

Technical data

Medium:

Neutral gases and liquid fluids

Viscosity:

25 mm²/s max. (cSt)

Flow direction:

Fixed

Mounting:

Optional, but preferably with solenoid facing vertically upwards

Fluid temperature:

-10°C to +90°C max.

Ambient temperature:

-10°C to +50°C max.

Consult our Technical Service for use below +2°C

Materials

Body: brass

Seat seal: NBR (Perbunan)

Internal parts: stainless steel, PVDF, brass

For contaminated fluids installation of an upstream filter is recommended.



Orifice (mm)	Port size	Operating pressure (bar)	kv value m ³ /h*	Total weight (kg)	Model
8	G 1/4	0 ... 10	1,9	0,79	8254000xxxx*****
10	G 3/8	0 ... 10	3,0	0,77	8254100xxxx*****
12	G 1/2	0 ... 10	3,4	0,80	8254200xxxx*****
20	G 3/4	0 ... 10	5,8	0,97	8254300xxxx*****
25	G 1	0 ... 10	8,0	1,30	8254400xxxx*****
32	G 1 1/4	0 ... 10	23,0	4,30	8254500xxxx*****
40	G 1 1/2	0 ... 10	25,0	4,30	8254600xxxx*****
50	G 2	0 ... 10	41,0	5,40	8254700xxxx*****
8	1/4 NPT	0 ... 10	1,9	0,79	8264000xxxx*****
10	3/8 NPT	0 ... 10	3,0	0,77	8264100xxxx*****
12	1/2 NPT	0 ... 10	3,4	0,80	8264200xxxx*****
20	3/4 NPT	0 ... 10	5,8	0,97	8264300xxxx*****
25	1 NPT	0 ... 10	8,0	1,30	8264400xxxx*****
32	1 1/4 NPT	0 ... 10	23,0	4,30	8264500xxxx*****
40	1 1/2 NPT	0 ... 10	25,0	4,30	8264600xxxx*****
50	2 NPT	0 ... 10	41,0	5,40	8264700xxxx*****

xxxx Insert solenoid codes from table below. ***** Insert voltage codes from table below

* Cv (US) \approx kv x 1,2

Options selector

8254X ★ ★ ★ ★ ★ ★ ★ ★

Alternative versions	Substitute
Normally open (NO)	01
Seat seal material FPM, max. fluid temperature +110°C	03
Seat seal material EPDM, for hot water max. fluid temperature +110°C	14

Solenoid	Substitute
d.c. (G1/4 to G1, 1/4 to 1 NPT)	9151
a.c. (G1/4 to G1, 1/4 to 1 NPT)	9154
d.c. (G1 1/4 to G2, 1 1/4 to 2 NPT)	9401
a.c. (G1 1/4 to G2, 1 1/4 to 2 NPT)	9404
d.c. (G1/4 to G2, 1 1/4 to 2 NPT)*	8401
a.c. (G1/4 to G2, 1 1/4 to 2 NPT)*	8404

* Only in combination with alternative version 01

Voltage	Substitute
24 V d.c.	02400
24 V a.c. 40 to 60 Hz	02449
42 V a.c. 40 to 60 Hz	04249
110 V a.c. 40 to 60 Hz	11049
230 V a.c. 40 to 60 Hz	23049

a.c. version with built-in rectifier

Buschjost 82540 / 82640 Series 'Click-on'[®]

Solenoid actuated diaphragm valves with forced lifting

8 to 50 mm orifice (ND)

2/2, NC, G $\frac{1}{4}$ to G2, $\frac{1}{4}$ NPT to 2 NPT

Electrical details for solenoid operators

	Power consumption		Voltage		Category	Protection class	Temperatures °C		Electrical connection	kg	Solenoid drawing no.#	Circuit diagram#		Model
	24 V d.c. (W)	230 V a.c. (VA)	24 V d.c. (mA)	230 V a.c. (mA)			Fluid*	Ambient**				d.c.	a.c.	
	18	45/35	750	152	-	IP 65	+110 max	-25 ... +50	DIN EN 175301-803	0,40	24	1	1	9151
	-	20 VA/18 W	-	88	-	IP 65	+110 max	-25 ... +50	DIN EN 175301-803	0,40	24	-	6	9154
	38	-	1583	-	-	IP 65	+110 max.	-25 ... +50	DIN EN 175301-803	1,40	25	1	-	9401
	-	42 VA/38 W	-	185	-	IP 65	+110 max.	-25 ... +50	DIN EN 175301-803	1,40	25	-	6	9404
	40	-	1667	-	-	IP 65	+110 max.	-25 ... +50	DIN EN 175301-803	1,70	18	1	-	8401
	-	45 VA/40 W	-	195	-	IP 65	+110 max.	-25 ... +50	DIN EN 175301-803	1,70	18	-	6	8404

* The maximum temperature depends on the valve type

** The maximum temperature may be higher, depending on the application.

According to VDE 0580, 100% rated

Power consumption calculated with coil at +20°C, for d.c. coils at operating temperature, power consumption is up to 30% lower

For solenoid dimensional drawings and circuit diagrams, see page 97

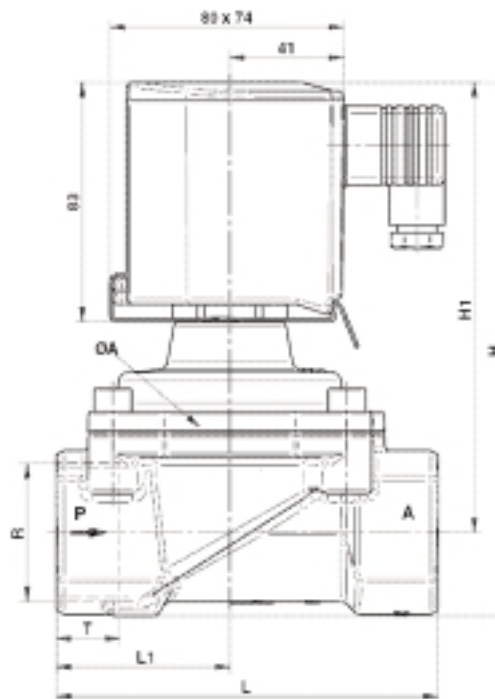
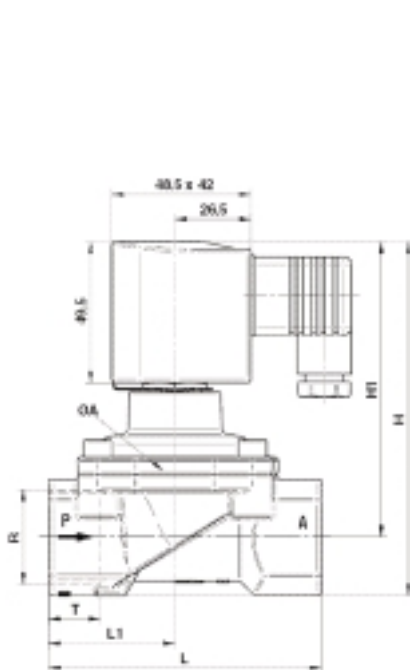

Solenoid rotates 360°
Device socket can be turned through 4 x 90°

Model	Ø A	H	H1	L	L1	R	T
8254000 915x	44	104,0	92,5	60	27,5	G 1/4	12,0
8264000 915x	44	104,0	92,5	60	27,5	1/4 NPT	10,0
8254100 915x	44	104,0	92,5	60	27,5	G 3/8	12,0
8264100 915x	44	104,0	92,5	60	27,5	3/8 NPT	10,5
8254200 915x	44	108,0	94,5	67	31,0	G 1/2	14,0
8264200 915x	44	108,0	94,5	67	31,0	1/2 NPT	13,5
8254300 915x	50	115,0	99,0	80	36,5	G 3/4	16,0
8264300 915x	50	115,0	99,0	80	36,5	3/4 NPT	14,0
8254400 915x	62	124,0	103,5	95	44,0	G 1	18,0
8264400 915x	62	124,0	103,5	95	44,0	1 NPT	17,0
8254500 940x	92	186,0	157,0	132	60,0	G 1 1/4	20,0
8264500 940x	92	186,0	157,0	132	60,0	1 1/4 NPT	17,0
8254600 940x	92	186,0	157,0	132	60,0	G 1 1/2	22,0
8264600 940x	92	186,0	157,0	132	60,0	1 1/2 NPT	17,0
8254700 940x	109	201,5	167,0	160	74,0	G 2	24,0
8264700 940x	109	201,5	167,0	160	74,0	2 NPT	17,5

2/2 & 3/2 Solenoid operated valves

Buschjost 82530 / 82630 Series

Solenoid actuated diaphragm valves with forced lifting

10 mm orifice (ND)

2/2, NC, G 1/4 to G 1/2, 1/4 NPT to 1/2 NPT

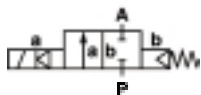

Suitable for vacuum

Clear design

Compact solenoid with integrated core tube

Valve operates without pressure differential (Δp)

Operating pressure 0 to 20 bar with a.c. and NBR seal

Technical data

Medium:

Neutral gases and liquid fluids

Viscosity:

25 mm²/s (cSt) max.

Flow direction:

Fixed

Mounting:

Optional, but preferably with solenoid facing vertically upwards

Fluid temperature:

-10°C to +90°C max.

Ambient temperature:

-10°C to +50°C max.

Consult our Technical Service for use below +2°C

Materials

Body: brass, PA 66

Seat seal: NBR (Perbunan)

Internal parts: stainless steel

1.4104/430F, 1.4303, PVDF

For contaminated fluids installation of an upstream filter is recommended.

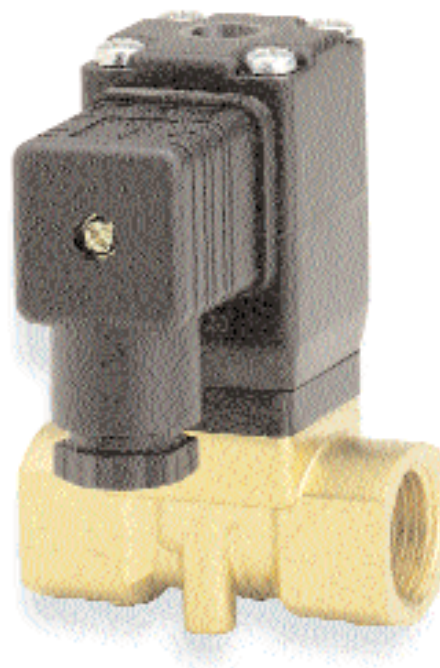

Orifice (mm)	Port size	Operating pressure (bar)	kv value m ³ /h*	Total weight (kg)	Model
10	G 1/4	0 ... 10	1,50	0,50	8253000xxxx*****
10	G 3/8	0 ... 10	1,70	0,50	8253100xxxx*****
10	G 1/2	0 ... 10	1,70	0,60	8253200xxxx*****
10	1/4 NPT	0 ... 10	1,50	0,50	8263000xxxx*****
10	3/8 NPT	0 ... 10	1,70	0,50	8263100xxxx*****
10	1/2 NPT	0 ... 10	1,70	0,60	8263200xxxx*****

xxxx Insert solenoid codes from table below. ***** Insert voltage codes from table below

* Cv (US) ≈ kv x 1,2

Options selector

825XX ★ ★ ★ ★ ★ ★ ★ ★

Alternative versions	Substitute
Seat seal material FPM, preferably for fuels and oils, max. fluid temperature +110°C	03
Seat seal material EPDM, for hot water, max. fluid temperature +110°C	14
Seat seal material HNBR, for hot water and steam, operating pressure 0 to 6 bar, fluid temperature 0°C to max. +150°C	51

Solenoid	Substitute
d.c./a.c.	8001
EEx me II T3	8041

Voltage	Substitute
24 V d.c.	02400
24 V a.c. 50 Hz	02450
110 V a.c. 50 Hz	11050
230 V a.c. 50 Hz	23050

Other voltages on request



Buschjost 82530 / 82630 Series

Solenoid actuated diaphragm valves with forced lifting

10 mm orifice (ND)

2/2, NC, G $\frac{1}{4}$ to G $\frac{1}{2}$, $\frac{1}{4}$ NPT to $\frac{1}{2}$ NPT

Electrical details for solenoid operators

	Power consumption		Voltage		Category	Protection class	Temperatures °C		Electrical connection	kg	Solenoid drawing no.#	Circuit diagram#		Model
	24 V d.c. (W)	230 V a.c. (VA)	24 V d.c. (mA)	230 V a.c. (mA)			Fluid*	Ambient**				d.c.	a.c.	
	12/12	20/16	500	70	-	IP 65	+110 max..	-25 ... +50	DIN EN 175301-803	0,22	16	1	1	8001
	12	13 VA/12 W	500	59	II 2 GD	EEx me II T3, IP65	+80 max.	-20 ... +40	Connector body	0,30	23	2	6	8041

* The maximum temperature depends on the valve type

** The maximum temperature may be higher, depending on the application.

According to VDE 0580, 100% rated

Power consumption calculated with coil at +20°C, for d.c. coils at operating temperature, power consumption is up to 30% lower

Cable clamping range 5 to 10 mm

For solenoid dimensional drawings and circuit diagrams, see page 97

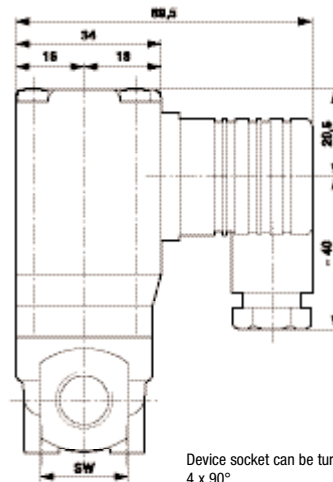
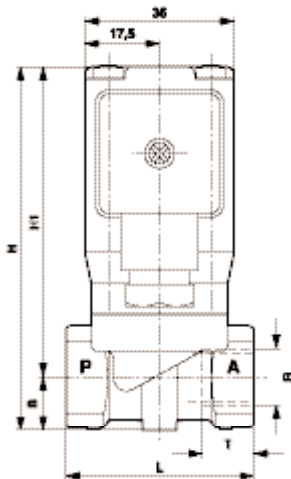

Device socket can be turned through 4 x 90°

Model	L	H	H1	B	SW	R	T
8253000xxxx*****	44	85,5	73	12,5	21	G 1/4	12
8263000xxxx*****	44	85,5	73	12,5	21	1/4 NPT	10
8253100xxxx*****	44	85,5	73	12,5	21	G 3/8	12
8263100xxxx*****	44	85,5	73	12,5	21	3/8 NPT	10
8253200xxxx*****	60	88,5	74,5	14	27	G 1/2	15
8263200xxxx*****	60	88,5	74,5	14	27	1/2 NPT	13

Buschjost 85040 / 85050 Series

Solenoid actuated angle seat valves with forced lifting

10 to 25 mm orifice (ND)

2/2, NC, G $\frac{3}{8}$ to G1 / $\frac{1}{2}$ NPT to 1 NPT

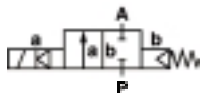

Flat piston valve

Valve operates without pressure differential (Δp)

High flow rate

Damped operation

Suitable for vacuum

Technical data

Medium:

Semi-aggressive gases and liquids

Viscosity:

40 mm²/s (cSt) max.

Flow direction:

Fixed

Mounting:

Optional, but preferably with solenoid facing vertically upwards

Fluid temperature:

-20°C to +90°C max.

Ambient temperature:

-20°C to +50°C max.

Consult our Technical Service for use below +2°C

Materials

Body: stainless steel

Seat seal: NBR (flexible when cold)

Internal parts: stainless steel,

Sandvik 1802

For contaminated fluids installation of an upstream filter is recommended.



Orifice (mm)	Port size	Operating pressure (bar)	kv value m ³ /h*	Total weight (kg)	Model
10	G 3/8	0 ... 25	3,4	1,50	8504100xxx*****
12	G 1/2	0 ... 25	3,8	1,45	8504200xxx*****
20	G 3/4	0 ... 25	11,0	3,65	8504300xxx*****
25	G 1	0 ... 25	13,0	3,50	8504400xxx*****
10	3/8 NPT	0 ... 25	3,4	1,50	8505100xxx*****
12	1/2 NPT	0 ... 25	3,8	1,45	8505200xxx*****
20	3/4 NPT	0 ... 25	11,0	3,65	8505300xxx*****
25	1 NPT	0 ... 25	13,0	3,50	8505400xxx*****

xxxx Insert solenoid codes from table below. ***** Insert voltage codes from table below

* Cv (US) \approx kv x 1,2

Options selector

850XX ★★ ★★★★★

Alternative versions	Substitute
Normally open, mounting position: Solenoid vertically upwards**	01
Seat and soft seal material FPM, max. fluid temperature +110°C*	03
Seat and soft seal material PTFE, max. fluid temperature +110°C, max. operating pressure 16 bar*	06
Seat and soft seal material EPDM, max. fluid temperature +110°C	14
Max. operating pressure 40 bar**	22
Position indicator with 2 magnetic switches **	23

* Up to +200°C fluid temperature with high-temperature solenoid

** G 3/8 (3/8 NPT) and G 1/2 (1/2 NPT) with solenoid 8401/8404

Voltage	Substitute
24 V d.c.	02400
24 V a.c. 40 to 60 Hz	02449
110 V a.c. 40 to 60 Hz	11049
230 V a.c. 40 to 60 Hz	23049

a.c. version with built-in rectifier

Solenoid	Substitute
d.c. (G3/8 to G1/2, 3/8 to 1/2 NPT)	8301
a.c. (G3/8 to G1/2, 3/8 to 1/2 NPT)	8304
d.c. (G3/4 to G1, 3/4 to 1 NPT)	8401
a.c. (G3/4 to G1, 3/4 to 1 NPT)	8404
EEx me II T3 (G3/8 to G1/2, 3/8 to 1/2 NPT)	8341
EEx me II T3 (G3/4 to G1, 3/4 to 1 NPT)	8441
EEx de IIC T4/T5 (G3/4 to G1, 3/4 to 1 NPT)	8900
EEx d IIC T4/T5 (G3/4 to G1, 3/4 to 1 NPT)	8920

Buschjost 85040 / 85050 Series

Solenoid actuated angle seat valves with forced lifting

10 to 25 mm orifice (ND)

2/2, NC, G $\frac{3}{8}$ to G1 / $\frac{3}{8}$ NPT to 1 NPT

Electrical details for solenoid operators

	Power consumption		Voltage		Category	Protection class	Temperatures °C		Electrical connection	kg	Solenoid drawing no.#	Circuit diagram#		Model
	24 V d.c. (W)	230 V a.c. (VA)	24 V d.c. (mA)	230 V a.c. (mA)			Fluid*	Ambient**				d.c.	a.c.	
	22	–	917	–	–	IP 65	+110 max.	-25 ... +50	DIN EN 175301-803	0,70	30	1	–	8301
	–	25 VA/22 W	–	107	–	IP 65	+110 max.	-25 ... +50	DIN EN 175301-803	0,70	30	–	6	8304
	40	–	1667	–	–	IP 65	+110 max.	-25 ... +50	DIN EN 175301-803	1,70	18	1	–	8401
	–	45 VA/40 W	–	195	–	IP 65	+110 max.	-25 ... +50	DIN EN 175301-803	1,70	18	–	6	8404
	22	25 VA/22 W	917	107	II 2 GD	EEx me II T3, IP65	+80 max.	-20 ... +40	Connector body	0,85	28	2	6	8341
	40	45 VA/40 W	1667	195	II 2 GD	EEx me II T3, IP65	+80 max.	-20 ... +40	Connector body	1,80	19	2	6	8441
	29	33 VA/29 W	1208	141	II 2 GD	EEx de IIC T4/T5, IP65	+110 max.	-40 ... +60/40	Cable fitting	6,30	29	2	6	8900
	29	33 VA/29 W	1208	141	II 2 GD	EEx d IIC T4/T5, IP65	+100 max.	-40 ... +75/40	Cable fitting	6,30	29	2	6	8920

* The maximum temperature depends on the valve type

** The maximum temperature may be higher, depending on the application.

According to VDE 0580, 100% rated

Power consumption calculated with coil at +20°C, for d.c. coils at operating temperature, power consumption is up to 30% lower

Cable clamping range 5 to 10 mm

Note: Restricted temperature range with explosion-proof solenoids

For solenoid dimensional drawings and circuit diagrams, see page 97 & 98

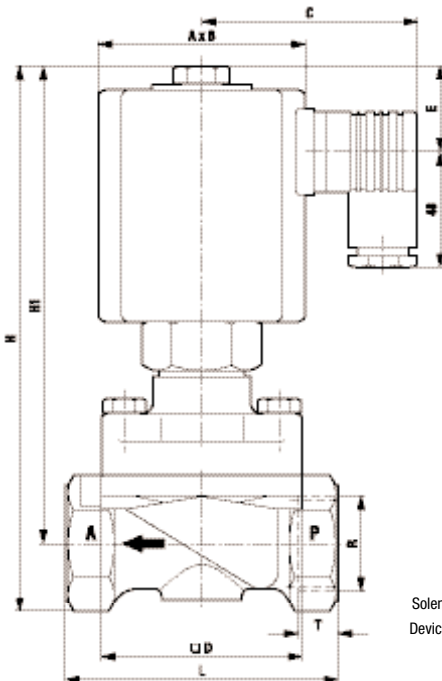

Solenoid rotates 360°
Device socket can be turned through 4 x 90°

Model	A x B	C	□ C	E	H	H1	L	R	T
8504100 830x	52 x 65	65	45	26	165	150	67	G 3/8	12
8505100 830x	52 x 65	65	45	26	165	150	67	3/8 NPT	10,5
8504200 830x	52 x 65	65	45	26	165	150	67	G 1/2	12
8505200 830x	52 x 65	65	45	26	165	150	67	1/2 NPT	13
8504300 840x	72 x 92	75	70	31	196	172	95	G 3/4	12,5
8505300 840x	72 x 92	75	70	31	196	172	95	3/4 NPT	14
8504400 840x	72 x 92	75	70	31	196	172	95	G 1	14
8505400 840x	72 x 92	75	70	31	196	172	95	1 NPT	17

2/2 & 3/2 Solenoid operated valves

Buschjost 85140 / 84140 Series

Solenoid actuated angle seat valves with forced lifting

15 to 100 mm orifice (ND)

2/2, NC, flange connection PN 16

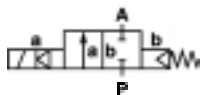

Valve operates without pressure differential (Δp)

High flow rate

Damped operation

Technical data

Medium:

Semi-aggressive gases and liquids

Viscosity:

40 mm²/s (cSt) max.

Flow direction:

Fixed

Mounting:

Optional, but preferably with solenoid facing vertically upwards; from ND 65 mm, only with solenoid facing vertically upwards

Fluid temperature:

-20°C to +110°C (15 to 50 mm orifice)

-10°C to +110°C (65 to 100 mm orifice)

Ambient temperature:

+50°C max.

Consult our Technical Service for use below +2°C

Sum of fluid and ambient temperatures:

+130°C max.

Materials

Body: stainless steel 1.4581/316Ti

Seat seal: PTFE (Teflon)

Internal parts: 1.4571/316T, 1.4301, 1.4310; Sandvik 1802 up to 50 mm; 1.4104/430F and 1.4105 from 65 mm

For contaminated fluids installation of an upstream filter is recommended.



Orifice (mm)	Port size	Operating pressure (bar)	kv value m ³ /h*	Total weight (kg)	Model
15	PN 16	0 ... 16	5,5	5,5	8514200xxxx*****
20	PN 16	0 ... 16	10,0	5,8	8514300xxxx*****
25	PN 16	0 ... 16	12,5	6,2	8514400xxxx*****
32	PN 16	0 ... 16	27,0	11,0	8514500xxxx*****
40	PN 16	0 ... 16	31,0	11,8	8514600xxxx*****
50	PN 16	0 ... 16	43,0	14,0	8514700xxxx*****
65	PN 16	0 ... 16	67,0	36,5	8414800xxxx*****
80	PN 16	0 ... 16	94,0	46,5	8414900xxxx*****
100	PN 16	0 ... 16	144,0	70,0	8415000xxxx*****

xxxx Insert solenoid codes from table below. ***** Insert voltage codes from table below

* Cv (US) ≈ kv x 1,2

Options selector

851XX ** * * * * *

Alternative versions	Substitute
Normally open, installation position: solenoid vertically upwards*	01
Position indicator with 2 magnetic switches*	23

* ND 15 mm with solenoid 8401/8404

Voltage	Substitute
24 V d.c.	02400
24 V 40 to 60 Hz	02449
110 V 40 to 60 Hz	11049
230 V 40 to 60 Hz	23049

a.c. version with built-in rectifier

Solenoid	Substitute
d.c. (ND 15)	8301
a.c. (ND 15)	8304
d.c. (ND 20 to 50)	8401
a.c. (ND 20 to 50)	8404
EEx me II T3 (ND 15)	8341
EEx me II T3 (ND 20 to 50)	8441
d.c. (ND 65 to 100)	9501
a.c. (ND 65 to 100)	9504
EEx me II T3/T4 (ND 65 to 100)	9540

Buschjost 85140 / 84140 Series

Solenoid actuated angle seat valves with forced lifting

15 to 100 mm orifice (ND)

2/2, NC, flange connection PN 16

Electrical details for solenoid operators

Image	Power consumption		Voltage		Category	Protection class	Temperatures °C		Electrical connection	kg	Solenoid drawing no.#	Circuit diagram#		Model
	24 V d.c. (W)	230 V a.c. (VA)	24 V d.c. (mA)	230 V a.c. (mA)			Fluid*	Ambient**				d.c.	a.c.	
	22	-	917	-	-	IP 65	+110 max.	-25 ... +50	DIN EN 175301-803	0,70	30	1	-	8301
	-	25 VA/22 W	-	107	-	IP 65	+110 max.	-25 ... +50	DIN EN 175301-803	0,70	30	-	6	8304
	40	-	1667	-	-	IP 65	+110 max.	-25 ... +50	DIN EN 175301-803	1,70	18	1	-	8401
	-	45 VA/40 W	-	195	-	IP 65	+110 max.	-25 ... +50	DIN EN 175301-803	1,70	18	-	6	8404
	22	25 VA/22 W	917	107	II 2 GD	EEx me II T3, IP65	+80 max.	-20 ... +40	Connector body	0,85	28	2	6	8341
	40	45 VA/40 W	1667	195	II 2 GD	EEx me II T3, IP65	+80 max.	-20 ... +40	Connector body	1,80	19	2	6	8441
	80	-	3333	-	-	IP 65	+110 max.	-25 ... +50	DIN EN 175301-803	5,85	20	1	-	9501
	-	89 VA/80 W	-	390	-	IP 65	+110 max.	-25 ... +50	DIN EN 175301-803	5,85	20	-	6	9504
	65	72 VA/65 W	2708	317	II 2 GD	EEx me II T3/T4, IP65	+70/100 max	-20 ... +40	Cable fitting	7,30	21	2	6	9540

* The maximum temperature depends on the valve type

** The maximum temperature may be higher, depending on the application.

According to VDE 0580, 100% rated

Power consumption calculated with coil at +20°C, for d.c. coils at operating temperature, power consumption is up to 30% lower

Cable clamping range 5 to 10 mm

Note: Restricted temperature range with explosion-proof solenoids

For solenoid dimensional drawings and circuit diagrams, see page 97 & 98

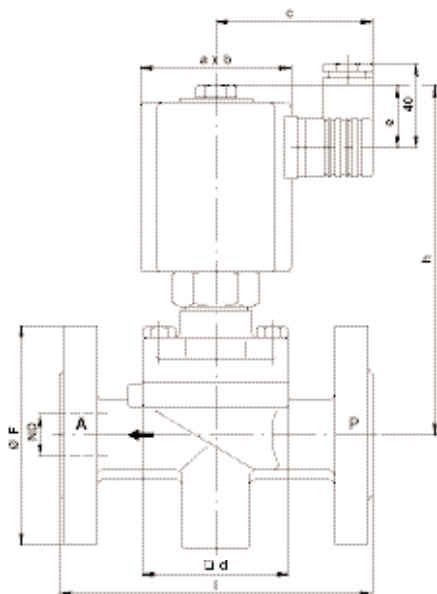

Solenoid rotates 360°
Device socket can be turned through 4 x 90°

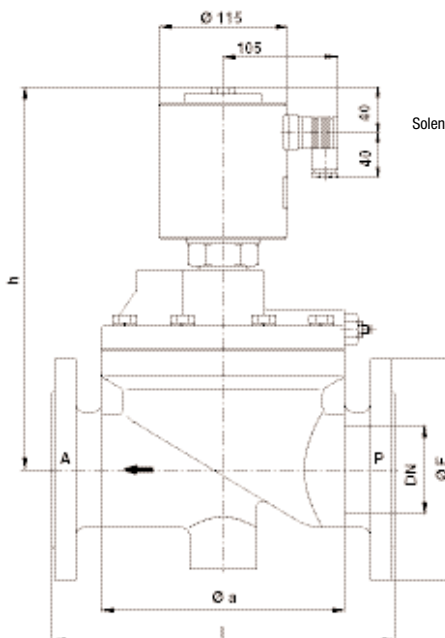

Solenoid rotates 360°

Flange connection PN 16 according to DIN 2543/2545
Sealing strip DIN 2526 Pattern C

Model	A x B	C	□ D	E	H	I	DN	Ø F
8514200xxxx	52 x 65	65	70	26	145	130	15	95
8514300xxxx	72 x 92	75	70	31	172	150	20	105
8514400xxxx	72 x 92	75	70	31	172	160	25	115
8514500xxxx	72 x 92	75	96	31	187	180	32	140
8514600xxxx	72 x 92	75	96	31	191	200	40	150
8514700xxxx	72 x 92	75	112	31	200	230	50	165

Flange connection PN 16 according to DIN 2543
Sealing strip DIN 2526 Pattern C

Model	Ø A	H	I	DN	Ø F
8414800xxxx	195	330	290	65	185
8414900xxxx	220	350	310	80	200
8415000xxxx	260	378	350	100	220

2/2 & 3/2 Solenoid operated valves

Buschjost 82560 / 82570 Series

Solenoid actuated diaphragm valves with forced lifting

10 mm orifice (ND)

2/2, NC, G 1/4 to G 1/2 / 1/4 NPT to 1/2 NPT

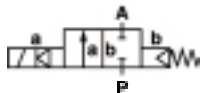

Suitable for vacuum

Clear design

Compact solenoid with integrated core tube

Valve operates without pressure differential (Δp)

Technical data

Medium:

Semi-aggressive gases and liquids

Viscosity:

25 mm²/s (cSt)

Flow direction:

Fixed

Mounting:

Optional, but preferably with solenoid facing vertically upwards

Fluid temperature:

-10°C to +90°C max.

Ambient temperature:

-10°C to +50°C max.

Consult our Technical Service for use below +2°C

Materials

Body: stainless steel, PA 66

Seat seal: NBR (Perbunan)

Internal parts: stainless steel, PVDF, Sandvik 1802

For contaminated fluids installation of an upstream filter is recommended.



Orifice (mm)	Port size	Operating pressure (bar)	kv value m ³ /h*	Total weight (kg)	Model
10	G 1/4	0 ... 10	1,5	0,5	8256000xxxx*****
10	G 3/8	0 ... 10	1,7	0,5	8256100xxxx*****
10	G 1/2	0 ... 10	1,7	0,6	8256200xxxx*****
10	1/4 NPT	0 ... 10	1,5	0,5	8257000xxxx*****
10	3/8 NPT	0 ... 10	1,7	0,5	8257100xxxx*****
10	1/2 NPT	0 ... 10	1,7	0,6	8257200xxxx*****

xxxx Insert solenoid codes from table below. ***** Insert voltage codes from table below

* Cv (US) = kv x 1,2

Options selector

825XX ** ★★★★★

Alternative versions	Substitute
Seat seal material FPM, preferably for fuels and oils max. fluid temperature +110°C	01
Seat seal material EPDM, for hot water, max. fluid temperature +110°C	14
Solenoid	Substitute
d.c.	9748
a.c.	9749

Voltage	Substitute
24 V d.c.	02400
24 V a.c. 40 to 60 Hz	02449
110 V a.c. 40 to 60 Hz	11049
230 V a.c. 40 to 60 Hz	23049

a.c. version with built-in rectifier

Buschjost 82560 / 82570 Series

Solenoid actuated diaphragm valves with forced lifting

10 mm orifice (ND)

2/2, NC, G $\frac{1}{4}$ to G $\frac{1}{2}$ / $\frac{1}{4}$ NPT to $\frac{1}{2}$ NPT

Electrical details for solenoid operators

	Power consumption		Voltage		Category	Protection class	Temperatures °C		Electrical connection	kg	Solenoid drawing no.#	Circuit diagram#		Model
	24 V d.c. (W)	230 V a.c. (VA)	24 V d.c. (mA)	230 V a.c. (mA)			Fluid*	Ambient**				d.c.	a.c.	
	12	–	500	–	–	IP 65	+110 max.	-25 ... +50	DIN EN 175301-803	0,22	16	1	–	9748
	–	13 VA/12 W	–	59	–	IP 65	+110 max.	-25 ... +50	DIN EN 175301-803	0,22	16	–	6	9749

* The maximum temperature depends on the valve type

** The maximum temperature may be higher, depending on the application.

According to VDE 0580, 100% rated

Power consumption calculated with coil at +20°C, for d.c. coils at operating temperature, power consumption is up to 30% lower

For solenoid dimensional drawings and circuit diagrams, see page 97

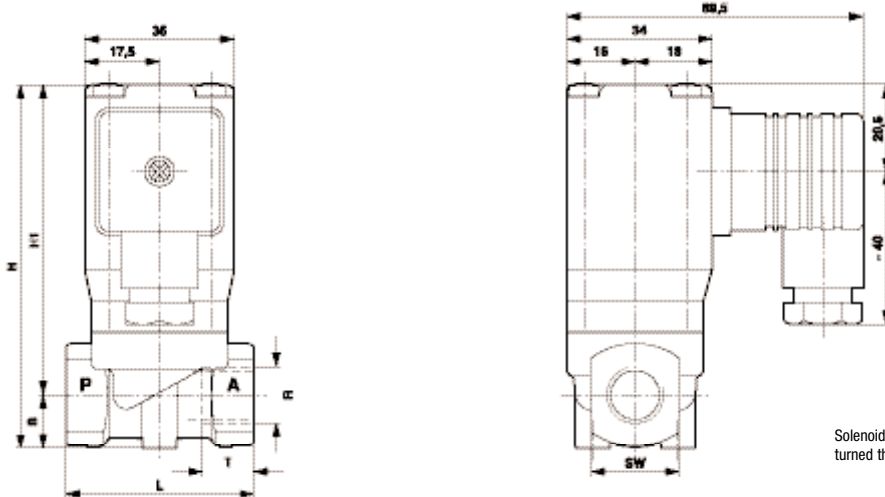

Solenoid and device socket can be turned through 4 x 90°

Model	L	H	H1	B	SW	R	T
8256000 974X	44	85,5	73,0	12,5	21	G 1/4	12,0
8257000 974X	44	85,5	73,0	12,5	21	1/4 NPT	10,0
8256100 974X	44	85,5	73,0	12,5	21	G 3/8	12,0
8257100 974X	44	85,5	73,0	12,5	21	3/8 NPT	10,0
8256200 974X	60	88,5	74,5	14,0	27	G 1/2	15,0
8257200 974X	60	88,5	74,5	14,0	27	1/2 NPT	13,0

2/2 & 3/2 Solenoid operated valves

Buschjost 82360 / 82460 Series

Solenoid actuated diaphragm valves with forced lifting

8 to 25 mm orifice (ND)

2/2, NC, G¼ to G1 / ¼ NPT to 1 NPT

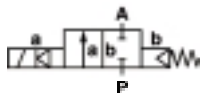

Valve operates without pressure differential (Δp)

High flow rate

Easily interchangeable solenoid

Technical data

Medium:

Neutral gases and liquid fluids

Viscosity:

25 mm²/s (cSt) max.

Flow direction:

Fixed

Mounting:

Optional, but preferably with solenoid facing vertically upwards

Fluid temperature:

-10°C to +150°C max.

Ambient temperature:

-10°C to +60°C max.

Consult our Technical Service for use below +2°C

Materials

Body: brass

Seat seal: HNBR

Internal parts: stainless steel, brass,

PVDF

For contaminated fluids installation of an upstream filter is recommended.



Orifice (mm)	Port size	Operating pressure (bar)	kv value m ³ /h*	Total weight (kg)	Model
8	G 1/4	0 ... 10	1,90	1,3	823600xxxx*****
10	G 3/8	0 ... 10	2,60	1,2	823610xxxx*****
12	G 1/2	0 ... 10	3,20	1,2	823620xxxx*****
20	G 3/4	0 ... 10	7,00	1,9	823630xxxx*****
25	G 1	0 ... 10	8,00	1,8	823640xxxx*****
8	1/4 NPT	0 ... 10	1,90	1,3	824600xxxx*****
10	3/8 NPT	0 ... 10	2,60	1,2	824610xxxx*****
12	1/2 NPT	0 ... 10	3,20	1,2	824620xxxx*****
20	3/4 NPT	0 ... 10	7,00	1,9	824630xxxx*****
25	1 NPT	0 ... 10	8,00	1,8	824640xxxx*****

xxxx Insert solenoid codes from table below. ***** Insert voltage codes from table below

* Cv (US) ≈ kv x 1,2

Options selector

8236X ** * * * * *

Alternative versions	Solenoid	Substitute	Voltage	Substitute
On request	d.c.	8302	24 V d.c.	02400
	a.c.	8306	110 V d.c.	11000
			24 V a.c. 40 to 60 Hz	02449
			110 V a.c. 40 to 60 Hz	11049
			230 V a.c. 40 to 60 Hz	23049

a.c. version with built-in rectifier

Buschjost 82360 / 82460 Series

Solenoid actuated diaphragm valves with forced lifting

8 to 25 mm orifice (ND)

2/2, NC, G $\frac{1}{4}$ to G1 / $\frac{1}{4}$ NPT to 1 NPT

Electrical details for solenoid operators

	Power consumption		Voltage		Category	Protection class	Temperatures °C		Electrical connection	kg	Solenoid drawing no.#	Circuit diagram#		Model
	24 V d.c. (W)	230 V a.c. (VA)	24 V d.c. (mA)	230 V a.c. (mA)			Fluid*	Ambient**				d.c.	a.c.	
	14	—	583	—	—	IP 65	+200 max.	-25 ... +60	DIN EN 175301-803	0,70	30	1	—	8302
	—	16 VA/14 W	—	68	—	IP 65	+200 max.	-25 ... +60	DIN EN 175301-803	0,70	30	—	6	8306

* The maximum temperature depends on the valve type

** The maximum temperature may be higher, depending on the application.

According to VDE 0580, 100% rated

Power consumption calculated with coil at +20°C, for d.c. coils at operating temperature, power consumption is up to 30% lower

For solenoid dimensional drawings and circuit diagrams, see page 98

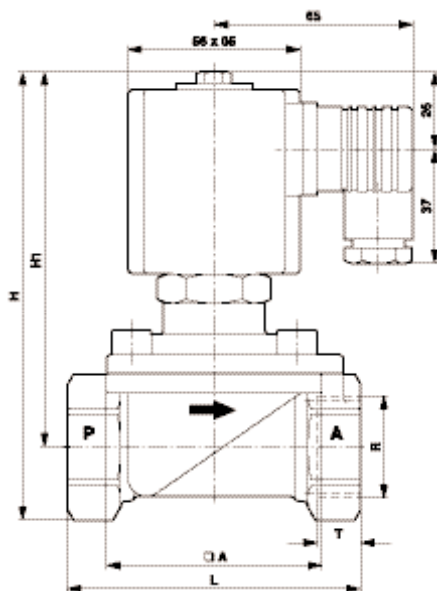

Solenoid rotates 360°
Device socket can be turned through 4 x 90°

Model	□ A	H	H1	L	R	T
8236000 830X	44	125	110	67	G 1/4	12,0
8246000 830X	44	125	110	67	1/4 NPT	10,0
8236100 830X	44	125	110	67	G 3/8	12,0
8246100 830X	44	125	110	67	3/8 NPT	10,5
8236200 830X	44	125	110	67	G 1/2	14,0
8246200 830X	44	125	110	67	1/2 NPT	13,5
8236300 830X	70	150	125	95	G 3/4	12,5
8246300 830X	70	150	125	95	3/4 NPT	14,0
8236400 830X	70	150	125	95	G 1	14,0
8246400 830X	70	150	125	95	1 NPT	17,0

2/2 & 3/2 Solenoid operated valves

Buschjost 85700 / 85710 Series

Solenoid actuated, with forced lifting

8 to 50 mm orifice (ND)

2/2, NC, G¼ to G½ / ¼ NPT to 2 NPT

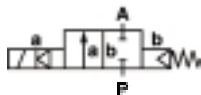

High flow rate

For robust industry solutions

Damped operation

Suitable for vacuum

For systems with low or discontinuous pressure

Valve operates without pressure differential

Stainless steel piston

Solenoid interchangeable without tools (Click-on®) to G1

Technical data

Medium:

Neutral gases and liquid fluids

Viscosity:

With gases and liquids up to 40 mm²/s (cSt)

Flow direction:

Fixed

Mounting:

Optional, but preferably with solenoid facing vertically upwards

Fluid temperature:

-10°C to max. +90°C

Ambient temperature:

-10°C to max. +50°C

Consult our Technical Service for use below +2°C

Materials

Body: brass

Seat seal: NBR (Perbunan)

Internal parts: stainless steels, PTFE/carbon

For contaminated fluids installation of an upstream filter is recommended.



Orifice (mm)	Port size	Operating pressure (bar)	kv value m ³ /h*	Total weight (kg)	Model
8	G 1/4	0 ... 25	2,2	2,40	857000xxxx*****
10	G 3/8	0 ... 25	3,4	2,40	857010xxxx*****
12	G 1/2	0 ... 25	4,4	2,50	857020xxxx*****
20	G 3/4	0 ... 25	7,0	2,70	857030xxxx*****
25	G 1	0 ... 25	10,5	3,10	857040xxxx*****
32	G 1¼	0 ... 25	25,0	5,60	857050xxxx*****
40	G 1½	0 ... 25	27,0	5,40	857060xxxx*****
50	G 2	0 ... 25	43,0	6,80	857070xxxx*****
8	1/4 NPT	0 ... 25	2,2	2,40	857100xxxx*****
10	3/8 NPT	0 ... 25	3,4	2,40	857110xxxx*****
12	1/2 NPT	0 ... 25	4,4	2,50	857120xxxx*****
20	3/4 NPT	0 ... 25	7,0	2,70	857130xxxx*****
25	1 NPT	0 ... 25	10,5	3,10	857140xxxx*****
32	1¼ NPT	0 ... 25	25,0	5,60	857150xxxx*****
40	1½ NPT	0 ... 25	27,0	5,40	857160xxxx*****
50	2 NPT	0 ... 25	43,0	6,80	857170xxxx*****

xxxx Insert solenoid codes from table below. ***** Insert voltage codes from table below

* Cv (US) ≈ kv x 1,2

Options selector

857XX ★★ ★★★★★

Alternative versions	Substitute	Voltage	Substitute
Normally open, installation position: solenoid vertically upwards; only for solenoid 8400	01	24 V d.c.	02400
Manual override	02	205 V d.c.	20550
Seat seal material FPM, max. fluid temperature +110°C*	03	24 V a.c. 40 to 60 Hz	02449
Seat seal material PTFE, max. fluid temperature +110°C*, max. operating pressure 16 bar	06	110 V a.c. 40 to 60 Hz	11049
Seat seal material EPDM, max. fluid temperature +110°C	14	230 V a.c. 40 to 60 Hz	23049
Normally open, seat seal material FPM, max. fluid temperature +110°C*, installation position: Solenoid vertically upwards, only with solenoid 8400	17	a.c. version with built-in rectifier	
Max. operating pressure 40 bar	22	Solenoid	
Position indicator with 2 magnetic switches; only with solenoid 8400	23	d.c. (ND 8 to 25)	9402
Seat seal material FPM, with larger mounting holes in piston, e.g. for fuels and oils, max. viscosity 80 mm ² /s (cSt)	25	a.c. (ND 8 to 25)	9406
max. fluid temperature +110°C*	25	d.c. (ND 32 to 50)	8402
Low-temperature version; down to -20°C	28	a.c. (ND 32 to 50)	8406

EEX solenoids, categories 2 and 3, on request

* Up to +200°C fluid temperature with high-temperature solenoid

Buschjost 85700 / 85710 Series

Solenoid actuated, with forced lifting

8 to 50 mm orifice (ND)

2/2, NC, G¼ to G½ / ¼ NPT to 2 NPT

Electrical details for solenoid operators

	Power consumption		Voltage		Category	Protection class	Temperatures °C		Electrical connection	kg	Solenoid drawing no.#	Circuit diagram#		Model
	24 V d.c. (W)	230 V a.c. (VA)	24 V d.c. (mA)	230 V a.c. (mA)			Fluid*	Ambient**				d.c.	a.c.	
	38	–	1583	–	–	IP 65	+110 max.	-25 ... +50	DIN EN 175301-803	1,40	25	1	–	9401
	–	42 VA/38 W	–	185	–	IP 65	+110 max.	-25 ... +50	DIN EN 175301-803	1,40	25	–	6	9404
	40	–	1667	–	–	IP 65	+110 max.	-25 ... +50	DIN EN 175301-803	1,70	18	1	–	8401
	–	45 VA/40 W	–	195	–	IP 65	+110 max.	-25 ... +50	DIN EN 175301-803	1,70	18	–	6	8404

* The maximum temperature depends on the valve type

** The maximum temperature may be higher, depending on the application.

According to VDE 0580, 100% rated

Power consumption calculated with coil at +20°C, for d.c. coils at operating temperature, power consumption is up to 30% lower

Note: Restricted temperature range with explosion-proof solenoids

For solenoid dimensional drawings and circuit diagrams, see page 97

Up to G 1 or 1 NPT

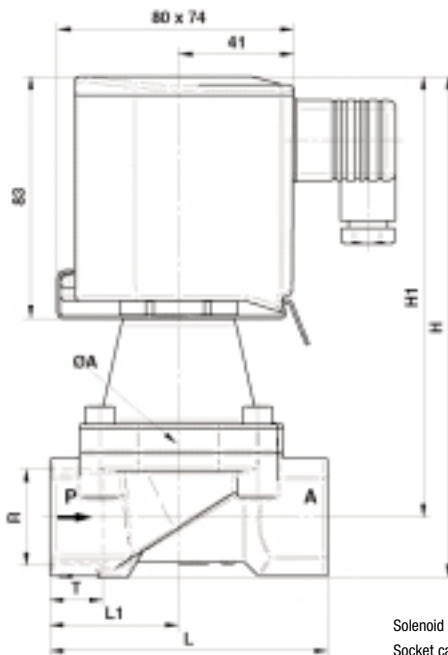

Solenoid rotates 360°
Socket can be turned through 4 x 90°

From G 1¼ or 1¼ NPT

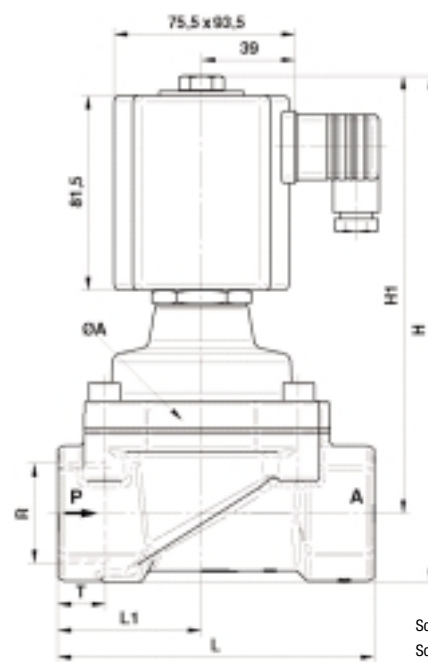

Solenoid rotates 360°
Socket can be turned through 4 x 90°

Model	Ø A	H	H1	L	L1	R	T
8570000.940x	44	152,0	140,5	60	27,5	G 1/4	12,0
8571000.940x	44	152,0	140,5	60	27,5	1/4 NPT	12,0
8570100.940x	44	152,0	140,5	60	27,5	G 3/8	12,0
8571100.940x	44	152,0	140,5	60	27,5	3/8 NPT	12,0
8570200.940x	44	154,5	140,5	67	31,0	G 1/2	14,0
8571200.940x	44	154,5	140,5	67	31,0	1/2 NPT	14,0
8570300.940x	50	162,0	146,5	80	36,5	G 3/4	16,0
8571300.940x	50	162,0	146,5	80	36,5	3/4 NPT	16,0
8570400.940x	62	183,0	162,0	95	44,0	G 1	18,0
8571400.940x	62	183,0	162,0	95	44,0	1 NPT	18,0
8570500.840x	92	212,5	183,5	132	60,0	G 1¼	20,0
8571500.840x	92	212,5	183,5	132	60,0	1¼ NPT	20,0
8570600.840x	92	212,5	183,5	132	60,0	G 1½	22,0
8571600.840x	92	212,5	183,5	132	60,0	1½ NPT	22,0
8570700.840x	109	226,5	192,0	160	74,0	G 2	24,0
8571700.840x	109	226,5	192,0	160	74,0	2 NPT	24,0

2/2 & 3/2 Solenoid operated valves

Buschjost 85720 / 85730 Series

Solenoid actuated, with forced lifting

8 to 50 mm orifice (ND)

2/2, NC, G $\frac{1}{4}$ to G $\frac{1}{2}$ / $\frac{1}{4}$ NPT to 2 NPT

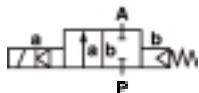

High flow rate

For robust industry solutions

Damped operation

Valve operates without pressure differential

Solenoid interchangeable without tools (Click-on[®]) to G1

Technical data

Medium:

Neutral gases and liquids

Viscosity:

With gases and liquids up to

40 mm²/s (cSt)

Flow direction:

Fixed

Mounting:

Solenoid facing vertically

downwards (up to +150°C

preferably with solenoid facing

vertically upwards)

Fluid temperature:

0°C to max. +200°C

Ambient temperature:

0°C to max. +60°C

Consult our Technical Service for use below +2°C

Materials

Body: brass

Seat seal: PTFE

Internal parts: stainless steels,

PTFE/carbon/FPM

For contaminated fluids installation of an upstream filter is recommended.



Orifice (mm)	Port size	Operating pressure (bar)**	kv value m ³ /h*	Total weight (kg)	Model
8	G 1/4	0 ... 16	1,9	2,40	8572000xxxx*****
10	G 3/8	0 ... 16	3,0	2,40	8572100xxxx*****
12	G 1/2	0 ... 16	3,8	2,50	8572200xxxx*****
20	G 3/4	0 ... 16	6,1	2,70	8572300xxxx*****
25	G 1	0 ... 16	9,5	3,10	8572400xxxx*****
32	G 1 1/4	0 ... 16	23,0	5,60	8572500xxxx*****
40	G 1 1/2	0 ... 16	25,0	5,40	8572600xxxx*****
50	G 2	0 ... 16	41,0	6,80	8572700xxxx*****
8	1/4 NPT	0 ... 16	1,9	2,40	8573000xxxx*****
10	3/8 NPT	0 ... 16	3,0	2,40	8573100xxxx*****
12	1/2 NPT	0 ... 16	3,8	2,50	8573200xxxx*****
20	3/4 NPT	0 ... 16	6,1	2,70	8573300xxxx*****
25	1 NPT	0 ... 16	9,5	3,10	8573400xxxx*****
32	1 1/4 NPT	0 ... 16	23,0	5,60	8573500xxxx*****
40	1 1/2 NPT	0 ... 16	25,0	5,40	8573600xxxx*****
50	2 NPT	0 ... 16	41,0	6,80	8573700xxxx*****

xxxx Insert solenoid codes from table below. ***** Insert voltage codes from table below

* Cv (US) ≈ kv x 1,2

Options selector

857XX ** * * * * *

Alternative versions	Substitute
On request	
Solenoid	Substitute
d.c. (ND 8 to 25)	9402
a.c. (ND 8 to 25)	9406
d.c. (ND 32 to 50)	8402
a.c. (ND 32 to 50)	8406

Voltage	Substitute
24 V d.c.	02400
205 V d.c.	20550
24 V a.c. 40 to 60 Hz	02449
110 V a.c. 40 to 60 Hz	11049
230 V a.c. 40 to 60 Hz	23049

a.c. version with built-in rectifier

Buschjost 85720 / 85730 Series

Solenoid actuated, with forced lifting

8 to 50 mm orifice (ND)

2/2, NC, G $\frac{1}{4}$ to G $\frac{1}{2}$ / $\frac{1}{4}$ NPT to 2 NPT

Electrical details for solenoid operators

	Power consumption		Voltage		Category	Protection class	Temperatures °C		Electrical connection	kg	Solenoid drawing no.#	Circuit diagram#		Model
	24 V d.c. (W)	230 V a.c. (VA)	24 V d.c. (mA)	230 V a.c. (mA)			Fluid*	Ambient**				d.c.	a.c.	
	29	—	1208	—	—	IP 65	+200 max.	-25 ... +60	DIN EN 175301-803	1,40	25	1	—	9402
	—	33 VA/29 W	—	141	—	IP 65	+200 max.	-25 ... +60	DIN EN 175301-803	1,40	25	—	6	9406
	29	—	1208	—	—	IP 65	+200 max.	-25 ... +60	DIN EN 175301-803	1,70	18	1	—	8402
	—	33 VA/29 W	—	141	—	IP 65	+200 max.	-25 ... +60	DIN EN 175301-803	1,70	18	—	6	8406

* The maximum temperature depends on the valve type

** The maximum temperature may be higher, depending on the application.

According to VDE 0580, 100% rated

Power consumption calculated with coil at +20°C, for d.c. coils at operating temperature, power consumption is up to 30% lower

Note: Restricted temperature range with explosion-proof solenoids

For solenoid dimensional drawings and circuit diagrams, see page 97

Up to G 1 or 1 NPT

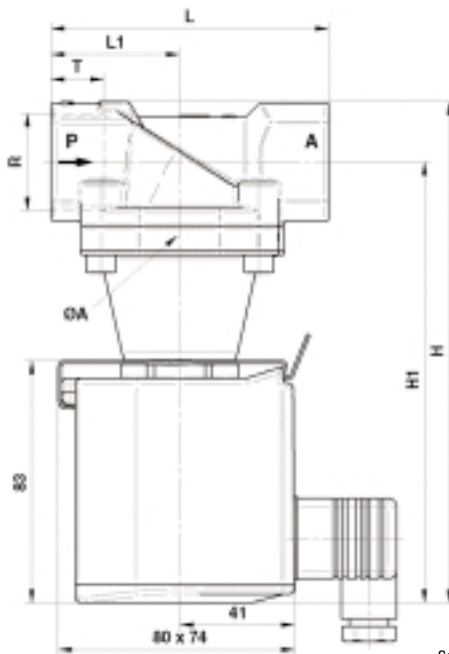

Solenoid rotates 360°
Socket can be turned through 4 x 90°

From G 1 ¼ or 1 ½ NPT

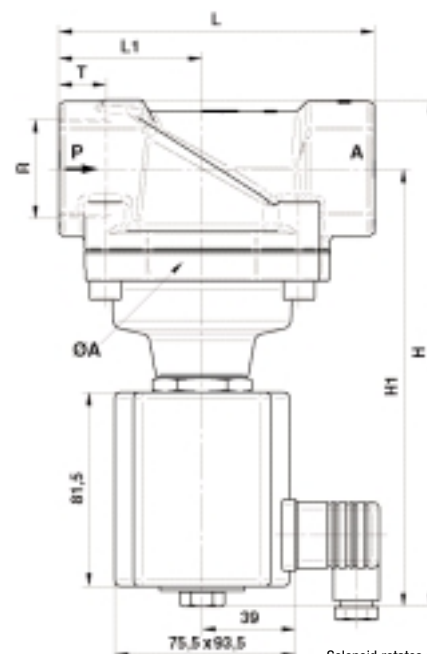

Solenoid rotates 360°
Socket can be turned through 4 x 90°

Model	Ø A	H	H1	L	L1	R	T
8572000.940x	44	152,0	140,5	60	27,5	G 1/4	12,0
8573000.940x	44	152,0	140,5	60	27,5	1/4 NPT	10,0
8572100.940x	44	152,0	140,5	60	27,5	G 3/8	12,0
8573100.940x	44	152,0	140,5	60	27,5	3/8 NPT	10,5
8572200.940x	44	154,5	140,5	67	31,0	G 1/2	14,0
8573200.940x	44	154,5	140,5	67	31,0	1/2 NPT	13,5
8572300.940x	50	162,0	146,5	80	36,5	G 3/4	16,0
8573300.940x	50	162,0	146,5	80	36,5	3/4 NPT	14,0
8572400.940x	62	183,0	162,0	95	44,0	G 1	18,0
8573400.940x	62	183,0	162,0	95	44,0	1 NPT	17,0
8572500.840x	92	212,5	183,5	132	60,0	G 1 ¼	20,0
8573500.840x	92	212,5	183,5	132	60,0	1 ¼ NPT	17,0
8572600.840x	92	212,5	183,5	132	60,0	G 1 ½	22,0
8573600.840x	92	212,5	183,5	132	60,0	1 ½ NPT	17,0
8572700.840x	109	226,5	192,0	160	74,0	G 2	24,0
8573700.840x	109	226,5	192,0	160	74,0	2 NPT	17,5

Solenoid dimensional drawings

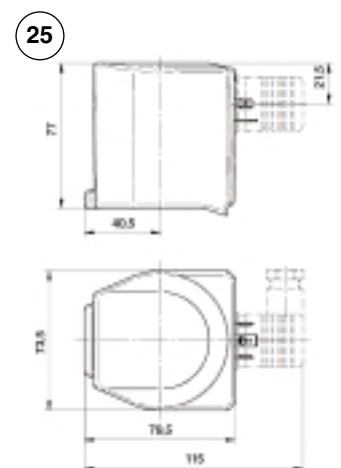
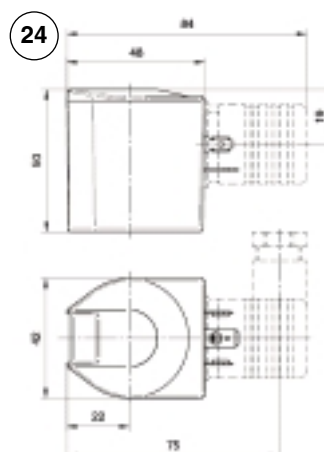
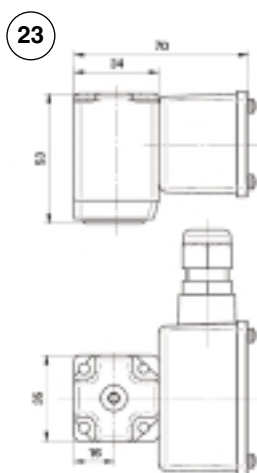
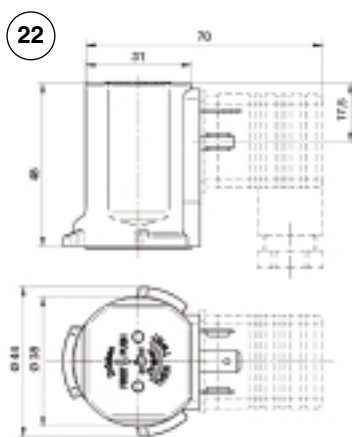
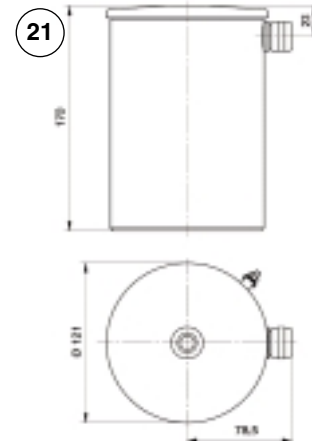
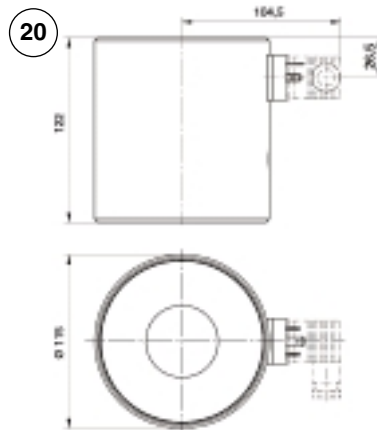
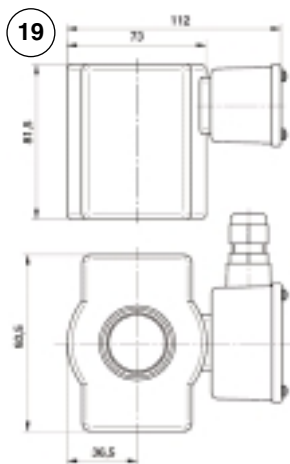
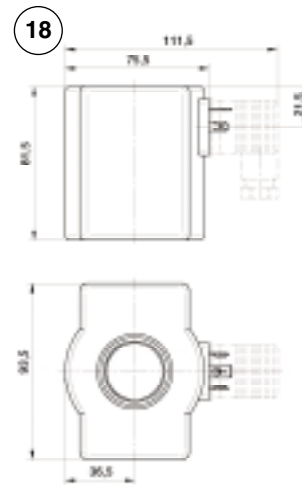
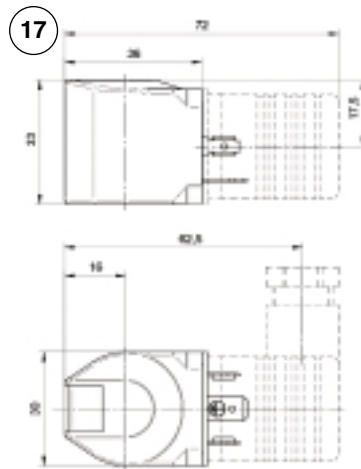
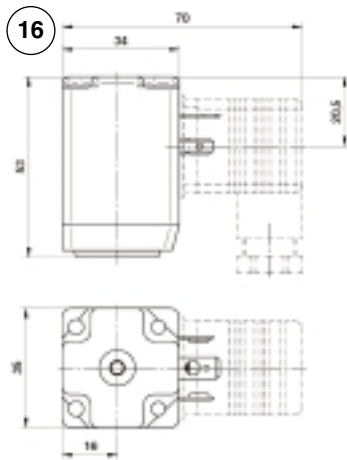

Circuit diagrams

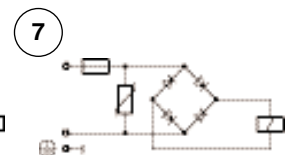
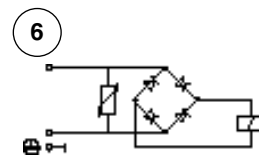
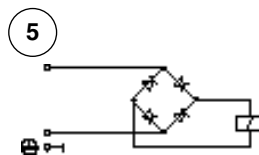
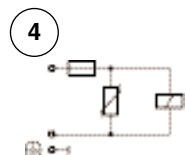
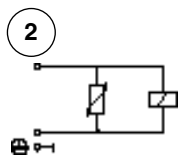
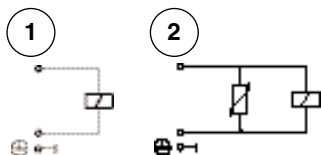

Solenoid dimensional drawings

26

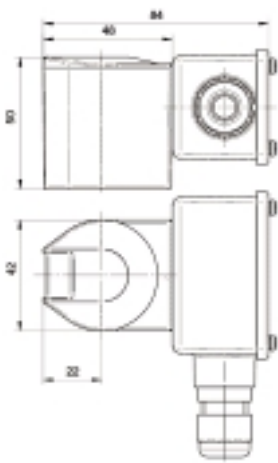

27

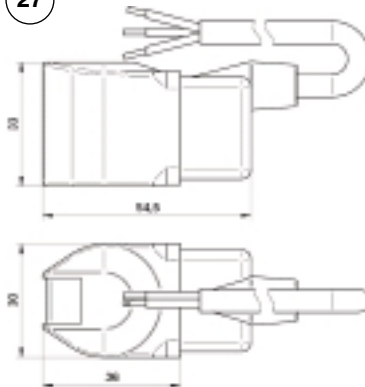

28

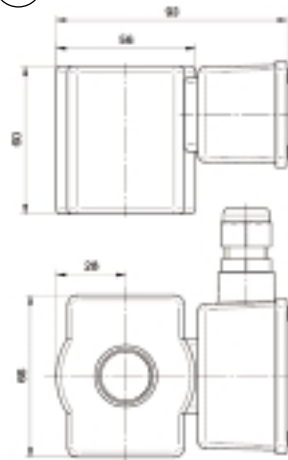

29

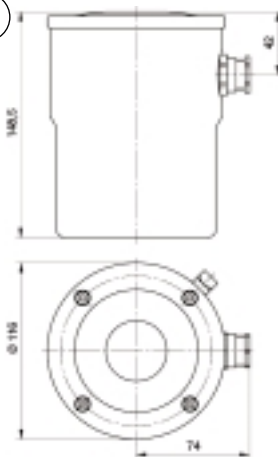

30

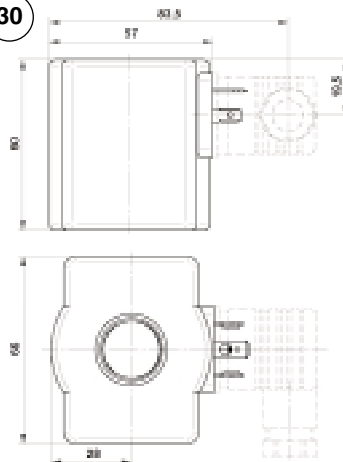

39

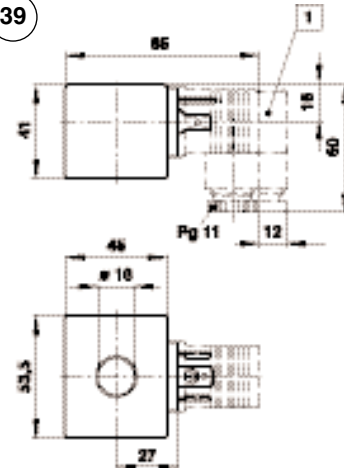

40

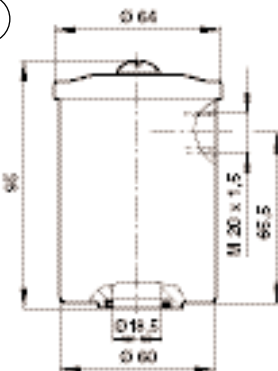

Circuit diagrams

1

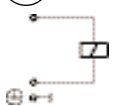

2

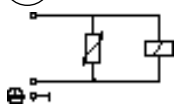

4

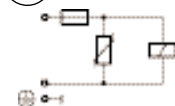

5

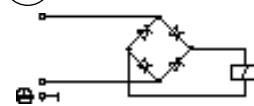

6

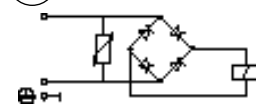

7

