

PRESA D'ARIA

porting block

Può essere utilizzata per prelevare aria non lubrificata e/o non regolata

It can be used to provide unlubricated and/or unregulated air

G1/4"

CODICE DI ORDINAZIONE
ORDER CODE

PAI 2-00



Materiale: alluminio

Material: aluminium

Ogni pezzo è venduto in kit con i particolari necessari al suo assemblaggio

Each element is sold in kit with all necessary pieces for installation

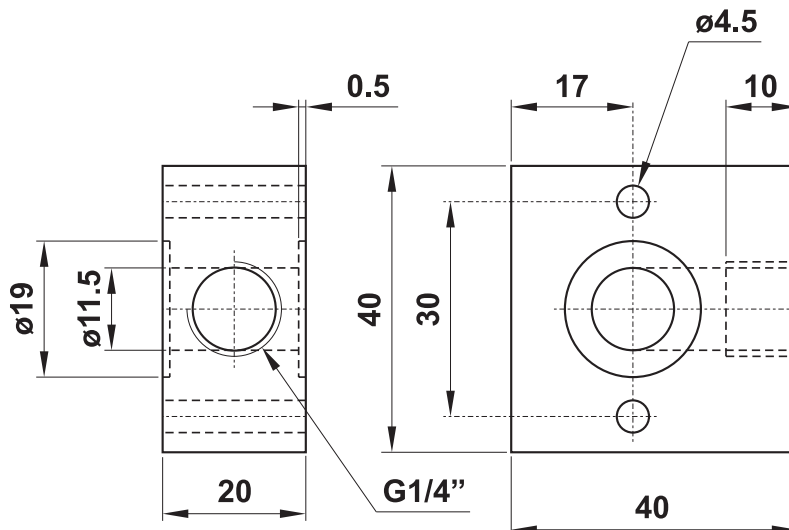

Ogni pezzo è venduto in kit con i particolari necessari al suo assemblaggio

Each element is sold in kit with all necessary pieces for installation

G3/8"

CODICE DI ORDINAZIONE
ORDER CODE

PAI 3-00



Materiale: zamak

Material: zamak

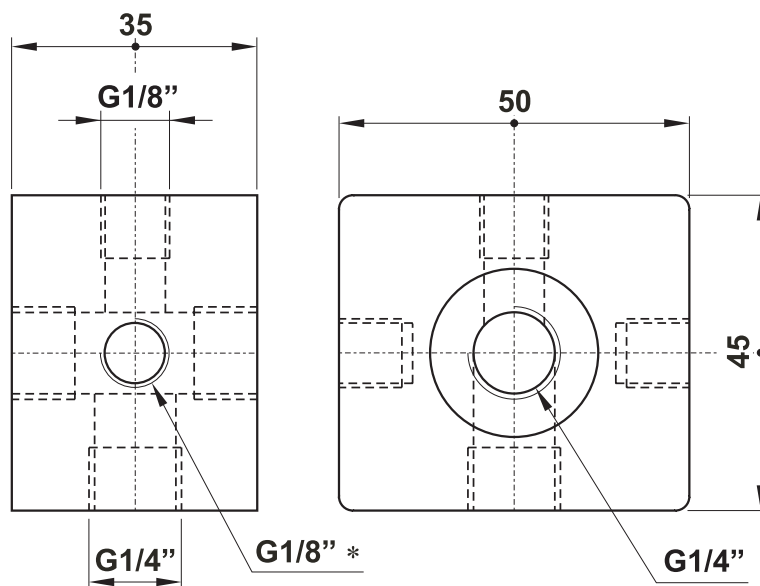

* : filetto G1/8" (prof. 10 mm circa) da ambo le parti.

In caso di necessità l'utilizzatore può forare il fondo per avere una presa d'aria aggiuntiva (foro $\varnothing 4$).

* : G1/8" thread on both sides (depth about 10 mm) ready for through-drilling hole $\varnothing 4$.

accessori per gruppi trattamento aria

accessories for air preparation units



G1/2"

CODICE DI ORDINAZIONE
ORDER CODE

PAI 4N-00

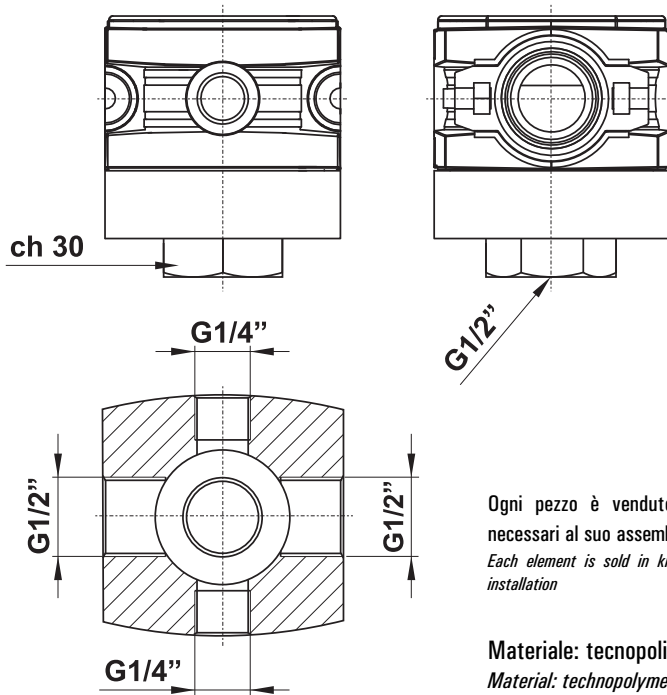

Ogni pezzo è venduto in kit con i particolari necessari al suo assemblaggio
Each element is sold in kit with all necessary pieces for installation

Materiale: tecnopolimero
Material: technopolymer

G1"

CODICE DI ORDINAZIONE
ORDER CODE

PAI 6N-00

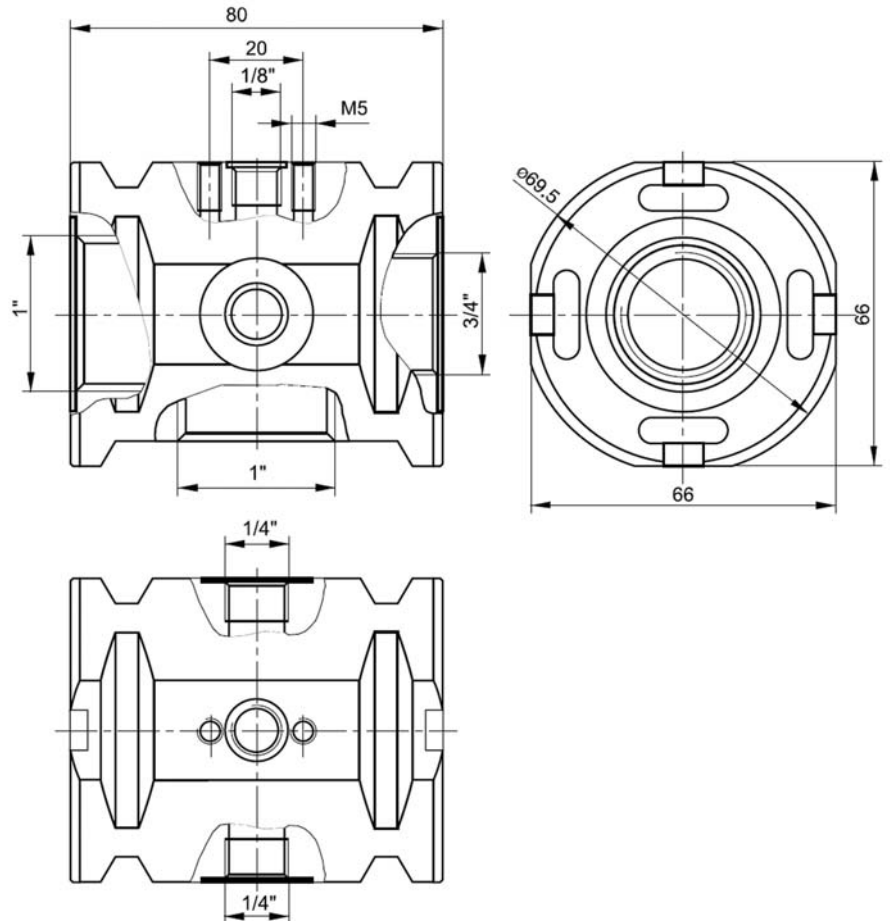

Materiale: alluminio *Material: aluminium*

Ogni pezzo è venduto in kit con i particolari necessari al suo assemblaggio

Each element is sold in kit with all necessary pieces for installation

OLIO PER GRUPPI TRATTAMENTO ARIA

oil for air preparation units

CODICE DI ORDINAZIONE
ORDER CODE

16.172.0



Olio idraulico, classe di viscosità VG32 a norma ISO 3448

Hydraulic oil, viscosity class VG32 according to norm ISO 3448

Istruzioni per l'uso:

Riempire la tazza del lubrificatore fino al livello raccomandato. Regolare, ove possibile, il flusso di olio a circa 2 gocce al minuto. Non usare a temperature inferiori a +5°C.

Instructions for use:

Fill the lubricator to the recommended level. Regulate, where possible, the oil flow at about 2 drops/minute. Do not use at temperatures below +5°C

Dati tecnici

Densità a 15°C: 0.8655 g/ml

Densità a 20°C: 0.8621 g/ml

Viscosità cinematica a 40°C: 30.1205 mm²/s

Indice di viscosità: 109

Temperatura di fiamma all'aperto: 208°C

Temperatura di fiamma al chiuso: 196°C

Temperatura di scorrimento: sotto -15°C

Technical data

Density at 15°C: 0.8655 g/ml

Density at 20°C: 0.8621 g/ml

Kinematic viscosity at 40°C: 30.1205 mm²/s

Viscosity index: 109

Flash point in open space: 208°C

Flash point in closed space: 196°C

Pour point: below -15°C

PROTEZIONE PER TAZZA

bowl protection

G1/4"

PLASTICA

CODICE DI ORDINAZIONE
ORDER CODE

PR 2-00

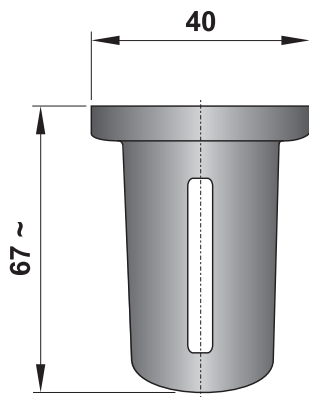

G3/8"

METALLO

CODICE DI ORDINAZIONE
ORDER CODE

PR 3-00

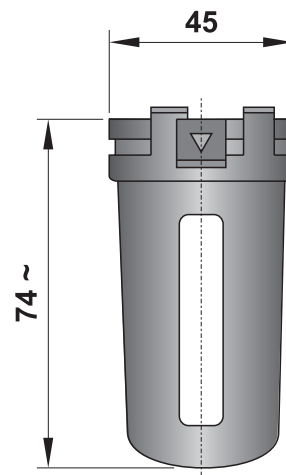

G1/2"

METALLO

CODICE DI ORDINAZIONE
ORDER CODE

PR 4-00

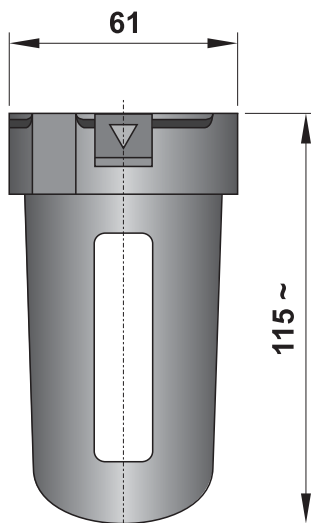

KIT MONTAGGIO

coupling kit

G1/4"

CODICE DI ORDINAZIONE
ORDER CODE

KIT 2-00

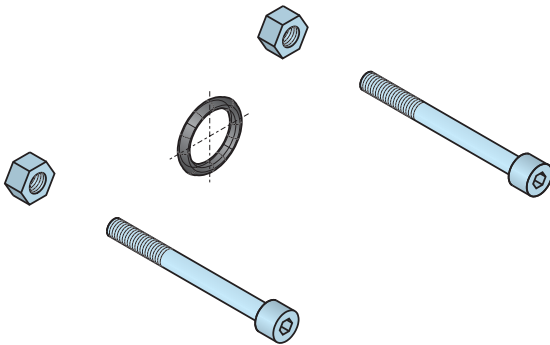

G3/8"

CODICE DI ORDINAZIONE
ORDER CODE

KIT 3-00

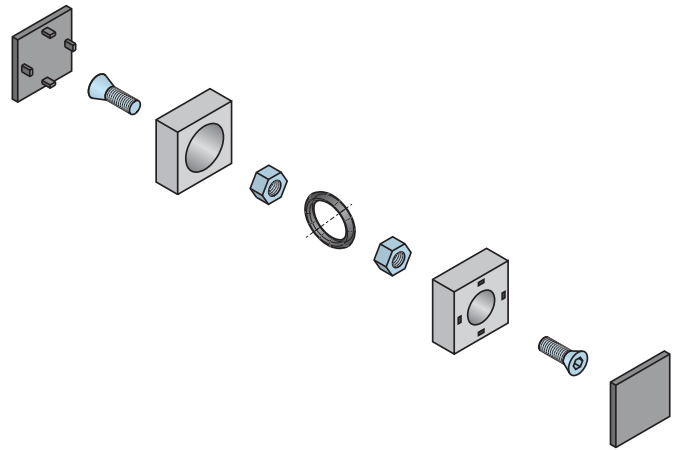

G1/2"

G1/2"-G3/4"
NUOVO

CODICE DI ORDINAZIONE
ORDER CODE

KIT 4-00

CODICE DI ORDINAZIONE
ORDER CODE

KIT 4N-00

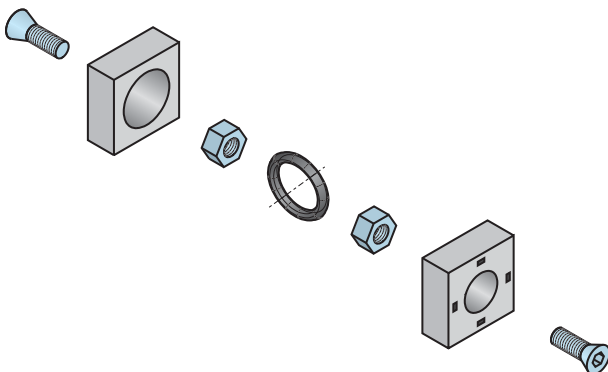

G1"

CODICE DI ORDINAZIONE
ORDER CODE

KIT 6N-00

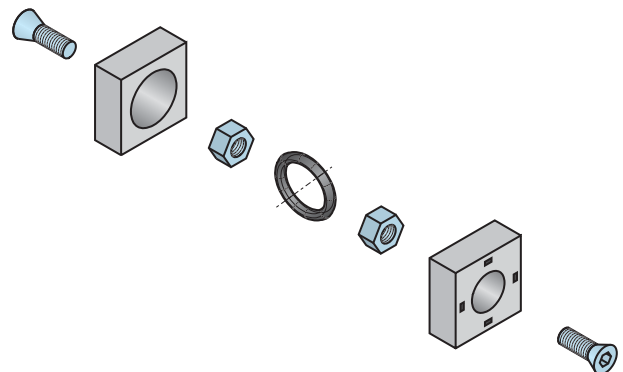

7

SCARICO AUTOMATICO CONDENSA

automatic moisture exhaust

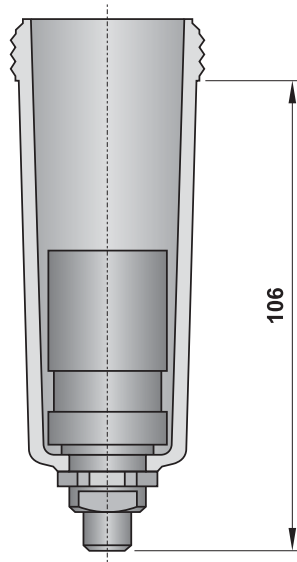

G3/8"

CODICE DI ORDINAZIONE
ORDER CODE

AKS 3

Per l'installazione sostituire la tazza normale con questa tazza dotata di scarico automatico.
This bowl with automatic exhaust replaces the normal filter bowl.

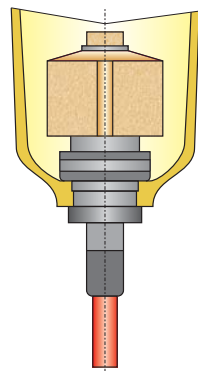

G1/2"

G1"

CODICE DI ORDINAZIONE
ORDER CODE





AKS 4-6

Per l'installazione montare questo elemento all'interno della tazza togliendo il dispositivo per lo scarico semiautomatico.

Lo stesso elemento si utilizza sia per i filtri da G1/2" sia per quelli da G1".

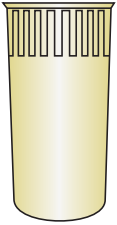
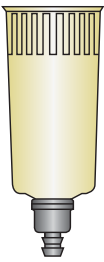
This element replaces the semi-automatic exhaust device located in a normal filter bowl.

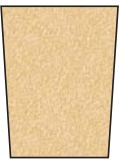
The same element is used for G1/2" and G1" filters.

descrizione <i>description</i>		dimensione <i>size</i>	codice di ordinazione <i>order code</i>	
	TAZZA PER LUBRIFICATORE <i>bowl for lubricator</i>	G1/4"	16.065.0	
		G3/8"	16.067.0	
		G1/2"	16.069.0 + 16.109.0	
		G1"	16.145.0	
	TAZZA PER FILTRO <i>bowl for filter</i>	G1/4"	16.064.0	
		G3/8"	16.132.2	
		G1/2"	16.068.0	
		G1"	16.146.0	
	MEMBRANA PER REGOLATORE DI PRESSIONE <i>diaphragm for pressure regulator</i>	G3/8"-G1/2"	16.098.0	
		G1"	16.137.0	
	ELEMENTO FILTRANTE <i>filter element</i>	25 μm	G1/4"	16.061.0
		5 μm	G1/4"	16.031.0
		30 μm	G3/8"	16.062.0
		5 μm	G3/8"	16.032.0
		30 μm	G1/2"	16.063.0
		5 μm	G1/2"	16.033.0
		30 μm	G1"	16.144.0
		5 μm	G1"	16.171.0
	CUPOLA VISIVA PER LUBRIFICATORE <i>oil view element for lubricator</i>	G1/4"	16.104.0	
		G3/8"-G1/2"	16.105.0	
		G1"	16.140.0	

7

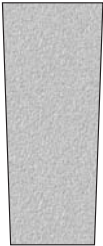
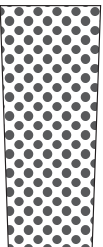
	descrizione <i>description</i>	dimensione <i>size</i>	codice di ordinazione <i>order code</i>
	CARTUCCIA MICROFILTRO <i>sub-micro-filter element</i>	G1/4"	16.183.0
		G3/8"	16.189.0
		G1/2"	16.169.0
		G1"	16.191.0
	ELEMENTO FILTRANTE CARBONE ATTIVO <i>activated carbon filter element</i>	G1/4"	16.184.0
		G3/8"	16.192.0
		G1/2"	16.193.0
		G1"	16.194.0

piastrina di fissaggio a parete per filtri e lubrificatori G1/4"

adaptor for side mounting - filters and lubricators G1/4"

- Utilizzabile per il fissaggio a parete di **filtro e/o lubrificatore**
*It can be used to install **filter** and/or **lubricator***
- Si utilizza in posizione intermedia per il fissaggio di **FIL + LUB**
*To be used in intermediate position to install **FIL + LUB***
- Si utilizza come terminale per il fissaggio di **FIL o LUB**
*To be used as header to install **FIL or LUB***
- **Materiale: alluminio anodizzato**
Material: aluminium (anodize treatment)

CODICE DI ORDINAZIONE
ORDER CODE

16.004.2

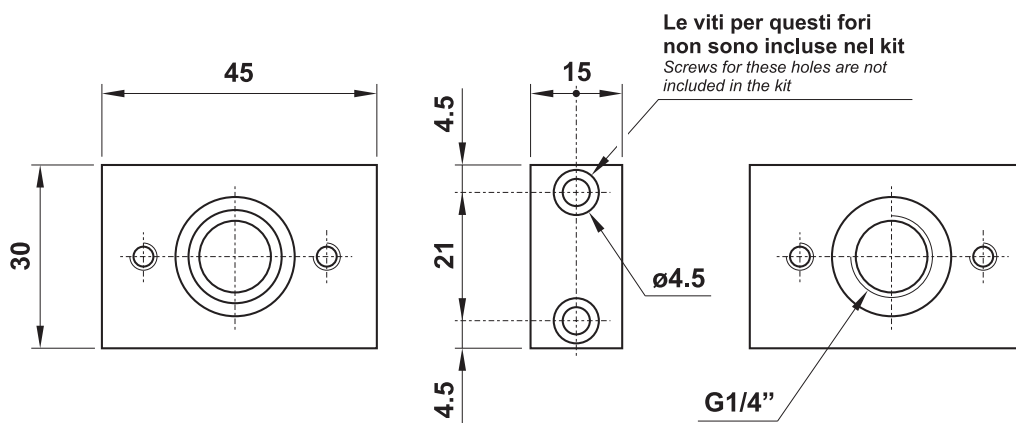

Ogni pezzo è venduto in kit con i particolari necessari al suo assemblaggio
Each element is sold in kit with all necessary pieces for installation

Montaggio in posizione intermedia
Installation in intermediate position

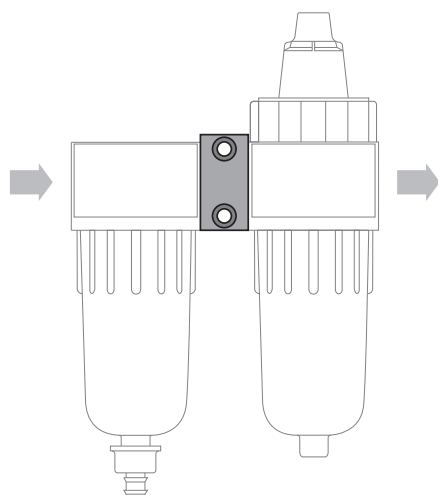

Montaggio come terminale
Installation as header

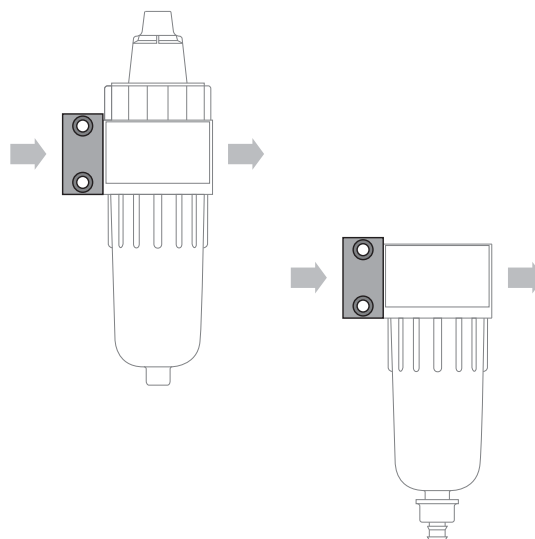

piastrina di fissaggio a parete per regolatori e filtroregolatori G1/4"

adaptor for side mounting - regulators and filter-regulators G1/4"

- Si utilizza in posizione intermedia (cod. **16.005.2**) per il fissaggio di FR+L o FRL
*To be used in intermediate position (code **16.005.2**) to install FR+L or FRL*
- Si utilizza come terminale (cod. **16.006.2**) per il fissaggio di FR o REG
*To be used as header (code **16.006.2**) to install FR or REG*
- Materiale: alluminio anodizzato
Material: aluminium (anodize treatment)

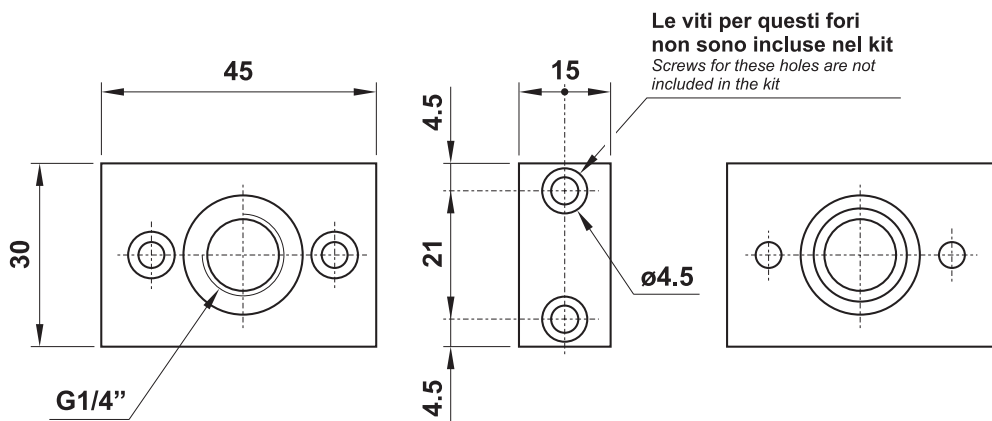

Ogni pezzo è venduto in kit con i particolari necessari al suo assemblaggio
Each element is sold in kit with all necessary pieces for installation

Montaggio in posizione intermedia
Installation in intermediate position

16.005.2

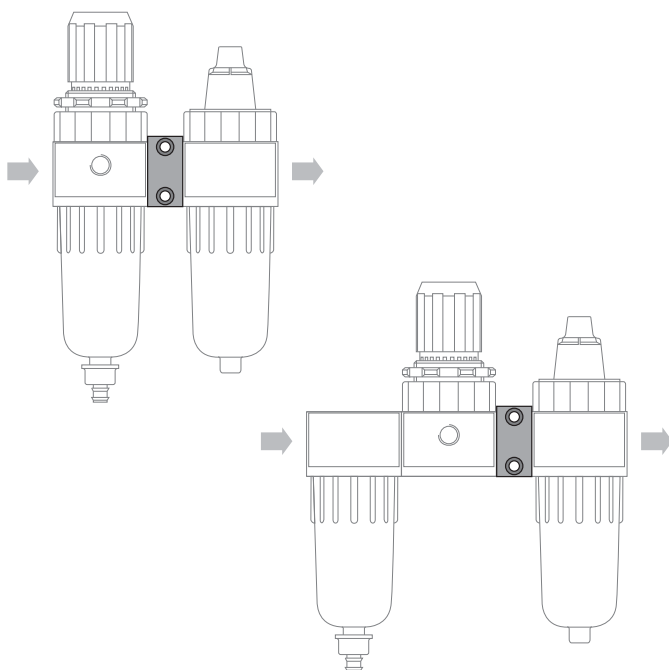

Montaggio come terminale
Installation as header

16.006.2

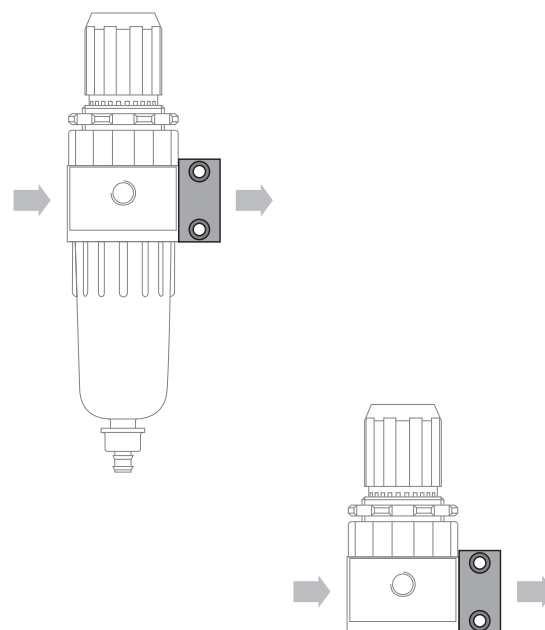

STAFFE E GHIERA DI FISSAGGIO

mounting brackets and ring

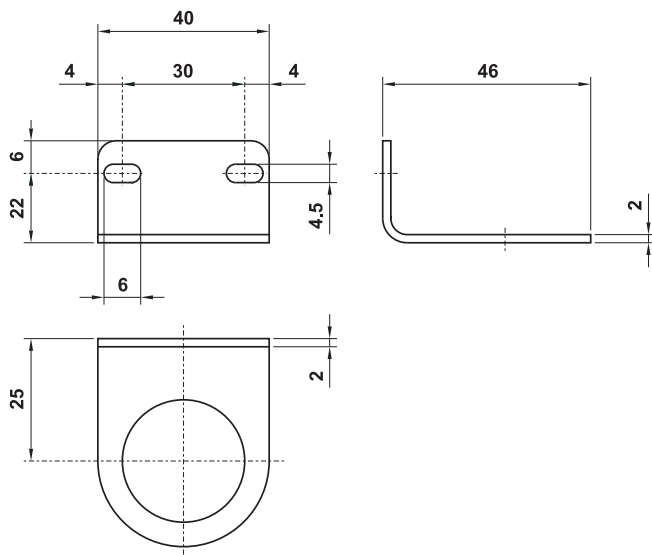

G1/4"

CODICE DI ORDINAZIONE
ORDER CODE

STF 2

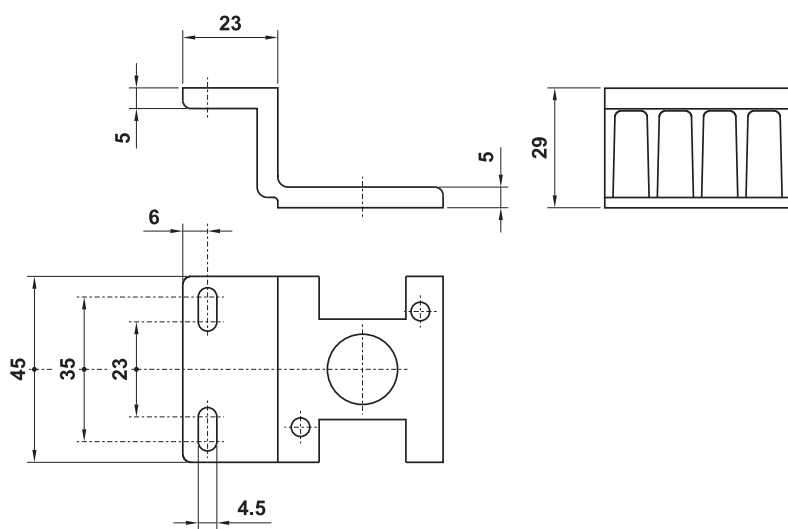

G3/8"

CODICE DI ORDINAZIONE
ORDER CODE

STF 3

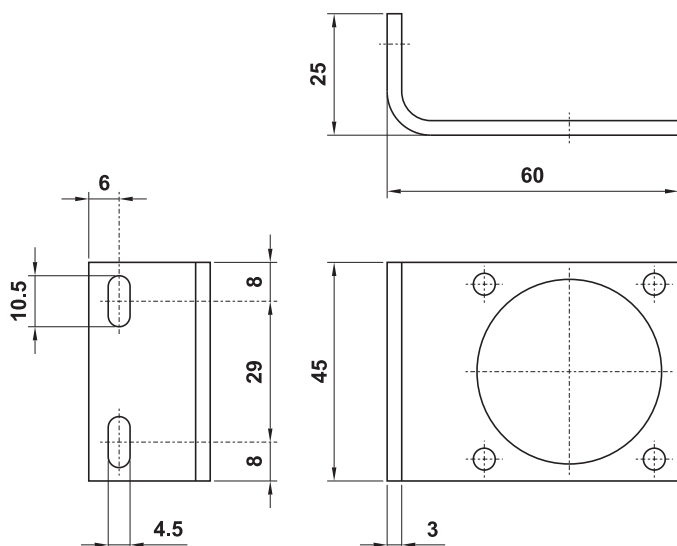

G3/8"

CODICE DI ORDINAZIONE
ORDER CODE

STF 3A

7

STAFFE E GHIERA DI FISSAGGIO

mounting brackets and ring

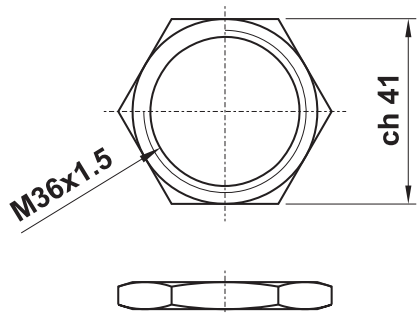

G3/8"

CODICE DI ORDINAZIONE
ORDER CODE

STF 3B

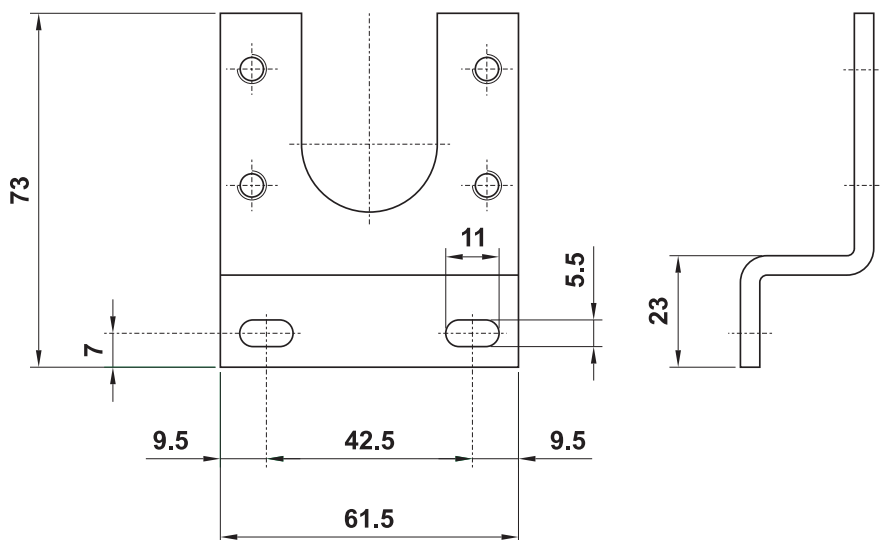

G1/2"

CODICE DI ORDINAZIONE
ORDER CODE

STF 4

STAFFE E GHIERA DI FISSAGGIO

mounting brackets and ring

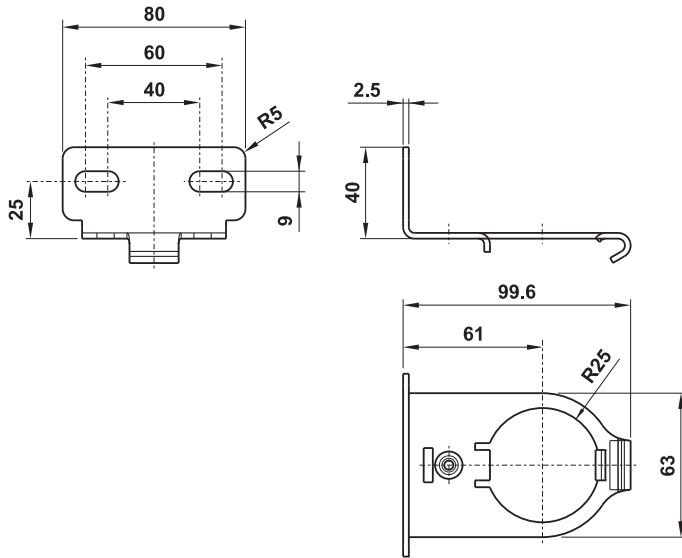

G1"

CODICE DI ORDINAZIONE
ORDER CODE

STF 6N

La sigla si riferisce a una coppia di staffe
The part number is referred to a couple of brackets

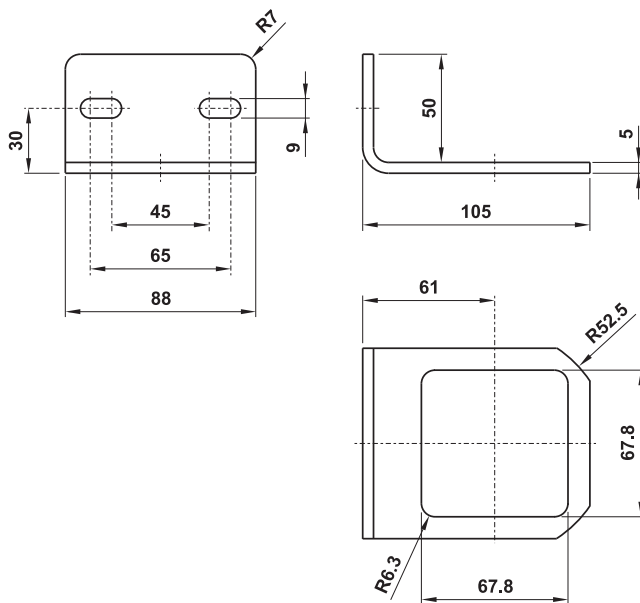

G1"

CODICE DI ORDINAZIONE
ORDER CODE

STF 6NA

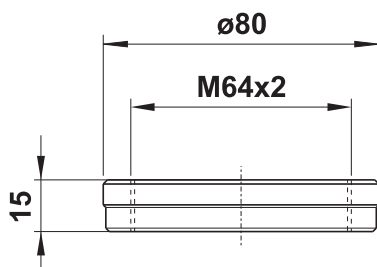

G1"

CODICE DI ORDINAZIONE
ORDER CODE

STF 6NB

7

MANOMETRO

manometer

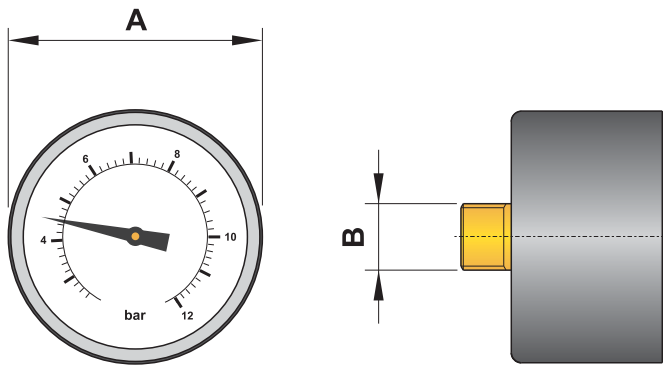

A	B	CODICE DI ORDINAZIONE ORDER CODE	
ø40	G1/8"	M40-00	17.001.0
ø50	G1/8"	M50-00	17.002.0
ø50	G1/4"	M50-01	17.054.0
ø63	G1/4"	M63-00	17.003.0

MANOMETRO IN PLASTICA RETTANGOLARE

rectangular plastic manometer

7

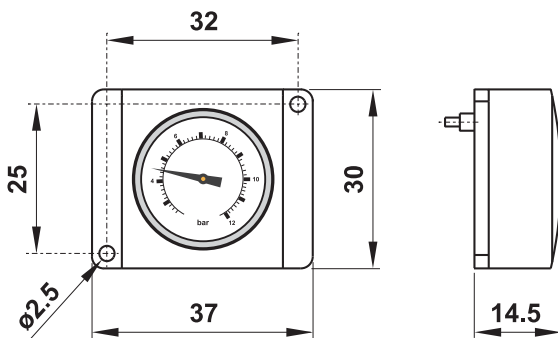

0 ... 12 bar

CODICE DI ORDINAZIONE
ORDER CODE

16.186.0

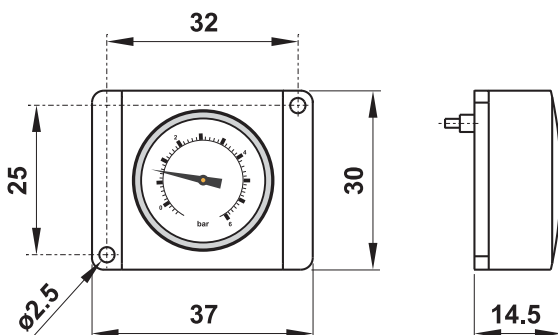

0 ... 6 bar

CODICE DI ORDINAZIONE
ORDER CODE

16.195.0

MANOMETRO CON FLANGIA E STAFFA POSTERIORE

manometer with rear flange and bracket



diametro <i>diameter</i>	filetto <i>thread</i>	campo di pressione <i>pressure range</i>	CODICE DI ORDINAZIONE <i>ORDER CODE</i>
ø40	G1/8"	0 ... 12 bar	17.036.0
ø40	G1/8"	0 ... 6 bar	17.058.0
ø50	G1/8"	0 ... 6 bar	17.052.0