

Complementary valves: shuttle, quick exhaust and check valves

DESCRIPTION

Complementary valves are very important components of the pneumatic circuits. This group includes the:

- **SHUTTLE VALVES:** these valves are used when there is the necessity to convey, in one pipeline, two pneumatic flows coming from two different pipelines without any interference; in fact the compressed air flows from one of the two inlet ports to the working port while the second inlet port is excluded.

- **QUICK EXHAUST VALVES:** air flows from the inlet port to the working port while the exhaust port is closed. By shutting off the inlet port, the compressed air from the working port is exhausted through the exhaust port.

- **CHECK VALVES:** these valves are used to prevent loss of pressure in a pipeline when the inlet is connected to the exhaust; the compressed air can flow freely from the inlet to the working port while the opposite direction is blocked.

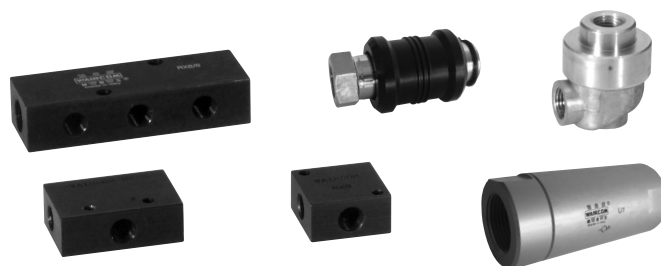

3

SHUTTLE VALVES SERIES DS

TECHNICAL DATA

Operating pressure	0 ÷ 12 bar
Working temperature	0 ÷ +80° C (-20° C with dry air)
Fluid	Filtered air, without lubrication. If lubricated air is used, lubrication should never be interrupted
Port size	G 1/8 - G 1/4 - G 3/8 - G 1/2

MATERIALS

Body	Aluminium alloy
Seals	NBR rubber

DIMENSIONS AND WEIGHTS DS

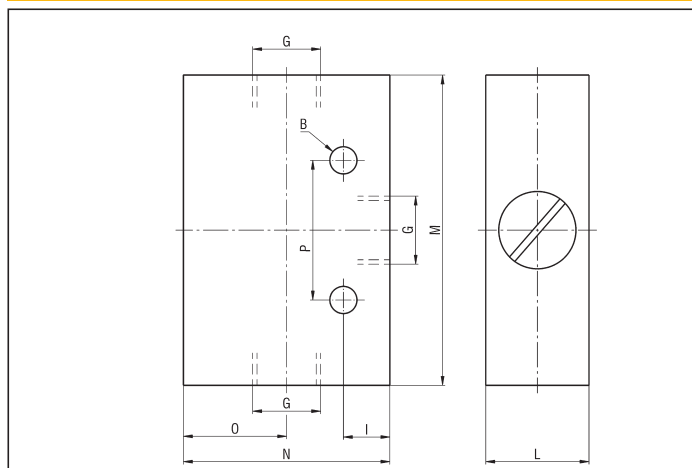

Symbol	B	I	L	M	N	O	P	Flow rate at 6 bar $\Delta P=1$ bar (NI/min)	Pmin (bar)	Weight (g)	G	TYPE
	4,2	6	16	46	31	13	22	700	0,2	60	G 1/8	DS8
	5,2	8	20	60	40	17,5	27	1700	0,4	125	G 1/4	DS4
	6,4	10	25	80	50	21	38	3400	0,3	235	G 3/8	DS3
	6,4	12	30	100	60	26	48	5000	0,6	435	G 1/2	DS2

QUICK EXHAUST VALVES SERIES D3/

TECHNICAL DATA

Operating pressure	0 ÷ 12 bar
Working temperature	0 ÷ +80° C (-20° C with dry air)
Fluid	Filtered air, without lubrication. If lubricated air is used, lubrication should never be interrupted
Port size	G 1/4 - G 1/2 - G 3/4

MATERIALS

Body	Aluminium alloy
Seals	NBR rubber
Bottom	Aluminium alloy

DIMENSIONS AND WEIGHTS D3/

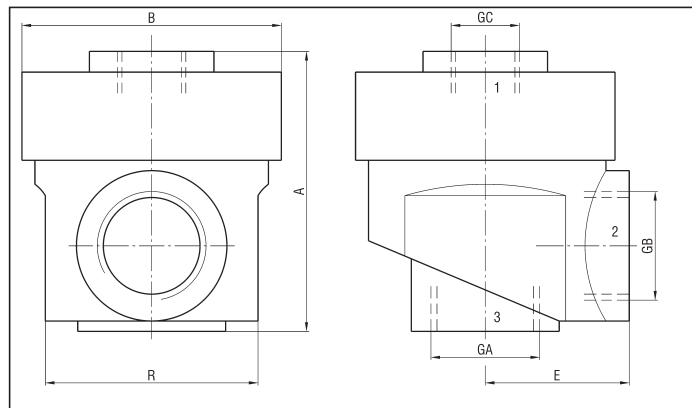

Symbol	A	B	E	R	Flow rate from 1 to 2 at 6 bar $\Delta P=1$ bar (NI/min)	Flow rate from 2 to 3 at 6 bar free exhaust (NI/min)	Pmin (bar)	Weight (g)	GA	GB	GC	TYPE
	38	35	19,5	27	520	2300	0,2	70	G 1/4	G 1/4	G 1/8	D3/4
	43	35	19,5	27	610	2300	0,2	75	G 1/4	G 1/4	G 1/4	D3/4B
	54	50	27,5	41	1520	4300	0,2	135	G 1/2	G 1/2	G 1/4	D3/2
	58	50	27,5	41	2220	4300	0,2	140	G 1/2	G 1/2	G 1/2	D3/2B
	82	82	44	70	4400	6000	0,2	510	G 3/4	G 3/4	G 1/2	D3/15

Complementary valves: check and slide valves, distribution frames

CHECK VALVES SERIES U

TECHNICAL DATA

Operating pressure	0 ÷ 12 bar
Working temperature	0 ÷ +80° C (-20° C with dry air)
Fluid	Filtered air, without lubrication. If lubricated air is used, lubrication should never be interrupted
Port size	G 1/8 - G 1/4 - G 1/2 - G 1

MATERIALS

Body	Anodized aluminium
Piston	Brass
Seals	NBR rubber
Spring	Stainless steel

DIMENSIONS AND WEIGHTS U

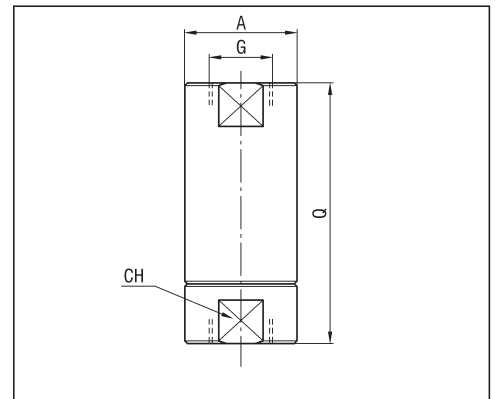

Symbol	CH	A	Q	Flow rate at 6 bar $\Delta P=1$ bar (NI/min)	Pmin (bar)	Weight (g)	G	TYPE
	13	15	34	70	0,2	25	G 1/8	U8
	19	21	48	700	0,7	75	G 1/4	U4
	19	21	48	725	0,2	75	G 1/4	U4/SM
	27	30	66	2750	0,2	170	G 1/2	U2
	50	50	110	5100	0,2	1000	G 1	U1
	19	21	48	800	0,2	75	G 1/4	U4/SM2

SLIDE VALVES SERIES VC

TECHNICAL DATA

Operating pressure	0 ÷ 16 bar
Working temperature	0 ÷ +80° C (-10° C with dry air)
Fluid	Filtered air, without lubrication. If lubricated air is used, lubrication should never be interrupted
Port size	G 1/8 - G 1/4 - G 3/8 - G 1/2

MATERIALS

Body	Nickel-plated brass
Slide	Anodized aluminium
Seals	NBR rubber

DIMENSIONS AND WEIGHTS VC

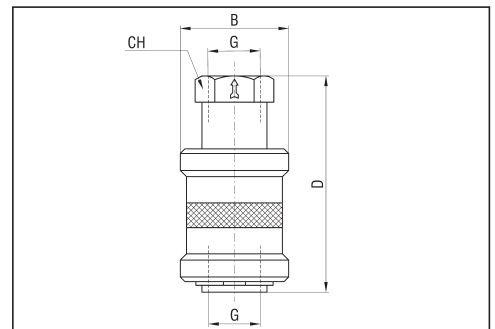

CH	B	Flow rate at 6 bar $\Delta P=1$ bar (NI/min)	D	Weight (g)	G	TYPE
14	25	700	48	54	G 1/8	VC-01
17	30	1500	58	102	G 1/4	VC-02
22	35	2200	68	153	G 3/8	VC-03
27	40	3400	80	204	G 1/2	VC-04

DISTRIBUTION FRAMES SERIES RX

TECHNICAL DATA

Fluid	Air, oil, water
Port size	G 1/8 - G 1/4 - G 3/8 - G 1/2

MATERIALS

Body	Anodized aluminium alloy
------	--------------------------

DIMENSIONS AND WEIGHTS RX

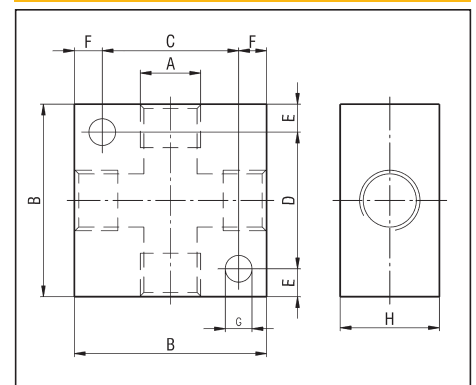

B	C	D	E	F	G	H	A	Weight (g)	TYPE
31	23	22	4,5	4	4,3	16	G 1/8	35	RX8
40	30	27	6,5	5	5,3	20	G 1/4	70	RX4
50	38	39	5,5	6	6,3	25	G 3/8	130	RX3
50	38	39	5,5	6	6,3	25	G 1/2	115	RX2

DIMENSIONS AND WEIGHT RX8/6

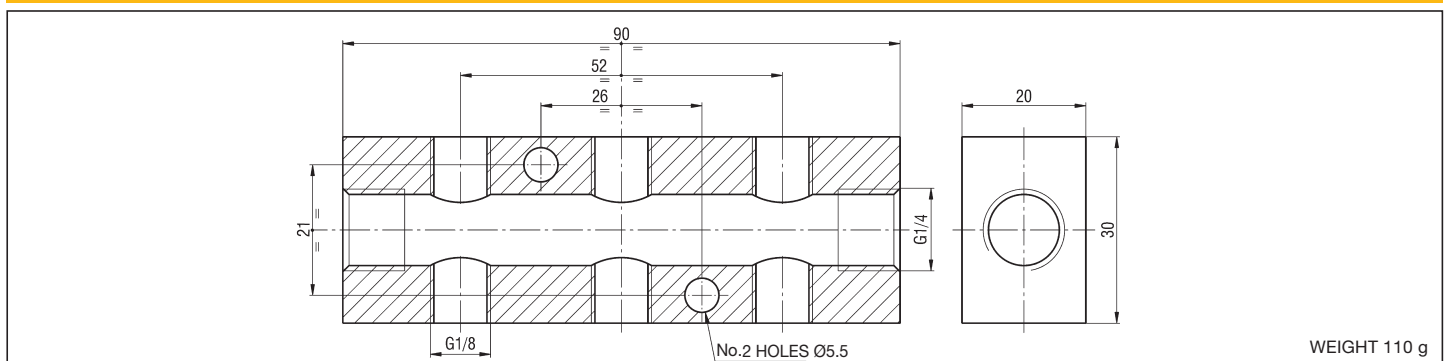

WEIGHT 110 g