



**PNEUMAX**



**SERIES F300, PVF and PVA**  
COMPONENTS FOR FLUID CONTROL

### General details

PNEUMAX offer a vast range of solenoid valves in brass and stainless steel designed to control air, water, steam and all fluids that are compatible with the materials (body and seals) used in the range.

The solenoid valves are 2 or 3-way, normally closed, normally open, general service, direct acting or servo-actuated, with connections available in NPT & BSP threads from G1/8" up to G2", with a working pressure range from vacuum to 100 bar.

Solenoid valves are available with coils that conform to CESI 03 ATEX 344 certification for explosive environments.

Our technical office ensures the highest standard of skill and understanding for the widest variety of applications, ensuring that the best possible solutions are found.

### Versions manufactured

**Direct action 2-way:** 2-way solenoid valves have an input connection and an output connection machined in the valve body, the orifice being intercepted by the plunger mounted in the core tube.

They can be **normally closed (2/2 NC)**, in this case the fluid is intercepted by the plunger at rest, with electricity applied, the input orifice is opened and the media reaches the intended use.

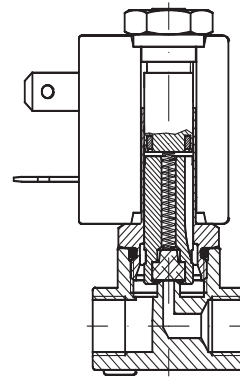

They can be **normally open (2/2 NO)**, in this case at rest the orifice remains open without electricity applied, the media reaches the intended use. When electricity is applied the input orifice closes.

Performance in both cases depends solely on the magnetic field produced by the solenoid coil.

The solenoid valves can also work at zero pressure.

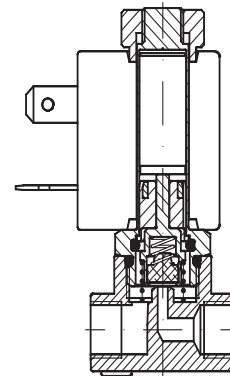

**Direct action 3-way:** 3-way solenoid valves have an input and an output connection in the valve body and an exhaust connection fitted in the fixed core. The input and exhaust orifices are intercepted directly by the plunger fitted within the core tube.

They can be **normally closed (3/2 NC)** and in this case, at rest, the incoming fluid is intercepted by the plunger and output port in connected to the exhaust port. Applying electrical power, the input orifice is opened and feed is supplied to the output. Exhaust is closed.

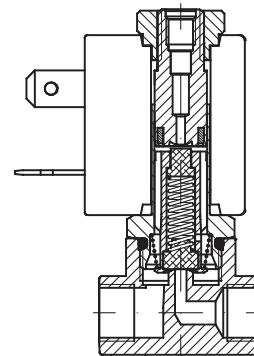

They can be **normally open (3/2 NO)** and in this case, at rest, the input orifice is open without electricity applied, the media reaches the intended use. Exhaust is closed. Applying power, the input orifice closes and the output discharges through the exhaust port.

Performance in both cases depends solely on the magnetic field produced by the solenoid coil.

The solenoid valves can also work at zero pressure.

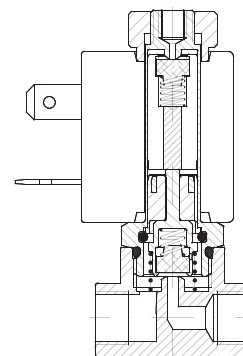

**Servo actuated**

With large-sized passage orifices, the static pressure value that needs to be overcome by the magnetic field produced by the coil increases. These solenoid valves are used to control high-pressure values with large diameter bores. In these models, the fluid helps in the opening or closing of the main plunger.

They can be **normally closed (2/2 NC)** and have an input and a utilisation connection machined into the valve body and at rest the fluid is intercepted by the main plunger, which can be either diaphragm or a piston. In this condition, the fluid acts on both faces of the main plunger through a pinhole contributing to closure of the plunger.

Applying electrical power, the secondary, or pilot, orifice opens leading to the exhaust of the fluid, which acts to close the main plunger. Greater force is thus applied when opening, the plunger is raised from the orifice and allows the media to flow to the output. In these versions, performance does not depend solely on the magnetic field produced by the coil; a minimum input pressure is also needed so as to move the diaphragm or the piston overcoming its rigidity and to keep it raised from the main orifice. ( $\Delta p$  minimum performance).

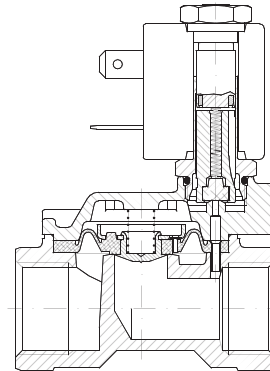

They can be **normally open (2/2 NO)**, and have an input and output connection machined into the valve body, and at rest the secondary plunger communicates with output, a minimum-pressure difference between the feed and the output causes the main shutter to rise, leading to it opening.

Applying electrical power, the secondary orifice closes and equilibrium between the pressure on the two faces of the main shutter is reinstated, and so it returns to its closed position on the main orifice. In this version a minimum working pressure is also needed.

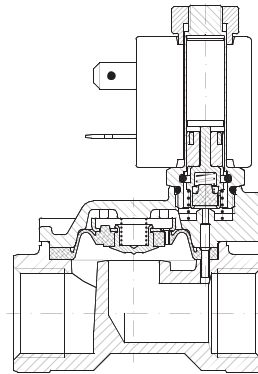

**Sealing materials**

Designation	Trade names	General characteristics	Field of use
FPM (Fluorocarbon)	VITON TECNOFLO FLUOREL	A synthetic hexa-fluoropropylene-based elastomer. Excellent resistance to high temperatures. Excellent resistance to ozone, oxygen, mineral oils, synthetic hydraulic fluids, fuels, hydrocarbons and many chemical products. Not specific for superheated steam.	For general use up to 130 °C



### Resistance to fluids

The table below serves to general information relating to the compatibility between FPM (fluorocarbon) and a number of neutral fluids. Where there are corrosive fluids, in order to establish compatibility, it is important to be aware of all the data relating to use: temperature, concentration and composition of the fluid.

Fluid	
Ethyl acetate	Non Compatible
Acetylene	Compatible
Vinegar	Non Compatible
Acetone	Non Compatible
Calcareous water	Compatible
Hot water <75°C	Compatible
Hot water and steam <140°C	Non Compatible
Water with glycol	Compatible
Deionised water	Compatible
Demineralised water	Compatible
Hydrogen peroxide	Compatible
Soapy water	Compatible
Carbon dioxide (liquid)	Non Compatible
Dry carbon dioxide (gas)	Compatible
Argon	Compatible
Nitrogen	Compatible
Petrol/Gasoline	Compatible
Benzol	Non Compatible
Butane	Compatible
Chloroform	Non Compatible
Ethyl Chloride	Compatible
Methyl chloride	Non Compatible
Helium	Compatible
Heptane	Compatible
Hexane	Compatible
Ethane	Compatible
Ethanol	Non Compatible
Formaldehyde	Compatible
Freon	Non Compatible
Natural gas	Compatible
Diesel oil	Compatible
Glycerine	Compatible
Ethylene glycol	Compatible
Hydrogen	Compatible
Isobutane	Compatible
Isopentane	Compatible
Methane	Compatible
Methanol	Non Compatible
Calcium monoxide	Compatible
Neon	Compatible
Nitrobenzene	Non Compatible
Mineral oil	Compatible
Oxygen	Compatible
Pentane-n	Compatible
Propanol-n	Compatible
Propane-n	Compatible
Carbon sulphide	Non Compatible
Toluene	Compatible
Dry trichloroethylene	Compatible
Xylene	Compatible



**Solenoid valves for fluids - F3105**  
**Brass body, with G connector (ISO228) 1/8"**

FLUID CONTROL

2-way solenoid normally closed valve, direct plunger operation

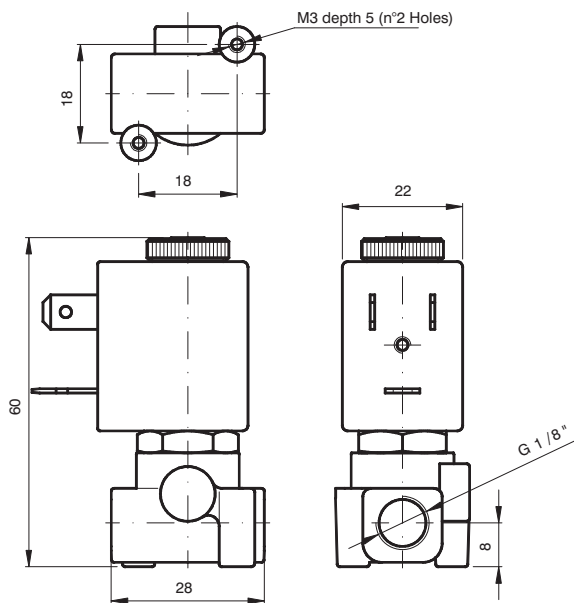

CODE "V"=Seals in FPM ⊕ = Bobina	Connection G ISO 228	Orifice (mm)	KV (m <sup>3</sup> /h)	Differential pressure (bar)			Power Consumption			Coil ⊕		Temp range (°C)
				Min	Max		AC Inrush	VA Holding	DC Watt	Series	Size	
					AC	DC						
F3105AV25⊕	1/8"	2,5	0,14	0	8	5,5	12	8	6,5	MI	22	-10 +130

N.B. For use with steam, maximum admitted pressure PS is 6 bar (relative pressure) with seals in FPM  
 Example: F3105AV25b => F3105AV25MI58:  
 2-way normally closed, direct acting solenoid valve with G connector (ISO228) 1/8", Seals in FPM, Orifice 2,5 mm, Coil 220V 50/60Hz (MI58, size 22).

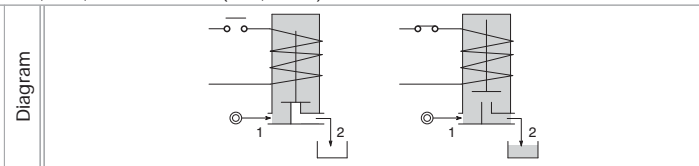
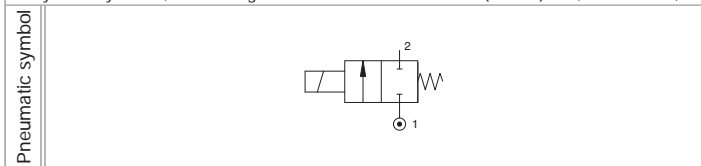

**Operational characteristic**

- Brass Body
- Guide pipe in Brass
- Mobile and fixed core in Stainless Steel
- Springs in Stainless Steel
- Sealing assemblies in FPM
- OPTIONS (if requested):
- Manual operation
- Surface treatment in chemical nickel-plating
- Guide pipe in Stainless Steel
- For use with oxygen

**Technical characteristic**

Maximum admitted pressure (bar)	50
Maximum fluid viscosity (mm <sup>2</sup> /s)	25cSt
Ambient temperature: with class F coil (°C)	-10 +55
Mounting position	indifferent
Weight (gr.) with MI Series Coil	130

2-way solenoid normally closed valve, direct plunger operation

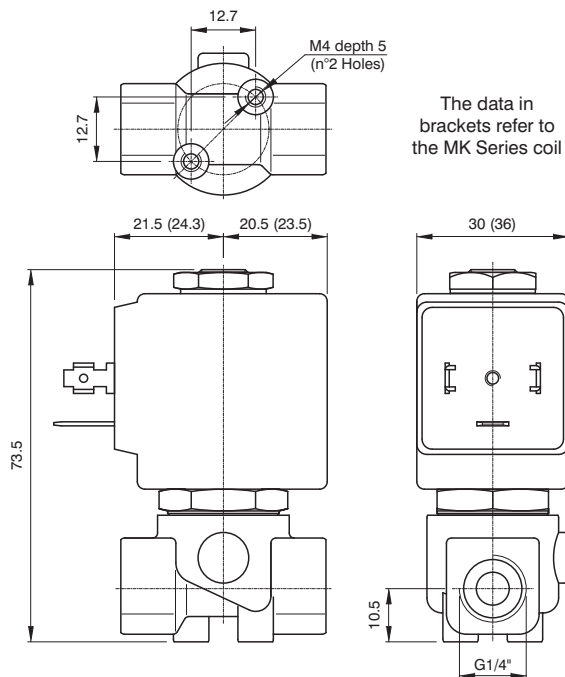

The data in brackets refer to the MK Series coil

CODE "V"=Seals in FPM ⊕ = Coil	Connection G ISO 228	Orifice (mm)	KV (m³/h)	Differential pressure (bar)			Power Consumption			Coil ⊕		Temp. range (°C)
				Min	Max		AC Inrush	VA Holding	DC Watt	Series	Size	
					AC	DC						
F3106BV15⊕	1/4"	1,5	0,07	0	30	26	20	15	10	MG	30	-10 +140
F3106BV20⊕	1/4"	2,0	0,1	0	22	20	20	15	10	MG	30	
F3106BV25⊕	1/4"	2,5	0,15	0	16	14	20	15	10	MG	30	
F3106BV35⊕	1/4"	3,5	0,32	0	10	8	20	15	10	MG	30	
F3106BV45⊕	1/4"	4,5	0,41	0	6,5	3,5	20	15	10	MG	30	
F3106BV52⊕	1/4"	5,2	0,47	0	4	1,8	20	15	10	MG	30	
F3106BV64⊕	1/4"	6,4	0,64	0	3	1	20	15	10	MG	30	
F3106BV15⊕	1/4"	1,5	0,07	0	80	80	40	30	27	MK	36	
F3106BV20⊕	1/4"	2,0	0,1	0	50	40	40	30	27	MK	36	
F3106BV25⊕	1/4"	2,5	0,15	0	35	33	40	30	27	MK	36	
F3106BV35⊕	1/4"	3,5	0,32	0	20	19	40	30	27	MK	36	
F3106BV45⊕	1/4"	4,5	0,41	0	14	13	40	30	27	MK	36	
F3106BV52⊕	1/4"	5,2	0,47	0	10	9	40	30	27	MK	36	
F3106BV64⊕	1/4"	6,4	0,64	0	5	4,5	40	30	27	MK	36	

N.B. For use with steam, maximum admitted pressure PS is 6 bar (relative pressure) with seals in PTFE and 2.5 bar with seals in EPDM  
Example: F3106BV52b => F3106BV52MG58:  
2-way normally closed, direct acting solenoid valve with G connector (ISO228) 1/4", Seals in FPM, Orifice 5.2 mm, Coil 220V 50/60Hz (MG58, size 30).

Pneumatic symbol

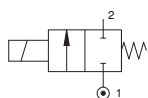

Diagram

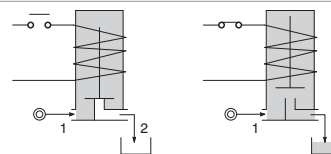

Operational characteristic

- Brass Body
- Guide pipe in Stainless Steel
- Mobile and fixed core in Stainless Steel
- Springs in Stainless Steel
- Sealing assemblies in FPM
- **OPTIONS (if requested):**
- Manual operation
- Surface treatment in chemical nickel-plating
- Inserted stainless steel seating
- For use with oxygen

Technical characteristic

Maximum admitted pressure (bar)	80
Maximum fluid viscosity (mm <sup>2</sup> /s)	25cSt
Ambient temperature: with class F coil (°C)	-10 +55
Ambient temperature: with class H coil (°C)	-10 +80
Mounting position	indifferent
Weight (gr.) with MG Series Coil	300
Weight (gr.) with MK Series Coil	380



**Solenoid valves for fluids - F3106**  
**Brass body, with G connector (ISO228) 1/2"**

2-way solenoid normally closed valve, direct plunger operation

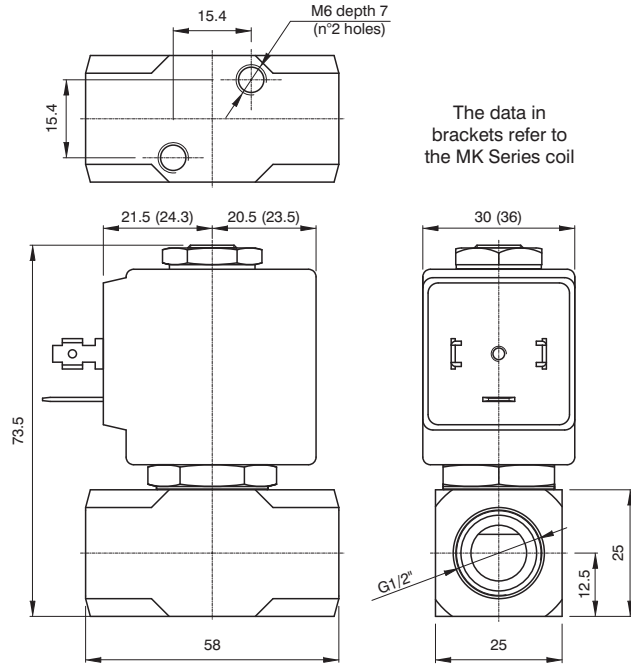

The data in brackets refer to the MK Series coil

CODE "V"=Seals in FPM "E" = Coil	Connection G ISO 228	Orifice (mm)	KV (m <sup>3</sup> /h)	Differential pressure (bar)			Power Consumption			Coil "E"		Temp. range (°C)
				Min	Max		AC Inrush	VA Holding	DC Watt	Series	Size	
					AC	DC						
F3106DV45E	1/2"	4,5	0,41	0	6,5	3,5	20	15	10	MG	30	-10 +140
F3106DV52E	1/2"	5,2	0,47	0	4	1,8	20	15	10	MG	30	
F3106DV64E	1/2"	6,4	0,64	0	3	1	20	15	10	MG	30	
F3106DV45E	1/2"	4,5	0,41	0	14	13	40	30	27	MK	36	
F3106DV52E	1/2"	5,2	0,47	0	10	9	40	30	27	MK	36	
F3106DV64E	1/2"	6,4	0,64	0	5	4,5	40	30	27	MK	36	

N.B. For use with steam, maximum admitted pressure PS is 6 bar (relative pressure) with seals in PTFE and 2.5 bar with seals in EPDM

Example: F3106DV52b => F3106DV52MK5:

2-way normally closed, direct acting solenoid valve with G connector (ISO228) 1/2", Seals in FPM, Orifice 5.2 mm, Coil 24V DC (MK5, size 36).

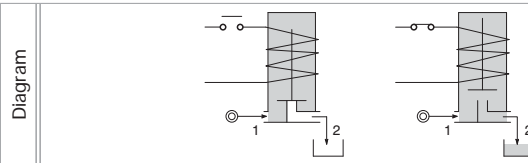
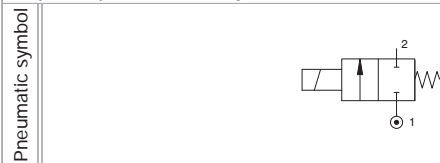

Operational characteristic	Technical characteristic	
- Brass Body.	Maximum admitted pressure (bar)	80
- Guide pipe in Stainless Steel	Maximum fluid viscosity (mm <sup>2</sup> /s)	25cSt
- Mobile and fixed core in Stainless Steel	Ambient temperature: with class F coil (°C)	-10 +55
- Springs in Stainless Steel	Ambient temperature: with class H coil (°C)	-10 +80
- Sealing assemblies in FPM	Mounting position	indifferent
- <b>OPTIONS (if requested):</b>	Weight (gr.) with MG Series Coil	300
- Manual operation	Weight (gr.) with MK Series Coil	380
- Surface treatment in chemical nickel-plating		
- For use with oxygen		

2-Way normally closed solenoid valve, servo-actuated diaphragm

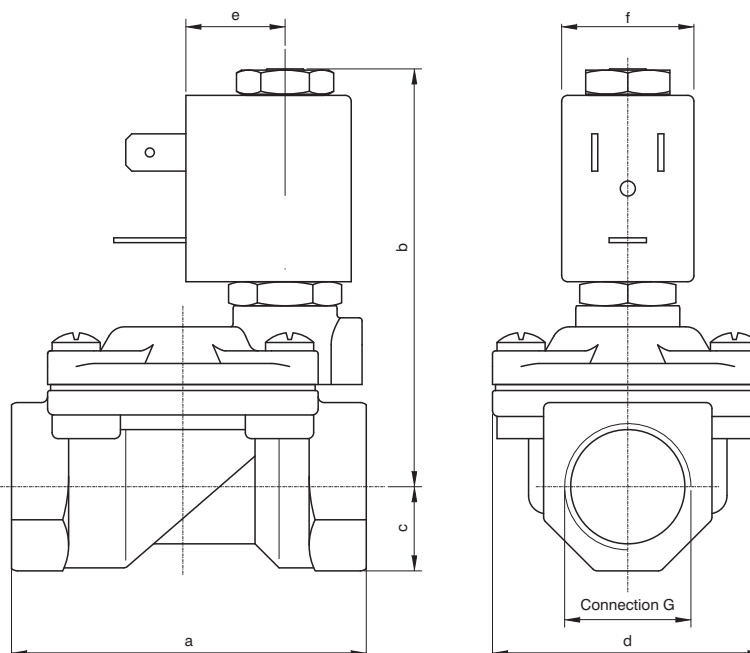
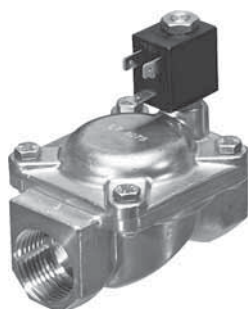

CONNECTION	a	b	c	d	e	f	Weight (gr.)
G1/4" Ø10	49	65	11	32	16	22	230
G3/8" Ø12	59	70	14	45	16	22	420
G1/2" Ø12	59	70	14	45	16	22	390
G3/4"	79	76	18	55	16	22	650
G1"	96	85	20	72	16	22	1050
G1" 1/4	119	92	25	85	16	22	1700

CODE "V" = Seals in FPM "E" = Coil	Connection G ISO 228	Orifice (mm)	KV (m³/h)	Differential pressure (bar)			Power Consumption			Coil "E"		Temp. range (°C)
				Min	Max		AC Inrush	VA Holding	DC Watt	Series	Size	
					AC	DC						
F3107BV10E	1/4"	10	1,5	0,15	15	15	12	8	6,5	MI	22	-10 +140
F3107CV12E	3/8"	12	2,2	0,15	15	15	12	8	6,5	MI	22	
F3107DV12E	1/2"	12	2,5	0,15	15	15	12	8	6,5	MI	22	
F3107EV18E	3/4"	18	5,5	0,15	13	13	12	8	6,5	MI	22	
F3107FV25E	1"	24	10,2	0,15	10	10	12	8	6,5	MI	22	
F3107GV30E	1"1/4	30	15	0,15	10	10	12	8	6,5	MI	22	

N.B. For use with steam maximum admitted pressure PS is 2.5 bar (relative pressure)

Example: F3107BV10b => F3107BV10MI5:

2-Way normally closed solenoid valve, servo-actuated diaphragm with Connector G (ISO228) 1/4", Seals in FPM, Orifice 10 mm, Coil 24V DC (MI5, size 22).

Pneumatic symbol

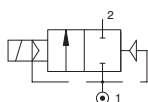

Diagram

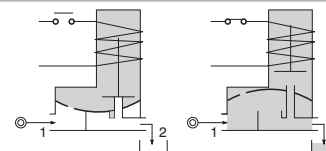

Operational characteristic

- Body and cover in Brass
- Guide pipe in Stainless Steel
- Mobile and fixed core in Stainless Steel
- Springs in Stainless Steel
- Sealing assemblies in FPM
- **OPTIONS (if requested):**
- Manual operation
- Surface treatment in chemical nickel-plating
- Coil for potentially explosive environments meeting 'ATEX standards Ex m Serie XME':
- Version with slowed commutation
- Version for vacuum (air/gas)
- Version for use with oxygen
- "SVGW/SSIGE" approved versions.

Technical characteristic

Minimum differential pressure (bar)	0,15
Maximum admitted pressure (bar)	25
Maximum fluid viscosity (mm <sup>2</sup> /s)	25cSt
Ambient temperature: with class F coil (°C)	-10 +55
Ambient temperature: with class H coil (°C)	-10 +80
Mounting position	Preferably with coil upwards



**Solenoid valves for fluids - F3107**  
**Body and cover in Brass, with Connector G (ISO228) 1" 1/4" - 2"**

FLUID CONTROL

**2-Way normally closed solenoid valve, servo-actuated diaphragm**

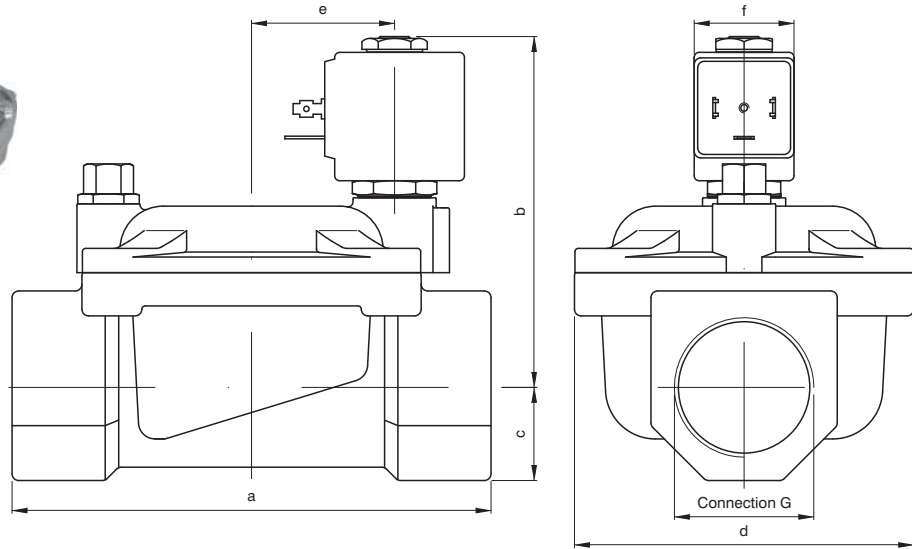

CONNECTION	a	b	c	d	e	f	Weight (gr.)
G1" 1/4	142	105	28	102	21	30	3000
G1" 1/2	142	105	28	102	21	30	2850
G2"	158	115	35	119	21	30	4300

CODE "V" = Seals in FPM ⊕ = Coil	Connection G ISO 228	Orifice (mm)	KV (m³/h)	Differential pressure (bar)			Power Consumption			Coil ⊕		Temp. range (°C)
				Min	Max		AC Inrush	VA Holding	DC Watt	Series	Size	
					AC	DC						
F3107GV37⊕	1" 1/4"	37	18	0,15	10	10	20	15	10	MG	30	-10 +140
F3107HV37⊕	1" 1/2"	37	21	0,15	10	10	20	15	10	MG	30	
F3107IV50⊕	2"	50	36	0,15	10	10	20	15	10	MG	30	

N.B. For use with steam maximum admitted pressure PS is 2.5 bar (relative pressure)

Example: F3107GV37b => F3107GV37MG5:

2-Way normally closed solenoid valve, servo-actuated diaphragm with Connector G (ISO228) 1" 1/4", Seals in FPM, Orifice 37 mm, Coil 24V DC (MG5, size 30).

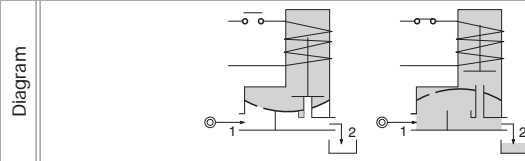
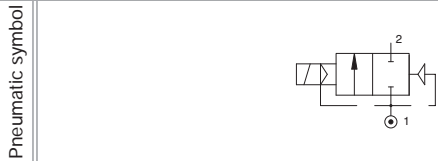

**Operational characteristic**

- Body and cover in Brass
- Guide pipe in Stainless Steel
- Mobile and fixed core in Stainless Steel
- Springs in Stainless Steel
- Sealing assemblies in FPM
- **OPTIONS (if requested):**
- Manual operation
- Surface treatment in chemical nickel-plating
- Version for vacuum (air/gas)

**Technical characteristic**

Minimum differential pressure (bar)	0,15 - 3
Maximum admitted pressure (bar)	80
Maximum fluid viscosity (mm <sup>2</sup> /s)	25cSt
Ambient temperature: with class F coil (°C)	-10 +55
Ambient temperature: with class H coil (°C)	-10 +80
Mounting position	Preferably with coil upwards

2-way solenoid normally closed valve, direct plunger operation

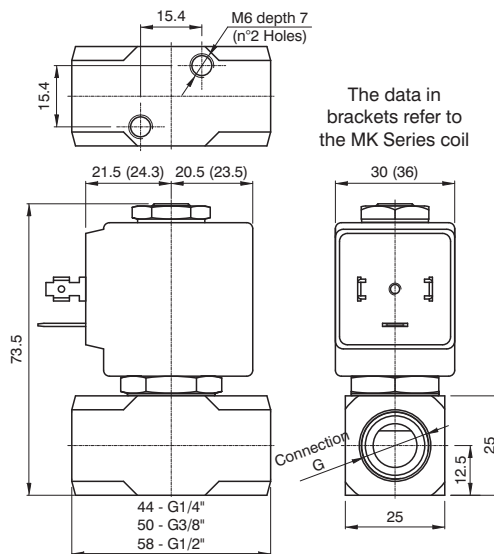

CODE "V"=Seals in FPM ⊕ = Coil	Connection G ISO 228	Orifice (mm)	KV (m³/h)	Differential pressure (bar)			Power Consumption			Coil ⊕		Temp. range (°C)
				Min	Max		AC Inrush	VA Holding	DC Watt	Series	Size	
					AC	DC						
F3110BV25⊕	1/4"	2,5	0,15	0	16	14	20	15	10	MG	30	-10 +140
F3110BV35⊕	1/4"	3,5	0,32	0	10	8	20	15	10	MG	30	
F3110BV45⊕	1/4"	4,5	0,41	0	6,5	3,5	20	15	10	MG	30	
F3110CV35⊕	3/8"	3,5	0,32	0	10	8	20	15	10	MG	30	
F3110CV52⊕	3/8"	5,2	0,47	0	4	1,8	20	15	10	MG	30	
F3110DV35⊕	1/2"	3,5	0,32	0	10	8	20	15	10	MG	30	
F3110DV52⊕	1/2"	5,2	0,47	0	4	1,8	20	15	10	MG	30	
F3110DV64⊕	1/2"	6,4	0,64	0	3,5	1	20	15	10	MG	30	
F3110BV25⊕	1/4"	2,5	0,15	0	35	33	40	30	27	MK	36	
F3110BV35⊕	1/4"	3,5	0,32	0	20	19	40	30	27	MK	36	
F3110BV45⊕	1/4"	4,5	0,41	0	14	13	40	30	27	MK	36	
F3110CV35⊕	3/8"	3,5	0,32	0	20	19	40	30	27	MK	36	
F3110CV52⊕	3/8"	5,2	0,47	0	10	9	40	30	27	MK	36	
F3110DV35⊕	1/2"	3,5	0,32	0	20	19	40	30	27	MK	36	
F3110DV52⊕	1/2"	5,2	0,47	0	10	9	40	30	27	MK	36	
F3110DV64⊕	1/2"	6,4	0,64	0	5	4,5	40	30	27	MK	36	

N.B. For use with steam, maximum admitted pressure PS is 6 bar (relative pressure)

Example: F3110BV25b => F3110BV25MG5:

2-way solenoid normally closed valve, direct plunger operation with Connector G (ISO228) 1/4", Seals in FPM, Orifice 2,5 mm, Coil 24V DC (MG5, size 30).

Pneumatic symbol

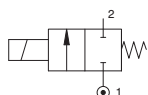

Diagram

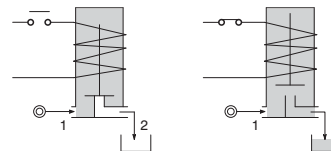

Operational characteristic

- Stainless Steel Body
- Guide pipe in Stainless Steel
- Mobile and fixed core in Stainless Steel
- Springs in Stainless Steel
- Sealing assemblies in FPM

OPTIONS (if requested):

- Manual operation
- Advance ring in silver
- For use with oxygen

Technical characteristic

Maximum admitted pressure (bar)	100
Maximum fluid viscosity (mm <sup>2</sup> /s)	25cSt
Ambient temperature: with class F coil (°C)	-10 +55
Ambient temperature: with class H coil (°C)	-10 +80
Mounting position	indifferent
Weight (gr.) with MG Series Coil	360
Weight (gr.) with MK Series Coil	440



**Solenoid valves for fluids - F3111**  
**Stainless Steel Body, with Connector G (ISO228) 1/8"**

FLUID CONTROL

2-way solenoid normally closed valve, direct plunger operation

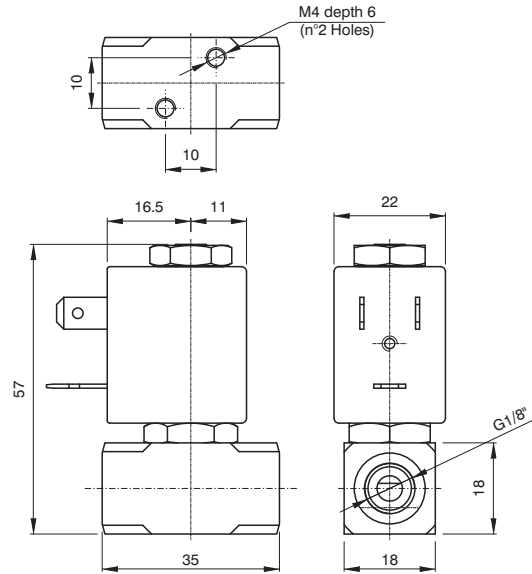

CODE "V" = Seals in FPM ⊕ = Coil	Connection G ISO 228	Orifice (mm)	KV (m³/h)	Differential pressure (bar)			Power Consumption			Coil ⊕		Temp. range (°C)
				Min	Max		AC Inrush	VA Holding	DC Watt	Series	Size	
					AC	DC						
F3111AV12⊕	1/8"	1,2	0,04	0	25	25	12	8	6,5	MI	22	-10 +140
F3111AV15⊕	1/8"	1,5	0,06	0	16	16	12	8	6,5	MI	22	
F3111AV20⊕	1/8"	2	0,09	0	12	10	12	8	6,5	MI	22	

N.B. For use with steam, maximum admitted pressure PS is 6 bar (relative pressure)

Example: F3111AV12b => F3111AV12MI56:

2-way solenoid normally closed valve, direct plunger operation with Connector G (ISO228) 1/8", Seals in FPM, Orifice 1,2 mm, Coil 24V 50/60Hz (MI56, size 22).

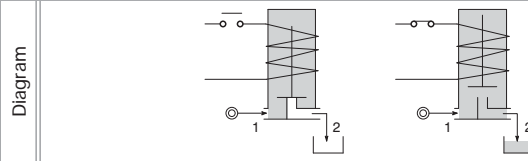

**Operational characteristic**

- Stainless Steel Body
- Guide pipe in Stainless Steel
- Mobile and fixed core in Stainless Steel
- Springs in Stainless Steel
- Sealing assemblies in FPM

**OPTIONS (if requested):**

- Advance ring in silver
- Coil for potentially explosive environments meeting 'ATEX standards Ex m Serie XME'.
- For use with oxygen

**Technical characteristic**

Maximum admitted pressure (bar)	50
Maximum fluid viscosity (mm <sup>2</sup> /s)	25cSt
Ambient temperature: with class F coil (°C)	-10 +55
Ambient temperature: with class H coil (°C)	-10 +80
Mounting position	indifferent
Weight (g.)	150

2-way normally closed diaphragm solenoid valve in stainless steel AISI 316, servo-actuated

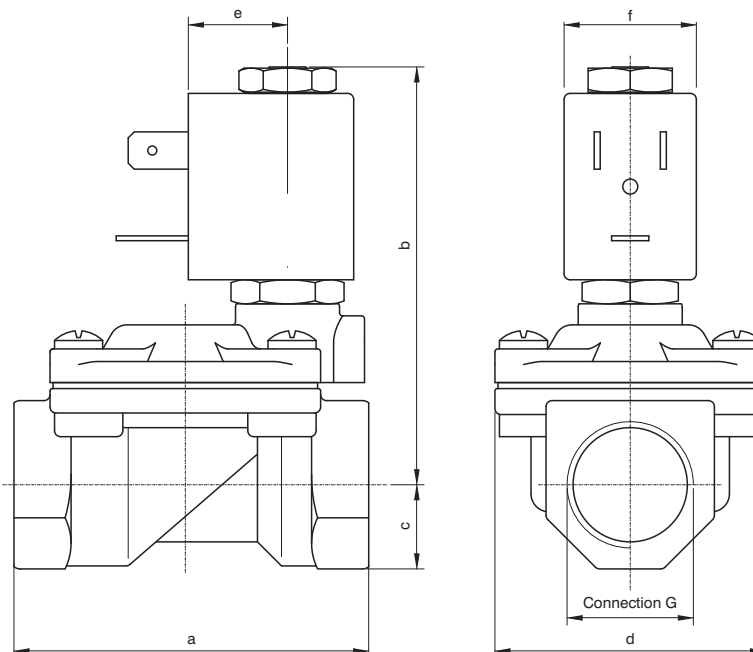

CONNECTION	a	b	c	d	e	f	Weight (gr.)
G3/8"	59	70	11	45	16	22	300
G1/2"	59	70	13	45	16	22	320
G3/4"	80	75	16	55	16	22	550
G1"	100	84	20	72	16	22	950

CODE "V"=Seals in FPM ⊕ = Coil	Connection G ISO 228	Orifice (mm)	KV (m³/h)	Differential pressure (bar)			Power Consumption			Coil ⊕		Temp. range (°C)
				Min	Max		AC Inrush	VA Holding	DC Watt	Series	Size	
					AC	DC						
F3177CV12⊕	3/8"	12	2,2	0,15	15	15	12	8	6,5	MI	22	-10 +140
F3177DV12⊕	1/2"	12	2,5	0,15	15	15	12	8	6,5	MI	22	
F3177EV18⊕	3/4"	18	5,5	0,15	13	13	12	8	6,5	MI	22	
F3177FV25⊕	1"	24	10,2	0,15	10	10	12	8	6,5	MI	22	

N.B. For use with steam maximum admitted pressure PS is 2.5 bar (relative pressure)

Example: F3177CV12b => F3177CV12MI5:

2-way normally closed diaphragm solenoid valve in stainless steel AISI 316, servo-actuated with Connector G (ISO228) 3/8", Seals in FPM, Orifice 12 mm, Coil 24V DC (MI5, size 22).

Pneumatic symbol

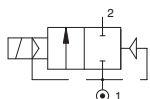

Diagram

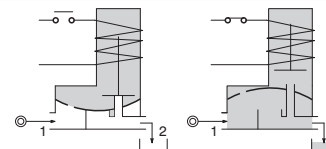

Operational characteristic

- Body and cover in Stainless Steel.
- Guide pipe in Stainless Steel
- Mobile and fixed core in Stainless Steel
- Springs in Stainless Steel
- Sealing assemblies in FPM

OPTIONS (if requested):

- Manual operation
- Coil for potentially explosive environments meeting 'ATEX standards Ex m Serie XME'.
- Seals for use with foodstuff fluids.
- Version with slowed commutation
- Version for use with oxygen
- Advance ring in silver

Technical characteristic

Minimum differential pressure (bar)	0,15
Maximum admitted pressure (bar)	25
Maximum fluid viscosity (mm <sup>2</sup> /s)	25cSt
Ambient temperature: with class F coil (°C)	-10 +55
Ambient temperature: with class H coil (°C)	-10 +80

Mounting position

Preferably with coil upwards



**Solenoid valves for fluids - F3206**  
**Brass body, with G connector (ISO228) 1/4"**

FLUID CONTROL

2-way normally open with direct operated plunger solenoid valve

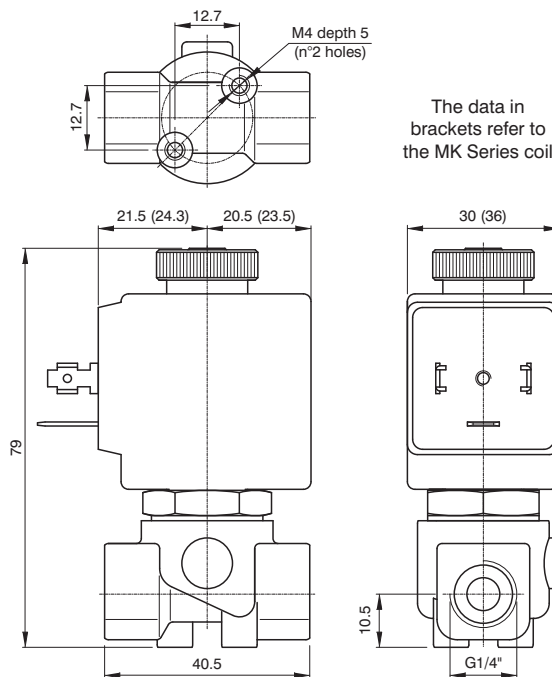

The data in brackets refer to the MK Series coil

CODE "V"=Seals in FPM ⊕ = Coil	Connection G ISO 228	Orifice (mm)	KV (m³/h)	Differential pressure (bar)			Power Consumption			Coil ⊕		Temp. range (°C)
				Min	Max		AC Inrush	VA Holding	DC Watt	Series	Size	
					AC	DC						
F3206BV15⊕	1/4"	1,5	0,07	0	23	-	20	15	-	MG	30	-10 +140
F3206BV20⊕	1/4"	2,0	0,1	0	17	-	20	15	-	MG	30	
F3206BV25⊕	1/4"	2,5	0,15	0	12	-	20	15	-	MG	30	
F3206BV35⊕	1/4"	3,5	0,32	0	7	-	20	15	-	MG	30	
F3206BV45⊕	1/4"	4,5	0,41	0	4,5	-	20	15	-	MG	30	
F3206BV52⊕	1/4"	5,2	0,47	0	3	-	20	15	-	MG	30	
F3206BV15⊕	1/4"	1,5	0,07	0	23	23	20	15	-	MK	36	
F3206BV20⊕	1/4"	2,0	0,1	0	17	17	40	30	27	MK	36	
F3206BV25⊕	1/4"	2,5	0,15	0	12	12	40	30	27	MK	36	
F3206BV35⊕	1/4"	3,5	0,32	0	7	7	40	30	27	MK	36	
F3206BV45⊕	1/4"	4,5	0,41	0	4,5	4,5	40	30	27	MK	36	
F3206BV52⊕	1/4"	5,2	0,47	0	3	3	40	30	27	MK	36	
F3206BV64⊕	1/4"	6,4	0,64	0	3,5	3,5	40	30	27	MK	36	

N.B. For use with steam maximum admitted pressure PS is 2.5 bar (relative pressure)

Example: F3206BV15b => F3206BV15MG58:

2-way normally open with direct operated plunger solenoid valve with Connector G (ISO228) 1/4", Seals in FPM, Orifice 1.5 mm, Coil 220V 50/60Hz (MG58, size 30).

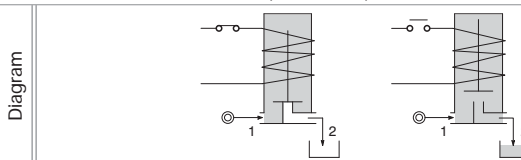
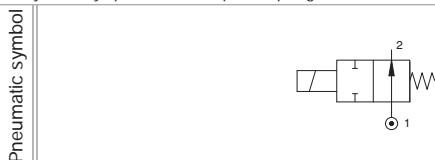

**Operational characteristic**

- Brass Body.
- Guide pipe in Brass.
- Mobile and fixed core in Stainless Steel
- Springs in Stainless Steel
- Sealing assemblies in FPM
- **OPTIONS (if requested):**
- Surface treatment in chemical nickel-plating
- Guide pipe in Stainless Steel

**Technical characteristic**

Maximum admitted pressure (bar)	50
Maximum fluid viscosity (mm <sup>2</sup> /s)	25cSt
Ambient temperature: with class F coil (°C)	-10 +55
Ambient temperature: with class H coil (°C)	-10 +80
Mounting position	indifferent
Weight (gr.) with MG Series Coil	300
Weight (gr.) with MK Series Coil	380

2-way normally open with direct operated plunger solenoid valve

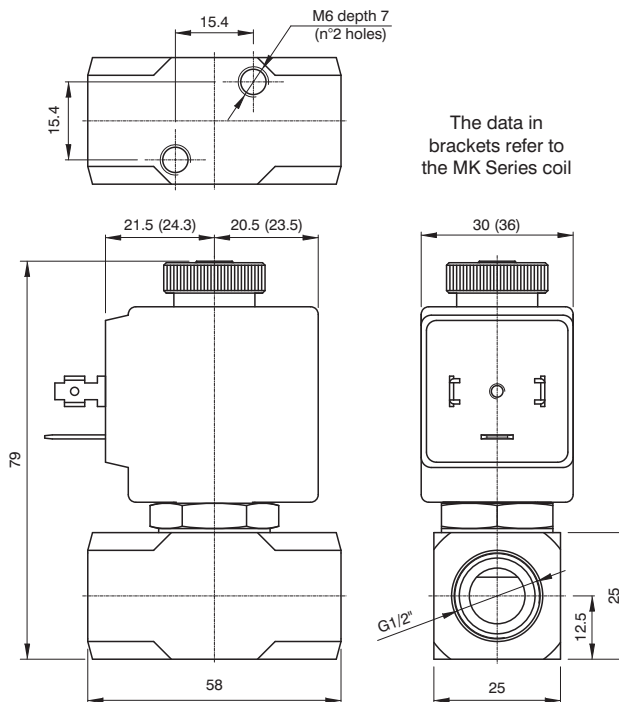

CODE "V"=Seals in FPM ⊕ = Coil	Connection G ISO 228	Orifice (mm)	KV (m <sup>3</sup> /h)	Differential pressure (bar)			Power Consumption			Coil ⊕		Temp. range (°C)
				Min	Max		AC Inrush	VA Holding	DC Watt	Series	Size	
					AC	DC						
F3206DV52⊕	1/2"	5,2	0,47	0	3	-	20	15	-	MG	30	-10 +140
F3206DV52⊕	1/2"	5,2	0,47	0	3	3	40	30	27	MK	36	
F3206DV64⊕	1/2"	6,4	0,64	0	3,5	3,5	40	30	27	MK	36	

N.B. For use with steam maximum admitted pressure PS is 2.5 bar (relative pressure)

Example: F3206DV30b => F3206DV30MG58:

2-way normally open with direct operated plunger solenoid valve with Connector G (ISO228) 1/2", Seals in FPM, Orifice 3 mm, Coil) 220V 50/60Hz (MG58, size 30).

Pneumatic symbol

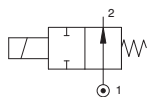

Diagram

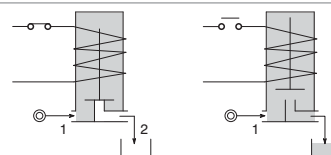

**Operational characteristic**

- Brass Body.
  - Guide pipe in Brass.
  - Mobile and fixed core in Stainless Steel
  - Springs in Stainless Steel
  - Sealing assemblies in FPM
- OPTIONS (if requested):**
- Surface treatment in chemical nickel-plating
  - Guide pipe in Stainless Steel

**Technical characteristic**

Maximum admitted pressure (bar)	50
Maximum fluid viscosity (mm <sup>2</sup> /s)	25cSt
Ambient temperature: with class F coil (°C)	-10 +55
Ambient temperature: with class H coil (°C)	-10 +80
Mounting position	indifferent
Weight (gr.) with MG Series Coil	360
Weight (gr.) with MK Series Coil	440

2-way normally open servo-actuated diaphragm solenoid valve

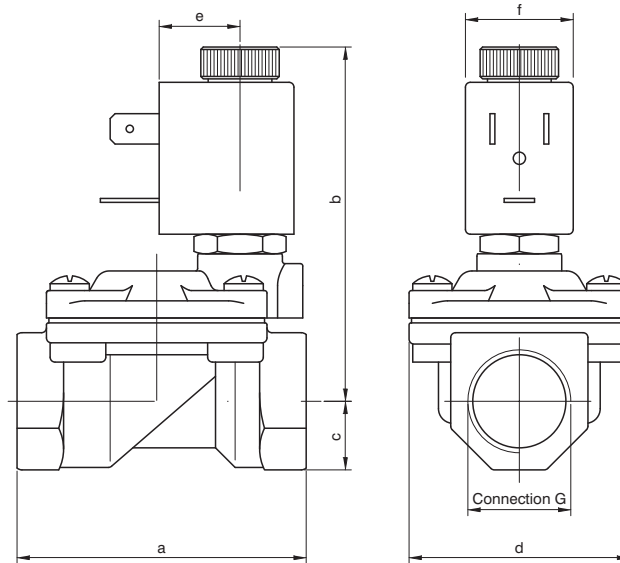

CONNECTION	a	b	c	d	e	f	Weight (gr.)
G1/4" Ø10	49	69	11	32	16	22	230
G3/8" Ø10	49	69	11	32	16	22	240
G1/2" Ø12	59	74	14	45	16	22	390
G3/4"	79	81	18	55	16	22	650
G1"	96	89	20	72	16	22	1050

CODE "V" = Seals in FPM "E" = Coil	Connection G ISO 228	Orifice (mm)	KV (m³/h)	Differential pressure (bar)			Power Consumption			Coil "E"		Temp. range (°C)
				Min	Max		AC Inrush	VA Holding	DC Watt	Series	Size	
					AC	DC						
F3207BV10E	1/4"	10	1,5	0,15	15	15	12	8	6,5	MI	22	-10 +140
F3207CV10E	3/8"	10	1,7	0,15	15	15	12	8	6,5	MI	22	
F3207DV12E	1/2"	12	2,5	0,15	15	15	12	8	6,5	MI	22	
F3207EV18E	3/4"	18	5,5	0,15	13	13	12	8	6,5	MI	22	
F3207FV25E	1"	24	10,2	0,15	10	10	12	8	6,5	MI	22	

N.B. For use with steam maximum admitted pressure PS is 2.5 bar (relative pressure)

Example: F3207BV10b => F3207BV10MI5

2-way normally open servo-actuated diaphragm solenoid valve with Connector G (ISO228) 1/4", Seals in FPM, Orifice 10 mm, Coil 24V DC (MI5, size 22).

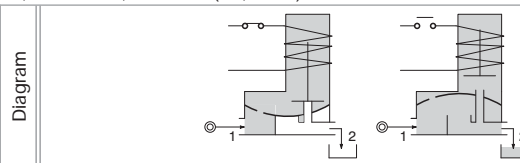

Operational characteristic

- Body and cover in Brass
- Guide pipe in Stainless Steel
- Mobile and fixed core in Stainless Steel
- Springs in Stainless Steel
- Sealing assemblies in FPM
- **OPTIONS (if requested):**
- Surface treatment in chemical nickel-plating
- Coil for potentially explosive environments meeting 'ATEX standards Ex m Serie XME'.

Technical characteristic

Minimum differential pressure (bar)	0,15
Maximum admitted pressure (bar)	25
Maximum fluid viscosity (mm <sup>2</sup> /s)	25cSt
Ambient temperature: with class F coil (°C)	-10 +55
Ambient temperature: with class H coil (°C)	-10 +80
Mounting position	indifferent

2-way normally open with direct operated plunger solenoid valve

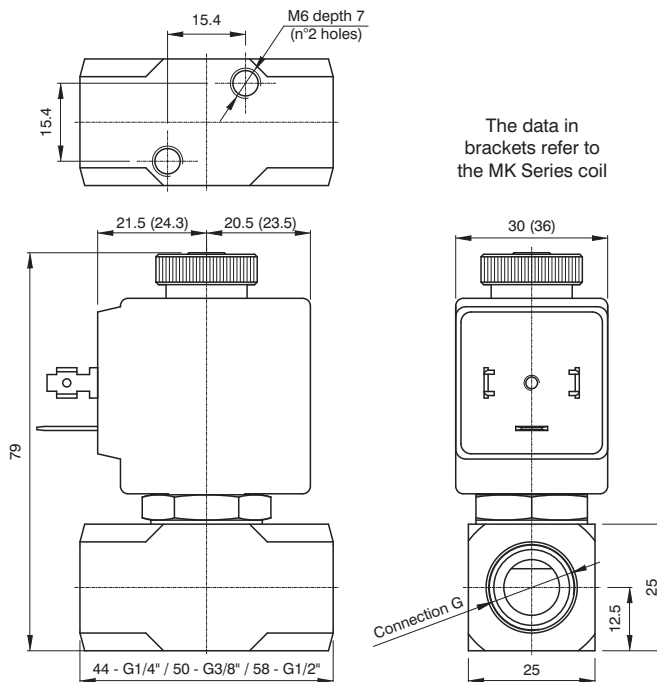

CODE "V"=Seals in FPM ⊕ = Coil	Connection G ISO 228	Orifice (mm)	KV (m <sup>3</sup> /h)	Differential pressure (bar)			Power Consumption			Coil ⊕		Temp. range (°C)
				Min	Max		AC Inrush	VA Holding	DC Watt	Series	Size	
					AC	DC						
F3210BV25⊕	1/4"	2,5	0,15	0	10	-	20	15	-	MG	30	-10 +140
F3210BV35⊕	1/4"	3,5	0,32	0	7	-	20	15	-	MG	30	
F3210BV45⊕	1/4"	4,5	0,41	0	4,5	-	20	15	-	MG	30	
F3210CV35⊕	3/8"	3,5	0,32	0	7	-	20	15	-	MG	30	
F3210CV52⊕	3/8"	5,2	0,47	0	3	-	20	15	-	MG	30	
F3210DV35⊕	1/2"	3,5	0,32	0	7	-	20	15	-	MG	30	
F3210DV52⊕	1/2"	5,2	0,47	0	3	-	20	15	-	MG	30	
F3210BV25⊕	1/4"	2,5	0,15	0	10	10	40	30	27	MK	36	
F3210BV35⊕	1/4"	3,5	0,32	0	7	7	40	30	27	MK	36	
F3210BV45⊕	1/4"	4,5	0,41	0	4,5	4,5	40	30	27	MK	36	
F3210CV35⊕	3/8"	3,5	0,32	0	7	7	40	30	27	MK	36	
F3210CV52⊕	3/8"	5,2	0,47	0	3	3	40	30	27	MK	36	
F3210DV35⊕	1/2"	3,5	0,32	0	7	7	40	30	27	MK	36	
F3210DV52⊕	1/2"	5,2	0,47	0	3	3	40	30	27	MK	36	
F3210DV64⊕	1/2"	6,4	0,64	0	3,5	3,5	40	30	27	MK	36	

N.B. For use with steam maximum admitted pressure PS is 2.5 bar (relative pressure)

Example: F3210BV25b => F3210BV25MG56: 2-way normally open with direct operated plunger solenoid valve with Connector G (ISO228) 1/4", Seals in FPM, Orifice 2,5 mm, Coil 24V 50/60Hz (MG56, size 30).

Pneumatic symbol

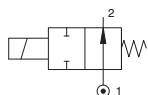

Diagram

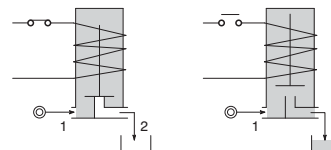

**Operational characteristic**

- Stainless Steel Body
- Guide pipe in Stainless Steel
- Mobile and fixed core in Stainless Steel
- Springs in Stainless Steel
- Sealing assemblies in FPM
- **OPTIONS (if requested):**
- Advance ring in silver

**Technical characteristic**

Maximum admitted pressure (bar)	50
Maximum fluid viscosity (mm <sup>2</sup> /s)	25cSt
Ambient temperature: with class F coil (°C)	-10 +55
Ambient temperature: with class H coil (°C)	-10 +80
Mounting position	indifferent



**Solenoid valves for fluids - F3211**  
**Stainless Steel Body, with Connector G (ISO228) 1/8"**

FLUID CONTROL

2-way normally open with direct operated plunger solenoid valve

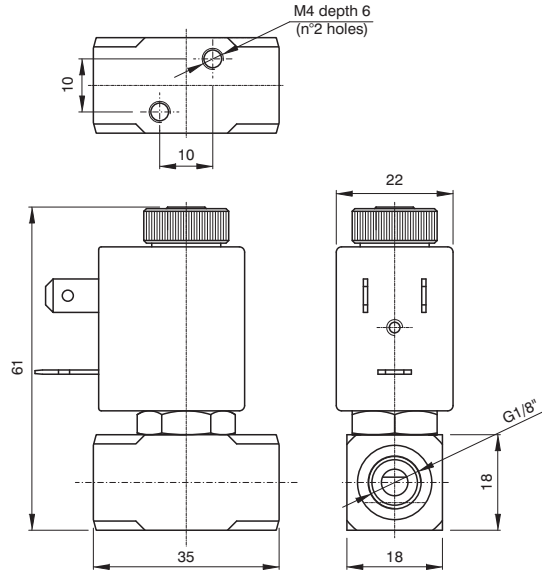

CODE "V" = Seals in FPM ⊕ = Coil	Connection G ISO 228	Orifice (mm)	KV (m³/h)	Differential pressure (bar)			Power Consumption			Coil ⊕		Temp. range (°C)
				Min	Max		AC Inrush	VA Holding	DC Watt	Series	Size	
					AC	DC						
F3211AV12⊕	1/8"	1,2	0,04	0	19	19	12	8	6,5	MI	22	-10 +140
F3211AV15⊕	1/8"	1,5	0,06	0	14	14	12	8	6,5	MI	22	
F3211AV20⊕	1/8"	2	0,09	0	8	8	12	8	6,5	MI	22	

N.B. For use with steam maximum admitted pressure PS is 2.5 bar (relative pressure)

Example: F3211AV12b => F3211AV12MI56:

2-way normally open with direct operated plunger solenoid valve with Connector G (ISO228) 1/8", Seals in FPM, Orifice 1,2 mm, Coil 24V 50/60Hz (MI56, size 22).

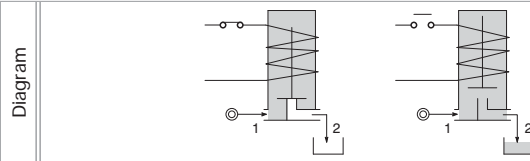

**Operational characteristic**

- Stainless Steel Body
- Guide pipe in Stainless Steel
- Mobile and fixed core in Stainless Steel
- Springs in Stainless Steel
- Sealing elements in FPM

- **OPTIONS (if requested):**
- Coil for potentially explosive environments meeting 'ATEX standards Ex m Serie XME'.

**Technical characteristic**

Maximum admitted pressure (bar)	50
Maximum fluid viscosity (mm <sup>2</sup> /s)	25cSt
Ambient temperature: with class F coil (°C)	-10 +55
Ambient temperature: with class H coil (°C)	-10 +80
Mounting position	indifferent

2-way normally open servo-actuated diaphragm solenoid valve in stainless steel AISI 316

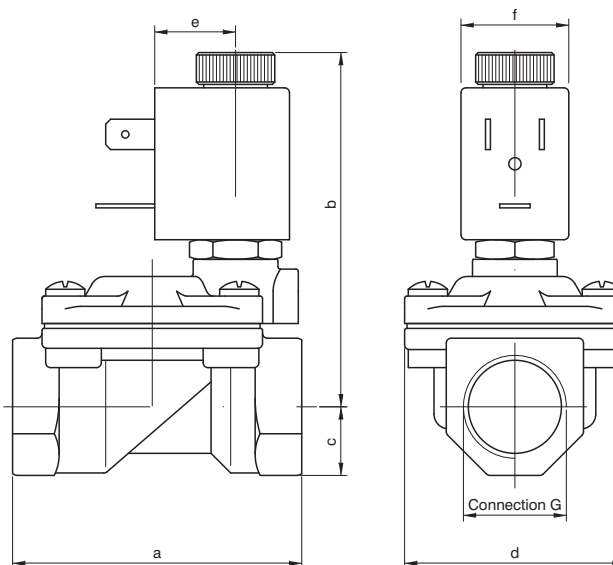

CONNECTION	a	b	c	d	e	f	Weight (gr.)
G3/8"	59	74	11	45	16	22	300
G1/2"	59	74	13	45	16	22	320
G3/4"	80	78	16	55	16	22	550
G1"	100	88	20	72	16	22	1350

CODE "V"=Seals in FPM "E" = Coil	Connection G ISO 228	Orifice (mm)	KV (m³/h)	Differential pressure (bar)			Power Consumption			Coil "E"		Temp. range (°C)
				Min	Max		AC Inrush	VA Holding	DC Watt	Series	Size	
					AC	DC						
F3277CV12E	3/8"	12	2,2	0,15	15	15	12	8	6,5	MI	22	-10 +140
F3277DV12E	1/2"	12	2,5	0,15	15	15	12	8	6,5	MI	22	
F3277EV18E	3/4"	18	5,5	0,15	13	13	12	8	6,5	MI	22	
F3277FV25E	1"	24	10,2	0,15	10	10	12	8	6,5	MI	22	

N.B. For use with steam maximum admitted pressure PS is 2.5 bar (relative pressure)

Example: F3277CV12b => F3277CV12MI5:

2-way normally open servo-actuated diaphragm solenoid valve in stainless steel AISI 316 with Connector G (ISO228) 3/8", Seals in FPM, Orifice 12 mm, Coil 24V DC (MI5, size 22).

Pneumatic symbol

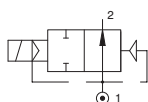

Diagram

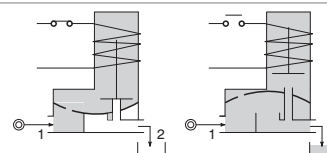

Operational characteristic

- Body and cover in Stainless Steel.
- Guide pipe in Stainless Steel
- Mobile and fixed core in Stainless Steel
- Springs in Stainless Steel
- Sealing assemblies in FPM
- **OPTIONS (if requested):**
- Coil for potentially explosive environments meeting 'ATEX standards Ex m Serie XME'.
- Seals for use with foodstuff fluids.
- Advance ring in silver

Technical characteristic

Minimum differential pressure (bar)	0,15
Maximum admitted pressure (bar)	25
Maximum fluid viscosity (mm <sup>2</sup> /s)	25cSt
Ambient temperature: with class F coil (°C)	-10 +55
Ambient temperature: with class H coil (°C)	-10 +80
Mounting position	Preferably with coil upwards



**Solenoid valves for fluids - F3310**  
**Stainless Steel Body, with Connector G (ISO228) 1/4"**

FLUID CONTROL

3-way direct acting solenoid valve

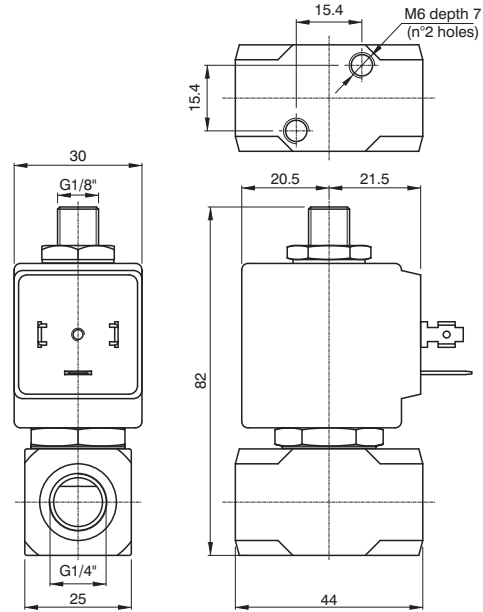

CODE "V"=Seals in FPM "E" = Coil	Connection <b>G</b> ISO 228	Orifice (mm) Inlet   Exhaust		KV (m <sup>3</sup> /h)	Differential pressure (bar)			Power Consumption			Coil <b>E</b>		Temp. range (°C)
					Min	Max		AC Inrush	VA Holding	DC Watt	Series	Size	
						AC	DC						
<b>U Universal</b>													
F3310BV25U <b>E</b>	1/4"	2,5	2,4	0,16	0	5	4	20	15	10	MG	30	-10 +140

Example: F3310BV25Gb => F3310BV25GMG5:  
 3-way direct acting solenoid valve with Connector G (ISO228) 1/4", Seals in FPM, Feed bore 2,5 mm, Exhaust bore 2,4 mm Coil 24V DC (MG5, size 30), N.O.

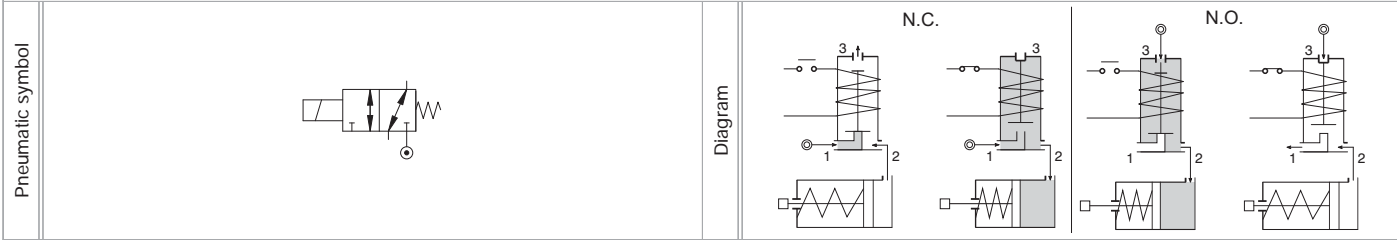

Operational characteristic	Technical characteristic	
<ul style="list-style-type: none"> <li>- Stainless Steel Body</li> <li>- Guide pipe in Stainless Steel</li> <li>- Mobile and fixed core in Stainless Steel</li> <li>- Springs in Stainless Steel</li> <li>- Sealing assemblies in FPM</li> </ul>	Maximum admitted pressure (bar)	Maximum running pressure + 10%
	Maximum fluid viscosity (mm <sup>2</sup> /s)	25cSt
	Ambient temperature: with class F coil (°C)	-10 +55
	Ambient temperature: with class H coil (°C)	-10 +80
<ul style="list-style-type: none"> <li>- <b>OPTIONS (if requested):</b></li> <li>- Advance ring in silver</li> </ul>	Mounting position	indifferent
	Weight (g.)	360

3-way direct acting solenoid valve

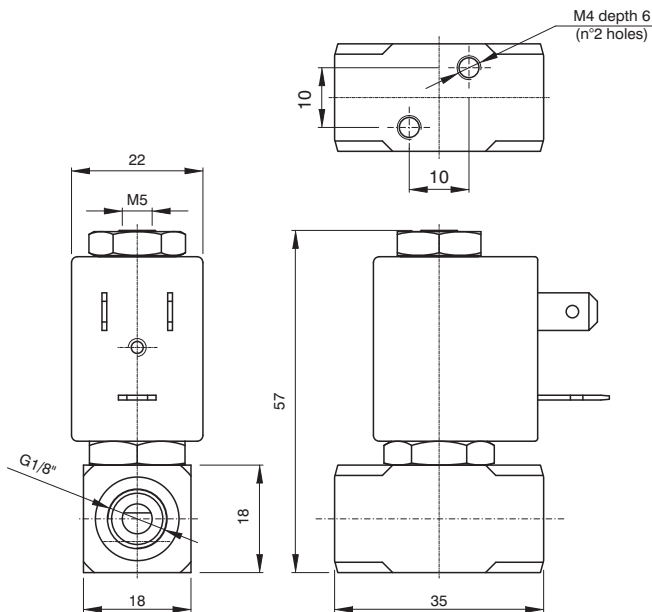

CODE "V"=Seals in FPM ⊕ = Coil	Connection G ISO 228	Orifice (mm)		KV (m <sup>3</sup> /h)	Differential pressure (bar)			Power Consumption			Coil ⊕		Temp. range (°C)
		Inlet	Exhaust		Min	Max		AC Inrush	VA Holding	DC Watt	Series	Size	
						AC	DC						
<b>U Universal</b>													
F3311AV15U⊕	1/8"	1,5	1,5	0,06	0	6	6	12	8	6,5	MI	22	-10 +140

Example: F3311AV15Gb => F3311AV15GMI5:

3-way direct acting solenoid valve with Connector G (ISO228) 1/8", Seals in FPM, Feed bore 1,5 mm, Exhaust bore 1,5 mm Coil 24V DC (MI5, size 22), N.O.

Pneumatic symbol

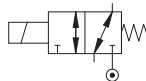

Diagram

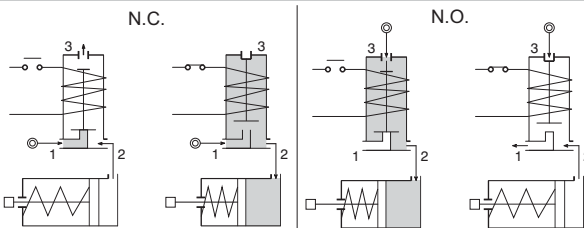

Operational characteristic

- Stainless Steel Body
- Guide pipe in Stainless Steel
- Mobile and fixed core in Stainless Steel
- Springs in Stainless Steel
- Sealing assemblies in FPM

OPTIONS (if requested):

- Advance ring in silver
- Coil for potentially explosive environments meeting 'ATEX standards Ex m Serie XME'.
- Exhaust with hose mount.

Technical characteristic

Maximum admitted pressure (bar)	Maximum running pressure + 10%
Maximum fluid viscosity (mm <sup>2</sup> /s)	25cSt
Ambient temperature: with class F coil (°C)	-10 +55
Ambient temperature: with class H coil (°C)	-10 +80
Mounting position	indifferent
Weight (g.)	150



**Solenoid valves for fluids - F3108**  
**Brass body, with G connector (ISO228) 3/8" - 1"**

2-way normally closed servo-actuated towed membrane solenoid valve

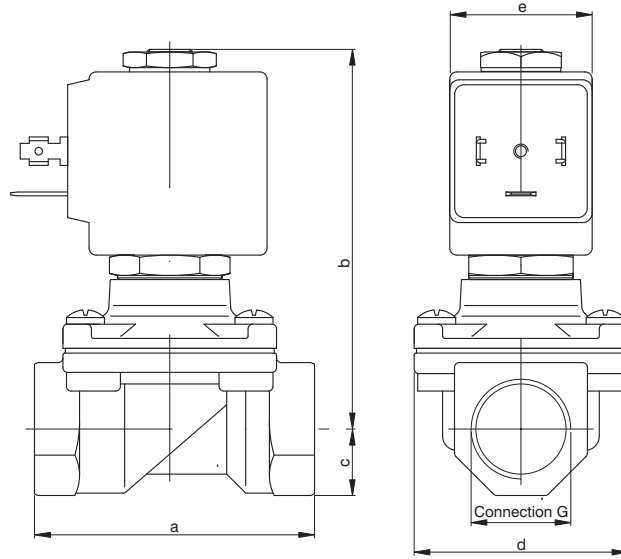

CONNECTION	a	b	c	d	e	f	Weight (g.) size 2	Weight (g.) size 5
G3/8" Ø12	59	83	14	45	16	36	0,50	0,58
G1/2"	59	83	14	45	16	36	0,45	0,53
G3/4"	79	90	18	55		36	-	0,75
G1"	96	101	20	72		36	-	1,10

CODE "V"=Seals in FPM ⊕ = Coil	Connection G ISO 228	Orifice (mm)	KV (m³/h)	Differential pressure (bar)			Power Consumption			Coil ⊕		Temp. range (°C)
				Min	Max		AC Inrush	VA Holding	DC Watt	Series	Size	
					AC	DC						
F3108CV12⊕	3/8"	12	2	0	10	-	20	15	-	MG	30	-10 +140
F3108DV12⊕	1/2"	12	2.2	0	10	-	20	15	-	MG	30	
F3108CV12⊕	3/8"	12	2	0	12	10	40	30	27	MK	36	
F3108DV12⊕	1/2"	12	2.2	0	12	10	40	30	27	MK	36	
F3108EV18⊕	3/4"	18	4.5	0	9	-	40	30	-	MK	36	
F3108FV25⊕	1"	24	8.5	0	7	-	40	30	-	MK	36	
F3108EV18C⊕	3/4"	18	4.5	0	-	9	-	-	27	MK	36	
F3108FV25C⊕	1"	24	8.5	0	-	8	-	-	27	MK	36	

Example: F3108DV12b => F3108DV12MG5:

2-way normally closed in brass with towed membrane solenoid valve with Connector G (ISO228) 1/2", Seals in FPM, Orifice 12 mm, Coil 24V DC (MG5, size 30).

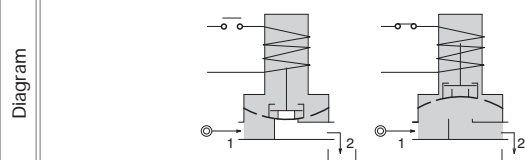

**Operational characteristic**

- Body and cover in Brass
- Guide pipe in Stainless Steel
- Mobile and fixed core in Stainless Steel
- Springs in Stainless Steel
- Sealing assemblies in FPM
- **OPTIONS (if requested):**
- Surface treatment in chemical nickel-plating

**Technical characteristic**

Maximum admitted pressure (bar)	25
Maximum fluid viscosity (mm <sup>2</sup> /s)	25cSt
Ambient temperature: with class F coil (°C)	-10 +55
Ambient temperature: with class H coil (°C)	-10 +80
Mounting position	Preferably with coil upwards

2-way normally closed servo-actuated piston solenoid valve 1/4"

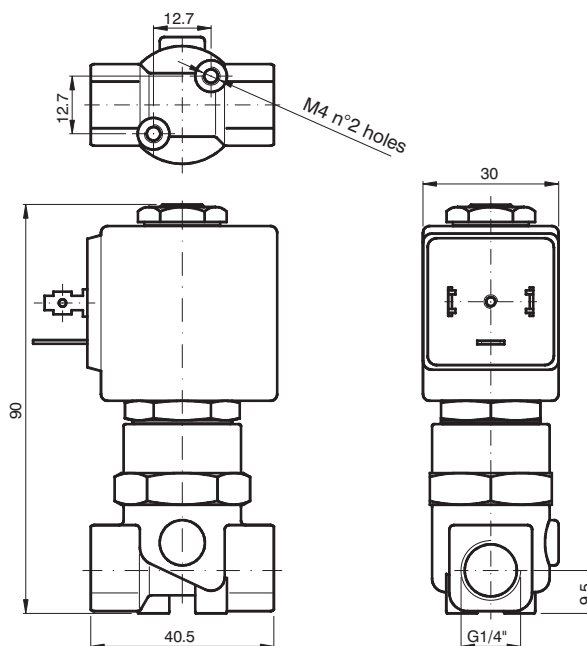

CODE "V"=Seals in FPM ⊕ = Coil	Connection G ISO 228	Orifice (mm)	KV (m <sup>3</sup> /h)	Differential pressure (bar)			Power Consumption			Coil ⊕		Temp. range (°C)
				Min	Max		AC Inrush	VA Holding	DC Watt	Series	Size	
					AC	DC						
F3119BV52⊕	1/4"	5,2	0,47	1,5	50	50	20	15	10	MG	30	-10 +140

Example: F3119BV52b => F3119BV52MG5:

2-way normally closed servo-actuated piston solenoid valve in brass with Connector G (ISO228) 1/4", Seals in FPM, Orifice 5,2 mm, Coil 24V DC (MG5, size 30).

Pneumatic symbol

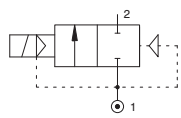

Diagram

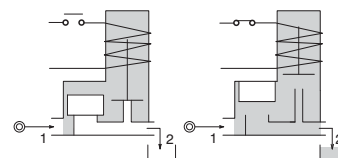

Operational characteristic

- Body and cover in Brass
- Guide pipe in Stainless Steel
- Mobile and fixed core in Stainless Steel
- Springs in Stainless Steel
- Piston in Brass.
- Guide slide in loaded PTFE.
- Main shutter in PTFE.
- Remaining sealing elements in FPM.
- **OPTIONS (if requested):**
- Surface treatment in chemical nickel-plating

Technical characteristic

Minimum differential pressure (bar)	1
Maximum admitted pressure (bar)	40
Maximum running pressure Version /1 (bar)	60
Maximum fluid viscosity (mm <sup>2</sup> /s)	25cSt
Ambient temperature: with class F coil (°C)	-10 +55
Ambient temperature: with class H coil (°C)	-10 +80
Mounting position	Preferably with coil upwards
Weight (g.)	630



**Solenoid valves for fluids - F3119**  
**Brass body, with G connector (ISO228) 3/8" - 1/2"**

FLUID CONTROL

2-way normally closed, servo-actuated piston solenoid valve

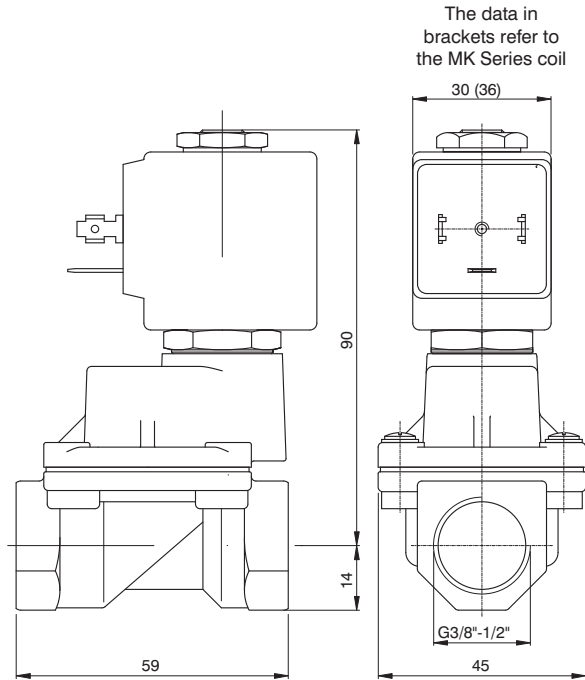

CODE "V" = Seals in FPM ⊕ = Coil	Connection G ISO 228	Orifice (mm)	KV (m³/h)	Differential pressure (bar)			Power Consumption			Coil ⊕		Temp. range (°C)
				Min	Max		AC Inrush	VA Holding	DC Watt	Series	Size	
					AC	DC						
F3119CV12⊕	3/8"	12	2	1	30	30	20	15	10	MG	30	-10 +140
F3119DV12⊕	1/2"	12	2.2	1	30	30	20	15	10	MG	30	
F3119CV12/1⊕	3/8"	12	2	1	50	30	40	30	27	MK	36	
F3119DV12/1⊕	1/2"	12	2.2	1	50	30	40	30	27	MK	36	

Example: F3119DV12b => F3108DV12MG5:  
 2-way normally closed servo-actuated piston solenoid valve in brass with Connector G (ISO228) 1/2", Seals in FPM, Orifice 12 mm, Coil 24V DC (MG5, size 30).

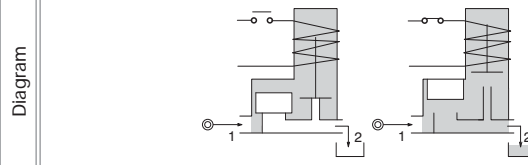
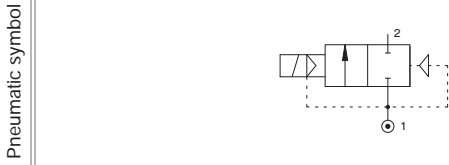

**Operational characteristic**

- Body and cover in Brass
- Guide pipe in Stainless Steel
- Mobile and fixed core in Stainless Steel
- Springs in Stainless Steel
- Piston in Brass.
- Guide slide in loaded PTFE.
- Main shutter in PTFE.
- Remaining sealing elements in FPM..
- **OPTIONS (if requested):**
- Surface treatment in chemical nickel-plating

**Technical characteristic**

Minimum differential pressure (bar)	1
Maximum admitted pressure (bar)	40
Maximum running pressure Version /1 (bar)	60
Maximum fluid viscosity (mm <sup>2</sup> /s)	25cSt
Ambient temperature: with class F coil (°C)	-10 +55
Ambient temperature: with class H coil (°C)	-10 +80
Mounting position	Preferably with coil upwards
Weight (gr.) with MG Series Coil	630
Weight (gr.) with MK Series Coil	710

2-way normally closed servo-actuated piston solenoid valve for use with steam

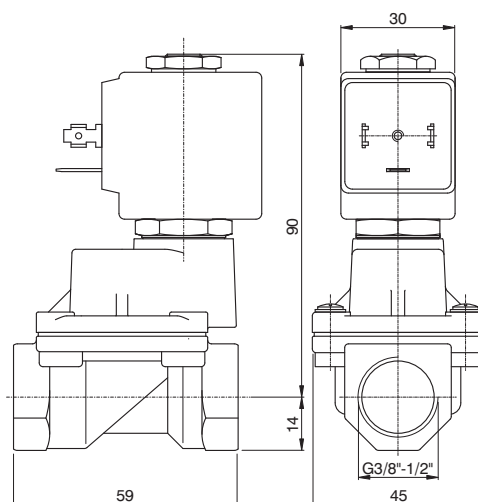

CODE "V"=Seals in FPM "E" = Coil	Connection G ISO 228	Orifice (mm)	KV (m <sup>3</sup> /h)	Differential pressure (bar)			Power Consumption			Coil "E"		Temp. range (°C)
				Min	Max		AC Inrush	VA Holding	DC Watt	Series	Size	
					AC	DC						
F3119CW12/1E	3/8"	12	2	2,5	9	9	20	15	10	MG	30	-10 +180
F3119DW12/1E	1/2"	12	2.2	2,5	9	9	20	15	10	MG	30	

Example: F3119DW12/1b => F3119DW12/1MG5:

2-way normally closed servo-actuated piston solenoid valve in brass with Connector G (ISO228) 1/2", Seals in FPM, Orifice 12 mm, Coil 24V DC (MG5, size 30).

Pneumatic symbol

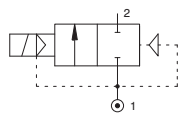

Diagram

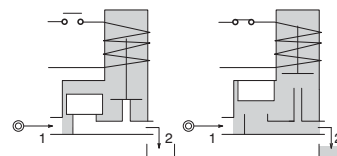

Operational characteristic

- Body and cover in Brass
- Guide pipe in Stainless Steel
- Mobile and fixed core in Stainless Steel
- Springs in Stainless Steel
- Piston in Stainless Steel.
- Guide slide in loaded PTFE.
- Sealing elements in PFTE/FPM.
- **OPTIONS (if requested):**
- Surface treatment in chemical nickel-plating
- Steam sealing up to +160°C

Technical characteristic

Minimum differential pressure (bar)	2,5
Ambient temperature: only with class H Coil (°C)	-10 +80
Mounting position	Preferably with coil upwards
Weight (g.)	630



**Solenoid valves for fluids - FX3106**  
**Brass body, with G connector (ISO228) 1/4"**

FLUID CONTROL

2-way solenoid normally closed valve, direct plunger operation, with housing for potentially explosive environments certified: CESI 03 ATEX 344 ExII2G/D Eex "d" IIC T6

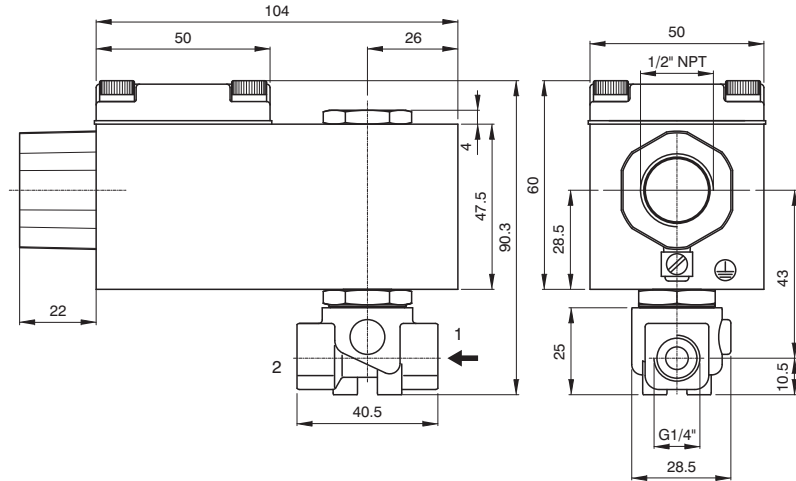

CODE "V"=Seals in FPM ⊕ = Coil	Connection G ISO 228	Orifice (mm)	KV (m³/h)	Differential pressure (bar)			Power Consumption		Temp. range (°C)
				Min	Max		AC Inrush	DC Watt	
					AC	DC			
FX3106BV35⊕	1/4"	3,5	0,32	0	10	8	12	8	-10 +140
FX3106BV45⊕	1/4"	4,5	0,41	0	6,5	3,5	12	8	

  

Coil ⊕ A6 Series (CURRENT)	
A6B=24 Volt (AC 50/60Hz)	
A6E=220/230 Volt (AC 50/60Hz)	
A60=24 Volt (DC)	
A61=12 Volt (DC)	

N.B. The solenoid valve is suited for intercepting only fluids that are NOT potentially explosive.

Example: FX3106BV35b => FX3106BV35A60:

2-way solenoid normally closed valve, direct plunger operation, with housing for potentially explosive environments certified: CESI 03 ATEX 344 ExII2G/D Eex "d" IIC T6, with Connector G (ISO228) 1/4", Seals in FPM, Orifice 3,5 mm, Coil 24V DC (A60).

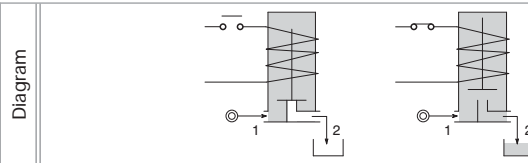
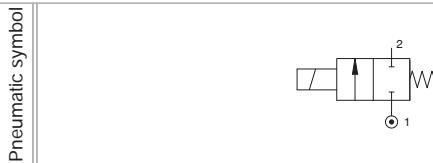

Operational characteristic	Technical characteristic	
<ul style="list-style-type: none"> <li>- Brass Body</li> <li>- Container in light red coloured alloy</li> <li>- Electrical connection 1/2" NPT</li> <li>- Sealing elements in FPM</li> </ul>	Maximum admitted pressure (bar)	80
	Maximum fluid viscosity (mm <sup>2</sup> /s)	25cSt
	Ambient temperature (°C)	-10 +40
	Mounting position	with coil upwards
	Weight (g.)	600

2-way normally closed direct acting solenoid valve with housing for potentially explosive environments certified: CESI 03 ATEX 344 ExII2G/D Eex "d" IIC T6

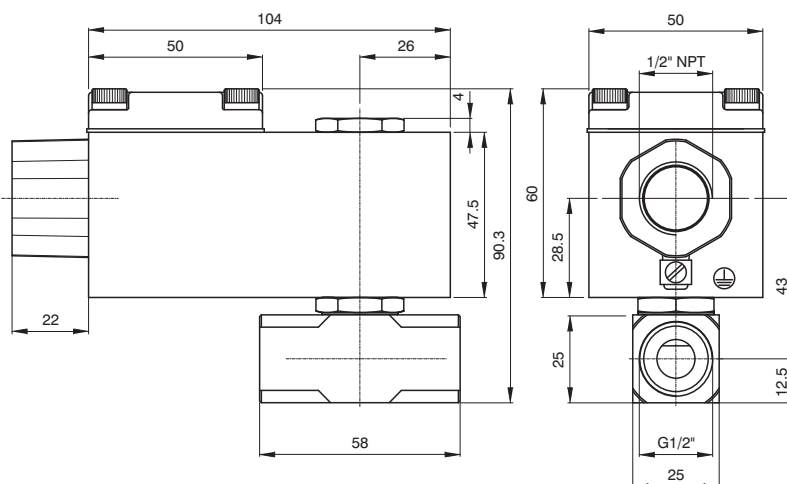

CODE "V"=Seals in FPM ⊕ = Coil	Connection G ISO 228	Orifice (mm)	KV (m <sup>3</sup> /h)	Differential pressure (bar)			Power Consumption		Temp. range (°C)
				Min	Max		AC Inrush	DC Watt	
					AC	DC			
FX3106DV52⊕	1/2"	5,2	0,47	0	4	1,8	12	8	-10 +140
FX3106DV64⊕	1/2"	6,4	0,64	0	3	1	12	8	

Coil ⊕ A6 Series (CURRENT)	
A6B=24 Volt (AC 50/60Hz)	
A6E=220/230 Volt (AC 50/60Hz)	
A6O=24 Volt (DC)	
A6I=12 Volt (DC)	

N.B. The solenoid valve is suited for intercepting only fluids that are NOT potentially explosive.

Example: FX3106DV52b => FX3106DV52A60:

2-way solenoid normally closed valve, direct plunger operation, with housing for potentially explosive environments certified: CESI 03 ATEX 344 ExII2G/D Eex "d" IIC T6, with Connector G (ISO228) 1/2", Seals in FPM, Orifice 5,2 mm, Coil 24V DC (A60).

Pneumatic symbol

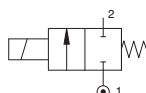

Diagram

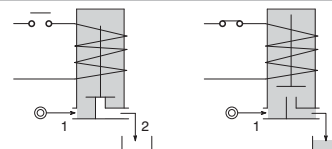

**Operational characteristic**

- Brass Body
- Container in light red coloured alloy
- Electrical connection 1/2" NPT
- Sealing elements in FPM
- **OPTIONS (if requested):**
- Manual operation
- Surface treatment in chemical nickel-plating
- Inserted stainless steel seating

**Technical characteristic**

Maximum admitted pressure (bar)	80
Maximum fluid viscosity (mm <sup>2</sup> /s)	25cSt
Ambient temperature (°C)	-10 + 40
Mounting position	with coil upwards
Weight (g.)	660



**Solenoid valves for fluids - FX3107**  
**Body and cover in Brass, with Connector G (ISO228) 1/4" - 1"**

FLUID CONTROL

2-Way normally closed solenoid valve, servo-actuated diaphragm, with housing for potentially explosive environments certified: CESI 03 ATEX 344 ExII2G/D Eex "d" IIC T6

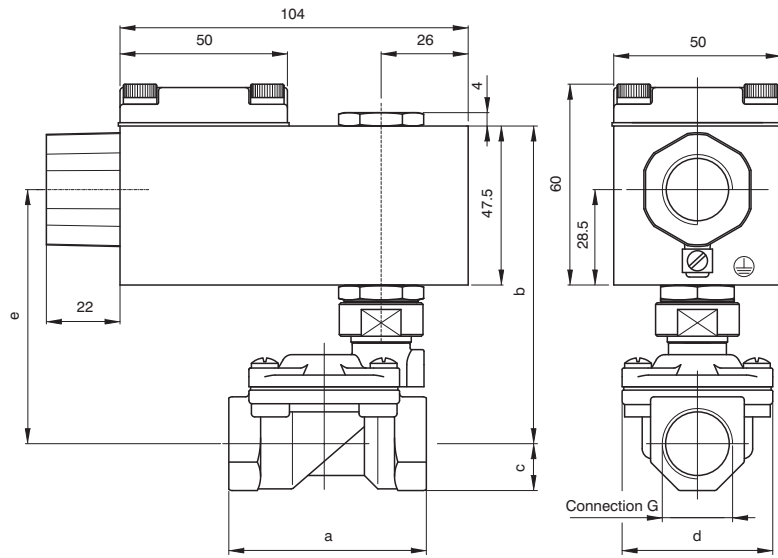

Connection G	a	b	c	d	e	Weight (g.)
G1/4" Ø10	49	90	11	32	71	720
G3/8" Ø12	59	95	14	45	76	920
G1/2" Ø12	59	95	14	45	76	920
G3/4"	79	101	18	54	82	1100
G1"	96	110	20	72	91	1500

CODE "V"=Seals in FPM ⊕ = Coil	Connection G ISO 228	Orifice (mm)	KV (m³/h)	Differential pressure (bar)			Power Consumption		Temp. range (°C)	Coil ⊕ A6 Series (CURRENT)
				Min	Max		AC Inrush	DC Watt		
					AC	DC				
FX3107BV10⊕	1/4"	10	1,5	0,15	15	15	12	8	-10 +140	A6B=24 Volt (AC 50/60Hz)
FX3107CV12⊕	3/8"	12	2,2	0,15	15	15	12	8		A6E=220/230 Volt (AC 50/60Hz)
FX3107DV12⊕	1/2"	12	2,5	0,15	15	15	12	8		A6B=24 Volt (DC)
FX3107EV18⊕	3/4"	18	5,5	0,15	13	13	12	8		A61=12 Volt (DC)
FX3107FV25⊕	1"	24	10,2	0,15	10	10	12	8		

N.B. The solenoid valve is suited for intercepting only fluids that are NOT potentially explosive.

Example: FX3107BV101b => FX3107BV101A60.

2-Way normally closed solenoid valve, servo-actuated diaphragm, with housing for potentially explosive environments certified: CESI 03 ATEX 344 ExII2G/D Eex "d" IIC T6, with Connector G (ISO228) 1/4", Seals in FPM, Orifice 10 mm, Coil 24V DC (A60).

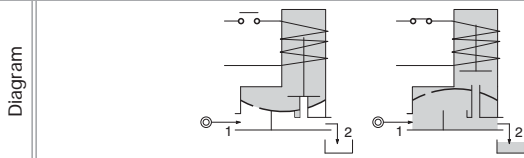

Operational characteristic	Technical characteristic	
<ul style="list-style-type: none"> <li>- Body and cover in Brass</li> <li>- Container in light red coloured alloy</li> <li>- Electrical connection 1/2" NPT</li> <li>- Sealing elements in FPM</li> <li>- <b>OPTIONS (if requested):</b></li> <li>- Surface treatment in chemical nickel-plating</li> <li>- Version with slowed commutation</li> </ul>	Minimum differential pressure (bar)	0,15
	Maximum admitted pressure (bar)	25
	Maximum fluid viscosity (mm <sup>2</sup> /s)	25cSt
	Ambient temperature (°C)	-10 +40
	Mounting position	Preferably with coil upwards

2-Way normally closed direct acting solenoid valve with housing for potentially explosive environments certified: CESI 03 ATEX 344 ExII2G/D Eex "d" IIC T6

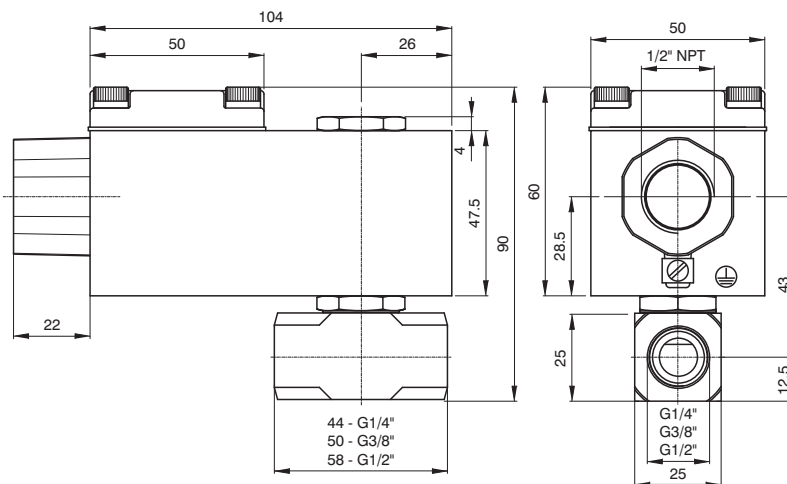
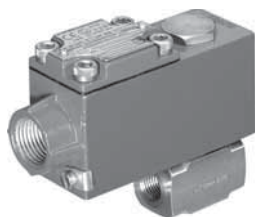

CODE "V" = Seals in FPM ⊕ = Coil	Connection G ISO 228	Orifice (mm)	KV (m <sup>3</sup> /h)	Differential pressure (bar)		Power Consumption		Temp. range (°C)	Coil ⊕ A6 Series (CURRENT)
				Min	Max	AC Inrush	DC Watt		
FX3110BV25⊕	1/4"	2,5	0,15	0	16	14	12	8	-10 +140  A6B=24 Volt (AC 50/60Hz) A6E=220/230 Volt (AC 50/60Hz) A60=24 Volt (DC) A61=12 Volt (DC)
FX3110BV35⊕	1/4"	3,5	0,32	0	10	8	12	8	
FX3110BV45⊕	1/4"	4,5	0,41	0	6,5	3,5	12	8	
FX3110CV35⊕	3/8"	3,5	0,32	0	10	8	12	8	
FX3110CV52⊕	3/8"	5,2	0,47	0	4	1,8	12	8	
FX3110DV35⊕	1/2"	3,5	0,32	0	10	8	12	8	
FX3110DV52⊕	1/2"	5,2	0,47	0	4	1,8	12	8	
FX3110DV64⊕	1/2"	6,4	0,64	0	3,5	1	12	8	

N.B. The solenoid valve is suited for intercepting only fluids that are NOT potentially explosive.

Example: FX3110BV25b => FX3110BV25A60:

2-Way normally closed direct acting solenoid valve with housing for potentially explosive environments certified: CESI 03 ATEX 344 ExII2G/D Eex "d" IIC T6, with Connector G (ISO228) 1/4", Seals in FPM, Orifice 2,5 mm, Coil 24V DC (A60).

Pneumatic symbol

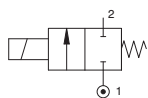

Diagram

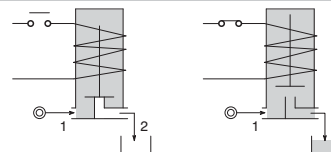

**Operational characteristic**

- Stainless Steel Body
- Container in light red coloured alloy
- Electrical connection 1/2" NPT
- Sealing elements in FPM

- **OPTIONS (if requested):**
- Advance ring in silver

**Technical characteristic**

Maximum admitted pressure (bar)	100
Maximum fluid viscosity (mm <sup>2</sup> /s)	25cSt
Ambient temperature (°C)	-10 + 40
Mounting position	with coil upwards
Weight (g.)	660



**Solenoid valves for fluids - FX3177**  
**Body and cover in Stainless Steel, with Connector G (ISO228) 3/8" - 1"**

FLUID CONTROL

2-Way normally closed servo-actuated diaphragm solenoid valve in stainless steel AISI 316, with housing for potentially explosive environments certified: CESI 03 ATEX 344 ExII2G/D Eex "d" IIC T6

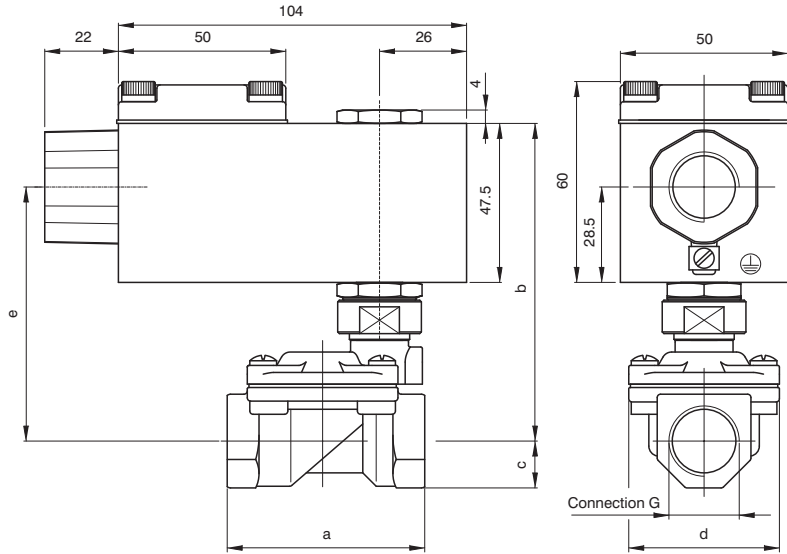

Connection G	a	b	c	d	e	Weight (gr.)
G3/8"	59	95	14	45	76	1120
G1/2"	59	95	14	45	76	1110
G3/4"	79	101	18	54	82	1100
G1"	96	110	20	72	91	1500

CODE	Connection G ISO 228	Orifice (mm)	KV (m <sup>3</sup> /h)	Differential pressure (bar)			Power Consumption		Temp. range (°C)
				Min	Max		AC Inrush	DC Watt	
					AC	DC			
FX3177CV121⊕	3/8"	12	2,2	0,15	15	15	12	8	-10 +140
FX3177DV121⊕	1/2"	12	2,5	0,15	15	15	12	8	
FX3177EV181⊕	3/4"	18	5,5	0,15	13	13	12	8	
FX3177FV251⊕	1"	24	10,2	0,15	10	10	12	8	

Coil ⊕ A6 Series
CURRENT
A6B=24 Volt (AC 50/60Hz)
A6E=220/230 Volt (AC 50/60Hz)
A60=24 Volt (DC)
A61=12 Volt (DC)

N.B. The solenoid valve is suited for intercepting only fluids that are NOT potentially explosive.

Example: FX3177CV121D => FX3177CV121A60.

2-Way normally closed servo-actuated diaphragm solenoid valve in stainless steel AISI 316, with housing for potentially explosive environments certified: CESI 03 ATEX 344 ExII2G/D Eex "d" IIC T6, with Connector G (ISO228) 3/8", Seals in FPM, Orifice 12 mm, Coil 24V DC (A60).

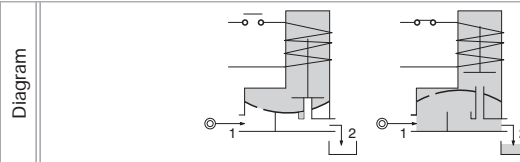

**Operational characteristic**

- Body and cover in Stainless Steel
- Container in light red coloured alloy
- Electrical connection 1/2" NPT
- Sealing elements in FPM

- **OPTIONS (if requested):**
- Version with slowed commutation

**Technical characteristic**

Minimum differential pressure (bar)	0,15
Maximum admitted pressure (bar)	25
Maximum fluid viscosity (mm <sup>2</sup> /s)	25cSt
Ambient temperature (°C)	-10 +40
Mounting position	Preferably with coil upwards

<b>MG Series coil (Size 30 mm), class F</b>							
Ordering code							
<b>MG t</b>							
VOLTAGE							
56=24 Volt (AC 50/60Hz)							
58=220/230 Volt (AC 50/60Hz)							
5=24 Volt (DC)							
4=12 Volt (DC)							
Options: Electrical connection via cables Special voltages and powers.							
<b>Operational characteristic</b>							
Class of insulation	Tolerance on AC voltage	Tolerance on DC voltage	Degree of protection with connector fitted	Continuous service	Electrical conn.	Connectors	Weight (g.)
F	+15% -10%	± 10%	IP65	ED100%	DIN 43650A	PG9 Code 10349000	120
<b>MI Series coil (Size 22 mm), class F</b>							
Ordering code							
<b>MI t</b>							
VOLTAGE							
56=24 Volt (AC 50/60Hz)							
58=220/230 Volt (AC 50/60Hz)							
5=24 Volt (DC)							
4=12 Volt (DC)							
21=48-50 Volt (AC 50/60Hz)							
Options: Electrical connection via cables Special voltages and powers.							
<b>Operational characteristic</b>							
Class of insulation	Tolerance on AC voltage	Tolerance on DC voltage	Degree of protection with connector fitted	Continuous service	Electrical conn.	Connectors	Weight (g.)
F	+15% -10%	± 10%	IP65	ED100%	DIN 43650A	PG9 Code 10349000	50
<b>MK Series coil (Size 36 mm), class H</b>							
Ordering code							
<b>MK t</b>							
VOLTAGE							
56=24 Volt (AC 50/60Hz)							
58=220/230 Volt (AC 50/60Hz)							
5=24 Volt (DC)							
4=12 Volt (DC)							
Options: Electrical connection via cables Special voltages and powers.							
<b>Operational characteristic</b>							
Class of insulation	Tolerance on AC voltage	Tolerance on DC voltage	Degree of protection without connector	Continuous service	Electrical conn.	Connectors	Weight (g.)
H	+15% -10%	± 10%	IP00	ED100%	DIN 43650A	PG9 Code 10349001	200
<b>Coils 2G Ex mb IIC T4-T6; II2D Ex mb IIIC T85°C-T135°C (Size 30 mm), Class H</b>							
Ordering code							
<b>XME t</b>							
VOLTAGE							
56=24 Volt (AC 50/60Hz)							
58=220/230 Volt (AC 50/60Hz)							
5=24 Volt (DC)							
4=12 Volt (DC)							
Options: Electrical connection via cables Special voltages and powers.							
<b>Operational characteristic</b>							
Class of insulation	Tolerance on AC voltage	Tolerance on DC voltage	Degree of protection without connector	Continuous service	Electrical conn.	Weight (g.)	
H	+15% -10%	± 10%	IP65	ED100%	3m cable.	250	



**Valve 2/2 N.C. input below - PVF Series**  
**Shutter seating inclined free from pipe knock**

FLUID CONTROL

**Pneumatic valve with inclined seating**

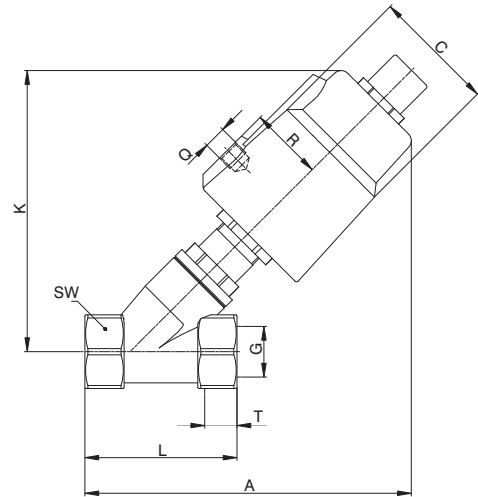

**Table of dimensions**

CODE AISI316	CODE AISI304	Connection G	Actuator (mm)	C (mm)	R (mm)	K (mm)	Q (mm)	T (mm)	A (mm)	L (mm)	SW (mm)
PVF40115-316	PVF40115-304	1/2"	40	50,5	27	111	1/8"	15	119	68	27
PVF50115-316	PVF50115-304	1/2"	50	60	33	124	1/8"	15	131	68	27
PVF50120-316	PVF50120-304	3/4"	50	60	33	128	1/8"	16	136	75	32
PVF50125-316	PVF50125-304	1"	50	60	33	136	1/8"	17	145	90	40
PVF63125-316	PVF63125-304	1"	63	75	41	162	1/8"	17	169	90	40
PVF63132-316	PVF63132-304	1 -1/4"	63	75	41	174	1/8"	21	187	116	50
PVF63140-316	PVF63140-304	1 -1/2"	63	75	41	175	1/8"	21	187	116	56
PVF63150-316	PVF63150-304	2"	63	75	41	183	1/8"	22	201	138	69
PVF125AL165-316	PVF125AL165-304	2-1/2"	125-Aluminium	148	74	302	1/4"	26	320	178	85
PVF125AL180-316	PVF125AL180-304	3"	125-Aluminium	148	74	313	1/4"	27	372	210	100

**Technical data**

CODE AISI316	CODE AISI304	Connection G	KV m <sup>3</sup> /h	Actuator (mm)	Maximum ΔP (bar)		Piloting pressure (bar)	Weight (gr.)
					Above seat	Under seat		
PVF40115-316	PVF40115-304	1/2"	4,8	40	16	13	3 - 8	765
PVF50115-316	PVF50115-304	1/2"	4,8	50	16	14		952
PVF50120-316	PVF50120-304	3/4"	10	50	16	14		1062
PVF50125-316	PVF50125-304	1"	14	50	16	8		1371
PVF63125-316	PVF63125-304	1"	14	63	16	13		2006
PVF63132-316	PVF63132-304	1 -1/4"	23	63	16	8		2575
PVF63140-316	PVF63140-304	1 -1/2"	30	63	16	5		2714
PVF63150-316	PVF63150-304	2"	70	63	9	3		3634
PVF125AL165-316	PVF125AL165-304	2-1/2"	107	125-Aluminium	16	9		9713
PVF125AL180-316	PVF125AL180-304	3"	157	125-Aluminium	16	5		13003

Pneumatic symbol

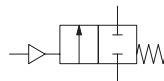

**Operational characteristic**

- High flow rate thanks to Body configuration with inclined seating.
- Anti water hammer functioning with input below shutter.
- Pneumatically operated valve with stainless steel Body, resistant to ambient corrosion.
- Self-levelling shutter to ensure improved sealing.
- Optical position indicator.
- May be used with back pressure for gaseous fluids.
- Self-adjusting maintenance free stuffer gasket package.
- Valves may be mounted in all positions.

**OPTIONS:**

- Connection type: GAS ISO / NPT

**Valve Body technical characteristics**

- Material: Stainless Steel AISI 316/304
- Fluid temperature: -10°C - +180°C
- Temperature: -10°C - +80°C
- Fluid viscosity: max. 600cSt.
- Shutter: PTFE.
- Gasket packet with PTFE, FKM stuffer

**Actuator technical characteristics**

- Body AISI 304
- Pilot fluid dry or lubricated air, gas and neutral fluids.
- Temperature fluid max. + 60°C.

**Proximity Sensor**

Ordering code

**PVF.t.S**

OUTPUT TYPE
01 = NPN (N.C.)
02 = NPN (N.O.)
03 = PNP (N.C.)
04 = PNP (N.O.)

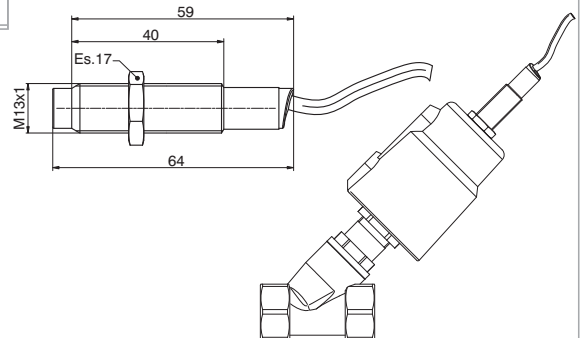

Nickel brass sensor, usable on valves up to size 2 inches for detection ON - OFF  
 Cable: 2m

**Operational characteristic**

Maximum current	Voltage field	Temperature (°C)	Detection Distance	Protection grade	Weight (gr.)
100 mA	10 - 30V DC	-10°C - +70°C	3mm (max) ± 10 %	IP67	68



"T" body version Pad valves

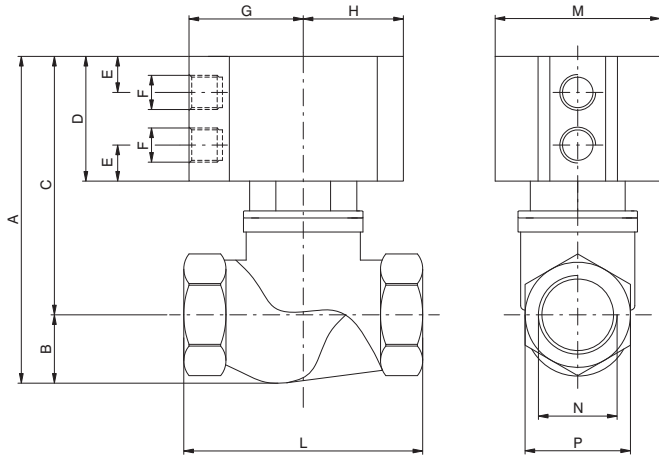

Ordering code

**PVA.B.a.p.T.c.s**

a	ACTING
	DE=Double acting
	SC=Normally closed SA=Normally open
p	PISTON
	N= Non magnetic M= Magnetic
C	CONNECTIONS
	A= G1/4"
	B= G3/8"
	C= G1/2"
	D= G3/4"
	E= G1"
	F= G1 1/4"
S	SEALS
	N= NBR
	V= FPM
	F= PTFE

TABLE OF DIMENSIONS

Connection (N)	Non magnetic version			Magnetic version			TECHNICAL DATA										
	A	C	D	A	C	D	B	E	F	G	H	L	M	P	Actuator (Ø)	Nominal Valve (Ø)	Weight (gr.)
G1/4"	93,5	77,5	41	97,5	81,5	45	16	10,25	G1/8"	32,5	28,5	64	47	25	Ø40	Ø13,5	350
G3/8"	93,5	77,5	41	97,5	81,5	45	16	10,25	G1/8"	32,5	28,5	64	47	25	Ø40	Ø13,5	350
G1/2"	93,5	78	41	99,5	82	45	17,5	10,25	G1/8"	32,5	28,5	68	47	30	Ø40	Ø15	400
G 3/4"	105	83	41	113	90	48	22	11,25	G1/8"	44	40	79	70	36	Ø63	Ø20,5	850
G1"	117	89	41	125	101	53	28	11,25	G1/8"	44	40	94	70	44	Ø63	Ø25	1100
G1 1/4"	131	103	48	136	108	53	28	11,25	G1/8"	44	40	110	70	55	Ø63	Ø30	1400
G1 1/2"	154	118	57	166	130	69	36	13,75	G1/8"	56	49	120	90	60	Ø80	Ø38	2100
G2"	169	124	57	181	136	69	45	13,75	G1/8"	56	49	140	90	73	Ø80	Ø49,5	3000

Pad valves, 2-ways, are a reliable and economic solution to control fluid. Pneumatically actuated by a compact double or single acting cylinder with 360° revolving connections. Standard seals in contact with fluid are made in NBR, FPM or PTFE. The barrel profile allows the use of Pneumax magnetic sensors series 1500 (see the Pneumax General catalogue, chapter 4).

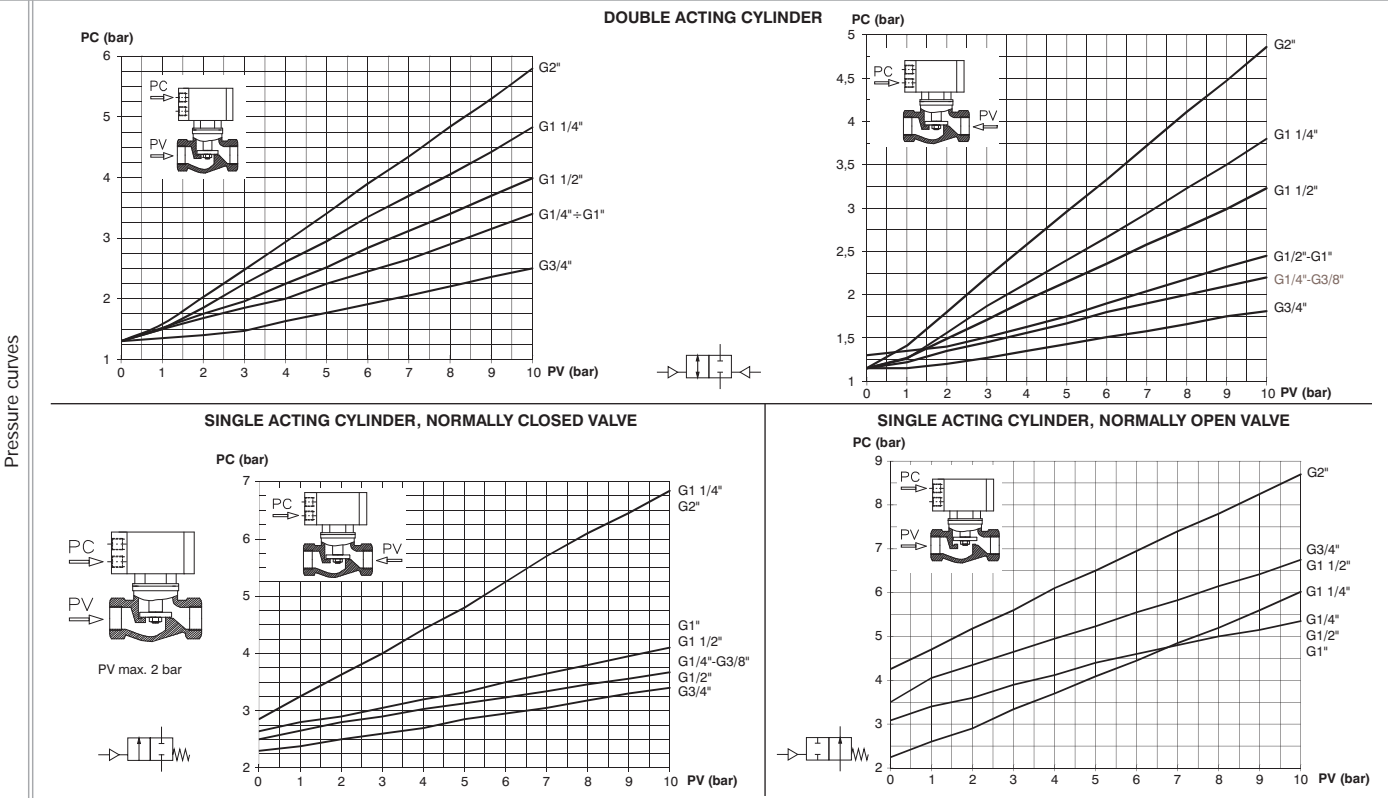

Operational characteristic

- Rear eye, Piston and Rod bushing = Anodized aluminium
- Cylinder = Aluminium alloy Anodized
- Spring = Zinc plated steel
- Seals = NBR, FPM, PTFE
- Piston rod = Chromed stainless steel
- Bushing, Bushing pad, Nut pad = Brass

Technical characteristic

Pneumatic cylinder fluid	Filtered and lubricated air or non
Valve fluid	Compatible fluid with gasket compounds available
Maximum working pressure (bar)	10
Temperature °C (non magnetic piston, NBR seals)	-5 / + 70
Temperature °C (non magnetic piston, FPM seals)	-5 / + 150
Temperature °C (non magnetic piston, PTFE seals)	-5 / + 150
Temperature °C (magnetic piston, NBR, FPM, PTFE seals)	-5 / + 70



# Pad valves 2/2 - PVA Series "Y" body version

FLUID CONTROL

## "Y" body version Pad valves

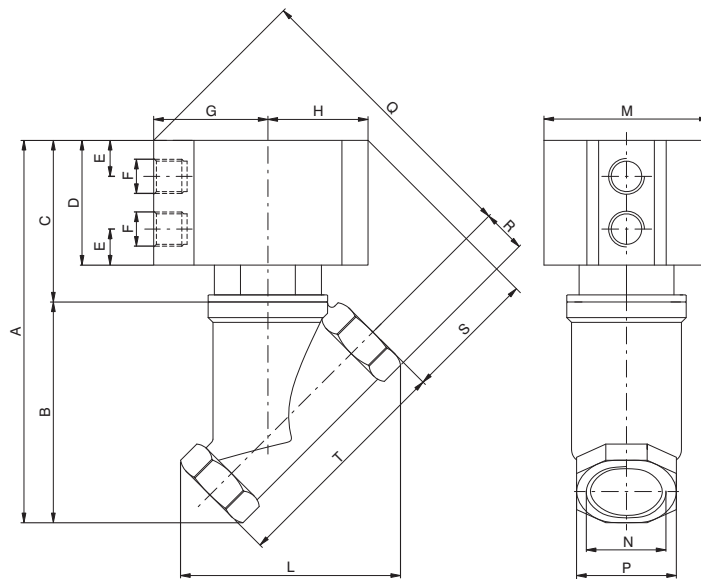

**Ordering code**  
**PVA.B.a.p.Y.C.S**

<b>A</b>	ACTING DE=Double acting SC=Normally closed SA=Normally open
<b>P</b>	PISTON N=Non magnetic M= Magnetic
<b>C</b>	CONNECTIONS A=G1/4" B=G3/8" C=G1/2" D=G3/4" E=G1" F=G1 1/4" G=G1 1/2" H=G2"
<b>S</b>	SEALS N=NBR V=FPM F=PTFE

### TABLE OF DIMENSIONS

Connection (N)	Non magnetic version					Magnetic version					TECHNICAL DATA												
	A	C	D	Q	S	A	C	D	Q	S	B	E	F	G	H	L	M	P	R	T	Actuator (Ø)	Nominal Valve (Ø)	Weight (gr.)
G1/4"	121	71	45	95	51	124	74	48	97	53	50	10,3	G1/8"	32,5	28,5	52	47	21	10,5	50	Ø40	Ø13	350
G3/8"	121	71	45	95	51	124	74	48	97	53	50	10,3	G1/8"	32,5	28,5	52	47	21	10,5	50	Ø40	Ø13	350
G1/2"	127	71	45	97	54	130	74	48	99	56	56	10,3	G1/8"	32,5	28,5	57	47	27	13,5	56	Ø40	Ø13	400
G3/4"	148	80	48	119	66	201	133	104	175	92	68	11,3	G1/8"	44	40	70	70	32	16	66	Ø63	Ø18	850
G1"	159	75	48	123	75	215	131	104	175	92	84	11,3	G1/8"	44	40	82	70	38	19	78	Ø63	Ø21,5	850
G1 1/4"	184	91	65	140	70	231	138	112	172	96	93	11,3	G1/8"	44	40	105	70	47	23,5	101	Ø63	Ø30	1200
G1 1/2"	180	99	81	173	85	255	129	111	187	107	126	13,8	G1/8"	56	49	125	90	55	27,5	113	Ø80	Ø36	2000
G2"	246	106	88	182	88	269	129	111	203	109	140	13,8	G1/8"	56	49	136	90	68	34	125	Ø80	Ø46	2300

Pad valves, 2-ways, are a reliable and economic solution to control fluid. Pneumatically actuated by a compact double or single acting cylinder with 360° revolving connections. Standard seals in contact with fluid are made in NBR, FPM or PTFE. The barrel profile allows the use of Pneumax magnetic sensors series 1500 (see the Pneumax General catalogue, chapter 4).

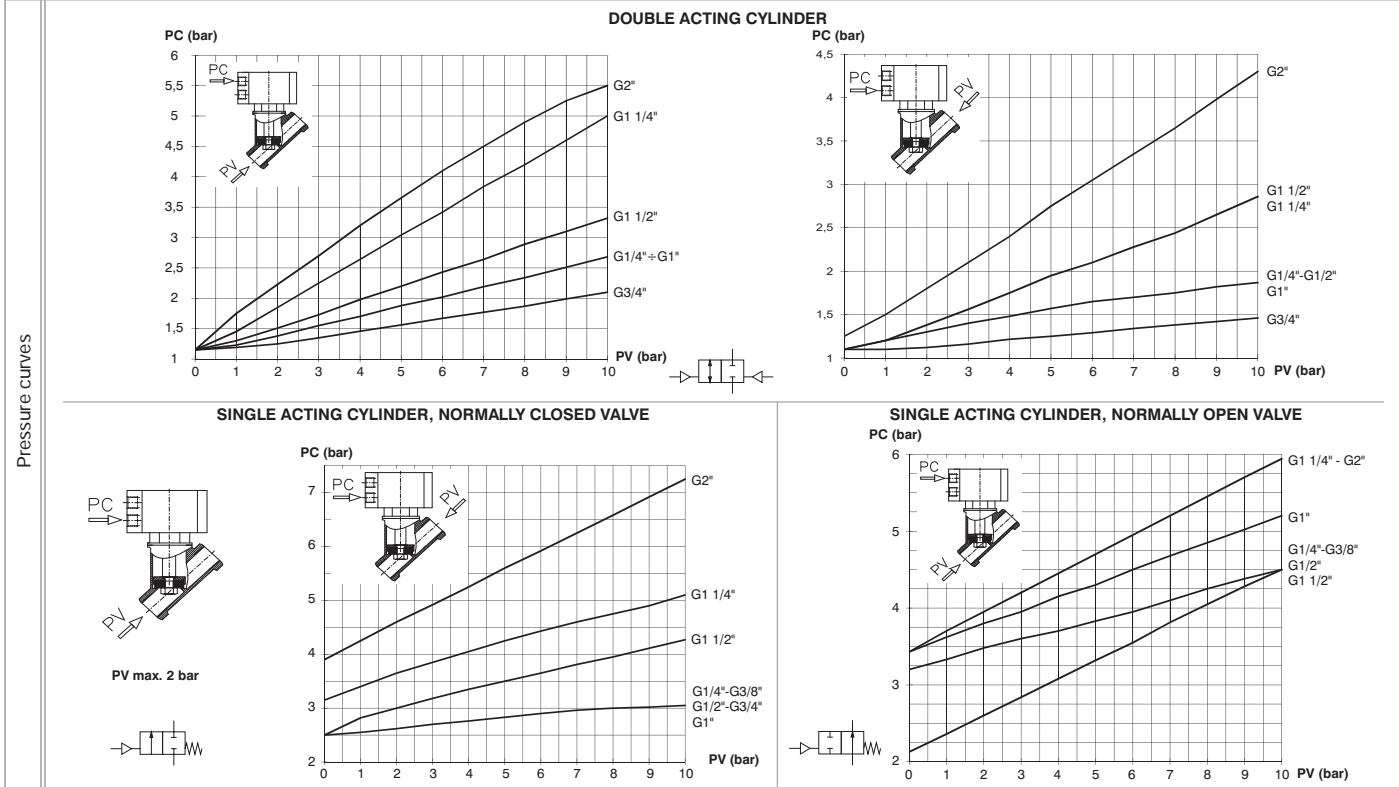

Operational characteristic	Technical characteristic	
<ul style="list-style-type: none"> <li>Rear eye, Piston and Rod bushing = Anodized aluminium</li> <li>Cylinder = Aluminium alloy Anodized</li> <li>Spring = Zinc plated steel</li> <li>Seals = NBR, FPM, PTFE</li> <li>Piston rod = Chromed stainless steel</li> <li>Bushing, Bushing pad, Nut pad = Brass</li> </ul>	Pneumatic cylinder fluid	Filtered and lubricated air or non
	Valve fluid	Compatible fluid with gasket compounds available
	Maximum working pressure (bar)	10
	Temperature °C (non magnetic piston, NBR seals)	-5 / + 70
	Temperature °C (non magnetic piston, FPM seals)	-5 / + 150
	Temperature °C (non magnetic piston, PTFE seals)	-5 / + 150
	Temperature °C (magnetic piston, NBR, FPM, PTFE seals)	-5 / + 70