

### General

The large flow valves and solenoid poppet valves for compressed air and vacuum are manufactured for 3/2 and 2/2 versions only, either normally close and normally open.

For the compressed air operation, the application is similar to the equivalent spool valves while for the vacuum operation a particular attention should be paid to the valve selected and its connection to the pump.

For the electric pilot it is used a normal miniature solenoid M2 with pneumatic actuator and the special miniature solenoid M2/V with vacuum.

**The ordering code are referring to the solenoid valves with mechanics "M2" or "M2/V" assembled (see Series 300). (Coil are not included and have to be ordered separately).**

Coil  homologated are available (see 300 Series).

### Construction characteristics

	G 3/8"	G 1/2" - G 3/4"	G 1"	G 1 1/2"
Body	Aluminium	Zinc alloy	Aluminium	Aluminium
Bottom plates	Aluminium			
Actuators	NBR			
Pistons	Aluminium			
Actuators rod	Stainless steel			
Spring	Stainless steel			
Piston seals	NBR			

### Use and maintenance

These valves are a mean life of 10 to 15 millions of cycles under normal operating conditions.

Lubrication is not required for good operation but we recommend good filtration to avoid dirty deposit causing malfunction.

Check that the operating conditions: pressure, temperature and so on are as suggested.

The exhaust port of the distributor has to be protected in a dusty and dirty environment.

For these products, according to the construction technique and special application, is not required any maintenance with parts replacement. When necessary it is sufficient to clean the internal parts.

When it is used the solenoid valves with internal pilot, either for air or vacuum, pay attention that the exhaust flow is not same as inlet flow otherwise there will not be sufficient differential pressure for depression for the piston. This happen normally with poppet valves because they have no closed centres position and an insufficient pressure will put the valve in exhaust position through the port 3. In this case choose the external pilot version.

### Vacuum valves connections

#### NORMALLY CLOSED INTERNAL PILOT

779/V.32.0.1AC

773/V.32.0.1AC P = 1 = EXHAUST

771/V.32.0.1AC A = 2 = OUTLET

R = 3 = PUMP

#### NORMALLY OPEN INTERNAL PILOT

779/V.32.0.1AA

773/V.32.0.1AA P = 1 = PUMP

771/V.32.0.1AA A = 2 = OUTLET

R = 3 = EXHAUST

#### NORMALLY CLOSED EXTERNAL PILOT

779/V.32.0.1C

773/V.32.0.1C

771/V.32.0.1C

P = 1 = PUMP

A = 2 = OUTLET

R = 3 = EXHAUST

#### NORMALLY OPEN EXTERNAL PILOT

779/V.32.0.1A

773/V.32.0.1A

771/V.32.0.1A

P = 1 = EXHAUST

A = 2 = OUTLET

R = 3 = PUMP

779/V.32.11.1C

773/V.32.11.1C

771/V.32.11.1C

779/V.32.11.1A

773/V.32.11.1A

771/V.32.11.1A

**Pneumatic - Spring**

Ordering code
<b>779.32.11.F</b>
FUNCTION
<b>F</b> 1C = Normally Closed
1A = Normally Open

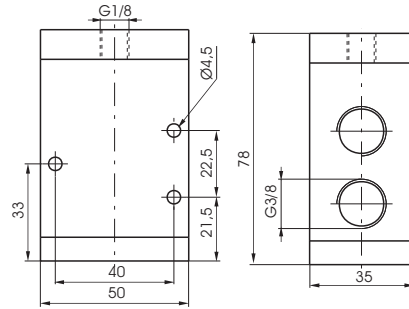

Weight gr. 360  
Attention : for the Normally open version, connect the inlet port to the exhaust port No "3".  
Minimum piloting pressure 2,5 bar

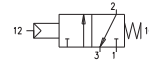
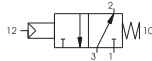

Operational characteristic	Fluid	Max working pressure (bar)	Temperature °C	Flow rate at 6 bar with Δp=1 (Nl/min)	Orifice size (mm)	Working ports size	Pilot ports size
		Filtered and lubricated air	10	-5 - +70	1800	10	G 3/8"

**Solenoid - Spring**

Ordering code
<b>779.32.0.F.M2</b>
FUNCTION
1AC = Internal Pilot N.C.
<b>F</b> 1C = External Pilot Normally Closed
1AA = Internal Pilot N.A.
1A = External Pilot Normally Open

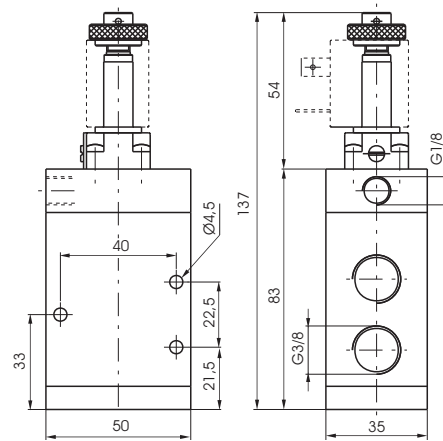

Weight gr. 420  
Minimum working pressure 2,5 bar (External Pilot) - 3 bar (Internal Pilot)

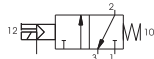
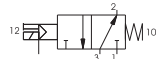
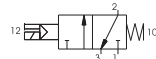
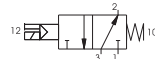

Operational characteristic	Fluid	Max working pressure (bar)	Temperature °C	Flow rate at 6 bar with Δp=1 (Nl/min)	Orifice size (mm)	Working ports size	Pilot ports size
		Filtered and lubricated air	10	-5 - +50	1800	10	G 3/8"

**Pneumatic - Spring**

Ordering code

**779/V.32.11.F**

FUNCTION

- 1C = Normally Closed
- 1A = Normally Open

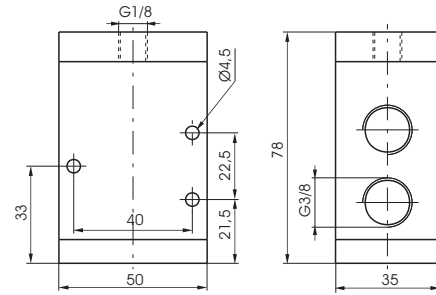

Weight gr. 360  
Minimum piloting pressure 2 bar

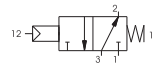
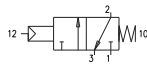

**Operational characteristic**

Fluid	Temperature °C	Orifice size (mm)	Working ports size	Pilot ports size
Vacuum	-5 - +70	10	G 3/8"	G 1/8"

**Solenoid - Spring - Internal Pilot**

Ordering code

**779/V.32.0.F.M2/V**

FUNCTION

- 1AA = Normally Open
- 1AC = Normally Closed

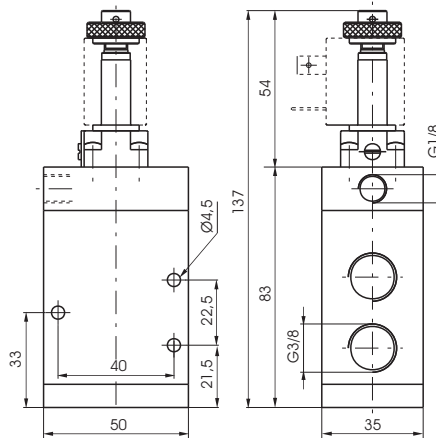

Weight gr. 420

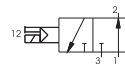
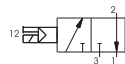

**Operational characteristic**

Fluid	Temperature °C	Orifice size (mm)	Working ports size	Pilot ports size
Vacuum	-5 - +50	10	G 3/8"	G 1/8"

**Solenoid - Spring - External Pilot**

Ordering code

**779/V.32.0.F.M2**

FUNCTION

- 1A = Normally Open
- 1C = Normally Closed

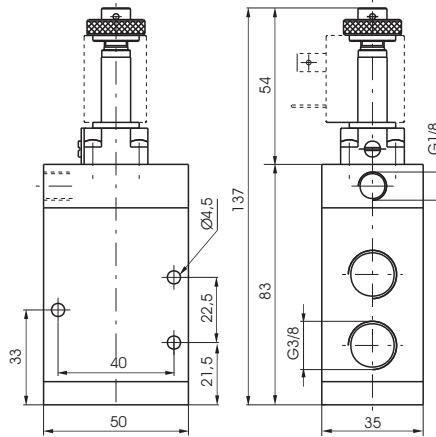

Weight gr. 420  
Minimum working pressure 2 bar (External Pilot)

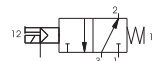
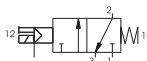

**Operational characteristic**

Fluid	Temperature °C	Orifice size (mm)	Working ports size	Pilot ports size
Vacuum	-5 - +50	10	G 3/8"	G 1/8"

**Pneumatic - Spring**

Ordering code
<b>772.32.11.1C</b>

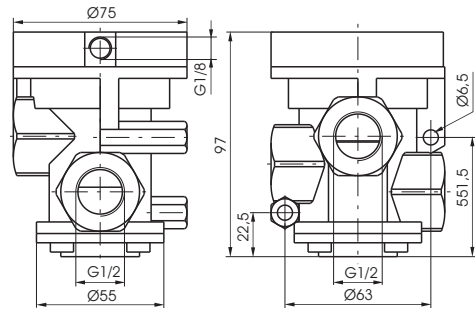

Weight gr. 1100  
Normally Closed  
Minimum piloting pressure 2,5 bar

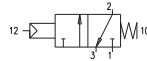

Operational characteristic	Fluid	Max working pressure (bar)	Temperature °C	Flow rate at 6 bar with Δp=1 (NI/min)	Orifice size (mm)	Working ports size	Pilot ports size
		Filtered and lubricated air	10	-5 - +70	4800	15	G 1/2"

**Solenoid - Spring**

Ordering code
<b>772.32.0.F.M2</b>
FUNCTION
<b>F</b> 1AC = Internal Pilot Normally Closed
1C = External Pilot Normally Closed

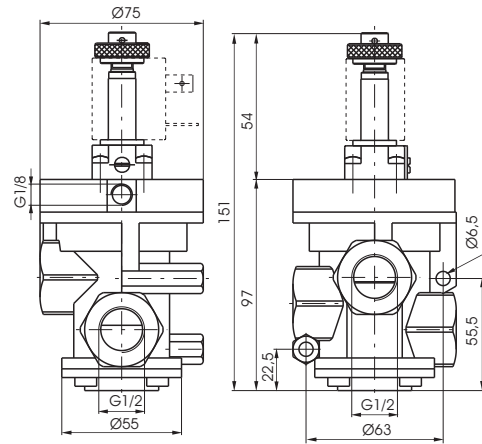

Weight gr. 1160  
Minimum working pressure 2,5 bar (External Pilot) - 3 bar (Internal Pilot)

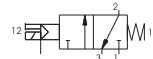
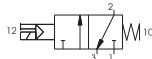

Operational characteristic	Fluid	Max working pressure (bar)	Temperature °C	Flow rate at 6 bar with Δp=1 (NI/min)	Orifice size (mm)	Working ports size	Pilot ports size
		Filtered and lubricated air	10	-5 - +50	4800	15	G 1/2"

2

**Pneumatic - Spring**

Ordering code  
**772/V.32.11.F**

FUNCTION  
**F**  
 1C = Normally Closed  
 1A = Normally Open

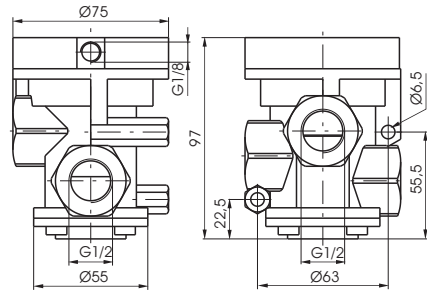

Weight gr. 1100  
Minimum piloting pressure 2 bar

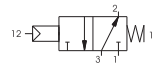
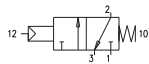

Operational characteristic	Fluid	Temperature °C	Orifice size (mm)	Working ports size	Pilot ports size
	Vacuum		-5 - +70	15	G 1/2"

**Solenoid - Spring - Internal Pilot**

Ordering code  
**772/V.32.0.F.M2/V**

FUNCTION  
**F**  
 1AA = Normally Open  
 1AC = Normally Closed

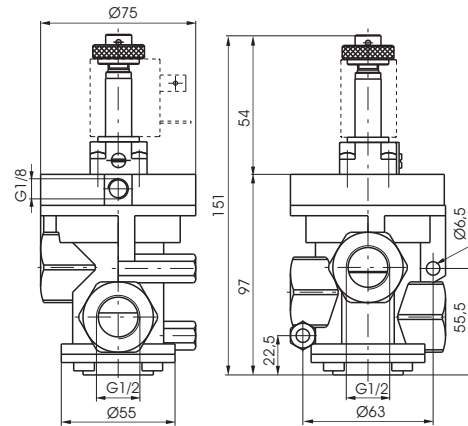

Weight gr. 1160

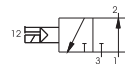
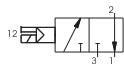

Operational characteristic	Fluid	Temperature °C	Orifice size (mm)	Working ports size	Pilot ports size
	Vacuum		-5 - +50	15	G 1/2"

**Solenoid - Spring - External Pilot**

Ordering code  
**772/V.32.0.F.M2**

FUNCTION  
**F**  
 1A = Normally Open  
 1C = Normally Closed

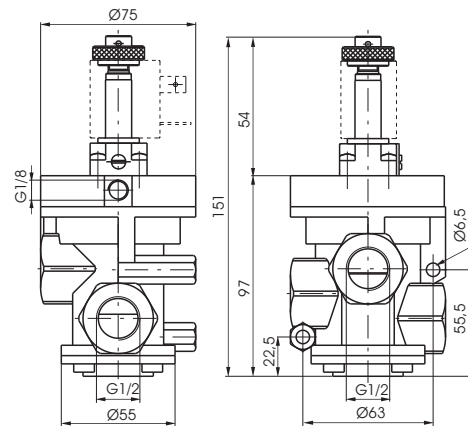

Weight gr. 1160  
Minimum working pressure 2 bar (External Pilot)

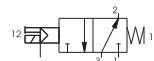
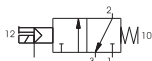

Operational characteristic	Fluid	Temperature °C	Orifice size (mm)	Working ports size	Pilot ports size
	Vacuum		-5 - +50	15	G 1/2"

**Pneumatic - Spring**

Ordering code
<b>773.32.11.1C</b>

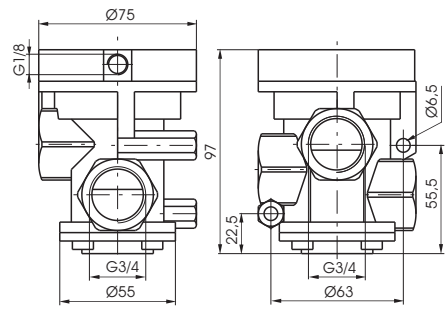

Weight gr. 990

Normally Closed  
Minimum piloting pressure 2,5 bar

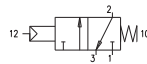

Operational characteristic	Fluid	Max working pressure (bar)	Temperature °C	Flow rate at 6 bar with $\Delta p=1$ (NI/min)	Orifice size (mm)	Working ports size	Pilot ports size
		Filtered and lubricated air	10	-5 - +70	6100	20	G 3/4"

**Solenoid - Spring**

Ordering code
<b>773.32.0.F.M2</b>
FUNCTION
<b>F</b> 1AC = Internal Pilot Normally Closed
1C = External Pilot Normally Closed

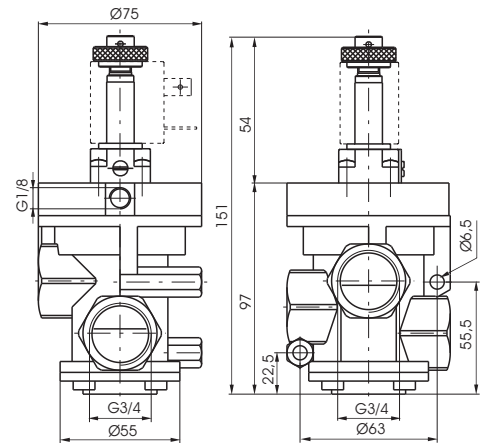

Weight gr. 1050

Minimum working pressure 2,5 bar (External Pilot) - 3 bar (Internal Pilot)

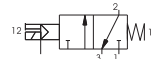
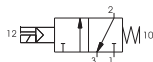

Operational characteristic	Fluid	Max working pressure (bar)	Temperature °C	Flow rate at 6 bar with $\Delta p=1$ (NI/min)	Orifice size (mm)	Working ports size	Pilot ports size
		Filtered and lubricated air	10	-5 - +50	6100	20	G 3/4"

2

**Pneumatic - Spring**

Ordering code
<b>773/V.32.11.F</b>
FUNCTION
<b>F</b> 1C = Normally Closed
1A = Normally Open

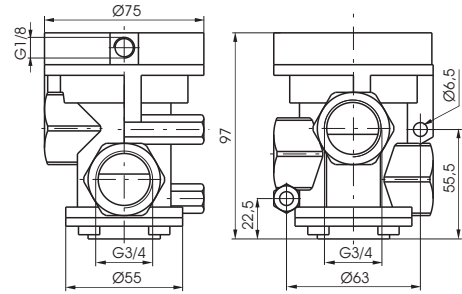

Weight gr. 990  
Minimum piloting pressure 2 bar

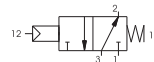
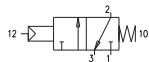

Operational characteristic	Fluid	Temperature °C	Orifice size (mm)	Working ports size	Pilot ports size
	Vacuum		-5 - +70	20	G 3/4"

**Solenoid - Spring - Internal Pilot**

Ordering code
<b>773/V.32.0.F.M2/V</b>
FUNCTION
<b>F</b> 1AA = Normally Open
1AC = Normally Closed

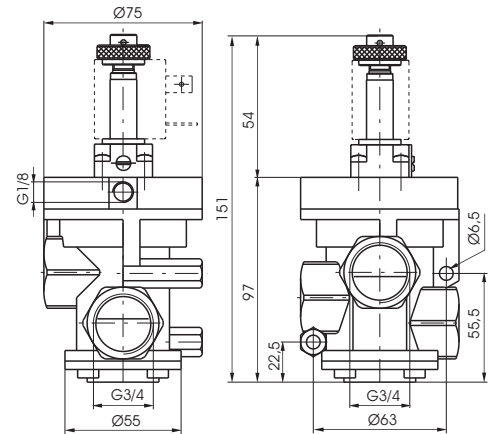

Weight gr. 1050

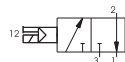

Operational characteristic	Fluid	Temperature °C	Orifice size (mm)	Working ports size	Pilot ports size
	Vacuum		-5 - +50	20	G 3/4"

**Solenoid - Spring - External Pilot**

Ordering code
<b>773/V.32.0.F.M2</b>
FUNCTION
<b>F</b> 1A = Normally Open
1C = Normally Closed

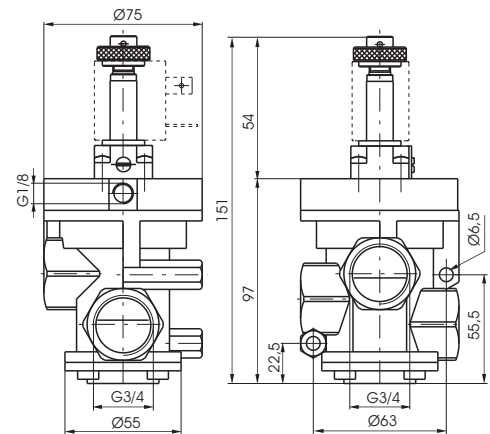

Weight gr. 1050  
Minimum working pressure 2 bar (External Pilot)

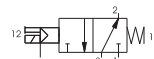

Operational characteristic	Fluid	Temperature °C	Orifice size (mm)	Working ports size	Pilot ports size
	Vacuum		-5 - +50	20	G 3/4"

**Pneumatic - Spring**

Ordering code
<b>771.32.11.1C</b>

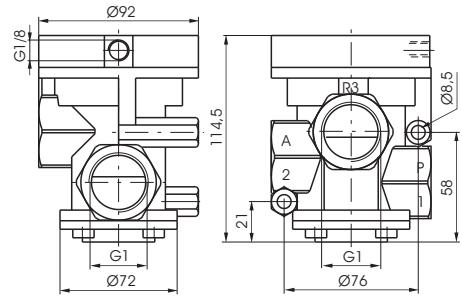

Weight gr. 1060  
Normally Closed  
Minimum piloting pressure 2,5 bar

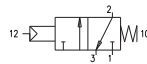

Operational characteristic	Fluid	Max working pressure (bar)	Temperature °C	Flow rate at 6 bar with Δp=1 (NI/min)	Orifice size (mm)	Working ports size	Pilot ports size
	Filtered and lubricated air	10	-5 - +70	12000	25	G 1"	G 1/8"

**Solenoid - Spring**

Ordering code
<b>771.32.0.F.M2</b>
FUNCTION
<b>F</b> 1AC = Internal Pilot Normally Closed
1C = External Pilot Normally Closed

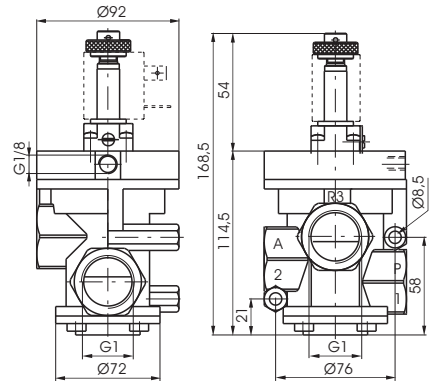

Weight gr. 1120  
Minimum working pressure 2,5 bar (External Pilot) - 3 bar (Internal Pilot)

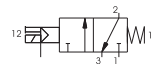
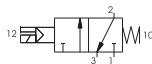

Operational characteristic	Fluid	Max working pressure (bar)	Temperature °C	Flow rate at 6 bar with Δp=1 (NI/min)	Orifice size (mm)	Working ports size	Pilot ports size
	Filtered and lubricated air	10	-5 - +50	12000	25	G 1"	G 1/8"

2

**Pneumatic - Spring**

Ordering code
<b>771/V.32.11.F</b>
FUNCTION
<b>F</b> 1C = Normally Closed
1A = Normally Open

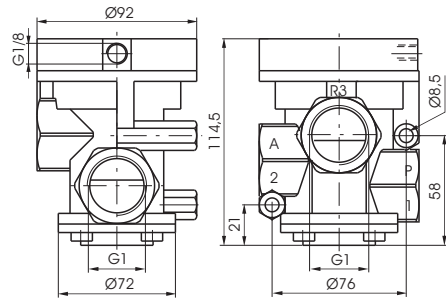

Weight gr. 1060  
Minimum piloting pressure 2 bar

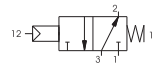
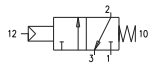

Operational characteristic	Fluid	Temperature °C	Orifice size (mm)	Working ports size	Pilot ports size
	Vacuum		-5 - +70	25	G 1"

**Solenoid - Spring - Internal Pilot**

Ordering code
<b>771/V.32.0.F.M2/V</b>
FUNCTION
<b>F</b> 1AA = Normally Open
1AC = Normally Closed

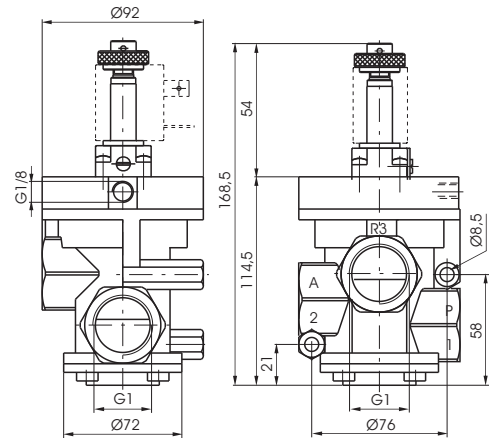

Weight gr. 1120

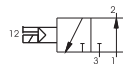
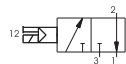

Operational characteristic	Fluid	Temperature °C	Orifice size (mm)	Working ports size	Pilot ports size
	Vacuum		-5 - +50	25	G 1"

**Solenoid - Spring - External Pilot**

Ordering code
<b>771/V.32.0.F.M2</b>
FUNCTION
<b>F</b> 1A = Normally Open
1C = Normally Closed

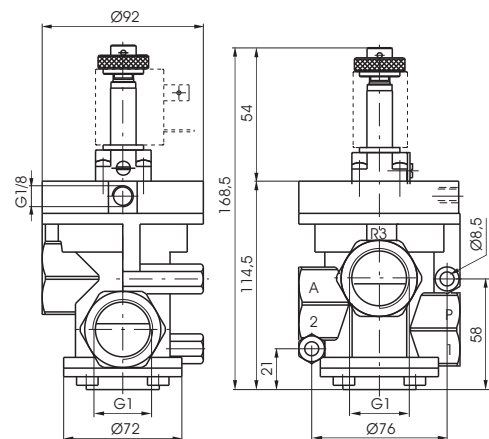

Weight gr. 1120  
Minimum working pressure 2 bar (External Pilot)

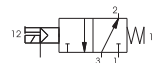
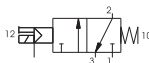

Operational characteristic	Fluid	Temperature °C	Orifice size (mm)	Working ports size	Pilot ports size
	Vacuum		-5 - +50	25	G 1"



**Pneumatic - Spring**

Ordering code
<b>776/V.22.11.1C</b>

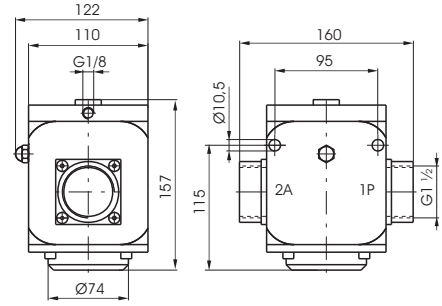

Weight gr. 3950  
Normally Closed  
Minimum piloting pressure 2 bar

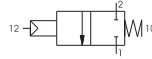

Operational characteristic	Fluid	Temperature °C	Orifice size (mm)	Working ports size	Pilot ports size
	Vacuum		-5 - +70	38	G1 1/2"

**Solenoid - Spring**

Ordering code
<b>776/V.22.0.1C.S</b>
<b>S</b> SOLENOID CODE See Valves Series 300 Type "S"

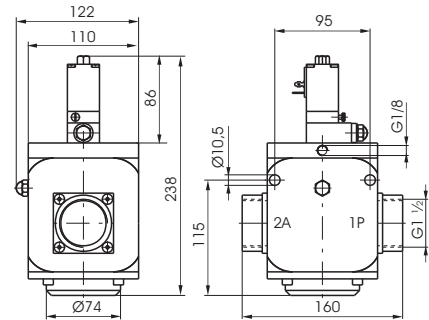

Weight gr. 4450  
External Pilot Normally Closed  
Minimum working pressure 2 bar

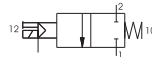

Operational characteristic	Fluid	Temperature °C	Orifice size (mm)	Working ports size	Pilot ports size
	Vacuum		-5 - +50	38	G1 1/2"

**Pneumatic - Spring**

Ordering code
<b>776/V.32.11.F</b>
<b>F</b> FUNCTION 1C = Normally Closed 1A = Normally Open

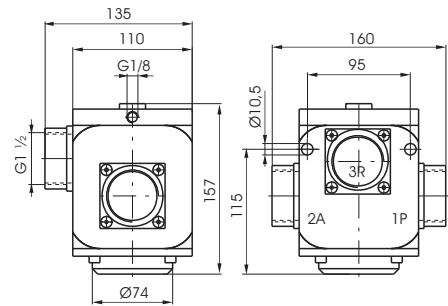

Weight gr. 3900  
Minimum piloting pressure 2 bar

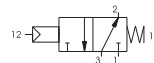
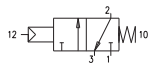

Operational characteristic	Fluid	Temperature °C	Orifice size (mm)	Working ports size	Pilot ports size
	Vacuum		-5 - +70	38	G1 1/2"

**Solenoid - Spring**

Ordering code
<b>776/V.32.0.F.S</b>
<b>F</b> FUNCTION 1C = External Pilot Normally Closed 1A = External Pilot Normally Open
<b>S</b> SOLENOID CODE See Valves Series 300 Type "S"

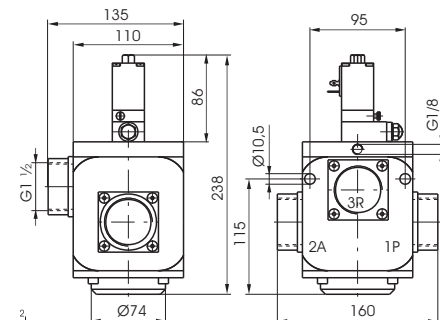

Weight gr. 4500  
Minimum working pressure 2 bar

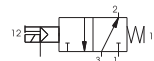
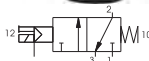

Operational characteristic	Fluid	Temperature °C	Orifice size (mm)	Working ports size	Pilot ports size
	Vacuum		-5 - +50	38	G1 1/2"



**General**

This new range of G1/2" and G3/4" pilot and solenoid operated poppet valves represents an evolution of the current popular Zama series. The main feature of this new series is the high impact resistant thermoplastic used to mould the valve components.

The use of this material results in a versatile, lightweight and economical valve. The new series also has other technical and functional enhancements over the existing range. Firstly, the traditional piston lip seal has been replaced with a rolling diaphragm, thereby eliminating frictional wear and tear to this seal. The new series (with the exception of certain vacuum models) also features a seal, which separates port 3 from the piston head. The inclusion of this seal has enhanced the valve's performance and allows the valve to be used as normally open (a configuration not possible in the Zama series).

Solenoid operated valves (both internal and external pilot versions) are fitted with a quick exhaust unit, which reduces the return stroke operating time by 60%. The bulk of the valves in this series use the MP type operator, the exception being internally piloted vacuum models, which use the MV operator. These operators differ from the M2 type in that they have self-tapping mounting screws for use in plastics.

Coils **CALUS** homologated are also available. (see series 300).

**Construction characteristics**

Body, operator and end cover	High resistance technopolymer
Seals and poppets	Oil resistant rubber (NBR)
Piston and shaft	Acetal resin
Springs	AISI 302 stainless steel
Diaphragm	Oil resistant rubber coated (NBR)

**Use and maintenance**

Under correct working conditions the average life of this series of valves is 10 15 million cycles. Lubrication is not required but correct air filtration is recommended.

It is also important to ensure that the application parameters are in line with those indicated in the technical specification of this product: pressure, temperature....

The valves, thanks to their construction design, do not require maintenance involving replacement of parts; when necessary it is possible to carefully clean and remove any dirt that might have accumulated internally.

**Air valve port layout:**

- Normally closed: 1 = LINE IN  
2 = CONSUMPTION  
3 = EXHAUST
- Normally open: 1 = EXHAUST  
2 = CONSUMPTION  
3 = LINE IN

**Vacuum valve port layout:**

- Normally closed internal pilot 1 = EXHAUST
- Normally open (servoassisted) external pilot 2 = CONSUMPTION  
3 = PUMP
- Normally open internal pilot 1 = PUMP
- Normally closed (servoassisted) external pilot 2 = CONSUMPTION  
3 = EXHAUST

**MINIMUM WORKING PRESSURE DIAGRAM (Valves for compressed air)  
PNEUMATIC/SPRING AND EXTERNAL SOLENOID PILOT VERSION**

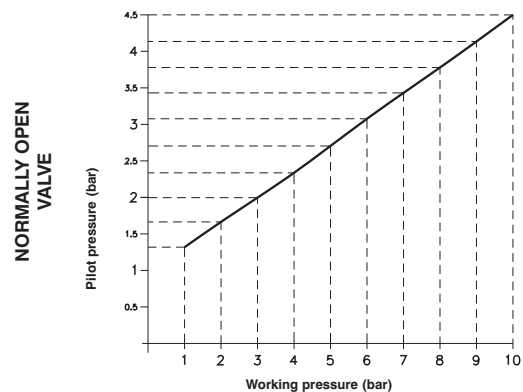
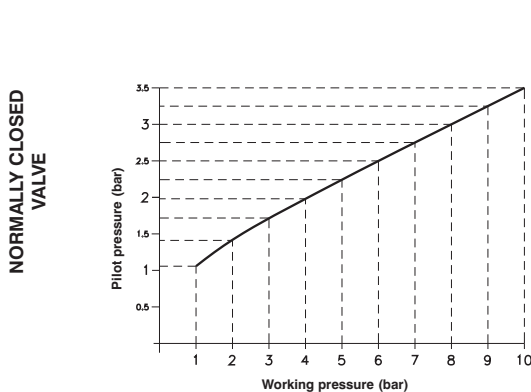

3/2

**Valve  
Pneumatic spring**

Ordering code

**T772.32.11.1**

*Normally closed*

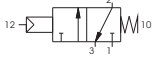

*Normally open*

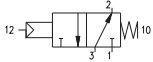

Weight gr. 350

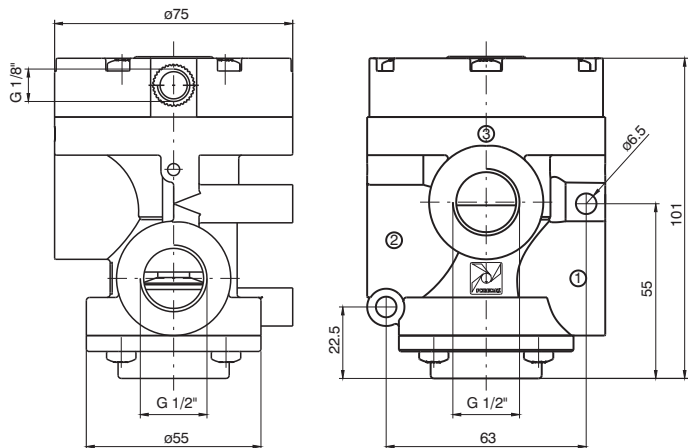

Minimum working pressure: see diagram at General page

3/2

**Solenoid valve  
Solenoid spring**



Weight gr. 390

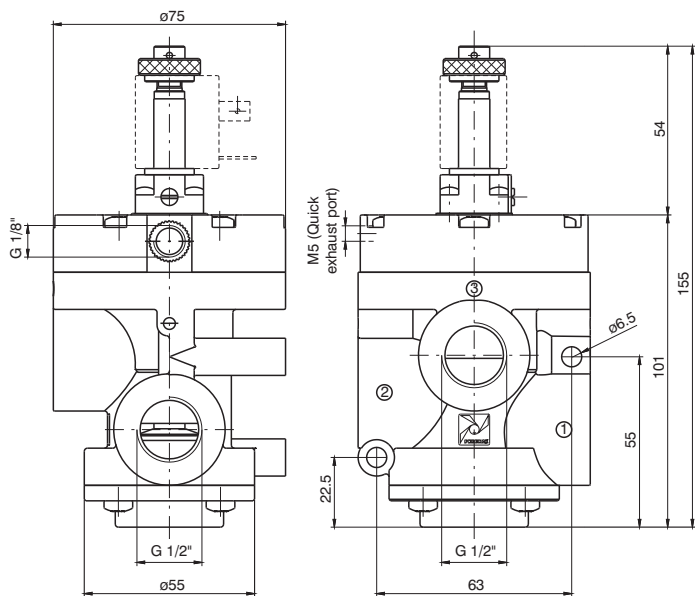

Ordering code

<i>Internal pilot</i>	<i>Servoassisted external pilot</i>	<i>Internal pilot with quick exhaust</i>	<i>Servoassisted external pilot with quick exhaust</i>
<p><b>T772.32.0.1AC.MP</b> <i>Normally closed</i></p>	<p><b>T772.32.0.1.MP</b> <i>Normally closed</i></p>	<p><b>T772S.32.0.1AC.MP</b> <i>Normally closed</i></p>	<p><b>T772S.32.0.1.MP</b> <i>Normally closed</i></p>
<p><b>T772.32.0.1AA.MP</b> <i>Normally open</i></p>	<p><i>Normally open</i></p>	<p><b>T772S.32.0.1AA.MP</b> <i>Normally open</i></p>	<p><i>Normally open</i></p>
<p>Minimum working pressure: 2.5 bar</p>	<p>Minimum working pressure: see diagram at General page</p>	<p>Minimum working pressure: 2.5 bar</p>	<p>Minimum working pressure: see diagram at General page</p>

Operational characteristics	Fluid	Max working pressure	Operating temperature		Flow rate at 6 bar with Δp = 1 bar	Orifice size	Working port size	Pilot ports size
	Filtered and lubricated or non lubricated air	10 bar	min. -5° C	max. +50°C	4100 NI/min	mm 15	G 1/2"	G 1/8"

3/2

**Valve  
Pneumatic spring**

Ordering code

**T772/V.32.11.1**

*Normally open*

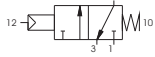

*Normally closed*

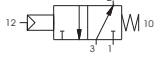

Weight gr. 350

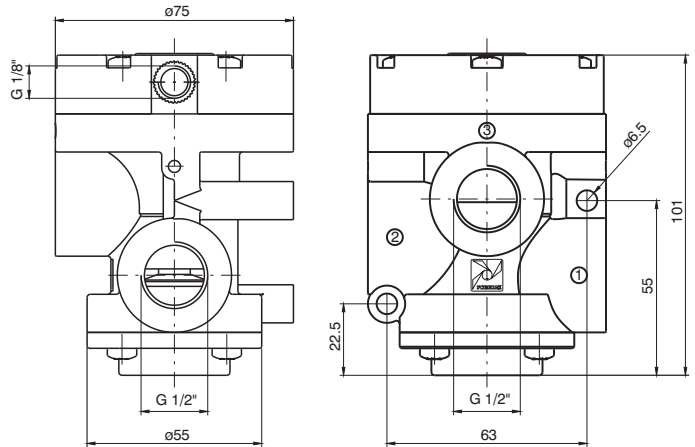

Minimum working pressure: 2,5 bar

**Solenoid valve  
Solenoid spring**

3/2



Weight gr. 390

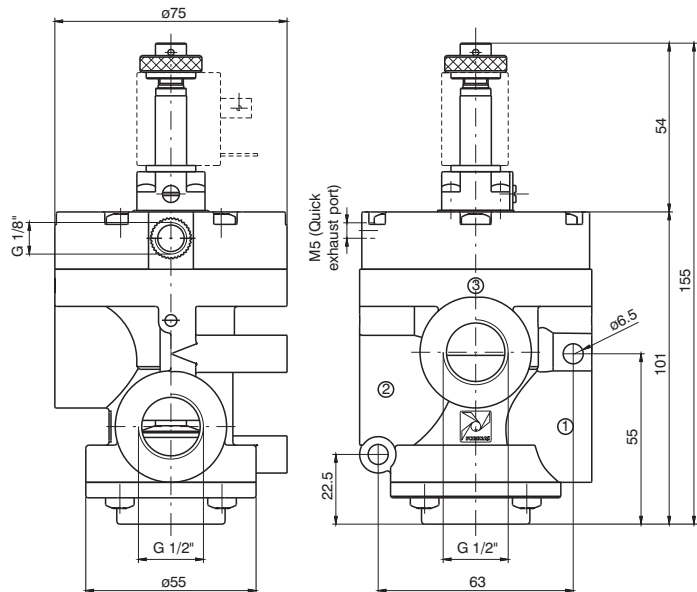

Ordering code

*Internal pilot*

*Servoassisted external pilot*

*Servoassisted external pilot  
with quick exhaust*

**T772/V.32.0.1AA.MV**

*Normally open*

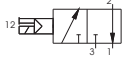

**T772/V.32.0.1.MP**

*Normally open*

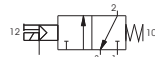

**T772/VS.32.0.1.MP**

*Normally open*

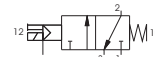

**T772/V.32.0.1AC.MV**

*Normally closed*

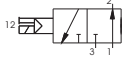

*Normally closed*

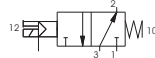

*Normally closed*

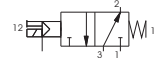

Minimum working pressure: 2.5 bar

Operational characteristics	Fluid	Operating temperature		Orifice Size	Working port size	Pilot ports size
	Vacuum	min.	max.			
		-5°C	+50°C	mm 15	G 1/2"	G 1/8"



3/2

**Valve**  
**Pneumatic spring**

Ordering code

**T773.32.11.1**

*Normally closed*



*Normally open*

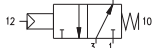

Weight gr. 330

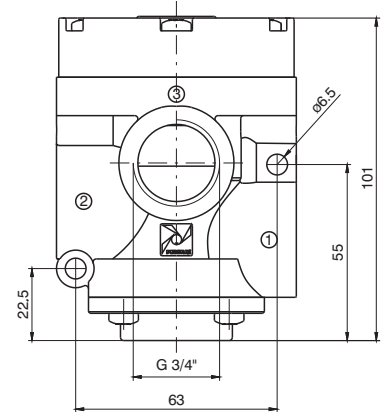
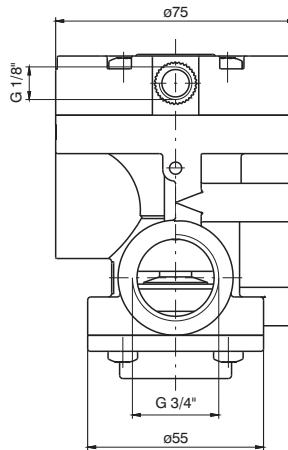

Minimum working pressure: see diagram at General page

3/2

**Solenoid valve**  
**Solenoid spring**



Weight gr. 370

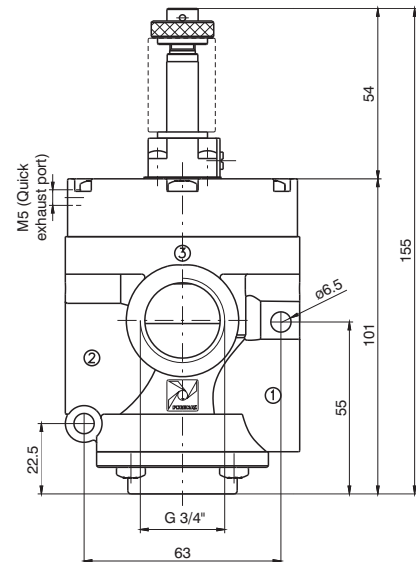
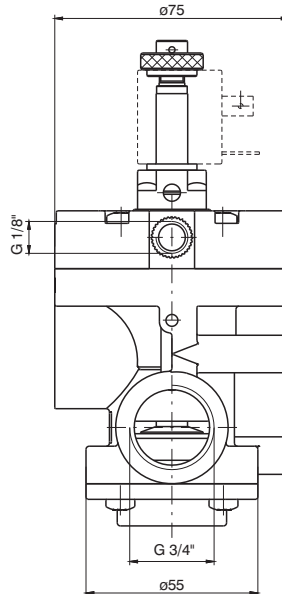

Ordering code

Internal pilot	Servoassisted external pilot	Internal pilot with quick exhaust	Servoassisted external pilot with quick exhaust
<p><b>T773.32.0.1AC.MP</b> <i>Normally closed</i></p>	<p><b>T773.32.0.1.MP</b> <i>Normally closed</i></p>	<p><b>T773S.32.0.1AC.MP</b> <i>Normally closed</i></p>	<p><b>T773S.32.0.1.MP</b> <i>Normally closed</i></p>
<p><b>T773.32.0.1AA.MP</b> <i>Normally open</i></p>	<p><i>Normally open</i></p>	<p><b>T773S.32.0.1AA.MP</b> <i>Normally open</i></p>	<p><i>Normally open</i></p>
<p>Minimum working pressure: 2.5 bar</p>	<p>Minimum working pressure: see diagram at General page</p>	<p>Minimum working pressure: 2.5 bar</p>	<p>Minimum working pressure: see diagram at General page</p>

Operational characteristics	Fluid	Max working pressure	Operating temperature		Flow rate at 6 bar with Δp = 1 bar	Orifice size	Working port size	Pilot ports size
	Filtered and lubricated or non lubricated air	10 bar	min. -5° C	max. +50°C	6400 NI/min	mm 20	G 3/4"	G 1/8"

3/2

**Valve**  
**Pneumatic spring**

Ordering code

**T773/V.32.11.1**

*Normally open*

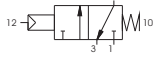

*Normally closed*

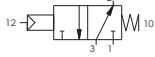

Weight gr. 330

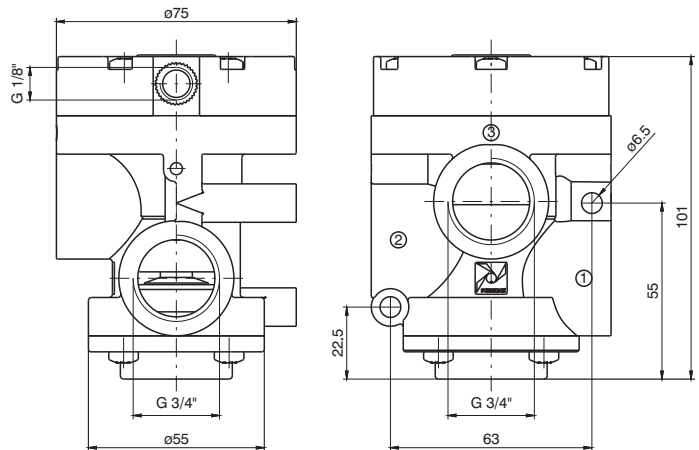

Minimum working pressure: 2,5 bar

**Solenoid valve**  
**Solenoid spring**

3/2



Weight gr. 370

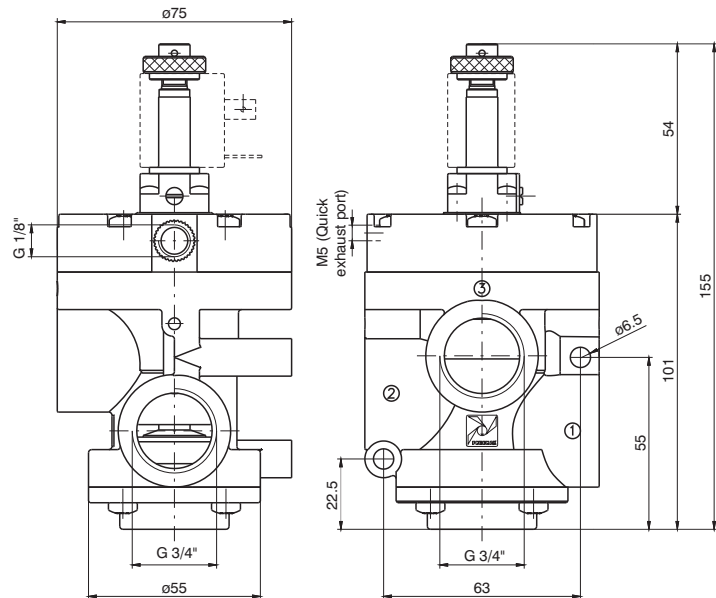

Ordering code

*Internal pilot*

*Servoassisted external pilot*

*Servoassisted external pilot  
with quick exhaust*

**T773/V.32.0.1AA.MV**

*Normally open*

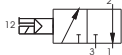

**T773/V.32.0.1.MP**

*Normally open*

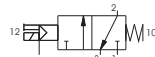

**T773/VS.32.0.1.MP**

*Normally open*

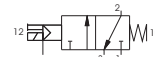

**T773/V.32.0.1AC.MV**

*Normally closed*

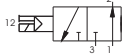

*Normally closed*

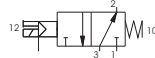

*Normally closed*

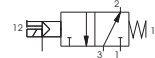

Minimum working pressure: 2.5 bar

Operational characteristics	Fluid	Operating temperature		Orifice Size	Working port size	Pilot ports size
	Vacuum	min.	max.			
		-5°C	+50°C	mm 20	G 3/4"	G 1/8"

**Bistable version for Compressed air**

3/2

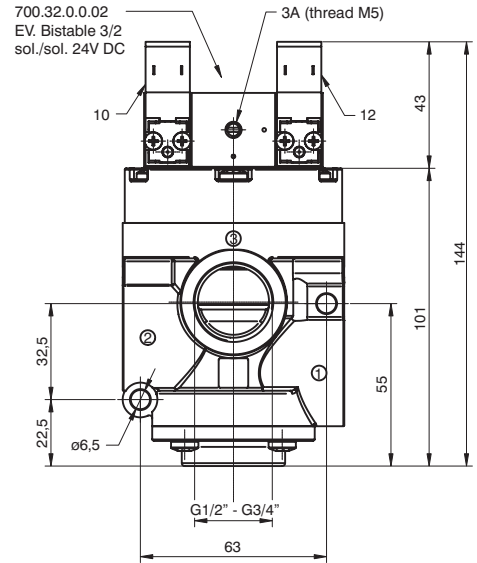
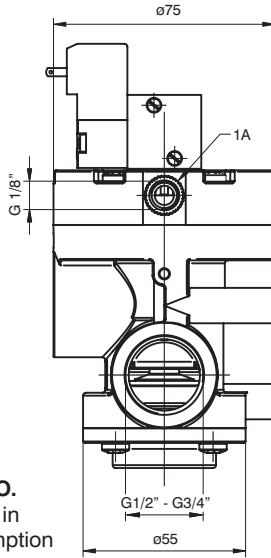

**Air - N.C.**  
1 = line in  
2 = consumption  
1 = exhaust

**Air - N.O.**  
3 = line in  
2 = consumption  
1 = exhaust

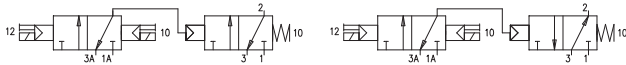

Weight gr. 550

Ordering code

G 1/2"	G 3/4"	G 1/2" (with quick exhaust)	G 3/4" (with quick exhaust)
<b>T772.32.0.1BP</b> Normally closed Normally open	<b>T773.32.0.1.BP</b> Normally closed Normally open	<b>T772S.32.0.1.BP</b> Normally closed Normally open	<b>T773S.32.0.1.BP</b> Normally closed Normally open

Operational characteristics	Fluid	Max working pressure	Min. Pilot pressure	Temperature min.	Temperature max.	Flow rate at 6 bar with Δp = 1 bar	Orifice Size	Working port size	Pilot ports size
	Filtered and lubricated or non lubricated air	10 bar	2 bar	-5° C	+50° C	G1/2": 4100 NI/min G3/4": 6400 NI/min	mm 15	G 1/2" G 3/4"	G 1/8"

**Bistable version for Vacuum**

3/2

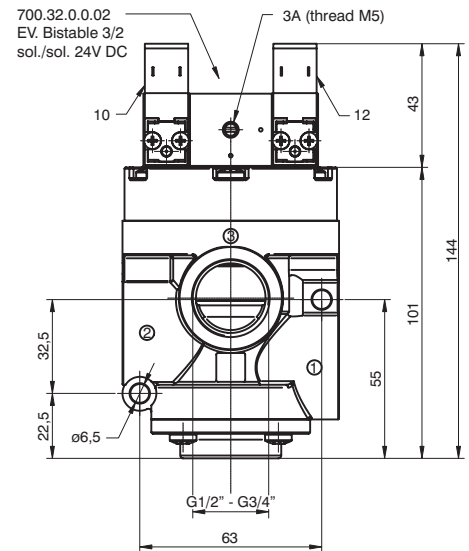
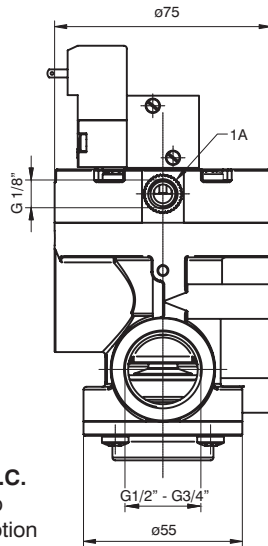

**Vacuum - N.O.**  
3 = pump  
2 = consumption  
1 = exhaust

**Vacuum - N.C.**  
1 = pump  
2 = consumption  
3 = exhaust

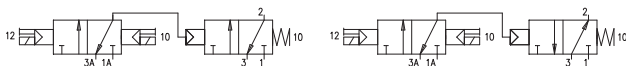

Weight gr. 550

Ordering code

G 1/2"	G 3/4"	G 1/2" (with quick exhaust)	G 3/4" (with quick exhaust)
<b>T772/V.32.0.1BP</b> Normally closed Normally open	<b>T773/V.32.0.1.BP</b> Normally closed Normally open	<b>T772/VS.32.0.1.BP</b> Normally closed Normally open	<b>T773/VS.32.0.1.BP</b> Normally closed Normally open

Operational characteristics	Fluid	Min. Pilot pressure	Temperature min.	Temperature max.	Orifice Size	Working port size	Pilot ports size
	Vacuum	2,5 bar	-5° C	+50° C	mm 15	G 1/2" G 3/4"	G 1/8"



**General**

This new range of G1" pilot and solenoid operated poppet valves represents an evolution of the current popular Zama series and of the series T772-T773 (G1/2" - 3/4").

Also for this series the main feature is the technopolimer material used to mould most of its components. The use of this material results in a versatile, lightweight and economical valve.

The new series also has other technical and functional enhancements over the existing range. Firstly, the traditional piston lip seal has been replaced with a rolling diaphragm, thereby eliminating frictional wear and tear to this seal. The new series (with the exception of certain vacuum models) also features a seal, which separates port 3 from the piston head. The inclusion of this seal has enhanced the valve's performance and allows the valve to be used as normally open (a configuration not possible in the Zama series).

Solenoid operated valves (both internal and external pilot versions) are fitted with a quick exhaust unit, which reduces the return stroke operating time by 80%. The bulk of the valves in this series use the MP type operator, the exception being internally piloted vacuum models, which use the MV operator. These operators differ from the M2 type in that they have self-tapping mounting screws for use in plastics.

Bistable versions are also available, both for air or for vacuum. These valves are fitted with a 3/2 sol-sol valve (instead of the standard pilot valve) fitted with two 15mm 24V Dc microvalves (N331.0A). Ordering codes refer to solenoid valves with MP or MV assembled on them.

**Coils are not included and have to be ordered separately (series 300, Section 1, General Catalogue), with the exception of the bistable versions which already include 24V Dc Coils (N331.0A).**

Coils  US homologated are also available (see series 300).

**Construction characteristics**

Body, operator and end cover	High resistance technopolymer
Seals and poppets	NBR
Piston and shaft	Acetal resin
Springs	AISI 302 stainless steel
Diaphragm	NBR

**Use and maintenance**

Under correct working conditions the average life of this series of valves is 10 - 15 million cycles. Lubrication is not required but correct air filtration is recommended.

It is also important to ensure that the application parameters are in line with those indicated in the technical specification of this product: pressure, temperature....

The valves, thanks to their construction design, do not require maintenance involving replacement of parts; when necessary it is possible to carefully clean and remove any dirt that might have accumulated internally.

When using the internal pilot version, both for air or vacuum, it is necessary to ensure that the downstream flow rate is lower than the inlet flow rate. Should the flow requirement match or exceed the inlet flow rate the pressure / vacuum inside the valve would drop below the minimum value necessary to actuate the pilot valve. This is a normal scenario on poppet valves as without pilot, not having a closed centre position, the valve would exhaust from port 3.

For applications where downstream flow rate requirements can match or exceed inlet flow rate use externally piloted valves.

**Air valve port layout:**

- Normally closed: 1 = LINE IN  
2 = CONSUMPTION  
3 = EXHAUST
- Normally open: 1 = EXHAUST  
2 = CONSUMPTION  
3 = LINE IN

**Vacuum valve port layout:**

- Normally closed internal pilot 1 = EXHAUST
- Normally open (servoassisted) external pilot 2 = CONSUMPTION  
3 = PUMP
- Normally open internal pilot 1 = PUMP
- Normally closed (servoassisted) external pilot 2 = CONSUMPTION  
3 = EXHAUST

**MINIMUM WORKING PRESSURE DIAGRAM (Valves for compressed air)  
PNEUMATIC/SRING AND EXTERNAL SOLENOID PILOT VERSION**

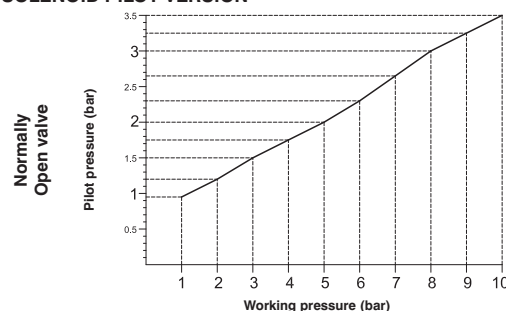
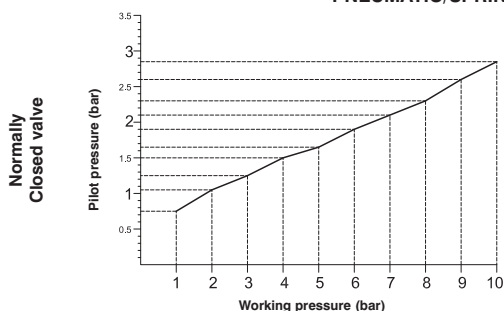

3/2

**Valve  
Pneumatic spring**

Ordering code

**T771.32.11.1**

*Normally closed*

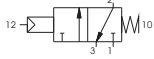

*Normally open*

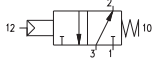

Weight gr. 480

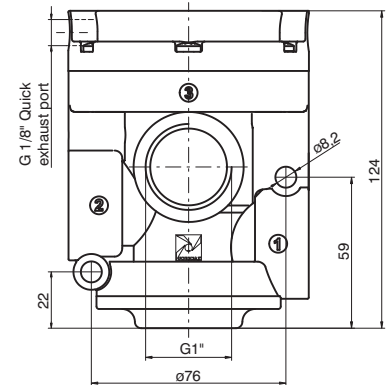
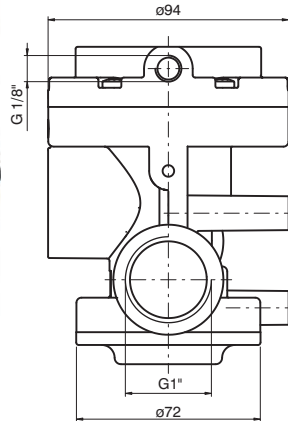

Minimum working pressure: see diagram at General page

**Solenoid valve  
Solenoid spring**

3/2



Weight gr. 520

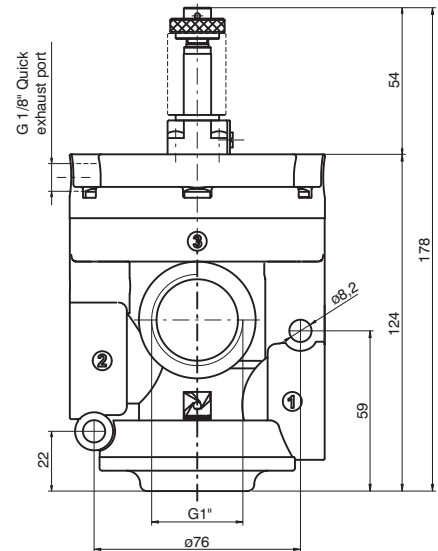
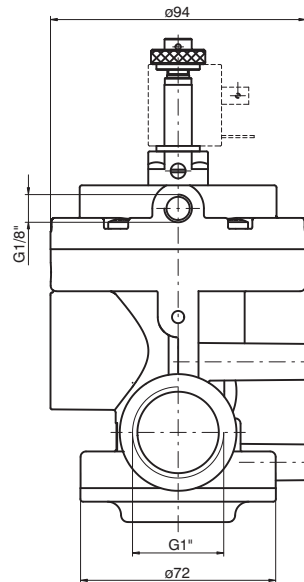

Ordering code

	<i>Internal pilot</i>	<i>Servoassisted external pilot</i>	<i>Internal pilot with quick exhaust</i>	<i>Servoassisted external pilot with quick exhaust</i>				
	<p><b>T771.32.0.1AC.MP</b> <i>Normally closed</i></p> <p><b>T771.32.0.1AA.MP</b> <i>Normally open</i></p> <p>Minimum working pressure: 2,5 bar</p>	<p><b>T771.32.0.1.MP</b></p> <p><i>Normally closed</i></p> <p><i>Normally open</i></p> <p>Minimum working pressure: see diagram at General page</p>	<p><b>T771S.32.0.1AC.MP</b> <i>Normally closed</i></p> <p><b>T771S.32.0.1AA.MP</b> <i>Normally open</i></p> <p>Minimum working pressure: 2,5 bar</p>	<p><b>T771S.32.0.1.MP</b></p> <p><i>Normally closed</i></p> <p><i>Normally open</i></p> <p>Minimum working pressure: see diagram at General page</p>				
Operational characteristics	Fluid	Max working pressure	Operating temperature min. max.		Flow rate at 6 bar with Δp = 1 bar	Orifice size	Working port size	Pilot ports size
	Filtered and lubricated or non lubricated air	10 bar	-5° C	+50° C	12.000 NI/min	mm 25	G 1"	G 1/8"

**Valve**  
**Pneumatic spring**

3/2

Ordering code

**T771/V.32.11.1**

*Normally open*



*Normally closed*

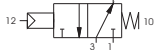

Weight gr. 480

Minimum working pressure: see diagram at General page

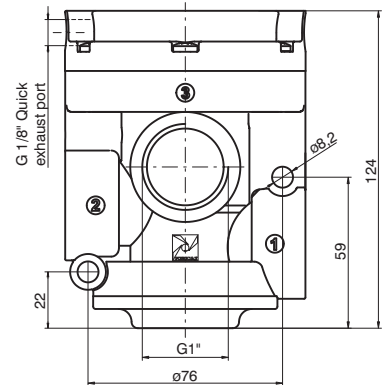
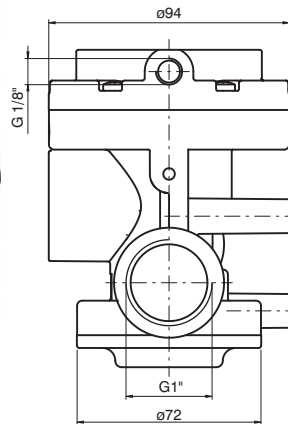

**Solenoid valve**  
**Solenoid spring**

3/2



Weight gr. 520

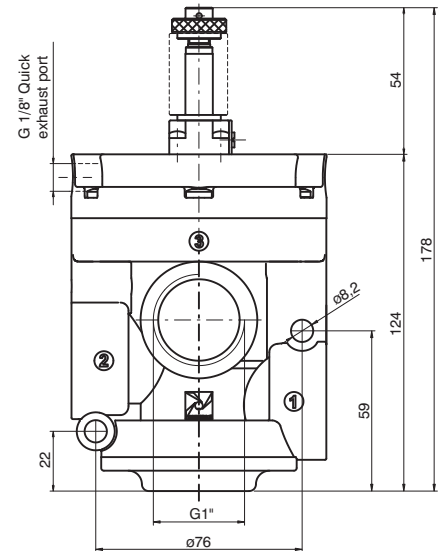
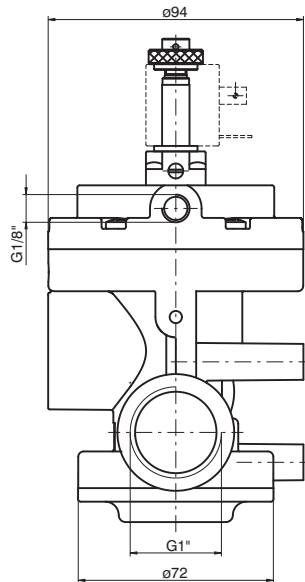

Ordering code

*Internal pilot*

*Servoassisted external pilot*

*Servoassisted external pilot  
with quick exhaust*

**T771/V.32.0.1AA.MV**  
*Normally open*

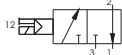

**T771/V.32.0.1.MP**

*Normally open*

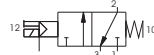

**T771/VS.32.0.1.MP**

*Normally open*

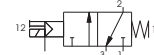

**T771/V.32.0.1AC.MV**  
*Normally closed*

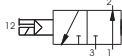

*Normally closed*

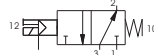

*Normally closed*

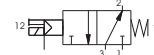

Minimum working pressure: 2 bar

Operational characteristics	Fluid	Temperature		Orifice size	Working port size	Pilot ports size
	Vacuum	min.	max.			
		-5°C	+50°C	mm 25	G 1"	G 1/8"

**Bistable version for Compressed air**



**Air - N.C.**  
 1 = line in  
 2 = consumption  
 3 = exhaust

**Air - N.O.**  
 3 = line in  
 2 = consumption  
 1 = exhaust

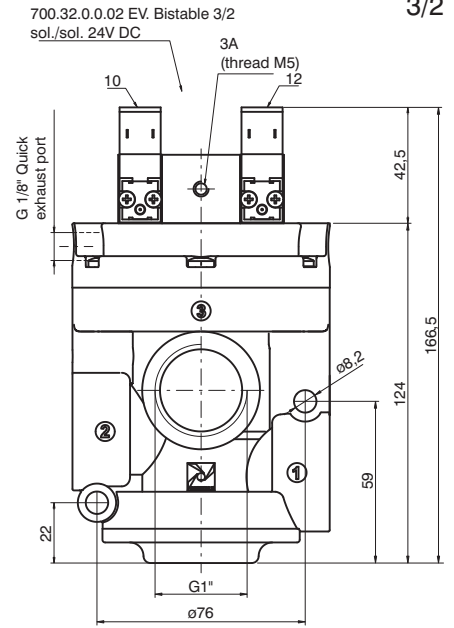
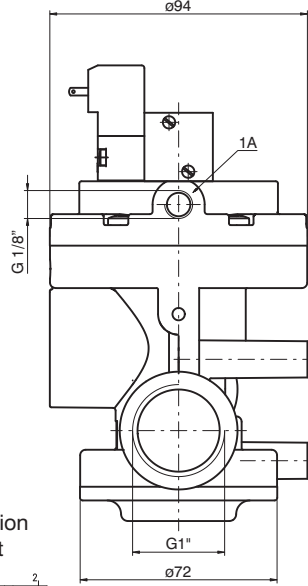
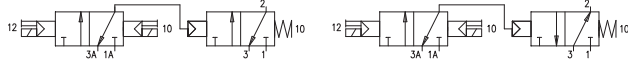

Weight gr. 680

Ordering code

**T771.32.0.1BP**  
*Normally closed / Normally open*

*with quick exhaust*  
**T771S.32.0.1.BP**  
*Normally closed / Normally open*

Operational characteristics	Fluid	Max working pressure	Minumum working pressure	Operating temperature		Flow rate at 6 bar with $\Delta p = 1\ bar$	Orifice size	Working port size	Pilot ports size
	Filtered and lubricated air	10 bar	2,5 bar	min.	max.				
				-5° C	+50° C	12.000 NI/min	mm 25	G 1"	G 1/8"

**Bistable version for Vacuum**



**Vacuum - N.O.**  
 3 = pump  
 2 = consumption  
 1 = exhaust

**Vacuum - N.C.**  
 1 = pump  
 2 = consumption  
 3 = exhaust

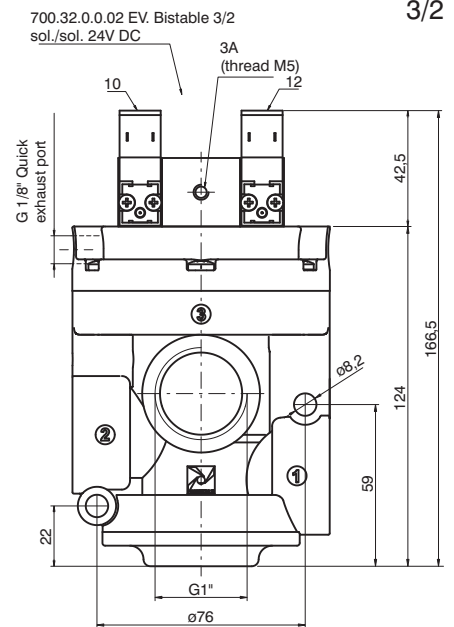
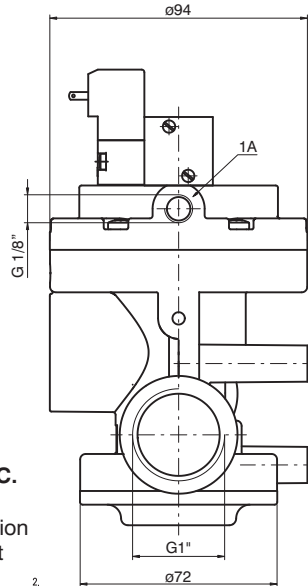
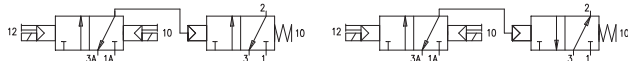

Weight gr. 680

Ordering code

**T771/V.32.0.1BP**  
*Normally closed / Normally open*

*with quick exhaust*  
**T771/VS.32.0.1.BP**  
*Normally closed / Normally open*

Operational characteristics	Fluid	Minumum working pressure	Temperature		Orifice size	Working port size	Pilot ports size
	Vacuum	2,5 bar	min.	max.			
			-5° C	+50° C	mm 25	G 1"	G 1/8"

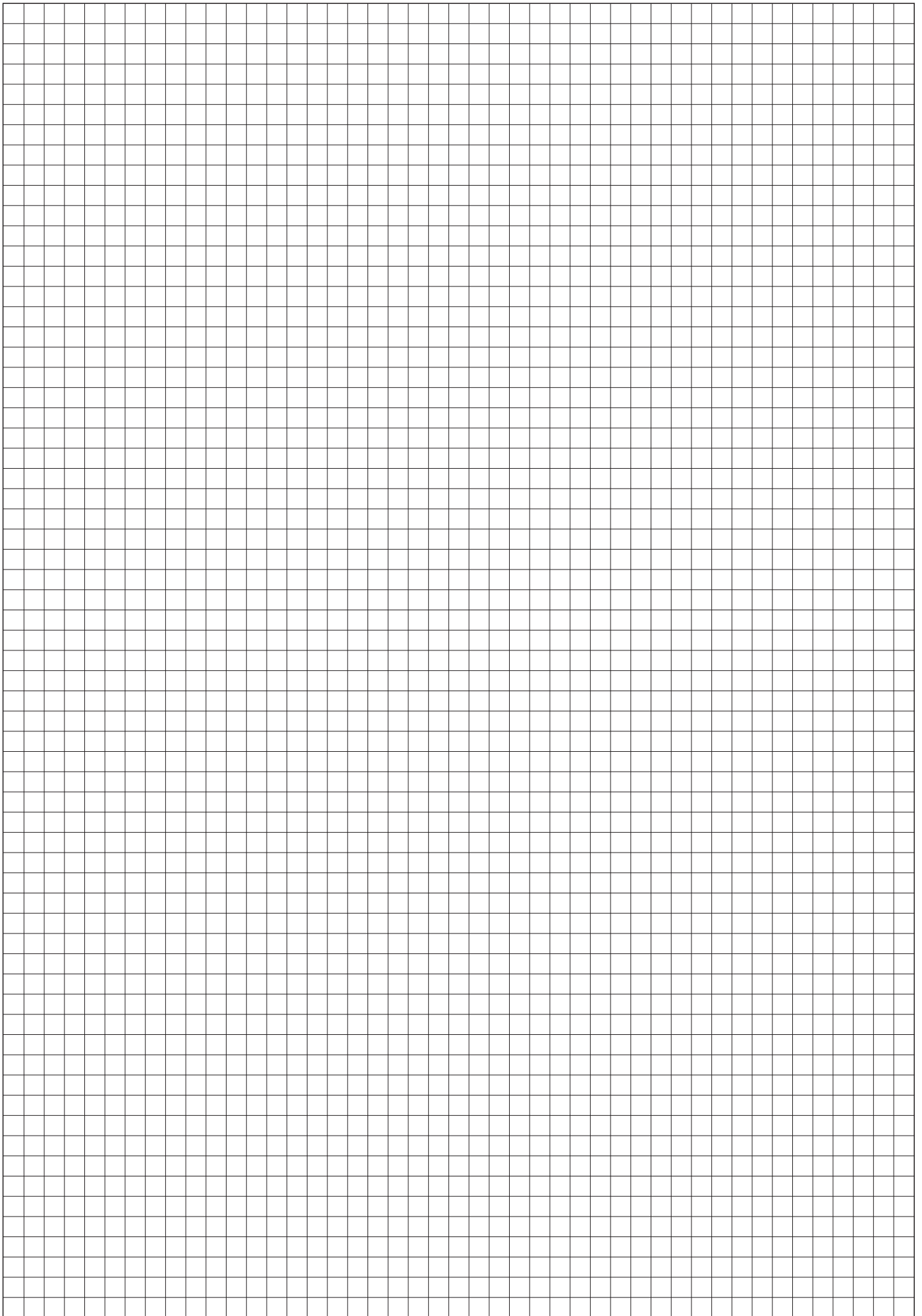



**General**

The N776 G1.1/2" series of valves and solenoid operated poppet valves is the result of the technical evolution of the 776 series. A rolling diaphragm construction has replaced the previously used piston design ensure lower frictions and longer life. Connection 3 is isolated via a dedicated seal which allow to have the N.O. version as well as the self feed for vacuum which was not available on the 776 series.

The pilot valves are the M3R (CNOMO Stile) with bistable manual override.

**Coils are not included and have to be ordered separately (see 300 series, 22mm MB coils and 30mm CNOMO MC coils).**

**Coils C RU US homologated are also available. (series 300).**

**Construction characteristics**

Body, operator and end cover:	Die casting Aluminium
Seals and poppets:	NBR oil resistant rubber
Piston:	Aluminium (for Air) - Acetylic resin (for Vacuum)
Pin guide:	Nickel plated steel
Spring:	Steel
Diaphragm:	NBR oil resistant rubber

**Use and maintenance**

Under correct working conditions the average life of this series of valves is 10 - 15 million cycles. Lubrication is not required but correct air filtration is recommended.

It is also important to ensure that the application parameters are in line with those indicated in the technical specification of this product: pressure, temperature....

The valves, thanks to their construction design, do not require maintenance involving replacement of parts; when necessary it is possible to carefully clean and remove any dirt that might have accumulated internally.

When using the internal pilot version, both for air or vacuum, it is necessary to ensure that the downstream flow rate is lower than the inlet flow rate. Should the flow requirement match or exceed the inlet flow rate the pressure / vacuum inside the valve would drop below the minimum value necessary to actuate the pilot valve. This is a normal scenario on poppet valves as without pilot, not having a closed centre position, the valve would exhaust from port 3.

For applications where downstream flow rate requirements can match or exceed inlet flow rate use externally piloted valves

<b>Air valves port layout:</b>		<b>Vacuum valves port layout:</b>	
Normally Closed:	1 = LINE IN 2 = CONSUMPTION 3 = EXHAUST	Normally Closed internal Pilot	1 = EXHAUST
		Normally Open (servoassisted) external pilot	2 = CONSUMPTION 3 = PUMP
Normally Open:	1 = EXHAUST 2 = CONSUMPTION 3 = LINE IN	Normally Open internal Pilot	1 = PUMP
		Normally Closed servoassisted) external pilot	2 = CONSUMPTION 3 = EXHAUST

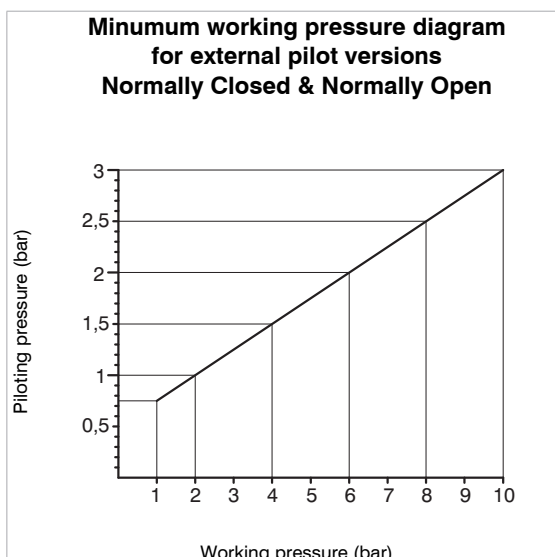

**Pneumatic - Spring**

Ordering code
<b>N776.22.11.1C</b>

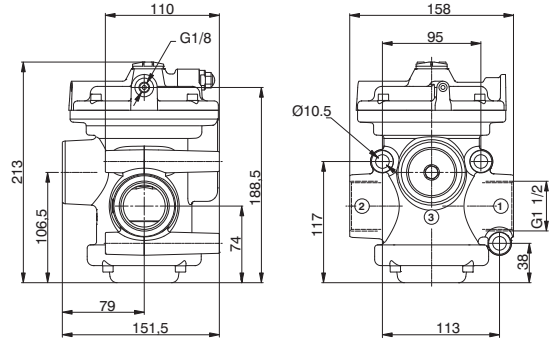

Weight gr.3560  
Normally Closed  
Minimum piloting pressure "See diagram on the General page"

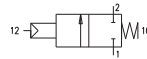

Operational characteristics	Fluid	Temperature °C	Max working pressure (bar)	Flow rate at 6 bar with Δp=1 (NI/min)	Orifice size (mm)	Working ports size	Pilot ports size
	Filtered and lubricated air or non	-5 ÷ +70	10	33500	38	G1 1/2"	G1/8"

**Solenoid - Spring**

Ordering code
<b>N776.22.0.Ⓜ.M3R</b>
FUNCTION
Ⓜ 1AC = Internal Pilot Normally Closed
Ⓜ 1C = External Pilot Normally Closed

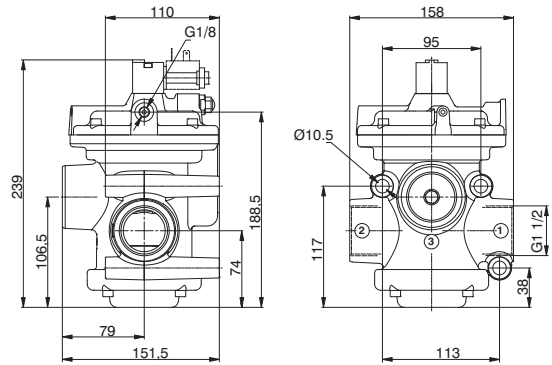

Weight gr.3620  
Minimum working pressure: Servoassisted external pilot version, "See diagram on the General page" / 3,5 bar Internal pilot version,



Operational characteristics	Fluid	Temperature °C	Max working pressure (bar)	Flow rate at 6 bar with Δp=1 (NI/min)	Orifice size (mm)	Working ports size	Pilot ports size
	Filtered and lubricated air or non	-5 ÷ +50	10	33500	38	G1 1/2"	G1/8"

**Pneumatic - Spring**

Ordering code
<b>N776.32.11.1</b>

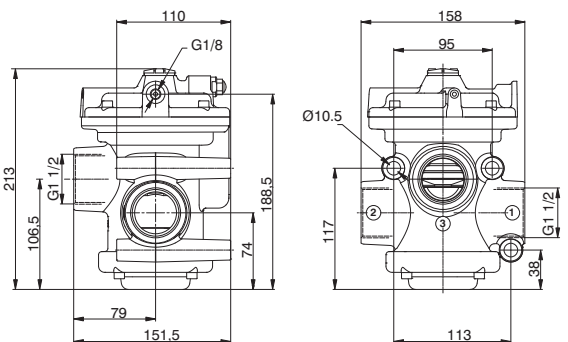

Weight gr.3550  
Normally Closed / Normally open  
Minimum piloting pressure "See diagram on the General page"



Operational characteristics	Fluid	Temperature °C	Max working pressure (bar)	Flow rate at 6 bar with Δp=1 (NI/min)	Orifice size (mm)	Working ports size	Pilot ports size
	Filtered and lubricated air or non	-5 ÷ +70	10	33500	38	G1 1/2"	G1/8"

2

Solenoid - Spring

Ordering code

**N776.32.0.F.M3R**

FUNCTION

1AC = Internal Pilot Normally Closed

**F** 1AA=Internal Pilot Normally Open

1 = External Pilot Normally Closed-Normally Open

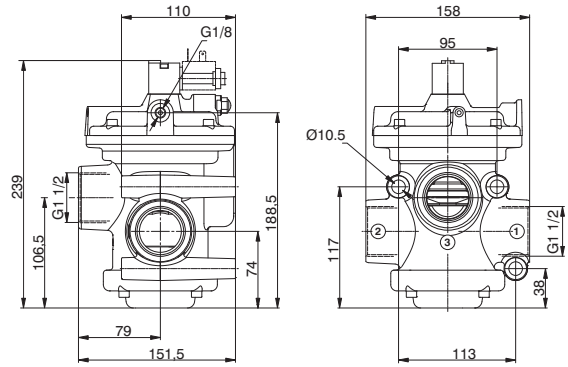

Weight gr.3610

Minimum working pressure: Servoassisted external pilot \*See diagram on the General page\* / 3,5 bar Internal pilot version,

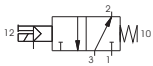
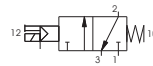
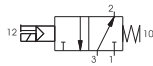
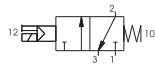

**Operational characteristics**

Fluid	Temperature °C	Max working pressure (bar)	Flow rate at 6 bar with Δp=1 (NI/min)	Orifice size (mm)	Working ports size	Pilot ports size
Filtered and lubricated air or non	-5 ÷ +50	10	33500	38	G1 1/2"	G1/8"

**Pneumatic - Spring**

Ordering code
<b>N776/V.22.11.1C</b>

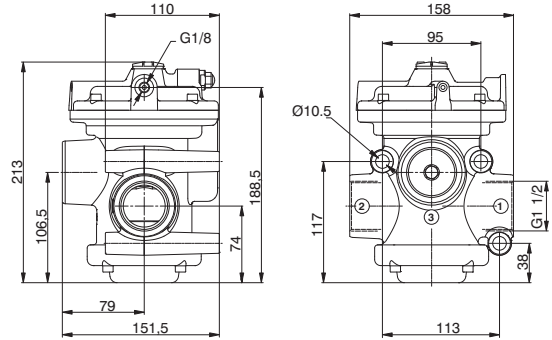

Weight gr.3178  
Normally Closed  
Minimum piloting pressure 2 bar

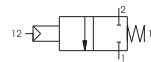

Operational characteristics	Fluid	Temperature °C	Orifice size (mm)	Working ports size	Pilot ports size
	Vacuum		-5 ÷ +70	38	G1 1/2"

**Solenoid - Spring**

Ordering code
<b>N776/V.22.0.F.M3R</b>
FUNCTION
F 1AC = Internal Pilot Normally Closed
1C = External Pilot Normally Closed

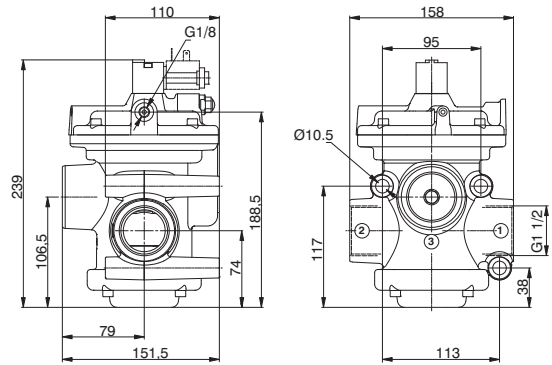

Weight gr.3238  
Minimum working pressure 2 bar



Operational characteristics	Fluid	Temperature °C	Orifice size (mm)	Working ports size	Pilot ports size
	Vacuum		-5 ÷ +50	38	G1 1/2"

**Pneumatic - Spring**

Ordering code
<b>N776/V.32.11.1</b>

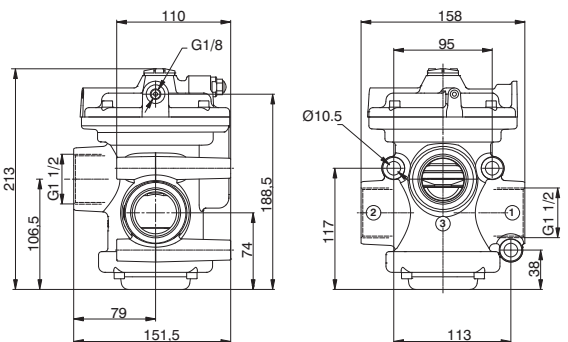

Weight gr.3168  
Normally Closed / Normally open  
Minimum piloting pressure 2 bar



Operational characteristics	Fluid	Temperature °C	Orifice size (mm)	Working ports size	Pilot ports size
	Vacuum		-5 ÷ +70	38	G1 1/2"

Solenoid - Spring

Ordering code

**N776/V.32.0.Ⓢ.M3R**

FUNCTION

1AC = Internal Pilot Normally Closed

**Ⓢ** 1AA=Internal Pilot Normally Open

1 = External Pilot Normally Closed-Normally Open

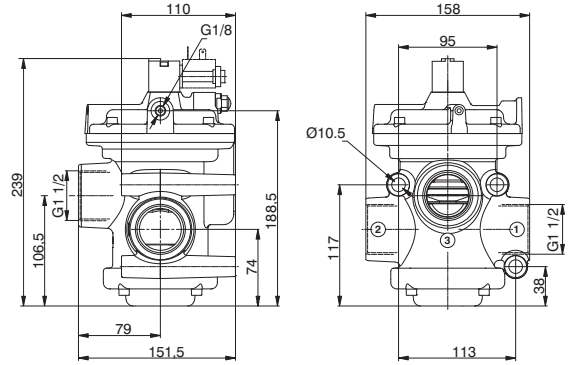

Weight gr.3228  
Minimum working pressure 2 bar

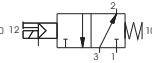
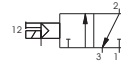
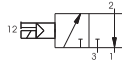
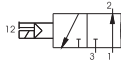

**Operational characteristics**

Fluid	Temperature °C	Orifice size (mm)	Working ports size	Pilot ports size
Vacuum	-5 ÷ +50	38	G1 1/2"	G1/8"

2

## General

Pad Valves offer a reliable and economic solution to fluid control.

The valve is manufactured with a 2 way Bronze body and actuated pneumatically using either a single or double acting compact cylinder which can be rotated 360°.

Versions are available with NBR, FPM or PTFE valve seals.

The barrel profile allows the use of magnetic sensors code "1500.\_", "RS.\_", "HS.\_", for slots "A" type.  
(see the Pneumax General catalogue, chapter 4).

## Construction characteristics

Rear eye, Piston and Rod bushing	Anodized aluminium
Cylinder	Aluminium alloy Anodized
Spring	Zinc plated steel
Pneumatic cylinder seals	NBR (FPM for variants with seals in contact with fluid in FPM or PTFE)
Seals in contact with fluid	NBR, FPM, PTFE
Piston rod	Chromed stainless steel
Bushing, Bushing pad, Nut pad	Brass

## Working characteristics

Pneumatic cylinder fluid	Filtered and lubricated air or non
Valve fluid	Fluid compatible with gasket compounds available
Maximum working pressure (bar)	10
Temperature °C, non magnetic piston, NBR seals	-5 / + 70
non magnetic piston, FPM seals	-5 / + 150
non magnetic piston, PTFE seals	-5 / + 150
magnetic piston, NBR, FPM, PTFE seals	-5 / + 70

"T" body version Pad valves

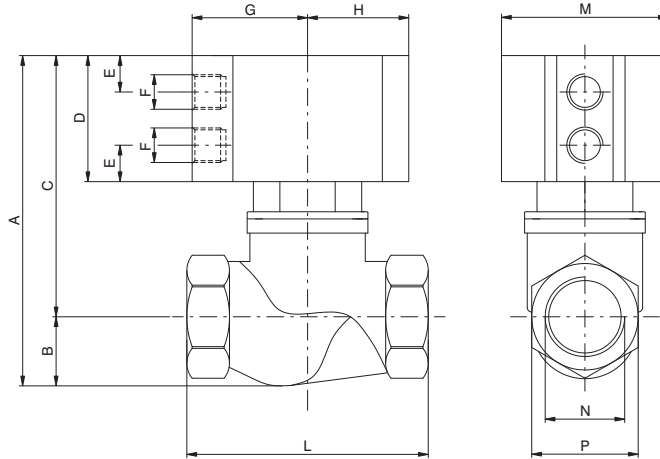

Ordering code  
**PVA.B.A.P.T.C.S**

- ACTING
- A** DE=Double acting
- SC=Normally closed
- SA=Normally open
- PISTON
- P** N=Non magnetic
- M= Magnetic
- CONNECTIONS
- A=G1/4"
- B=G3/8"
- C=G1/2"
- C** D=G3/4"
- E=G1"
- F=G1 1/4"
- G=G1 1/2"
- H=G2"
- SEALS
- S** N=NBR
- V=FPM
- F=PTFE

TABLE OF DIMENSIONS

Connection (N)	Non magnetic version			Magnetic version											TECHNICAL DATA		
	A	C	D	A	C	D	B	E	F	G	H	L	M	P	Actuator (Ø)	Nominal Valve (Ø)	Weight (gr.)
G1/4"	93,5	77,5	41	97,5	81,5	45	16	10,25	G1/8"	32,5	28,5	64	47	25	Ø40	Ø13,5	350
G3/8"	93,5	77,5	41	97,5	81,5	45	16	10,25	G1/8"	32,5	28,5	64	47	25	Ø40	Ø15	350
G1/2"	93,5	78	41	99,5	82	45	17,5	10,25	G1/8"	32,5	28,5	68	47	30	Ø40	Ø13,5	400
G3/4"	105	83	41	113	90	48	22	11,25	G1/8"	44	40	79	70	36	Ø63	Ø20,5	850
G1"	117	89	41	125	101	53	28	11,25	G1/8"	44	40	94	70	44	Ø63	Ø25	1100
G1 1/4"	131	103	48	136	108	53	28	11,25	G1/8"	44	40	110	70	55	Ø63	Ø30	1400
G1 1/2"	154	118	57	166	130	69	36	13,75	G1/8"	56	49	120	90	60	Ø80	Ø38	2100
G2"	169	124	57	181	136	69	45	13,75	G1/8"	56	49	140	90	73	Ø80	Ø49,5	3000

Pad valves, 2-ways, are a reliable and economic solution to control fluid. Pneumatically actuated by a compact double or single acting cylinder with 360° revolving connections. Standard seals in contact with fluid are made in NBR, FPM or PTFE. The barrel profile allows the use of Pneumax magnetic sensors series 1500 (see the Pneumax General catalogue, chapter 4).

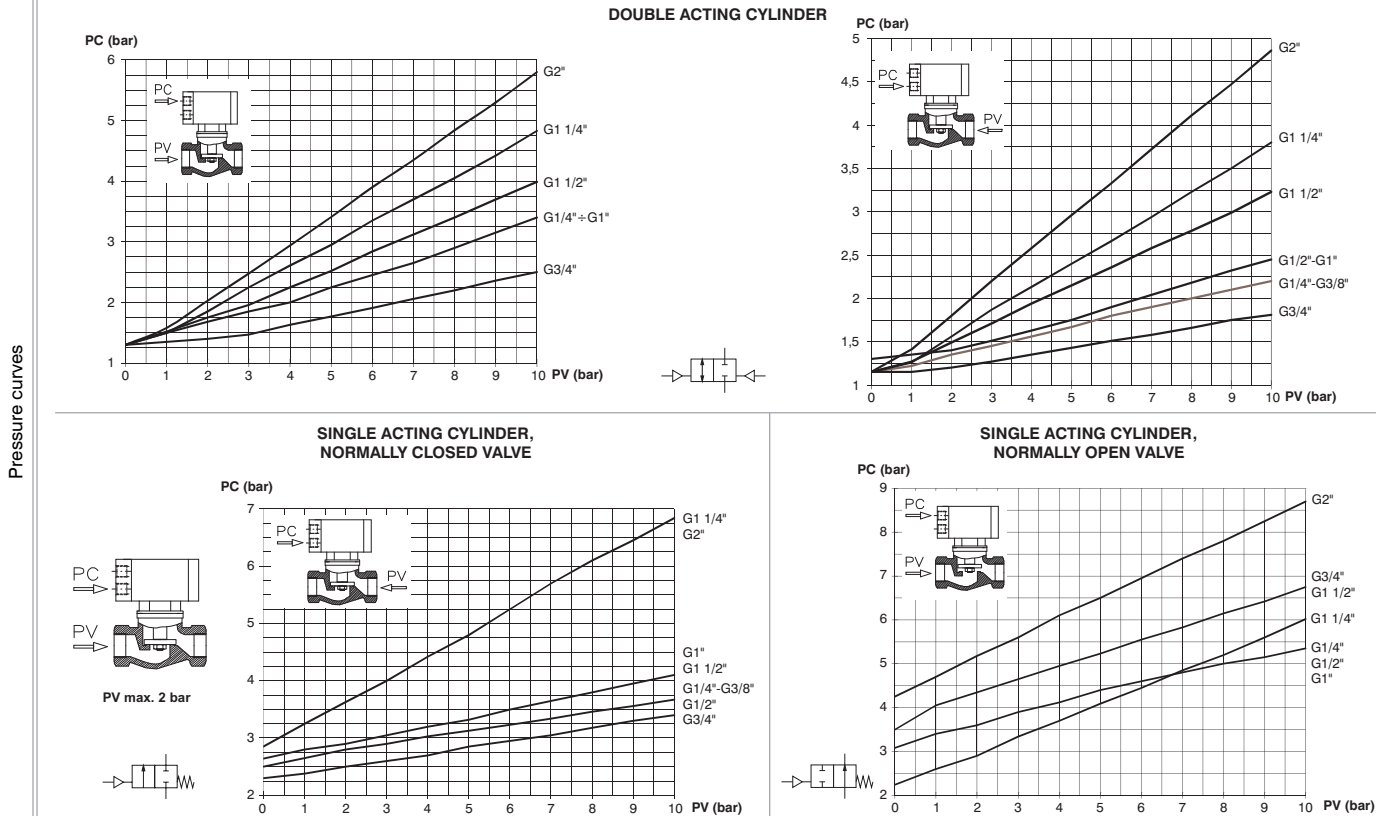

Operational characteristics

- Rear eye, Piston and Rod bushing = Anodized aluminium
- Cylinder = Aluminium alloy Anodized
- Spring = Zinc plated steel
- Seals = NBR, FPM, PTFE
- Piston rod = Chromed stainless steel
- Bushing, Bushing pad, Nut pad = Brass

Technical characteristics

Fluid	Filtered and lubricated air or non
Maximum working pressure (bar)	10
Temperature °C (non magnetic piston, NBR seals)	-5 / + 70
Temperature °C (non magnetic piston, FPM seals)	-5 / + 150
Temperature °C (non magnetic piston, PTFE seals)	-5 / + 150
Temperature °C (magnetic piston, NBR, FPM, PTFE seals)	-5 / + 70

"Y" body version Pad valves

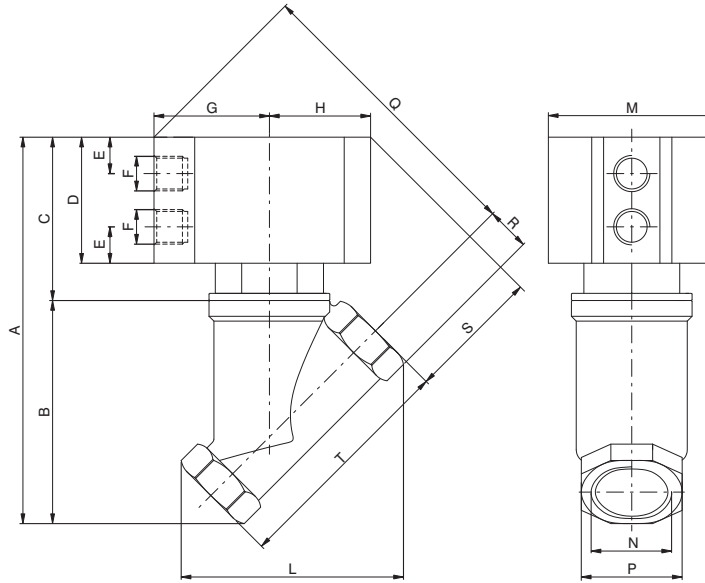

Ordering code

PVA.B.A.P.Y.C.S

- ACTING
- A** DE=Double acting
- SC=Normally closed
- SA=Normally open
- PISTON
- P** N=Non magnetic
- M= Magnetic
- CONNECTIONS
- A=G1/4"
- B=G3/8"
- C=G1/2"
- C** D=G3/4"
- E=G1"
- F=G1 1/4"
- G=G1 1/2"
- H=G2"
- SEALS
- S** N=NBR
- V=FPM
- F=PTFE

TABLE OF DIMENSIONS

Connection (N)	Non magnetic version					Magnetic version					TECHNICAL DATA												
	A	C	D	Q	S	A	C	D	Q	S	B	E	F	G	H	L	M	P	R	T	Actuator (Ø)	Nominal Valve (Ø)	Weight (gr.)
G1/4"	121	71	45	95	51	124	74	48	97	53	50	10,3	G1/8"	32,5	28,5	52	47	21	10,5	50	Ø40	Ø13	350
G3/8"	121	71	45	95	51	124	74	48	97	53	50	10,3	G1/8"	32,5	28,5	52	47	21	10,5	50	Ø40	Ø13	350
G1/2"	127	71	45	97	54	130	74	48	99	56	56	10,3	G1/8"	32,5	28,5	57	47	27	13,5	56	Ø40	Ø13	400
G 3/4"	148	80	48	119	66	201	133	104	175	92	68	11,3	G1/8"	44	40	70	70	32	16	66	Ø63	Ø18	850
G1"	159	75	48	123	75	215	131	104	175	92	84	11,3	G1/8"	44	40	82	70	38	19	78	Ø63	Ø21,5	850
G1 1/4"	184	91	65	140	70	231	138	112	172	96	93	11,3	G1/8"	44	40	105	70	47	23,5	101	Ø63	Ø30	1200
G1 1/2"	180	99	81	173	85	255	129	111	187	107	126	13,8	G1/8"	56	49	125	90	55	27,5	113	Ø80	Ø36	2000
G2"	246	106	88	182	88	269	129	111	203	109	140	13,8	G1/8"	56	49	136	90	68	34	125	Ø80	Ø46	2300

Pad valves, 2-ways, are a reliable and economic solution to control fluid. Pneumatically actuated by a compact double or single acting cylinder with 360° revolving connections. Standard seals in contact with fluid are made in NBR, FPM or PTFE. The barrel profile allows the use of Pneumax magnetic sensors series 1500 (see the Pneumax General catalogue, chapter 4).

DOUBLE ACTING CYLINDER

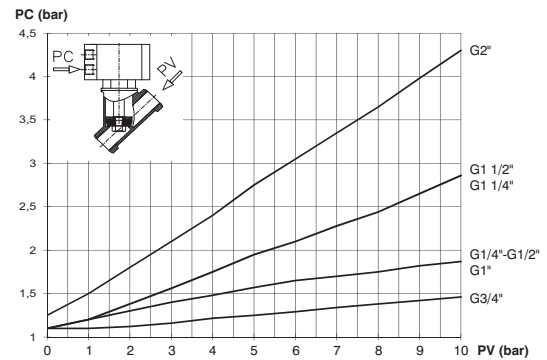
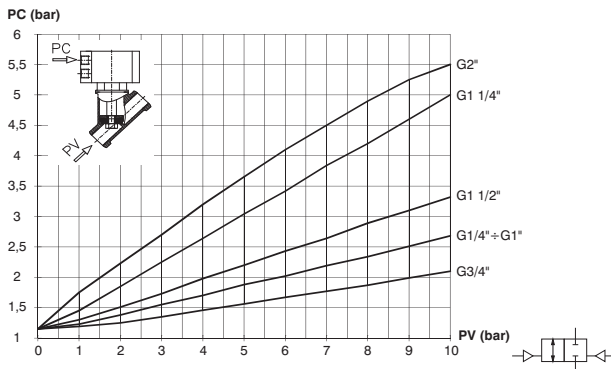

SINGLE ACTING CYLINDER, NORMALLY CLOSED VALVE

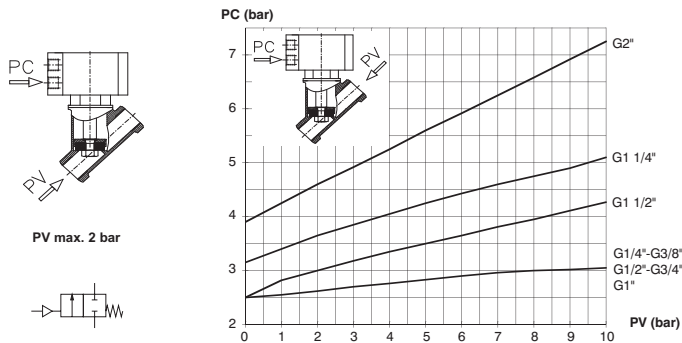

SINGLE ACTING CYLINDER, NORMALLY OPEN VALVE

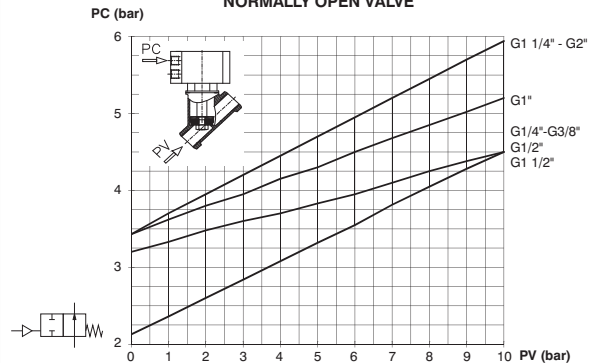

Operational characteristics

- Rear eye, Piston and Rod bushing = Anodized aluminium
- Cylinder = Aluminium alloy Anodized
- Spring = Zinc plated steel
- Seals = NBR, FPM, PTFE
- Piston rod = Chromed stainless steel
- Bushing, Bushing pad, Nut pad = Brass

Technical characteristics

Fluid	Filtered and lubricated air or non
Maximum working pressure (bar)	10
Temperature °C (non magnetic piston, NBR seals)	-5 / + 70
Temperature °C (non magnetic piston, FPM seals)	-5 / + 150
Temperature °C (non magnetic piston, PTFE seals)	-5 / + 150
Temperature °C (magnetic piston, NBR, FPM, PTFE seals)	-5 / + 70

2

3/2	<b>Solenoid - Spring</b>	Ordering code	<b>Solenoid - Spring</b>	5/2			
  		<b>514/N.0.1.M2</b>	  				
		<table border="1" style="width: 100%; border-collapse: collapse;"> <tr> <td style="text-align: center;">T</td> <td>TYPE</td> </tr> <tr> <td></td> <td>32 = 3 ways</td> </tr> <tr> <td></td> <td>52 = 5 ways</td> </tr> </table>			T	TYPE	
T	TYPE						
	32 = 3 ways						
	52 = 5 ways						
Weight gr. 390 Minimum working pressure 2,5 bar				Weight gr. 450 Minimum working pressure 2,5 bar			
<b>Operational characteristic</b>		Fluid	Max working pressure (bar)	Temperature °C	Flow rate at 6 bar with Δp=1 (NI/min)	Orifice size (mm)	Working ports size
		Filtered and lubricated air	10 bar	Min. -5°C Max. +50°C	1030 NI/min	mm 7	G 1/4"

3/2	<b>Solenoid - Differential</b>	Ordering code	<b>Solenoid - Differential</b>	5/2			
  		<b>514/N.0.12.M2</b>	  				
		<table border="1" style="width: 100%; border-collapse: collapse;"> <tr> <td style="text-align: center;">T</td> <td>TYPE</td> </tr> <tr> <td></td> <td>32 = 3 ways</td> </tr> <tr> <td></td> <td>52 = 5 ways</td> </tr> </table>			T	TYPE	
T	TYPE						
	32 = 3 ways						
	52 = 5 ways						
Weight gr. 390 Minimum working pressure 2,5 bar				Weight gr. 450 Minimum working pressure 2,5 bar			
<b>Operational characteristic</b>		Fluid	Max working pressure (bar)	Temperature °C	Flow rate at 6 bar with Δp=1 (NI/min)	Orifice size (mm)	Working ports size
		Filtered and lubricated air	10 bar	Min. -5°C Max. +50°C	1030 NI/min	mm 7	G 1/4"

3/2	<b>Solenoid - Solenoid</b>	Ordering code	<b>Solenoid - Solenoid</b>	5/2			
  		<b>514/N.0.0.M2</b>	  				
		<table border="1" style="width: 100%; border-collapse: collapse;"> <tr> <td style="text-align: center;">T</td> <td>TYPE</td> </tr> <tr> <td></td> <td>32 = 3 ways</td> </tr> <tr> <td></td> <td>52 = 5 ways</td> </tr> </table>			T	TYPE	
T	TYPE						
	32 = 3 ways						
	52 = 5 ways						
Weight gr. 390 Minimum working pressure 2,5 bar				Weight gr. 450 Minimum working pressure 2,5 bar			
<b>Operational characteristic</b>		Fluid	Max working pressure (bar)	Temperature °C	Flow rate at 6 bar with Δp=1 (NI/min)	Orifice size (mm)	Working ports size
		Filtered and lubricated air	10 bar	Min. -5°C Max. +50°C	1030 NI/min	mm 7	G 1/4"



4/2  
5/2

2

**Pneumatic - Differential / Pneumatic - Pneumatic / Pneumatic - Spring**

Ordering code	
<b>T514.1.00.F</b>	
TYPE	
<b>1</b>	42 = 4 ways
	52 = 5 ways
FUNCTION	
<b>F</b>	16 = Pneumatic - Differential
	18 = Pneumatic - Pneumatic
	19 = Pneumatic - Spring

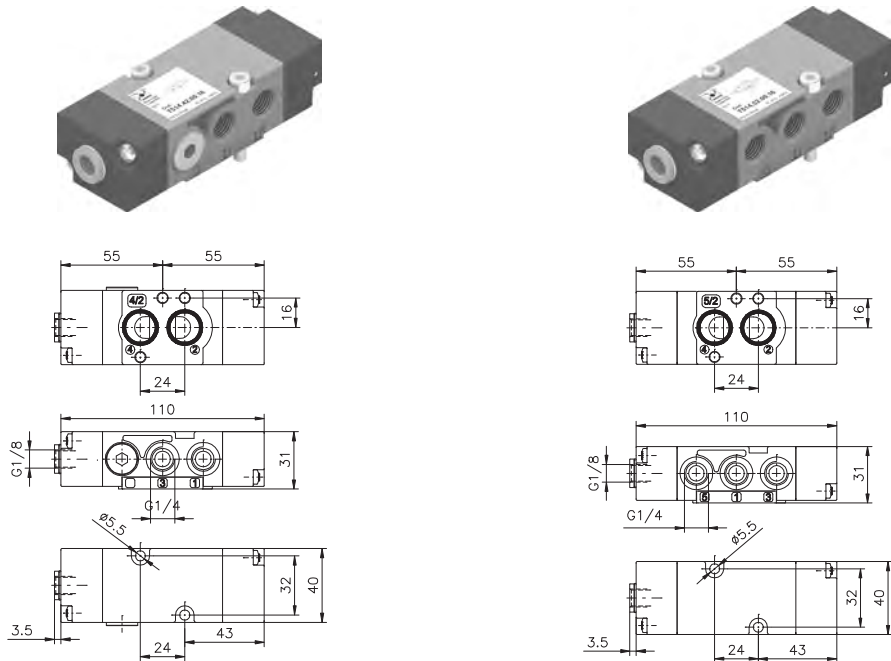

Weight gr. 140  
Minimum pilot pressure  
2,5 bar

Maximum fixing torque for fittings 9 N/m

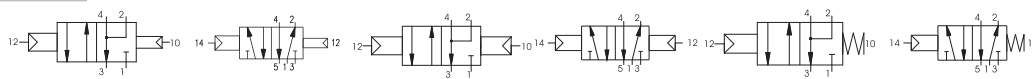

Operational characteristic	Fluid	Max working pressure (bar)	Temperature °C		Flow rate at 6 bar with Δp=1 (NI/min)	Orifice size (mm)	Working ports size
	Filtered and lubricated air	10 bar	Min. -5°C	Max. +50°C	1100 NI/min	mm 8	G 1/4"

**Solenoid - Solenoid**

4/2  
5/2

Ordering code	
<b>T514.1.00.35.V</b>	
TYPE	
<b>1</b>	42 = 4 ways
	52 = 5 ways
VOLTAGE	
	B04 = 12 VDC
	B05 = 24 VDC
<b>V</b>	B09 = 24 VDC (2W)
	B56 = 24V (50-60 Hz)
	B57 = 110V (50-60 Hz)
	B58 = 220V (50-60 Hz)

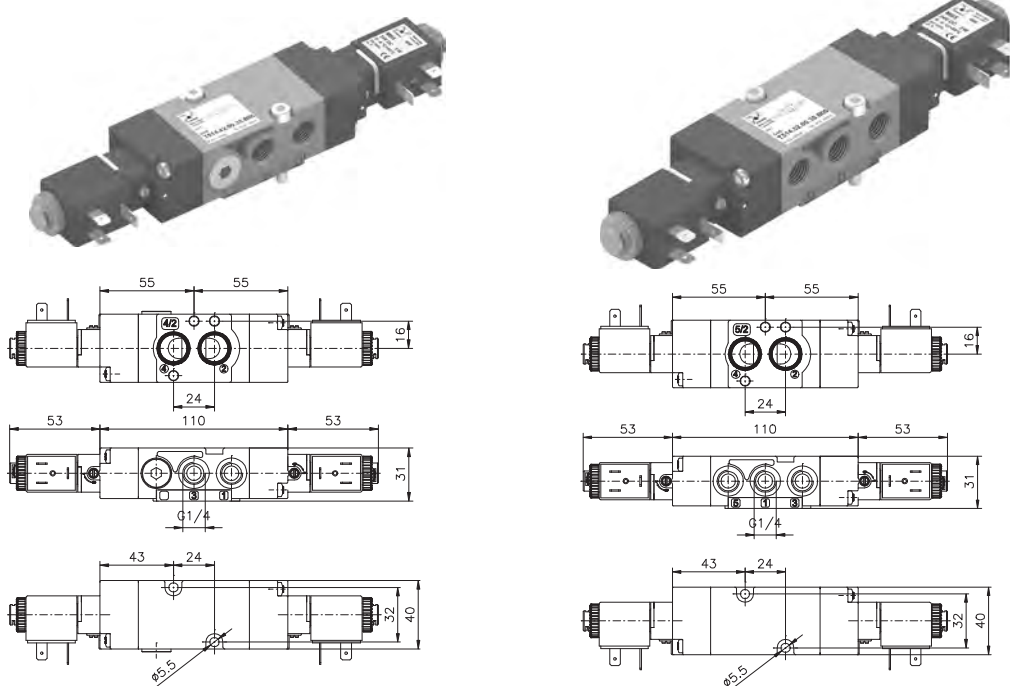

Weight gr. 250  
Minimum pilot pressure 2,5 bar  
Maximum fixing torque for fittings 9 N/m



Operational characteristic	Fluid	Max working pressure (bar)	Temperature °C		Flow rate at 6 bar with Δp=1 (NI/min)	Orifice size (mm)	Working ports size
	Filtered and lubricated air	10 bar	Min. -5°C	Max. +50°C	1100 NI/min	mm 8	G 1/4"

Solenoid - Differential / Solenoid - Spring

4/2  
5/2

Ordering code

**T514.1.00.F.V**

TYPE

- 42 = 4 ways
- 52 = 5 ways

FUNCTION

- 36 = Solenoid - Differential
- 39 = Solenoid - Spring

VOLTAGE

- B04 = 12 VDC
- B05 = 24 VDC
- B09 = 24 VDC (2W)
- B56 = 24V (50-60 Hz)
- B57 = 110V (50-60 Hz)
- B58 = 220V (50-60 Hz)

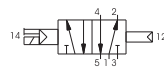
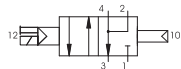
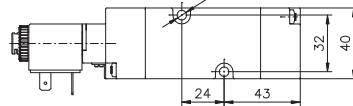
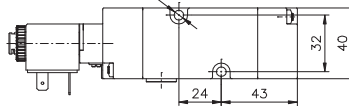
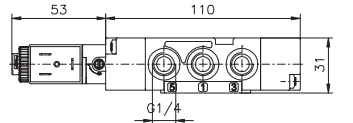
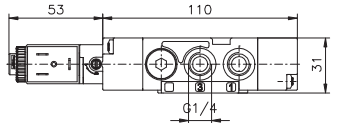
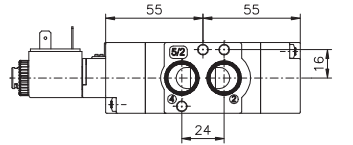
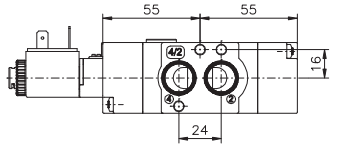

Weight gr. 200  
Minimum pilot pressure 2,5 bar  
Maximum fixing torque for fittings 9 N/m

Operational characteristic

Fluid	Max working pressure (bar)	Temperature °C		Flow rate at 6 bar with Δp=1 (NI/min)	Orifice size (mm)	Working ports size
		Min. -5°C	Max. +50°C			
Filtered and lubricated air	10 bar			1100 NI/min	mm 8	G 1/4"

Universal kit

Ordering code

**T514.92.00.F.V**

FUNCTION

- 16 = Pneumatic - Differential
- 18 = Pneumatic - Pneumatic
- 19 = Pneumatic - Spring
- 35 = Solenoid - Solenoid
- 36 = Solenoid - Differential
- 39 = Solenoid - Spring

VOLTAGE

- B04 = 12 VDC
- B05 = 24 VDC
- B09 = 24 VDC (2W)
- B56 = 24V (50-60 Hz)
- B57 = 110V (50-60 Hz)
- B58 = 220V (50-60 Hz)

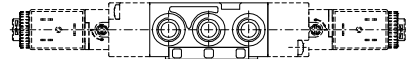
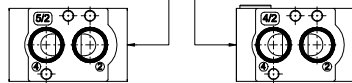
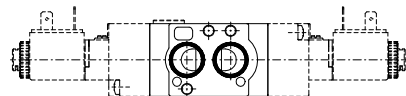

Weight gr. 170  
Minimum pilot pressure 2,5 bar  
Maximum fixing torque for fittings 9 N/m



To change a 5/2 valve into a 4/2:  
Simply replace the bottom plate with the one included in the universal kit (cod. T514.92....) and by plugging port 5

Operational characteristic

Fluid	Max working pressure (bar)	Temperature °C		Flow rate at 6 bar with Δp=1 (NI/min)	Orifice size (mm)	Working ports size
		Min. -5°C	Max. +50°C			
Filtered and lubricated air	10 bar			1100 NI/min	mm 8	G 1/4"