

SKUPP®

CYLINDERS



SK SERIES

TABLE OF CONTENT

SK64 ISO 6432.....	3
SKZP ISO 15552 PROFILE	10
SKZT ISO 15552 TIE ROD & BIG BORE	14
SKC ISO 21287 COMPACT	18
SPECIALS	23
ACCESSORIES	24

SK64

ISO 6432 MINICYLINDER

ISO 6432 cylinders with crimped covers. Available with or without magnet, with or without adjustable cushioning, single or through piston rod. Wide range of mounting accessories. Special versions are available.



TECHNICAL FEATURES

END CAPS

Die-cast aluminium

TUBES

Anodized aluminium

ROD & PISTON SEALS

Polyurethane

BUFFERS

Mechanical

ROD

Chromium plated steel

WORKING PRESSURE

1 - 10 BAR

AMBIENT TEMPERATURE

-10 °C - + 80 °C

MEDIUM TEMPERATURE

0 °C - + 40 °C

FLUIDS

Filtered and (un)lubricated air

VERSION

SM		SEM	
DA		DAP	
DM		DMP	
DMA		DMAP	

SK64	VERSION	OPTIONAL	DIAMETER	STROKE	OPTIONS
SM	Single acting magnetic	X AISI 316	8 12 16 20 25	0...2700	- Standard
SEM	Single acting spring extend, magnetic				Y YFKM rod seal
DM	Double acting magnetic				V FKM seals
DA	Double acting with adjustable cushioning, non magnetic				I Stainless steel rod AISI 304
DMA	Double acting, magnetic, with adjustable cushioning				X Stainless steel rod AISI 316L
DMP	Double acting magnetic, with through rod				NR Non-rotating
DAP	Double acting, through rod, adjustable cushioning, non magnetic				L Low friction
DMAP	Double acting, magnetic, through rod, adjustable cushioning				
DMH	Double Acting, head cut (short version), port on axis				
DMN	Double Acting, head cut (short version)				

STANDARD STROKE LENGTH

Our ISO 6432 minicylinders are in stock with stroke lengths from 25 up to 500.
Longer stroke lengths are available upon request.

THEORETICAL FORCES AT 6 BAR

Ø (MM)	THRUST FORCE (N)	TRACTION FORCE (N)
8	30	23
10	47	40
12	68	51
16	121	104
20	189	158
25	295	247

THEORETICAL SPRING FORCES

	SPRING RETURN						SPRING EXTEND					
	STROKE 10		STROKE 25		STROKE 50		STROKE 10		STROKE 25		STROKE 50	
	Min.	Max.	Min.	Max.	Min.	Max.	Min.	Max.	Min.	Max.	Min.	Max.
8	4.1	4.6	3.4	4.6	2.2	4.6	5.5	6	4.8	6	3.6	6
10	4.1	4.6	3.4	4.6	2.2	4.6	5	6.2	3.3	6.2	2.4	6.2
12	5.6	6	5.5	6	4.1	6	13	14.2	11.3	14.2	8.5	14.2
16	19.2	21.5	15.7	21.5	9.8	21.5	19	20.7	16.3	20.7	12	20.7
20	20.4	22.5	17.3	22.5	11.7	22.5	57.2	61.5	50.7	61.5	39.8	61.5
25	17.5	18.5	15.6	18.8	12.4	18.8	28.5	30.6	25.3	30.6	19.8	30.6

Value in Newton [N]

Single Acting, spring return

SK64-SM

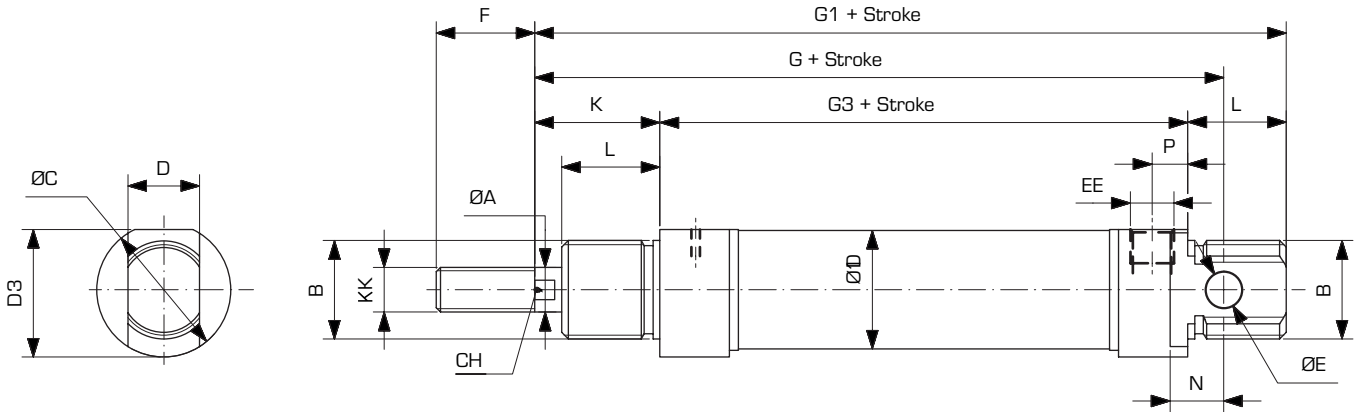

Ø	ØA	B	ØC	CH	D	ØD1	D3	ØE	EE	F	G	G1	G3	K	KK	L	N	P
8	4	M12x1.25	16	/	8	9.27	15	4	M5	12	64	74	46	16	M4x0.7	12	6	5
10	4	M12x1.25	16	/	8	11.27	15	4	M5	12	64	74	46	16	M4x0.7	12	6	5
12	6	M16x1.5	19	5	12	13.27	18	6	M5	16	75	88	48	22	M6x1	18	9	5
16	6	M16x1.5	19	5	12	17.27	18	6	M5	16	82	93	53	22	M6x1	18	9	4.5
20	8	M22x1.5	27	7	16	21.27	25.5	8	G1/8"	20	95	111	67	24	M8x1.25	20	12	8
25	10	M22x1.5	30	9	16	26.5	28.5	8	G1/8"	22	104	118	68	28	M10x1.25	22	12	8

Single Acting, spring extend

SK64-SEM

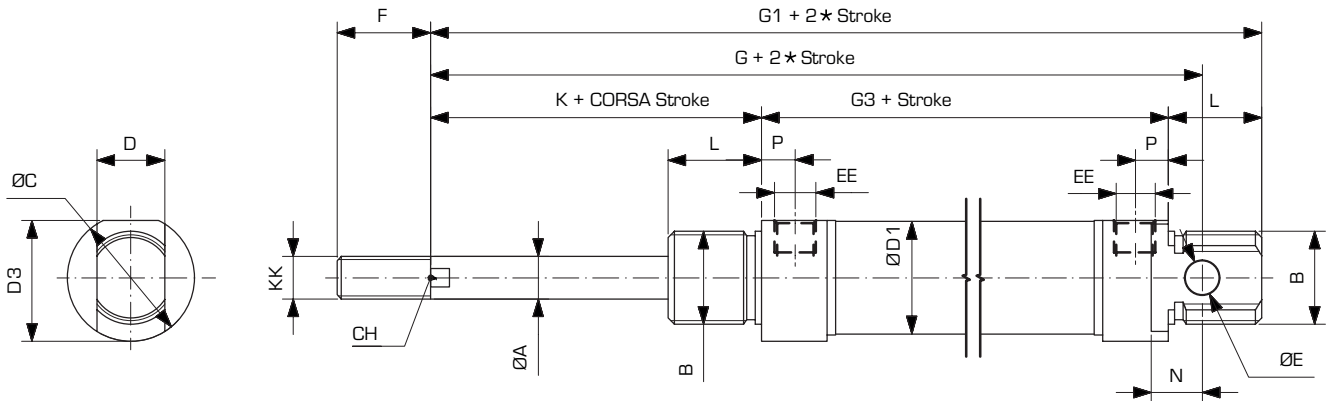

Ø	ØA	B	ØC	CH	D	ØD1	D3	ØE	EE	F	G	G1	G3	K	KK	L	N	P
8	4	M12x1.25	16	/	8	9.27	15	4	M5	12	82	92	64	16	M4x0.7	12	6	5
10	4	M12x1.25	16	/	8	11.27	15	4	M5	12	89.5	99.5	71.5	16	M4x0.7	12	6	5
12	6	M16x1.5	19	5	12	13.27	18	6	M5	16	97.5	110.5	70.5	22	M6x1	18	9	5
16	6	M16x1.5	19	5	12	17.27	18	6	M5	16	111	122	82	22	M6x1	18	9	4.5
20	8	M22x1.5	27	7	16	21.27	25.5	8	G1/8"	20	126.5	142.5	98.5	24	M8x1.25	20	12	8
25	10	M22x1.5	30	9	16	26.5	28.5	8	G1/8"	22	135.5	149.5	99.5	28	M10x1.25	22	12	8

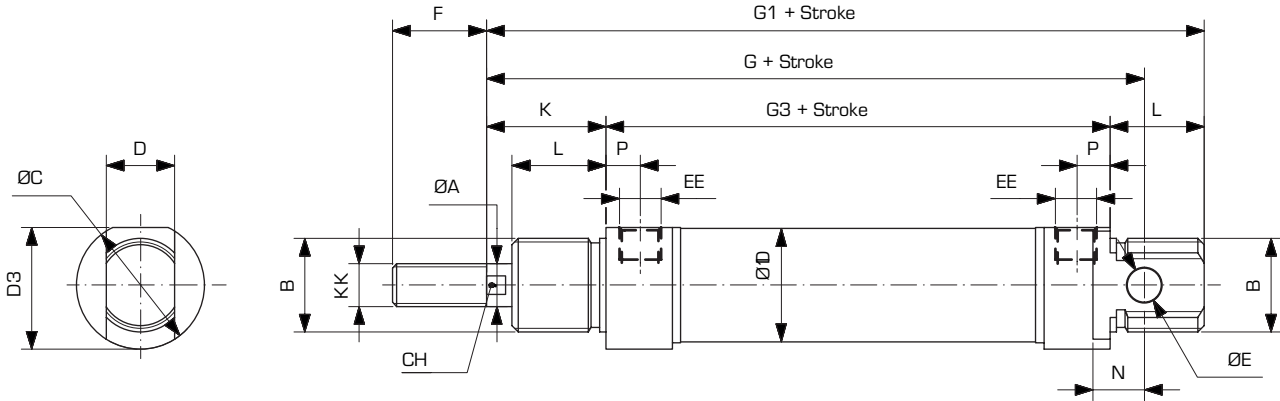

Ø	ØA	B	ØC	CH	D	ØD1	D3	ØE	EE	F	G	G1	G3	K	KK	L	N	P
8	4	M12x1.25	16	/	8	9.27	15	4	M5	12	64	74	46	16	M4x0.7	12	6	5
10	4	M12x1.25	16	/	8	11.27	15	4	M5	12	64	74	46	16	M4x0.7	12	6	5
12	6	M16x1.5	19	5	12	13.27	18	6	M5	16	75	88	48	22	M6x1	18	9	5
16	6	M16x1.5	19	5	12	17.27	18	6	M5	16	82	93	53	22	M6x1	18	9	4.5
20	8	M22x1.5	27	7	16	21.27	25.5	8	G1/8"	20	95	111	67	24	M8x1.25	20	12	8
25	10	M22x1.5	30	9	16	26.5	28.5	8	G1/8"	22	104	118	68	28	M10x1.25	22	12	8

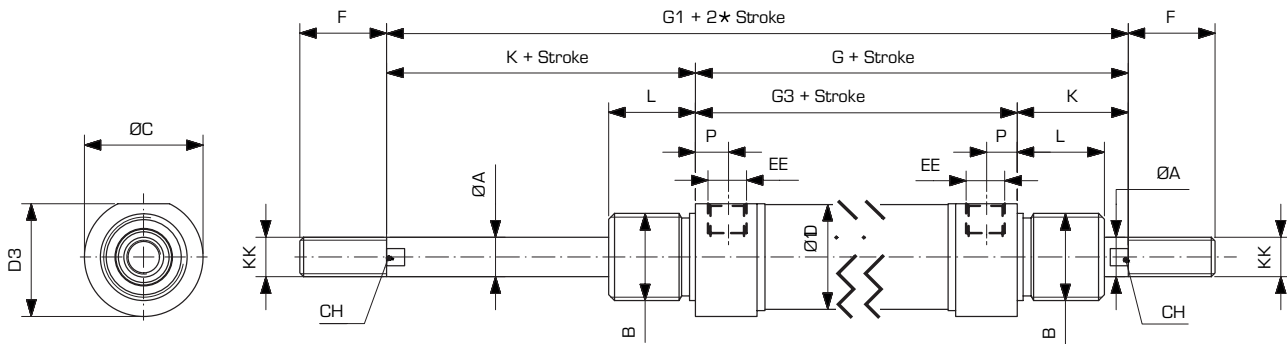

Ø	ØA	B	ØC	CH	ØD1	D3	EE	F	G	G1	G3	K	KK	L	P	CH
8	4	M12x1.25	16	/	9.27	15	M5	12	62	78	46	16	M4x0.7	12	5	10
10	4	M12x1.25	16	/	11.27	15	M5	12	62	78	46	16	M4x0.7	12	5	13
12	6	M16x1.5	19	5	13.27	18	M5	16	70	92	48	22	M6x1	18	5	17
16	6	M16x1.5	19	5	17.27	18	M5	16	75	97	53	22	M6x1	18	4.5	17
20	8	M22x1.5	27	7	21.27	25.5	G1/8"	20	91	115	67	24	M8x1.25	20	8	21
25	10	M22x1.5	30	9	26.5	28.5	G1/8"	22	96	124	68	28	M10x1.25	22	8	21

Double Acting, with cushioning

SK64-DMA

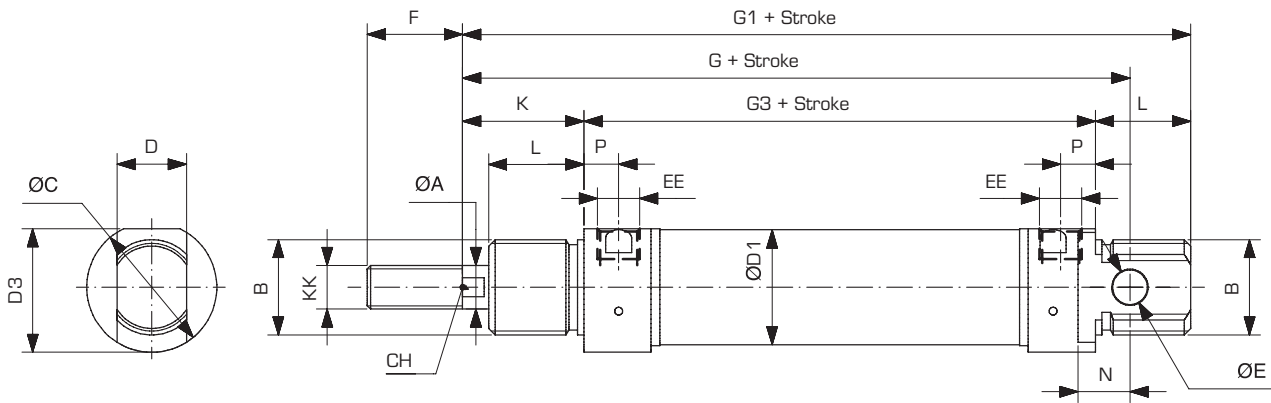

Ø	ØA	B	ØC	CH	D	ØD1	D3	ØE	EE	F	G	G1	G3	K	KK	L	N	P
16	6	M16x1.5	21	5	12	17.27	20	6	M5	16	82	93	55	22	M6x1	17	9	5.5
20	8	M22x1.5	27	7	16	21.27	25.5	8	1/8"G	20	95	111	67	24	M8x1.25	20	12	8
25	10	M22x1.5	30	9	16	26.5	28.5	8	1/8"G	22	104	118	68	28	M10x1.25	22	12	8

Double Acting, cushioned, with through rod

SK64-DMAP

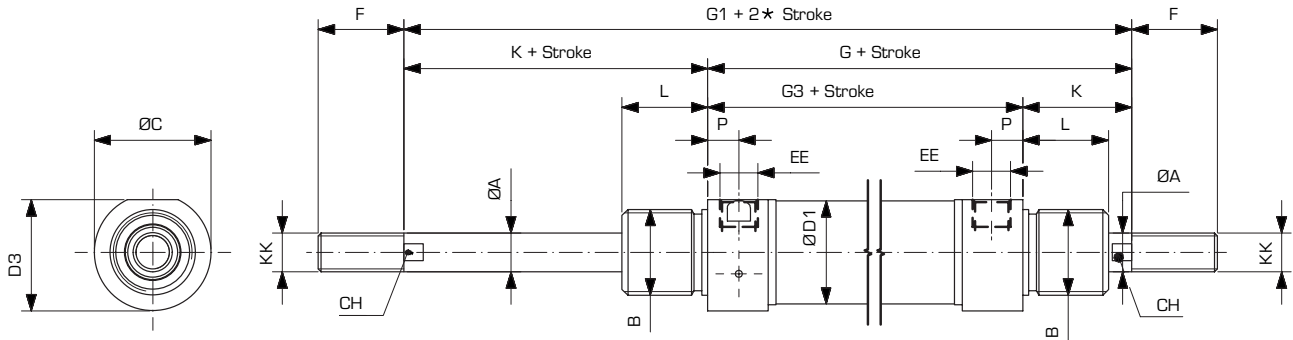

Ø	ØA	B	ØC	CH	ØD1	D3	EE	F	G	G1	G3	K	KK	L	P	L	N	P
16	6	M16x1.5	21	5	17.27	20	M5	16	76	97	55	22	M6x1	17	5.5	12	6	5
20	8	M22x1.5	27	7	21.27	25.5	1/8"G	20	91	115	67	24	M8x1.25	20	8	12	6	5
25	10	M22x1.5	30	9	26.5	28.5	1/8"G	22	96	124	68	28	M10x1.25	22	8	18	9	5

Double acting, head cut (shortened), with port on axis

SK64-DMH

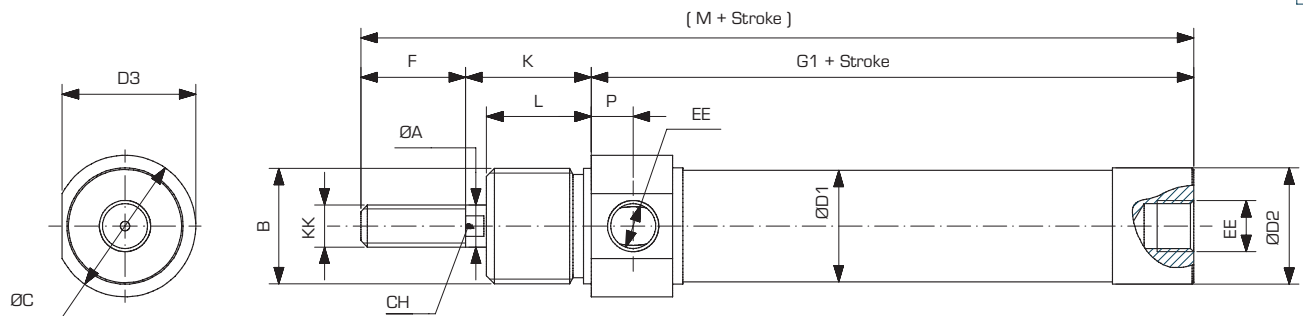

Ø	ØA	B	ØC	CH	ØD1	D3	EE	F	G	G1	G3	K	KK	L	P	L	N	P
16	6	M16x1.5	21	5	17.27	20	M5	16	76	97	55	22	M6x1	17	5.5	12	6	5
20	8	M22x1.5	27	7	21.27	25.5	1/8"G	20	91	115	67	24	M8x1.25	20	8	12	6	5
25	10	M22x1.5	30	9	26.5	28.5	1/8"G	22	96	124	68	28	M10x1.25	22	8	18	9	5

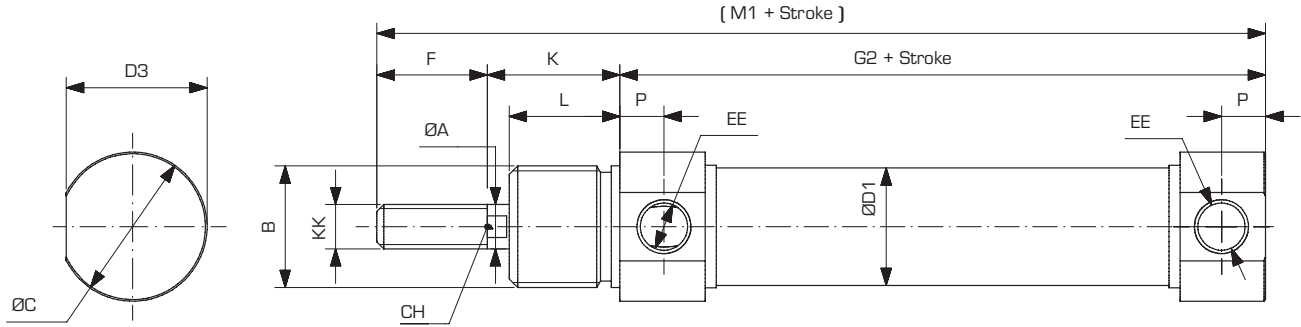

Ø	ØA	B	ØC	CH	ØD1	D3	EE	F	G2	K	KK	L	M1	P	KK	L	N	P
16	6	M16x1.5	19	5	17.27	18	M5	16	52.5	22	M6x1	18	90.5	4.5	M4x0.7	12	6	5
20	8	M22x1.5	27	7	21.27	25.5	1/8"G	20	67	24	M8x1.25	20	111	8	M4x0.7	12	6	5
25	10	M22x1.5	30	9	26.5	28.5	1/8"G	22	68	28	M10x1.25	22	118	8	M6x1	18	9	5

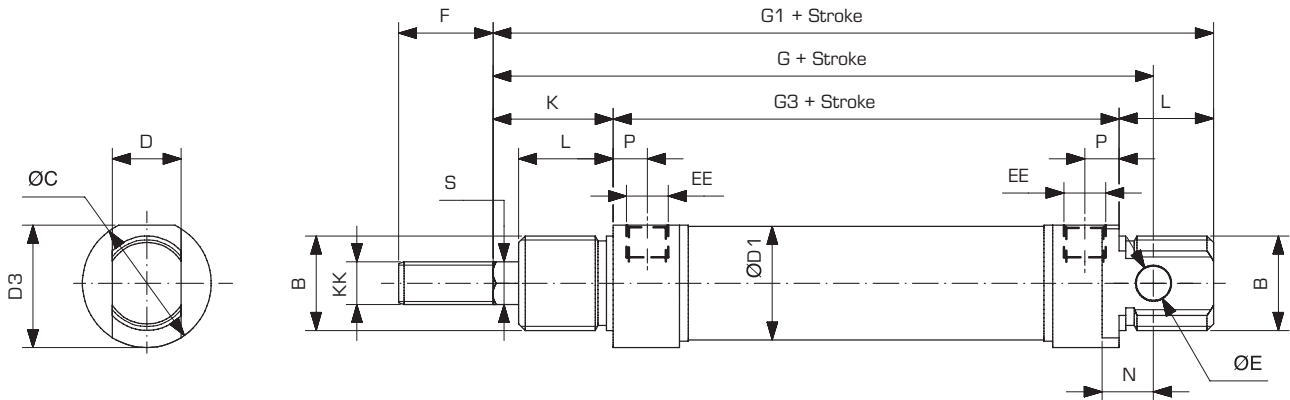

Ø	B	ØC	D	ØD1	D3	ØE	EE	F	G	G1	G3	K	KK	L	N	P	S
16	M16x1.5	19	12	17.27	18	6	M5	16	82	93	53	22	M6x1	18	9	4.5	6
20	M22x1.5	27	16	21.27	25.5	8	1/8"G	20	95	111	67	24	M8x1.25	20	12	8	8
25	M22x1.5	30	16	26.5	28.5	8	1/8"G	22	104	118	68	28	M10x1.25	22	12	8	10

SK64

ISO 6432 ACCESSORIES

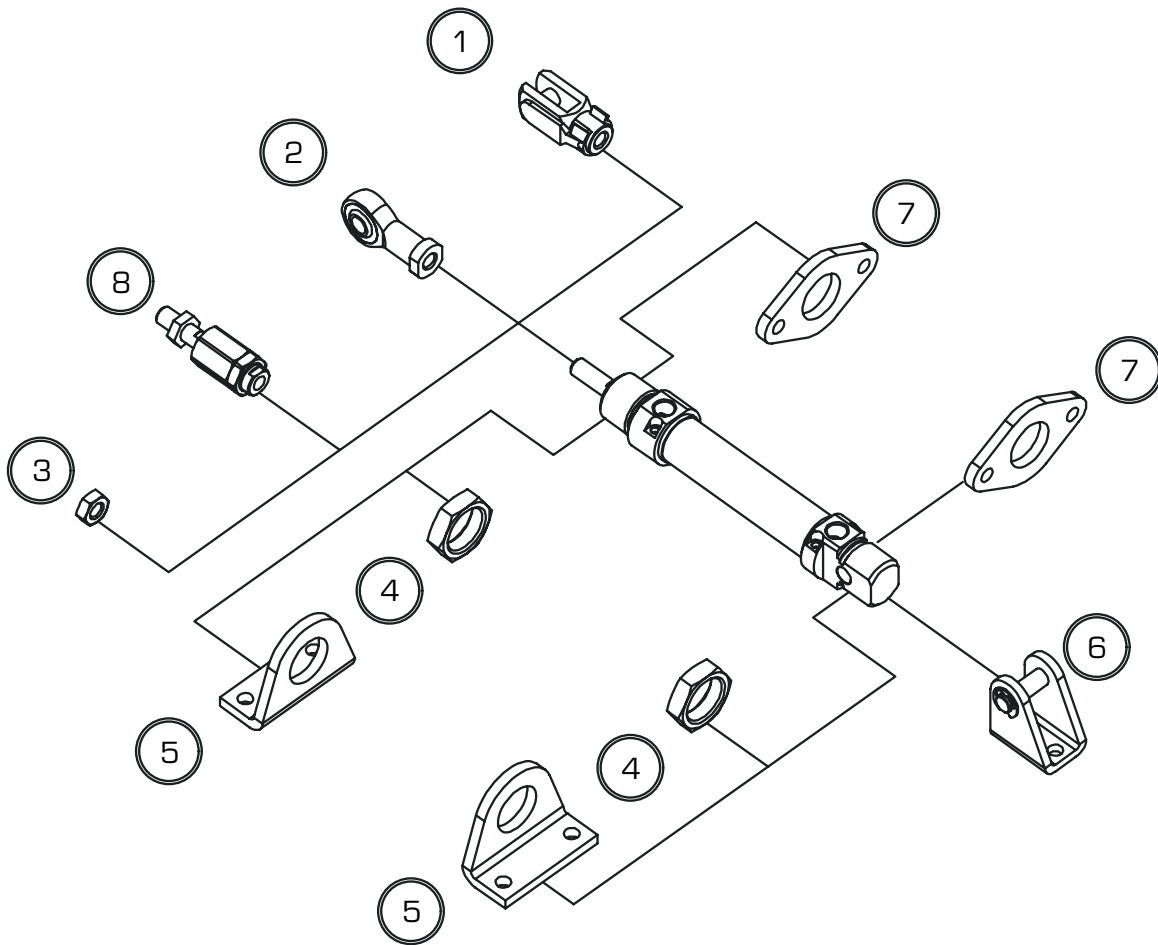

	DESCRIPTION	PROD. NR.
1	Clevis	SKAC03
2	Rod end	SKAC04
3	Piston rod nut	SKAC01
4	Cover nut	SKAC01/SKAC30
5	Foot	SKAC06
6	Hinge	SKAC05
7	Flange	SKAC07
8	Self-aligning joint	SKAC02

ISO 15552 cylinders, profiled tube version. Featuring a clean design, high resistance and mounting precision. Available with or without magnet, with or without adjustable cushioning, single or through piston rod. Also available as tie-rod version up to Ø125.



TECHNICAL FEATURES

END CAPS

Die-cast aluminium

TUBES

Anodized aluminium

ROD & PISTON SEALS

Polyurethane

BUFFERS

Mechanical

ROD

Chromium plated steel

WORKING PRESSURE

1 - 10 BAR

AMBIENT TEMPERATURE

-10 °C - + 80 °C

MEDIUM TEMPERATURE

0 °C - + 40 °C

FLUIDS

Filtered and (un)lubricated air

VERSION

SM		SEM	
DA		DAP	
DM		DMP	
DMA		DMAP	

SKZP	VERSION	OPTIONAL	DIAMETER	STROKE	OPTIONS
SM	Single acting magnetic	X AISI 316	32 40 50 63 80 100 125	0...2700	- Standard
SEM	Single acting spring extend, magnetic				Y YFKM rod seal
DM	Double acting magnetic				V FKM seals
DA	Double acting with adjustable cushioning, non magnetic				I Stainless steel rod AISI 304
DMA	Double acting, magnetic, with adjustable cushioning				X Stainless steel rod AISI 316L
DMP	Double acting magnetic, with through rod				NR Non-rotating
DAP	Double acting, through rod, adjustable cushioning, non magnetic				L Low friction
DMAP	Double acting, magnetic, through rod, adjustable cushioning				

STANDARD STROKE LENGTH

Our ISO 15552 cylinders are in stock with stroke lengths from 25 up to 500.
Longer stroke lengths are available upon request.

THEORETICAL FORCES AT 6 BAR

Ø (MM)	THRUST FORCE (N)	TRACTION FORCE (N)
32	482	414
40	754	633
50	1178	989
63	1869	1681
80	3014	2720
100	4710	4416
125	7359	6877

SINGLE ACTING SPRING FORCE

STROKE	Ø32 MM		Ø40 MM		Ø50 MM		Ø63 MM		Ø80 MM		Ø100 MM	
mm	Min.	Min.	Min.	Max.	Min.	Max.	Min.	Max.	Min.	Max.	Min.	Min.
10	50	54	72	82	110	123	110	123	166	180	166	180
20	44	54	62	82	98	123	98	123	152	180	152	180
30	40	54	52	82	86	123	86	123	137	180	137	180
40	35	54	42	82	73	123	73	123	123	180	123	180
50	30	54	32	82	60	123	60	123	110	180	110	180

Value in Newton (N), both spring return and spring extent.

D.A., adjustable cushioning
 S.A., spring return
 S.A., spring extend

SKZP-DMA

SKZP-SEM

SKZP-SM

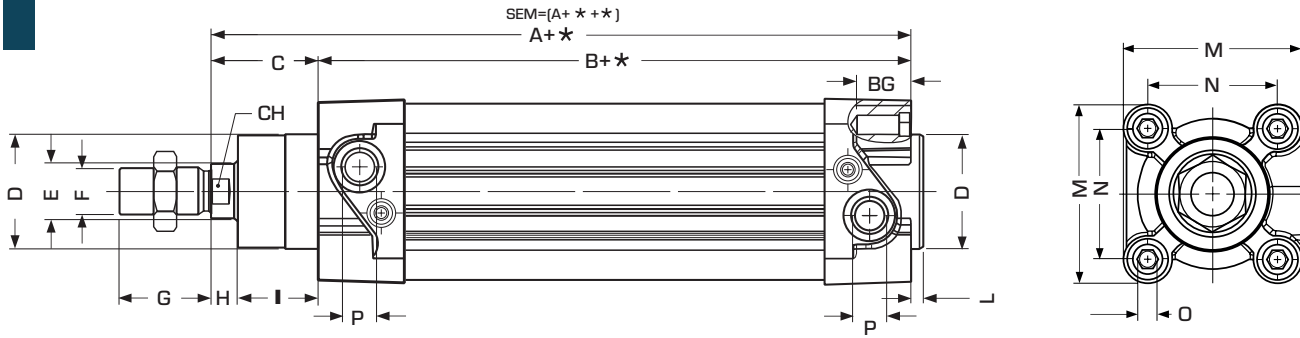
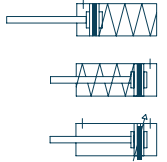

Ø	A	B	C	ØD	ØE	F	G	H	I	L	M	N	ØO	ØP	BG	CH
32	120	94	26	30	12	M10X1,25	20	7	19	3	47	32,5	M6	G1/8	16	10
40	135	105	30	35	16	M12X1,25	24	9	21	3	53	38	M6	G1/4	16	13
50	143	106	37	40	20	M16X1,5	32	10	27	3,5	65	46,5	M8	G1/4	16	17
63	158	121	37	45	20	M16X1,5	32	10	27	4	75	56,5	M8	G3/8	16	17
80	174	128	46	45	25	M20X1,5	40	13	33	4	95	72	M10	G3/8	18	21
100	189	138	51	55	25	M20X1,5	40	15	36	4	115	89	M10	G1/2	18	21
125	225	160	65	60	32	M27X2	54	25	40	6	140	110	M12	G1/2	22	27

Ø125 IS NOT AVAILABLE AS SINGLE ACTING

D.A., adjustable cushioning, through rod

SKZP-DMAP

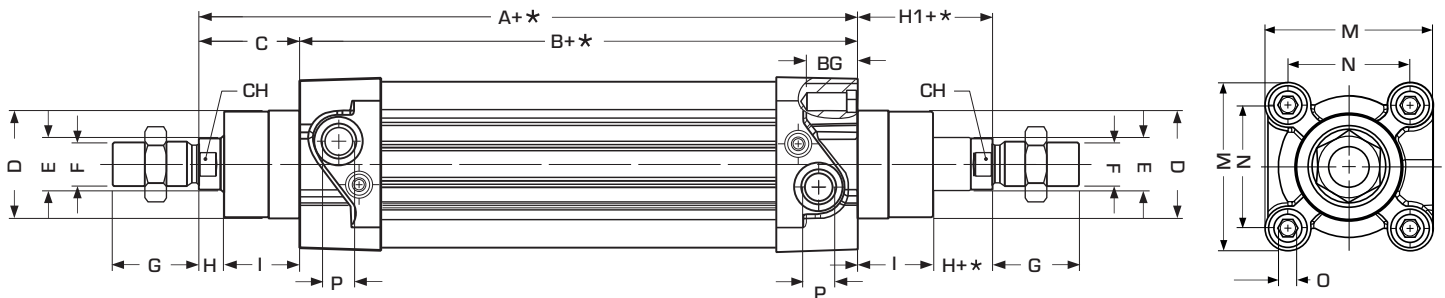
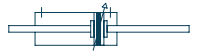

Ø	A	B	C	ØD	ØE	F	G	H	I	M	N	ØO	ØP	BG	CH
32	120	94	26	30	12	M10X1,25	20	7	19	47	32,5	M6	G1/8	16	10
40	135	105	30	35	16	M12X1,25	24	9	21	53	38	M6	G1/4	16	13
50	143	106	37	40	20	M16X1,5	32	10	27	65	46,5	M8	G1/4	16	17
63	158	121	37	45	20	M16X1,5	32	10	27	75	56,5	M8	G3/8	16	17
80	174	128	46	45	25	M20X1,5	40	13	33	95	72	M10	G3/8	18	21
100	189	138	51	55	25	M20X1,5	40	15	36	115	89	M10	G1/2	18	21
125	225	160	65	60	32	M27X2	54	25	40	140	110	M12	G1/2	22	27

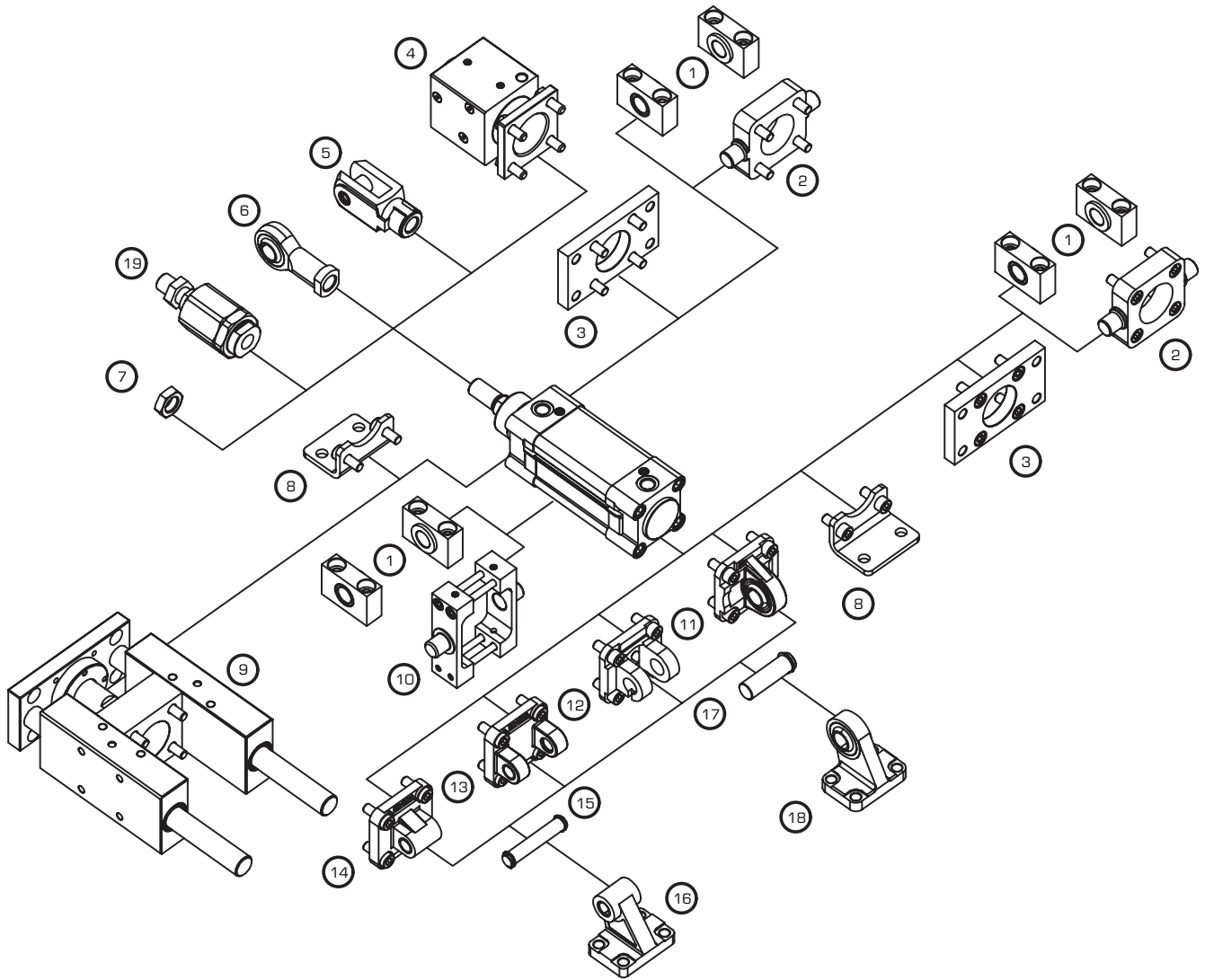

	DESCRIPTION	PROD. NR.
1	Support for intermediate hinge	SKAC20
2	Front-rear trunnion	SKAC21
3	Flange	SKAC17
4	Rod lock	Upon request
5	Clevis	SKAC03
6	Rod End	SKAC04
7	Piston rod nut	SKAC01
8	Low-rise pedestal	SKAC16
9	Guide unit	Upon request
10	Intermediate hinge for profile cylinder	SKAC18
11	Male hinge with spherical bearing	SKAC13
12	Clevis bracket, spherical eye, straight	SKAC11
13	Female hinge	SKAC08
14	Male hinge	SKAC10
15	Pivot for female hinge	SKAC09
16	Square joint	SKAC14
17	Pivot pin for spherical head	SKAC12
18	Square joint with sperical head	SKAC15
19	Self-aligning joint	SKAC02

ISO 15552 cylinders, big bore tie rods version.
 Featuring a clean design and suitable for heavy-duty applications.
 Available with or without magnet, with or without adjustable cushioning, single or through piston rod. Wide range of mounting accessories. Special versions available upon request.

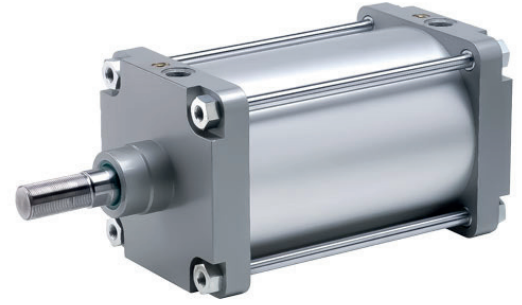

TECHNICAL FEATURES

END CAPS

Die-cast aluminium

TUBES

Anodized aluminium

SEALS

Polyurethane

TIE RODS

Stainless steel

CUSHIONING

Pneumatic adjustable cushions

PISTON ROD

Chromium plated steel

WORKING PRESSURE

10 bar

AMBIENT TEMPERATURE

-10 °C - + 80 °C

MEDIUM TEMPERATURE

0 °C - + 40 °C

MEDIUM

Filtered and (un)lubricated air

VERSION

DMA		DMAP	
-----	-------------------------------------------------------------------------------------	------	-------------------------------------------------------------------------------------

SKZP	VERSION	OPTIONAL	DIAMETER	STROKE	OPTIONS
DA	Double acting with adjustable cushioning	X for AISI 316	160 200 250 320	0...2700	- Standard
DMA	Double acting, magnetic, with adjustable cushioning				Y FKM rod seal
DAP	Double acting, with adjustable cushioning and through rod				V All seals
DMAP	Double acting through rod with adjustable cushioning magnetic				I Stainless steel rod AISI 304
					X Stainless steel rod AISI 316L

STANDARD STROKE LENGTHS

Big bore tie rod ISO 15552 cylinders are standard available with stroke lengths from 25 to 1000.

EFFECTIVE CUSHION LENGTH

BORE	LENGTH
160	45
200	45
250	45
320	45

THEORETICAL FORCES AT 6 BAR

Ø (MM)	THRUST FORCE (N)	TRACTION FORCE (N)
160	12058	11304
200	18840	18086
250	29438	28261
320	48230	46361

SWITCH MOUNTING

There are also magnetic switch mounting accessories available for tie-rod cylinders and big bore tie-rod cylinders. Use code "SKAC-MB" followed by the required diameter of the cylinder. For example: SKAC-MB160 for a cylinder with bore \varnothing 160.

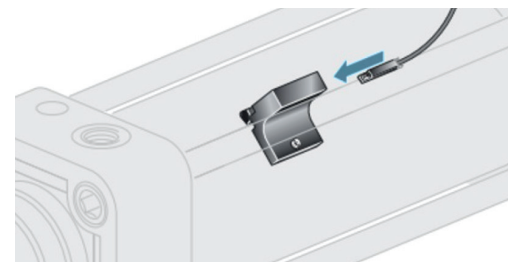

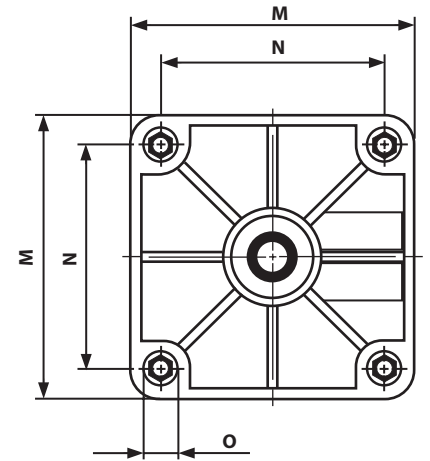
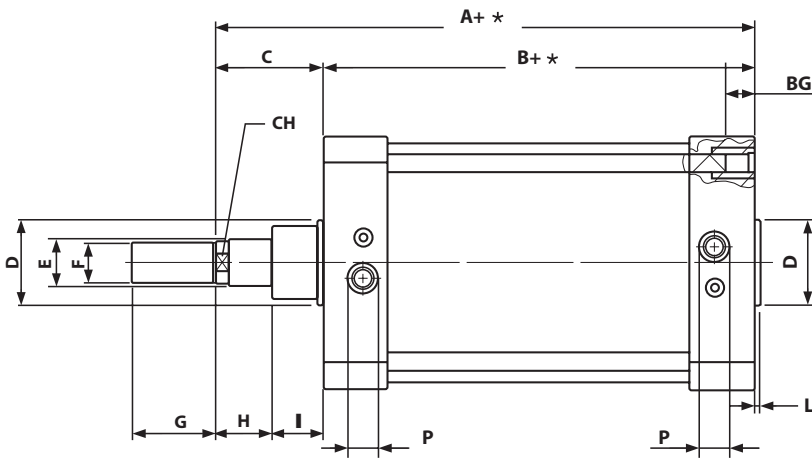
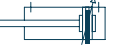

Ø	A	B	C	ØD	ØE	F	G	H	I	L	M	N	ØO	ØP	BG	CH
160	260	180	80	65	40	M36x2	72	25	55	6	180	140	M16	G3/4	22	36
200	275	180	95	75	40	M36x2	72	28	67	5	220	175	M16	G3/4	22	36
250	305	200	105	105	50	M42x2	84	30	75	8	270	220	M20	G1	25	46
320	340	220	120	120	63	M48x2	96	30	90	10	350	270	M24	G1	28	55

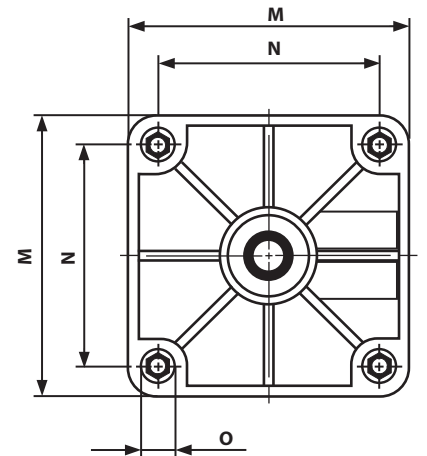
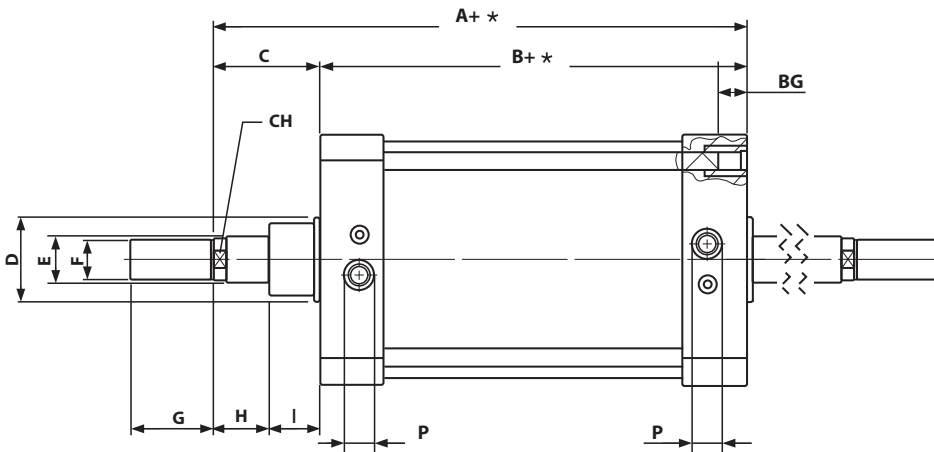
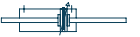

Ø	A	B	C	ØD	ØE	F	G	H	I	L	M	N	ØO	ØP	BG	CH
160	260	180	80	65	40	M36x2	72	25	55	6	180	140	M16	G3/4	22	36
200	275	180	95	75	40	M36x2	72	28	67	5	220	175	M16	G3/4	22	36
250	305	200	105	105	50	M42x2	84	30	75	8	270	220	M20	G1	25	46
320	340	220	120	120	63	M48x2	96	30	90	10	350	270	M24	G1	28	55

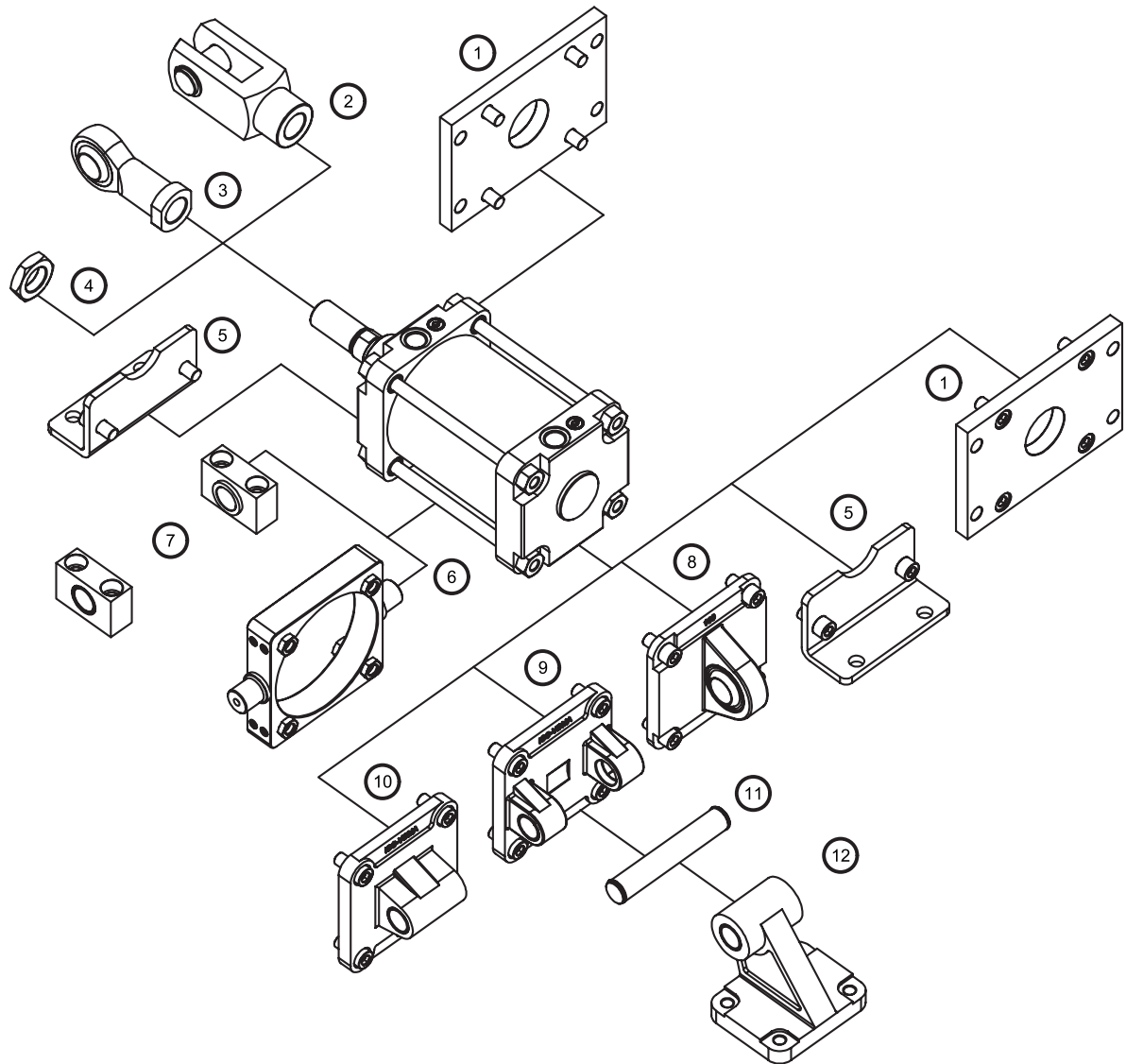

	DESCRIPTION	PROD. NR.
1	Flange	SKAC17
2	Clevis	SKAC03
3	Rod end	SKAC04
4	Rod end nut	SKAC01
5	Low-rise pedestal	SKAC16
6	Intermediate hinge for tie-rod cylinder	SKAC19
7	Support for intermediate hinge	SKAC20
8	Male hinge with spherical bearing	SKAC13
9	Clevis bracket	SKAC11
10	Male hinge	SKAC10
11	Pivot pin	SKAC09
12	Square joint	SKAC14

ISO 21287 compact cylinders. Available with magnet, single or double acting, with male or female thread on rod end. Also available with through rod or as non-rotating version. Wide range of accessories available.

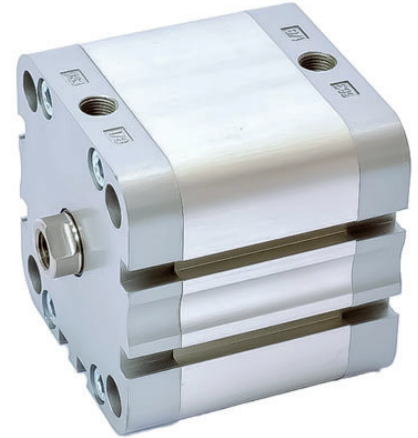

TECHNICAL FEATURES

COVERS

Die-cast aluminium

TUBE

Anodized aluminium

PISTON ROD

ø16 and 25 AISI 304
ø32 - 100 AISI 420 A

ROD & PISTON SEALS

Polyurethane

BEARING

Sintered bronze

MAX WORKING PRESSURE

1-10 BAR

AMBIENT TEMPERATURE RANGE

0°C - + 80°C

MEDIUM TEMPERATURE RANGE

0°C - + 30°C

MEDIUM

Filtered and (un)lubricated air

VERSION

SM		SEM	
DM		DMP	

VERSION

SKC-	VERSION	BODY	DIAMETER	THREAD	STROKE	OPTIONS
SM	Single acting, magnetic	I for AISI 316	16	M Male	5 - 250	- Standard
SEM	Single acting, spring extend, magnetic		20	F Female		Y YFKM rod seal
DM	Double acting, magnetic		25			V FKM seals
DMP	Double acting, magnetic, through rod		32			NR Non-Rotating
			40			
			50			
			63			
			80			
			100			

S.A., spring return, female thread
D.A., female thread

SKC-SM

SKC-DM

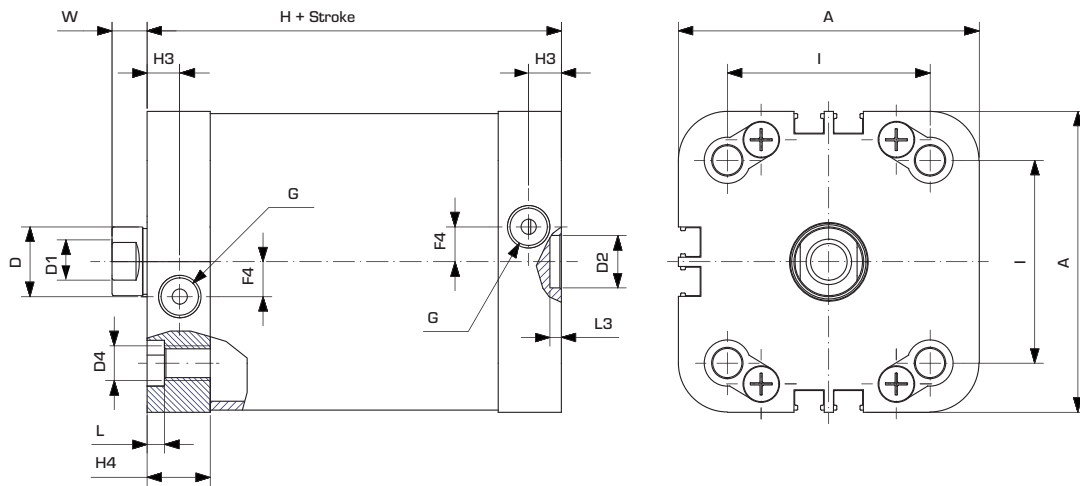
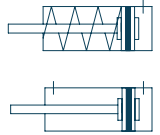

Ø	A	D	D1	D2	D4	G	I	L	H	W	H3	H4	L3	F4
16	29,2	8	M4	6	M4	M5	18	3,5	37	4,5	7	12,8	2,2	0
20	37	10	M6	6	M5	M5	22	4,2	37	6	7	12,3	2,5	4
25	41	10	M6	6	M5	M5	26	4,2	39	6	7,5	13,5	2,5	3
32	49,2	12	M8	6	M6	G1/8	32,5	4,5	44	7	7,5	15	2	0
40	57,2	12	M8	6	M6	G1/8	38	4,2	45	7	7,5	15	2	0
50	67	16	M10	8	M8	G1/8	46,5	4,7	45	8	7,5	14,6	2,5	0
63	80	16	M10	8	M8	G1/8	56,5	5,2	49	8	8	15,5	2,5	0
80	102,6	20	M12	8	M10	G1/8	72	5,2	54	10	9	17	2,5	0
100	124	25	M12	8	M10	G1/4	89	5,2	67	10	10	20	3	0

S.A., spring extend, female thread

SKC-SEM

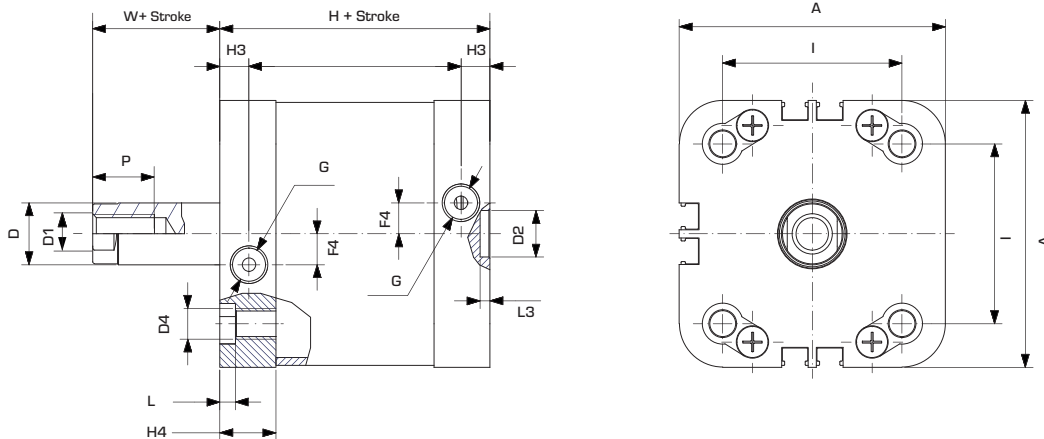

Ø	A	D	D1	D2	D4	G	I	L	H	W	H3	H4	L3	F4
16	29,2	8	M4	6	M4	M5	18	3,5	47	4,5	7	12,8	2,2	0
20	37	10	M6	6	M5	M5	22	4,2	47	6	7	12,3	2,5	4
25	41	10	M6	6	M5	M5	26	4,2	59	6	7,5	13,5	2,5	3
32	49,2	12	M8	6	M6	G1/8	32,5	4,5	64	7	7,5	15	2	0
40	57,2	12	M8	6	M6	G1/8	38	4,2	65	7	7,5	15	2	0
50	67	16	M10	8	M8	G1/8	46,5	4,7	65	8	7,5	14,6	2,5	0
63	80	16	M10	8	M8	G1/8	56,5	5,2	69	8	8	15,5	2,5	0
80	102,6	20	M12	8	M10	G1/8	72	5,2	84	10	9	17	2,5	0
100	124	25	M12	8	M10	G1/4	89	5,2	97	10	10	20	3	0

S.A., spring return, male thread
D.A., male thread

SKC-SM

SKC-DM

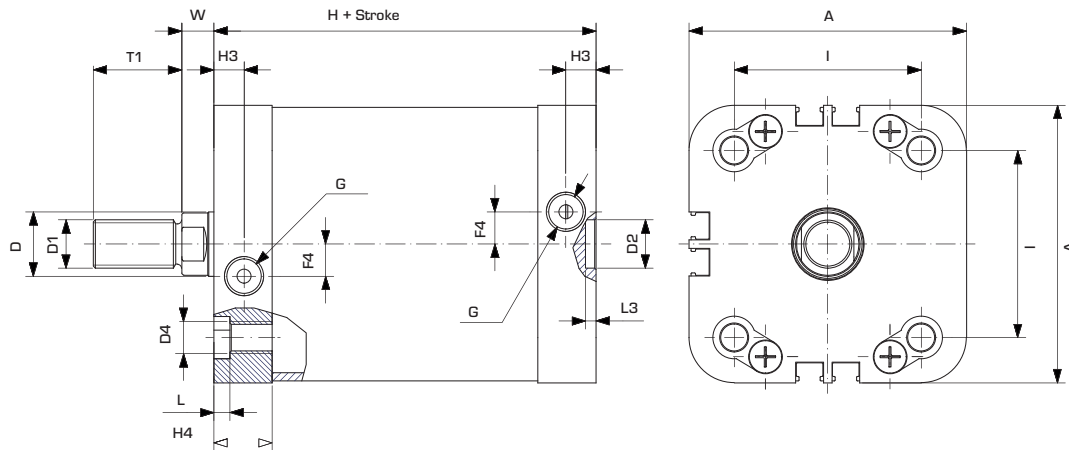
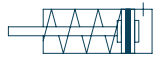

Ø	A	D	D1	D2	D4	G	I	L	H	W	H3	H4	L3	F4	T1
16	29,2	8	M6x1	6	M4	M5	18	3,5	37	4,5	7	12,8	2,2	0	12
20	37	10	M8x1,25	6	M5	M5	22	4,2	37	6	7	12,3	2,5	4	16
25	41	10	M8x1,25	6	M5	M5	26	4,2	39	6	7,5	13,5	2,5	3	16
32	49,2	12	M10x1,25	6	M6	G1/8	32,5	4,5	44	7	7,5	15	2	0	19
40	57,2	12	M10x1,25	6	M6	G1/8	38	4,2	45	7	7,5	15	2	0	19
50	67	16	M12x1,25	8	M8	G1/8	46,5	4,7	45	8	7,5	14,6	2,5	0	22
63	80	16	M12x1,25	8	M8	G1/8	56,5	5,2	49	8	8	15,5	2,5	0	22
80	102,6	20	M16x1,5	8	M10	G1/8	72	5,2	54	10	9	17	2,5	0	28
100	124	25	M16x1,5	8	M10	G1/4	89	5,2	67	10	10	20	3	0	28

S.A., spring extend, male thread

SKC-SEM

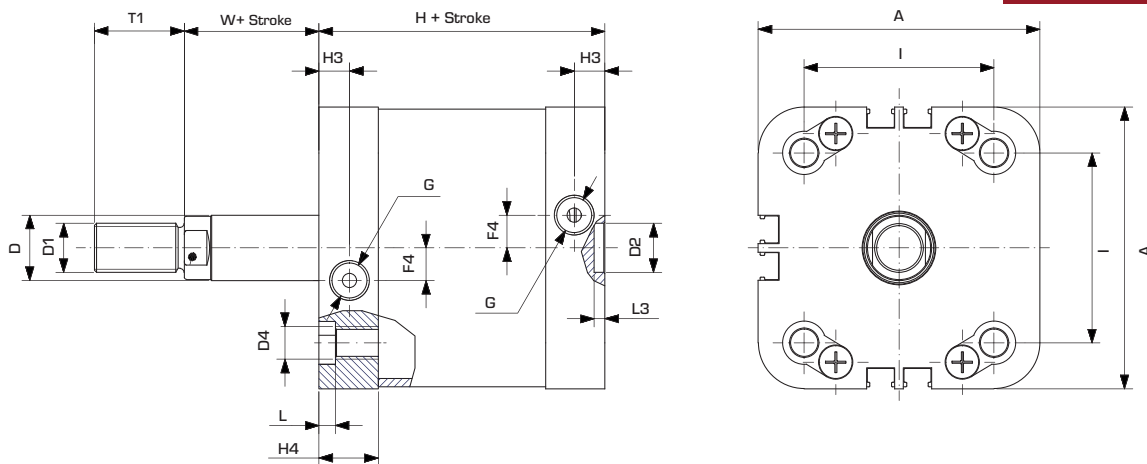

Ø	A	D	D1	D2	D4	G	I	L	H	W	H3	H4	L3	F4	T1
16	29,2	8	M6x1	6	M4	M5	18	3,5	47	4,5	7	12,8	2,2	0	12
20	37	10	M8x1,25	6	M5	M5	22	4,2	47	6	7	12,3	2,5	4	16
25	41	10	M8x1,25	6	M5	M5	26	4,2	59	6	7,5	13,5	2,5	3	16
32	49,2	12	M10x1,25	6	M6	G1/8	32,5	4,5	64	7	7,5	15	2	0	19
40	57,2	12	M10x1,25	6	M6	G1/8	38	4,2	65	7	7,5	15	2	0	19
50	67	16	M12x1,25	8	M8	G1/8	46,5	4,7	65	8	7,5	14,6	2,5	0	22
63	80	16	M12x1,25	8	M8	G1/8	56,5	5,2	69	8	8	15,5	2,5	0	22
80	102,6	20	M16x1,5	8	M10	G1/8	72	5,2	84	10	9	17	2,5	0	28
100	124	25	M16x1,5	8	M10	G1/4	89	5,2	97	10	10	20	3	0	28

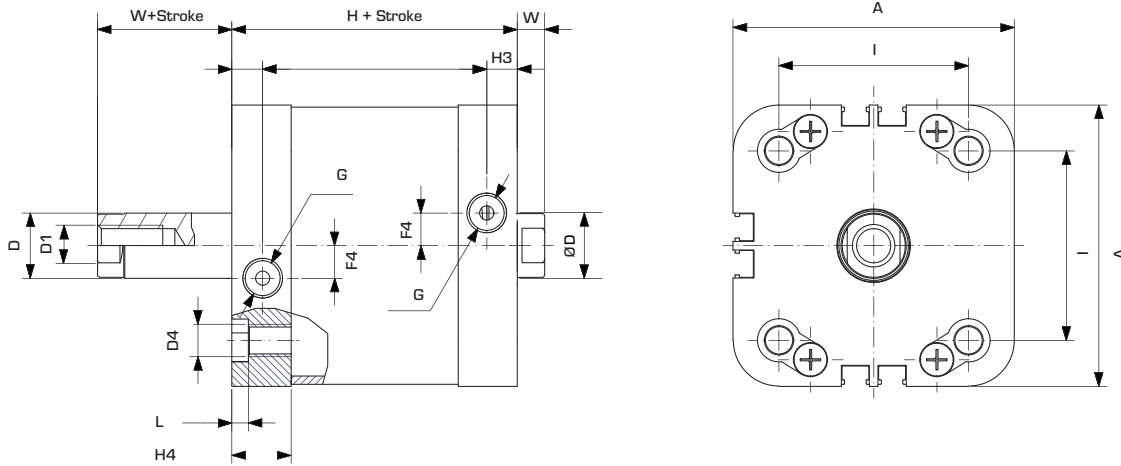

Ø	A	D	D1	D2	D4	G	I	L	H	W	H3	H4	L3	F4
16	29,2	8	M4	6	M4	M5	18	3,5	37	4,5	7	12,8	2,2	0
20	37	10	M6	6	M5	M5	22	4,2	37	6	7	12,3	2,5	4
25	41	10	M6	6	M5	M5	26	4,2	39	6	7,5	13,5	2,5	3
32	49,2	12	M8	6	M6	G1/8	32,5	4,5	44	7	7,5	15	2	0
40	57,2	12	M8	6	M6	G1/8	38	4,2	45	7	7,5	15	2	0
50	67	16	M10	8	M8	G1/8	46,5	4,7	45	8	7,5	14,6	2,5	0
63	80	16	M10	8	M8	G1/8	56,5	5,2	49	8	8	15,5	2,5	0
80	102,6	20	M12	8	M10	G1/8	72	5,2	54	10	9	17	2,5	0
100	124	25	M12	8	M10	G1/4	89	5,2	67	10	10	20	3	0

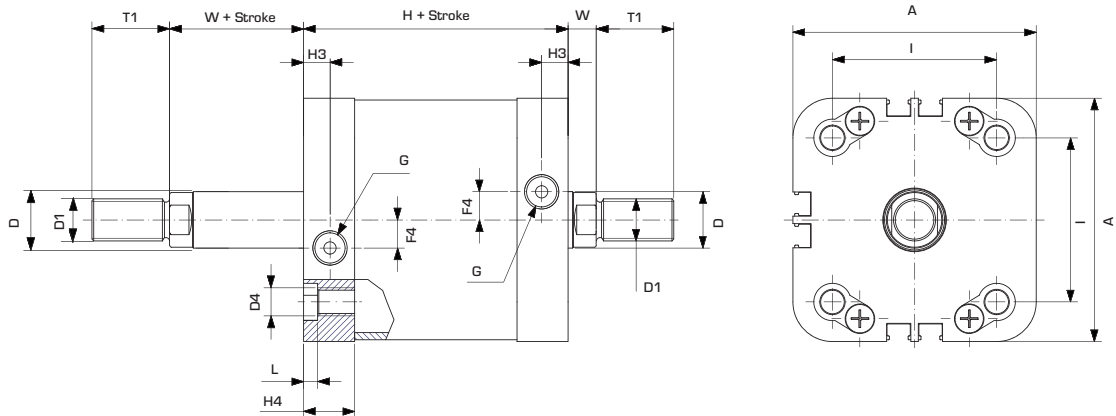

Ø	A	D	D1	D2	D4	G	I	L	H	W	H3	H4	L3	F4	T1
16	29,2	8	M4	6	M4	M5	18	3,5	37	4,5	7	12,8	2,2	0	12
20	37	10	M6	6	M5	M5	22	4,2	37	6	7	12,3	2,5	4	16
25	41	10	M6	6	M5	M5	26	4,2	39	6	7,5	13,5	2,5	3	16
32	49,2	12	M8	6	M6	G1/8	32,5	4,5	44	7	7,5	15	2	0	19
40	57,2	12	M8	6	M6	G1/8	38	4,2	45	7	7,5	15	2	0	19
50	67	16	M10	8	M8	G1/8	46,5	4,7	45	8	7,5	14,6	2,5	0	22
63	80	16	M10	8	M8	G1/8	56,5	5,2	49	8	8	15,5	2,5	0	22
80	102,6	20	M12	8	M10	G1/8	72	5,2	54	10	9	17	2,5	0	28
100	124	25	M12	8	M10	G1/4	89	5,2	67	10	10	20	3	0	28

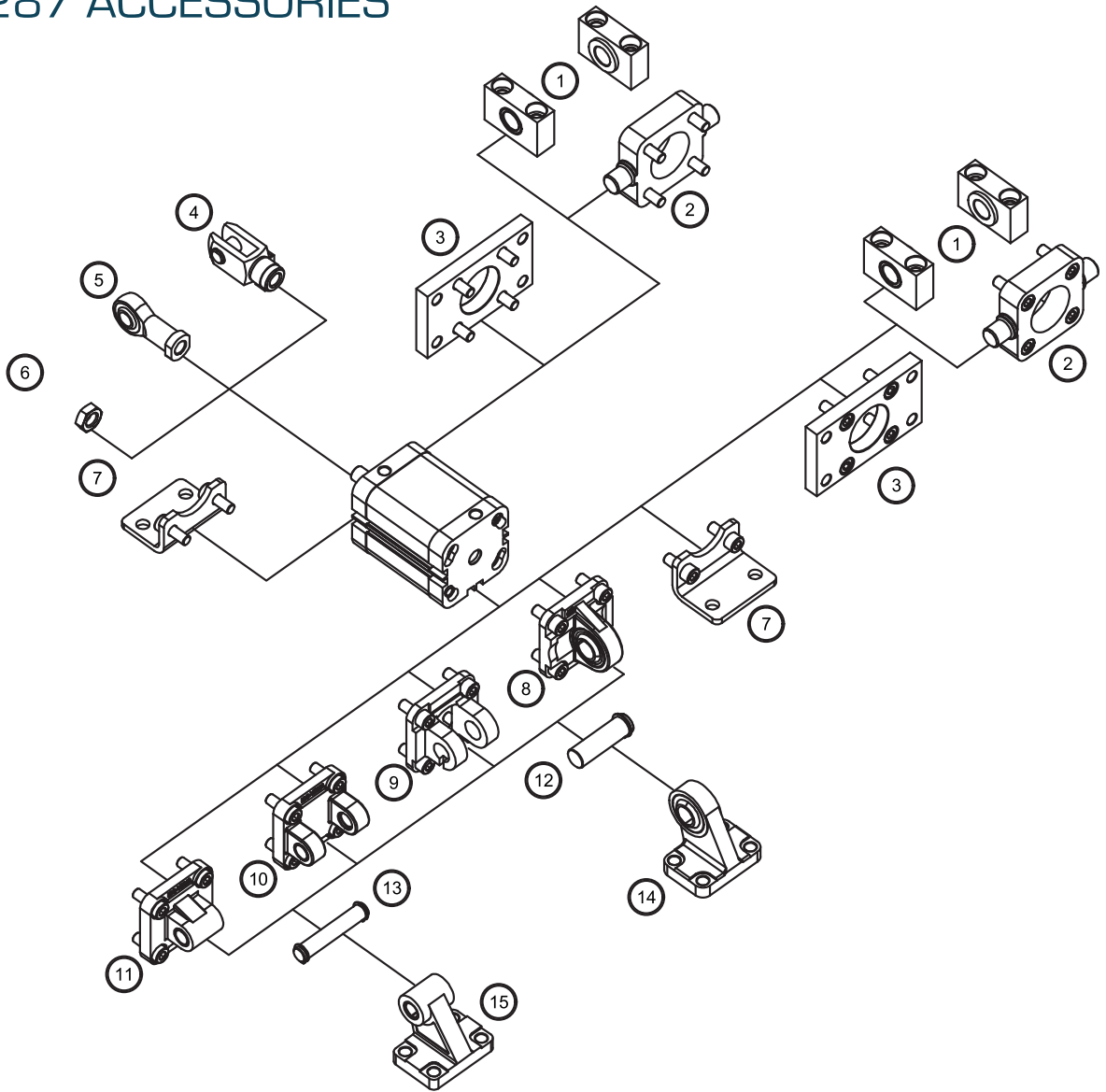

	DESCRIPTION	PROD. NR.
1	Support for intermediate hinge	SKAC20
2	Front-rear trunnion	SKAC21
3	Flange	SKAC17
4	Clevis	SKAC03
5	Rod end	SKAC04
6	Piston rod nut	SKAC01
7	Low-rise pedestal	SKAC16
8	Male hinge with spherical bearing	SKAC13
9	Clevis bracket, spherical eye	SKAC11
10	Female hinge	SKAC08
11	Male hinge	SKAC10
12	Pivot pin, spherical bearing	SKAC12
13	Pivot for female hinge	SKAC09
14	Square joint with spherical head	SKAC15
15	Square joint	SKAC14
16	Self-aligning joint	SKAC02

In addition to our range of standard pneumatic cylinders, we also excel in helping our customers with their specific needs. There are practical applications where a standard solution is insufficient. Thanks to our years of experience in pneumatics, SKUPP can manufacture specials like no other. Whether it's a replacement cylinder for an existing system or a completely custom design, we help you select, modify, or develop a cylinder that perfectly matches the application.

Designs and constructions

Special cylinders come in many different forms. Consider, for example, classic CNOMO cylinders for replacing older systems. Or cylinders with a hollow piston rod so you can apply grippers on the rod end. Also, we are able to provide telescopic cylinders for applications requiring a large stroke within limited space. And of course: cylinders with unusual specifications, such as a non-standard stroke length or with an extended piston rod.

Special conditions and applications

In addition to unusual designs, we also provide solutions for special applications and challenging operating conditions. For example, cylinders can be supplied suitable for usage with (low-pressure) oil, which offers an alternative to traditional hydraulics in certain industrial applications. Cylinders are also available with protective bellows to protect the piston rod from dirt, dust, or moisture. For applications requiring exceptionally smooth movement, low-friction designs are available. By combining these options, a cylinder is created that performs optimally within the specific requirements of the application.







ACCESSORIES

ACCESSORIES

SKAC01 ROD NUT



STEEL

STAINLESS STEEL

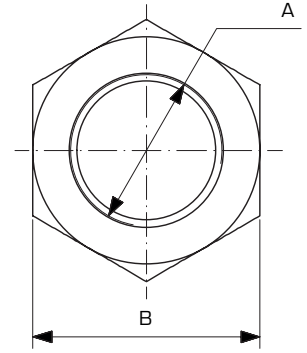
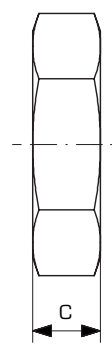

CODE	A	B	C
------	---	---	---

SKAC01-0810*	M4	7	3.2
SKAC01-1216*	M6	10	4
SKAC01-20*	M8X1.25	13	5
SKAC01-25*	M10X1.25	17	6
SKAC01-32*	M10X1.5	17	6
SKAC01-40*	M12X1.75	19	7
SKAC01-50*	M16X1.5	22	5
SKAC01-5063*	M16X2	24	8
SKAC01-80100*	M20X1.5	30	9
SKAC01-125*	M27X2	41	12
SKAC01-160200*	M36X2	55	14
SKAC01-250*	M42X2	65	16
SKAC01-320*	M48X2	75	18

*While ordering, add Z for zinc coated steel or I for AISI 304.
For example: SKAC01-20Z for zinc coated steel.

SKAC02 SELF-ALIGNING JOINTS



STEEL

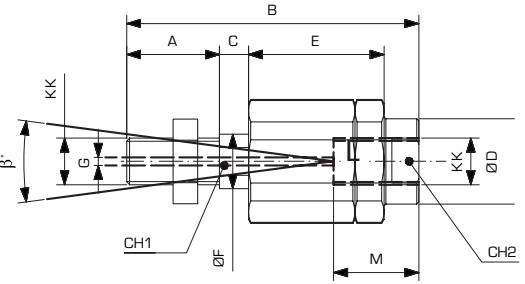
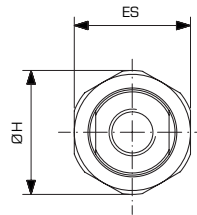

CODE	KK	B	A	C	E	ØF	ØD	ØH	ES	G	M	CH1	CH2	SS°
------	----	---	---	---	---	----	----	----	----	---	---	-----	-----	-----

SKAC02-6X1Z	M6X1	35	10	2.5	17.5	6	8.5	14.5	13	1	12.5	5	7	6
SKAC02-8X125Z	M8X1.25	57	20	5	26	8	12.5	19	17	2	16	7	11	8
SKAC02-10X125Z	M10X1.25	71.5	20	7.5	35	14	22	32	30	2	22	12	19	8
SKAC02-10X150Z	M10X1.50	71.5	20	7.5	35	14	22	32	30	2	22	12	19	8
SKAC02-12X125Z	M12X1.25	75.5	24	7.5	35	14	22	32	30	2	22	12	19	8
SKAC02-12X175Z	M12X1.75	75.5	24	7.5	35	14	22	32	30	2	22	12	20	9
SKAC02-16X150Z	M16X1.50	104	32	10	53	22	32	45	41	2	30	20	27	6
SKAC02-20X150Z	M20X1.50	119	40	10	53	22	32	45	41	2	37	20	27	6
SKAC02-27X2Z	M27X2	147	54	10	60	32	57	70	65	2	48	24	54	8
SKAC02-36X2Z	M36X2	190	72	15.5	77	39	57	75	70	2	68	32	54	8

SKAC03

FEMALE FORK WITH LOCKABLE PIN

STEEL

STAINLESS STEEL

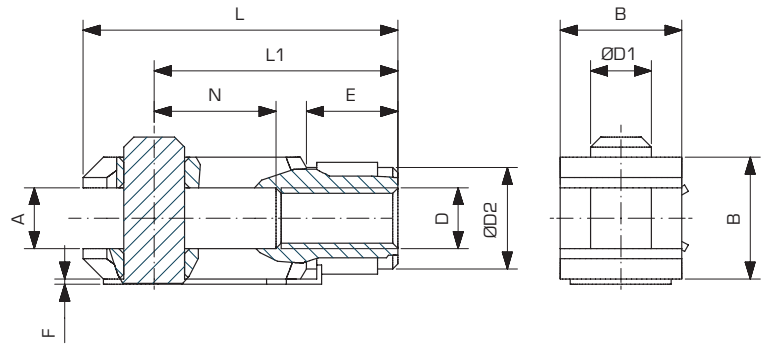
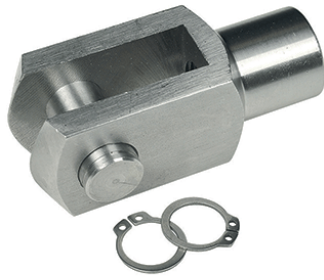

CODE	D	A	F	L1	N	E	B	D1	D2	L
SKAC03-4ISO*	M4	4	0.5	16	8	6	8	4	8	21
SKAC03-6ISO*	M6	6	0.5	24	12	9	12	6	10	31
SKAC03-8ISO*	M8	8	0.5	32	16	12	16	8	14	42
SKAC03-10ISO*	M10X1.25	10	0.5	40	20	15	20	10	18	52
SKAC03-10DIN*	M10X1.5	10	0.5	40	20	15	20	10	18	52
SKAC03-12ISO*	M12X1.25	12	0.5	48	24	18	24	12	20	62
SKAC03-12DIN*	M12X1.75	12	0.5	48	24	18	24	12	20	62
SKAC03-16ISO*	M16X1.5	16	1	64	32	24	32	16	26	83
SKAC03-16DIN*	M16X2	16	1	64	32	24	32	16	26	83
SKAC03-20ISO*	M20X1.5	20	1	80	40	30	40	20	34	105

While ordering, add Z for zinc coated steel or I for AISI 303.
For example: SKAC01-20Z for zinc coated steel.

SKAC03

FEMALE FORK WITH PIVOT, LARGER SIZES

STEEL

STAINLESS STEEL

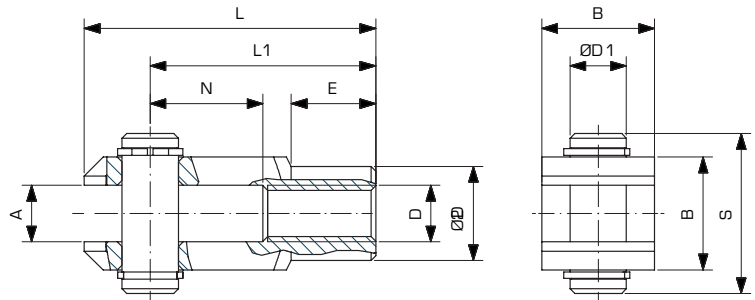

CODE	D3	W	L3	A	ØD	ØD1	C1	B	ØD4	ØD5
SKAC03-27ISO*	M27X2	30	55	30	65	54	110	148	38	48
SKAC03-36DIN*	M36X2	35	70	35	84	72	144	188	40	60
SKAC03-42DIN*	M42X2	40	85	40	104.3	84	168	232	63.5	70
SKAC03-48DIN*	M48X2	50	96	50	117.3	96	192	265	73	82

*While ordering, add Z for zinc coated steel or I for AISI 304.

SKAC04

ROD END

STEEL

STAINLESS STEEL

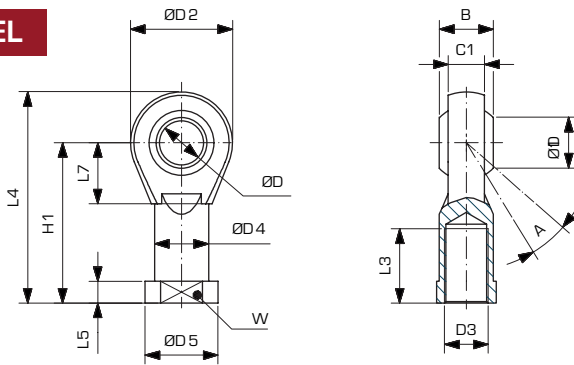

CODE	D3	W	L3	A	ØD	ØD1	C1	B	ØD4	ØD5	L5	L7	H1	L4	D2
------	----	---	----	---	----	-----	----	---	-----	-----	----	----	----	----	----

SKAC04-4X07*	M4	9	10	13°	5	7.7	6	8	9	11	4	10	27	36	18
SKAC04-6X1*	M6	11	12	13°	6	8.9	6.75	9	10	13	5	11	30	40	20
SKAC04-8X125*	M8	14	16	14°	8	10.4	9	12	12.5	16	5	13	36	48	24
SKAC04-10X125*	M10X1.25	17	20	13°	10	12.9	10.5	14	15	19	6.5	15	43	57	28
SKAC04-10X15*	M10X1.5	17	20	13°	10	12.9	10.5	14	15	19	6.5	15	43	57	28
SKAC04-12X125*	M12X1.25	19	22	13°	12	15.4	12	16	17.5	22	6.5	17	50	66	32
SKAC04-12X175*	M12X1.75	19	22	13°	12	15.4	12	16	17.5	22	6.5	17	50	66	32
SKAC04-16X15*	M16X1.5	22	28	15°	16	19.3	15	21	22	27	8	23	64	85	42
SKAC04-16X2*	M16X2	22	28	15°	16	19.3	15	21	22	27	8	23	64	85	42
SKAC04-20X15*	M20X1.5	30	33	14°	20	24.3	18	25	27.5	34	10	27	77	102	50
SKAC04-27X2*	M27X2	41	51	17°	30	34.8	25	37	40	50	15	36	110	145	70
SKAC04-36X2*	M36X2	50	56	19°	35	37.7	28	43	46	58	17	41	125	165	80
SKAC04-42X2*	M42X2	55	60	16°	40	45.1	33	49	53	65	19	45	142	187	91
SKAC04-48X2*	M48X2	65	65	14°	50	56.6	45	60	65	75	23	58	162	218	117

*While ordering, add Z for zinc coated steel or I for stainless steel.
For example: SKAC01-20Z for zinc coated steel.

SKAC05

FOOT ISO 6432

STEEL

STAINLESS STEEL

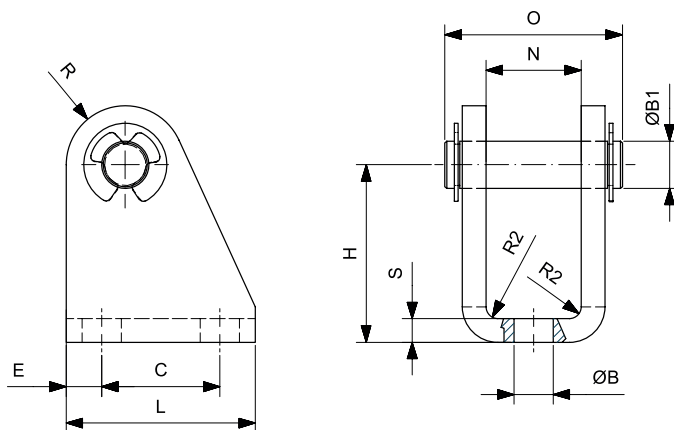

CODE	ØMM	L	H	B1	S	E	C	N	B	O	R	R2
------	-----	---	---	----	---	---	---	---	---	---	---	----

SKAC05-0810*	8-10	22	24	4	2.5	4.75	12.5	8.1	4.5	18	5	1.5
SKAC05-1216*	12-16	25	27	6	3	5	15	12.1	5.5	24	7	1.5
SKAC05-2025*	20-25	32	30	8	4	6	20	16.1	6.6	31	10	2

While ordering, add Z for zinc coated steel or I for stainless steel.
For example: SKAC01-20Z for zinc coated steel.

SKAC06

FOOT ISO 6432

STEEL

STAINLESS STEEL

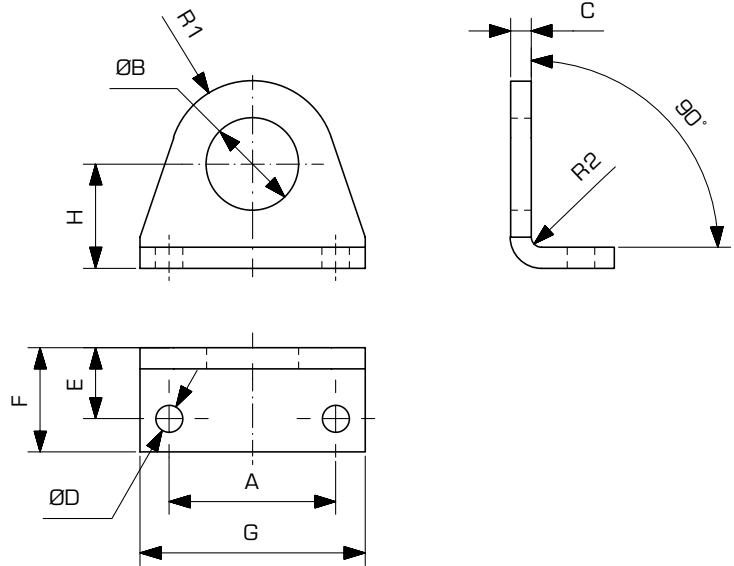

CODE	ØMM	A	ØB	C	ØD	E	F	G	H	R1	R2	R2
SKAC06-0810*	8-10	25	12	3	4.5	11	16	35	16	10	1.5	1.5
SKAC06-1216*	12-16	32	16.1	4	5.5	14	20	42	20	13	2	1.5
SKAC06-2025*	20-25	40	22.1	5	6.6	17	25	54	25	20	2.5	2

*While ordering, add Z for zinc coated steel or I for stainless steel.
For example: SKAC01-20Z for zinc coated steel.

SKAC07

FLANGE ISO 6432

STEEL

STAINLESS STEEL

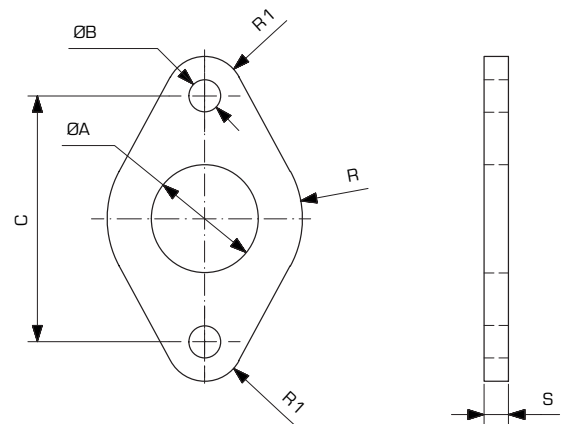
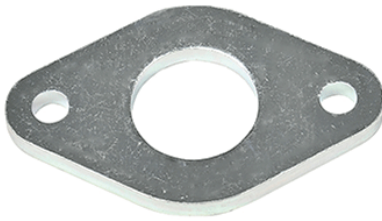

CODE	ØMM	ØA	ØB	C	R	R1	S
SKAC07-0810*	8-10	12	4.5	30	11	5	3
SKAC07-1216*	12-16	16	5.5	40	15	6	4
SKAC07-2025*	20-25	22	6.5	50	20	8	5

*While ordering, add Z for zinc coated steel or I for stainless steel.
For example: SKAC01-20Z for zinc coated steel.

SKAC08

FEMALE HINGE

STEEL

STAINLESS STEEL

ALUMINIUM

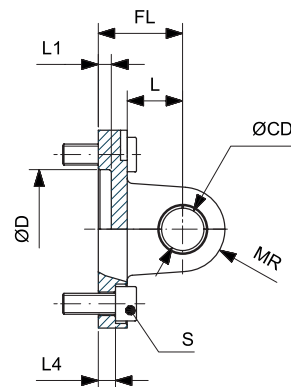
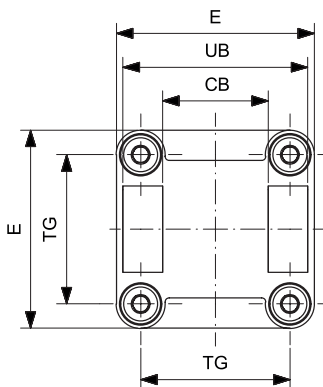
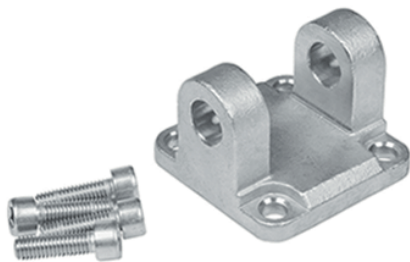

CODE	Ø	TG	CB	UB	ØCD	FL	L	ØD	L1	L4	S	MR	E
SKAC08-32*	32	32.5	26	45	10	22	13	30	5	5.5	M6X20	10	45
SKAC08-40*	40	38	28	52	12	25	16	35	5	5.5	M6X20	12	52
SKAC08-50*	50	46.5	32	60	12	27	16	40	5	6.5	M8X20	12	65
SKAC08-63*	63	56.5	40	70	16	32	21	45	5	6.5	M8X20	16	75
SKAC08-80*	80	72	50	90	16	36	22	45	5	10	M10X25	16	95
SKAC08-100*	100	89	60	110	20	41	27	55	5	10	M10X25	20	115
SKAC08-125*	125	110	70	130	25	50	30	60	7	10	M12X25	25	140
SKAC08-160*	160	140	90	170	30	55	35	65	7	10	M16X30	25	180
SKAC08-200*	200	175	90	170	30	60	35	75	7	11	M16X30	25	220

*While ordering, add Z for zinc coated steel, ZB for black painted steel, A for aluminium or X for AISI 316. Add 1 for screws or 2 for screws and pin. For example: SKAC01-20Z2 for zinc coated steel, with screws and pin.

SKAC09

PIN FOR FEMALE HINGE

STEEL

STAINLESS STEEL

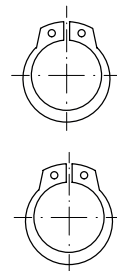
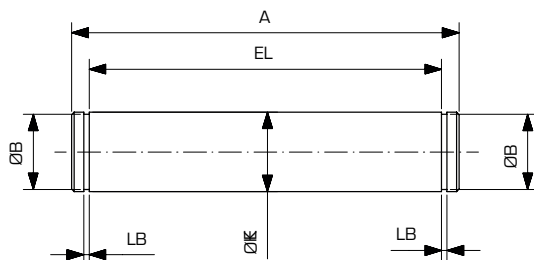

CODE	ØMM	ØEK	EL	ØB	LB	A
SKAC09-32*	32	10	46	9.6	1.1	53
SKAC09-40*	40	12	53	11.5	1.1	60
SKAC09-50*	50	12	61	11.5	1.1	68
SKAC09-63*	63	16	71	15.2	1.1	78
SKAC09-80*	80	16	91	15.2	1.1	98
SKAC09-100*	100	20	111	19	1.3	118
SKAC09-125*	125	25	132	23.9	1.3	139
SKAC09-160*	160-200	30	172	28.6	1.6	180
SKAC09-250*	250	40	202	37.5	1.85	214
SKAC09-320*	320	45	222	42.5	1.85	234

*While ordering, add Z for zinc coated steel or X for stainless steel. For example: SKAC01-20Z for zinc coated steel.

SKAC10

MALE HINGE

STEEL

STAINLESS STEEL

ALUMINIUM

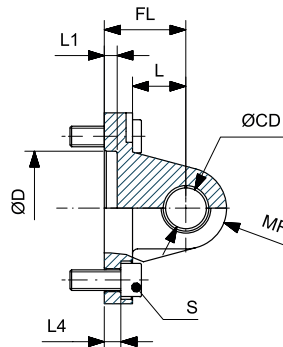
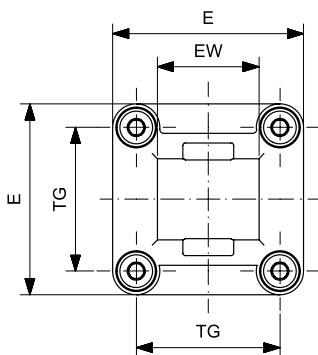
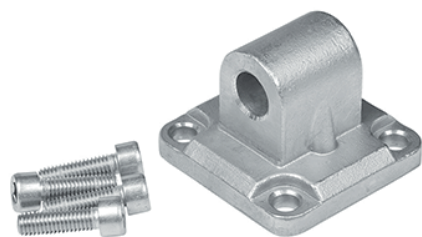

CODE	ØMM	TG	EW	ØCD	FL	L	ØD	L1	L4	S	MR	E
SKAC10-20*	20	22	16	8	20	12	12	4,5	3	M5X16	8	36
SKAC10-25*	25	26	16	8	20	12	12	4,5	3	M5X16	8	39,5
SKAC10-32*	32	32,5	26	10	22	13	30	5	5,5	M6X20	10	45
SKAC10-40*	40	38	28	12	25	16	35	5	5,5	M6X20	12	52
SKAC10-50*	50	46,5	32	12	27	16	40	5	6,5	M8X20	12	65
SKAC10-63*	63	56,5	40	16	32	21	45	5	6,5	M8X20	16	75
SKAC10-80*	80	72	50	16	36	22	45	5	10	M10X25	16	95
SKAC10-100*	100	89	60	20	41	27	55	5	10	M10X25	20	115
SKAC10-125*	125	110	70	25	50	30	60	7	10	M12X25	25	140
SKAC10-160*	160	140	90	30	55	35	65	7	10	M16X30	25	180
SKAC10-200*	200	175	90	30	60	35	75	7	11	M16X30	25	220
SKAC10-250*	250	220	110	40	70	45	90	11	11	M20X35	40	270

*While ordering, add Z for zinc coated steel, ZB for black painted steel, A for aluminium or I for AISI 304.

Add 1 for screws. For example: SKAC01-20Z1 for zinc coated steel, with screws.

Ø20-25 according to ISO 21287

SKAC11

FEMALE HINGE, SPHERICAL

STEEL

STAINLESS STEEL

ALUMINIUM

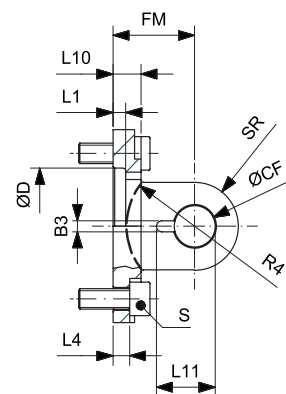
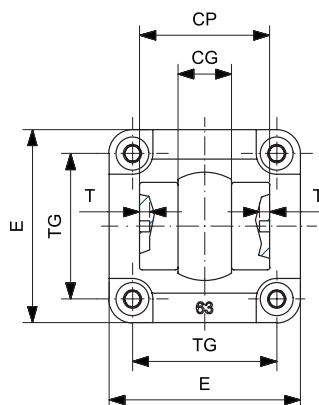

CODE	Ø	E	CP	CG	TG	FM	L1	L10	L4	ØD	ØCF	T	B3	L11	SR	R4	S
SKAC11-32*	32	45	34	14	32,5	22	5	9	5,5	30	10	3	3,3	16,5	9,5	17	M6X20
SKAC11-40*	40	52	40	16	38	25	5	9	5,5	35	12	4	4,3	18	12	20	M6X20
SKAC11-50*	50	65	45	21	46,5	27	5	11	6,5	40	16	4	4,3	23	14	22	M8X20
SKAC11-63*	63	75	51	21	56,5	32	5	11	6,5	45	16	4	4,3	23	17	25	M8X20
SKAC11-80*	80	95	65	25	72	36	5	14	10	45	20	4	4,3	27	21	30	M10X25
SKAC11-100*	100	115	75	25	89	41	5	14	10	55	20	4	4,3	27	21	32	M10X25
SKAC11-125*	125	140	97	37	110	50	7	20	10	60	30	6	6,3	40	29	42	M12X25

*While ordering, add Z for zinc coated steel, A for aluminium or X for AISI 316. Add 1 for screws or 2 for screws and pin.

For example: SKAC01-20Z2 for zinc coated steel, with screws and pin.

SKAC12

PIVOT PIN FOR SPHERICAL BEARING



STEEL

STAINLESS STEEL

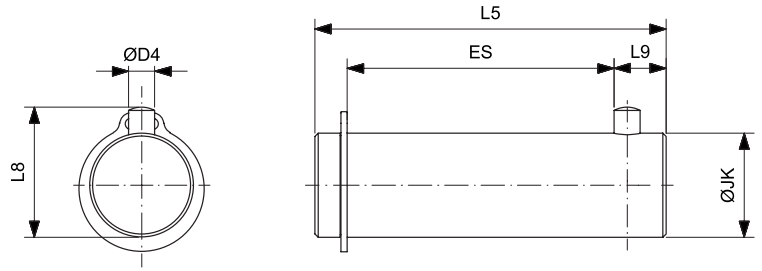

CODE	ØMM	ØD4	L8	ØJK	L5	L9	ES
SKAC12-32*	32	3	14	10	41	6.5	30.5
SKAC12-40*	40	4	16	12	48	8	36
SKAC12-50*	50	4	20	16	54	8	41
SKAC12-50*	63	4	20	16	60	8	47
SKAC12-80*	80	4	24	20	75	8	61
SKAC12-100*	100	4	24	20	85	8	71
SKAC12-125*	125	6	36	30	110	12	91

*While ordering, add Z for zinc coated steel version or X for stainless steel version
For example: SKAC01-20Z for zinc coated steel.

SKAC13

MALE HINGE, SPHERICAL BEARING

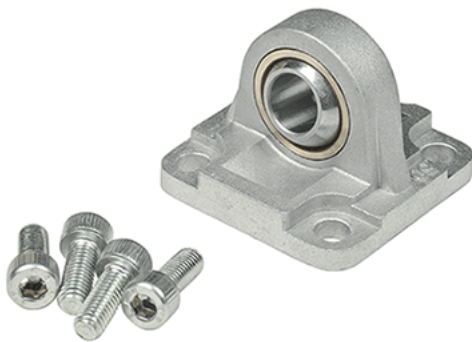

STEEL

STAINLESS STEEL

ALUMINIUM

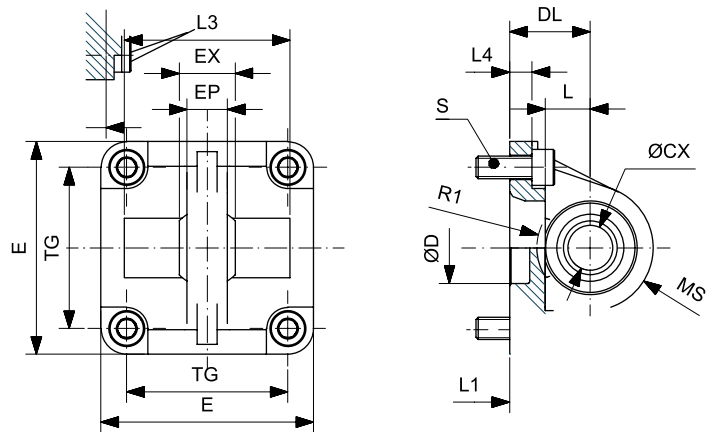

CODE	ØMM	TG	ØCX	DL	L	EX	EP	S	L4	D	L1	E	MS	L3	R1
SKAC13-32*	32	32.5	10	22	12	14	10.5	M6x20	5.5	30	7	45	16	-	-
SKAC13-40*	40	38	12	25	15	16	12	M6x20	5.5	35	7	52	18	-	-
SKAC13-50*	50	46.5	16	27	15	21	15	M8x20	6.5	40	7	65	21	51	19
SKAC13-63*	63	56.5	16	32	20	21	15	M8x20	6.5	45	7	75	23	-	-
SKAC13-80*	80	72	20	36	20	25	18	M10x25	10	45	9	95	28	74	24
SKAC13-100*	100	89	20	41	25	25	18	M10x25	10	55	9	115	30	140	32
SKAC13-125*	125	110	30	50	30	37	25	M12x25	10	60	9	140	40	-	-
SKAC13-160*	160	140	35	55	35	43	30	M16x30	10	65	7	180	44	-	-
SKAC13-200*	200	175	35	60	35	43	30	M16x30	11	75	7	220	47	220	48

*While ordering, add A for aluminium, Z for zinc coated steel or ZB for black painted steel. Add 1 for screws. For example: SKAC01-20Z1 for zinc coated steel.

SKAC14

SQUARE JOINT

STEEL

STAINLESS STEEL

ALUMINIUM

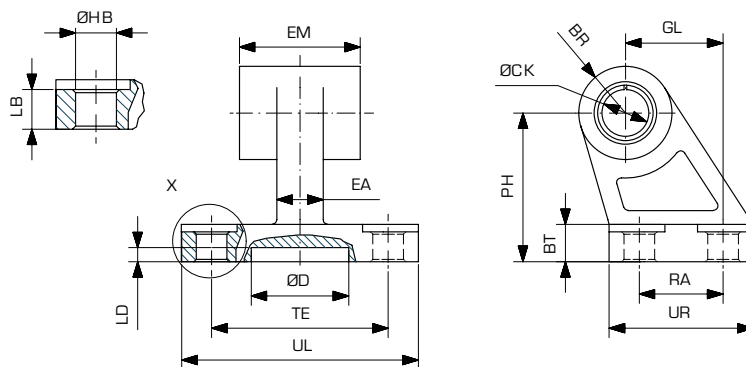

CODE	ØMM	ØCK	EM	BR	PH	GL	ØHB	LB	BT	TE	RA	ØD	LD	UL	UR	EA
SKAC14-32*	32	10	26	10	32	21	6.6	6.4	8	38	18	21	3	51	31	10
SKAC14-40*	40	12	28	11	36	24	6.6	8.4	10	41	22	21	3	54	35	15
SKAC14-50*	50	12	32	13	45	33	9	10.4	12	50	30	21	3	65	45	16
SKAC14-63*	63	16	40	15	50	37	9	12.4	14	52	35	21	3	67	50	16
SKAC14-80*	80	16	50	15	63	47	11	11.5	14	66	40	21	3	86	60	20
SKAC14-100*	100	20	60	19	71	55	11	14.5	17	76	50	11	3	96	70	20
SKAC14-125*	125	25	70	22.5	90	70	14	16.8	20	94	60	21	3	124	90	30
SKAC14-160*	160	30	90	31.5	115	97	14	21	25	118	88	31	5	156	126	36
SKAC14-200*	200	30	90	31.5	135	105	18	26	30	122	90	31	5	162	130	40

*While ordering, add A for aluminium, X for AISI 316, Z for zinc coated steel or ZB for black painted steel.
For example: SKAC01-20Z for zinc coated steel.

SKAC15

SQUARE JOINT, SPHERICAL HEAD

STEEL

STAINLESS STEEL

ALUMINIUM

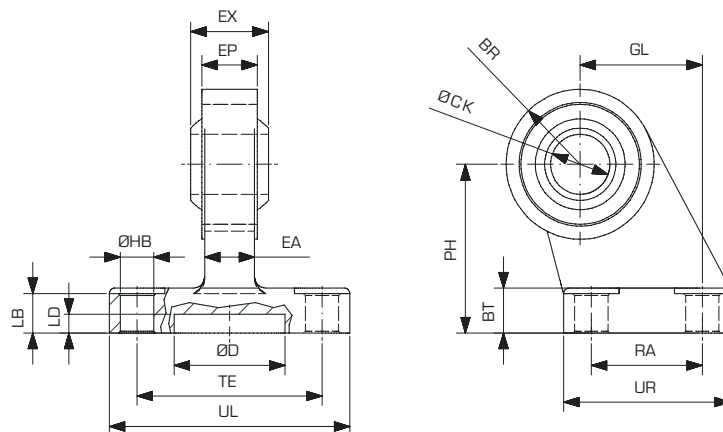

CODE	ØMM	ØHB	RA	UR	GL	BT	PH	TE	UL	BR	EP	ØCK	LB	ØD	LD	EA	EX
SKAC15-32*	32	6.6	18	31	21	10	32	38	51	15	10.5	10	8.5	20	5	8.5	14
SKAC15-40*	40	6.6	22	35	24	10	36	41	54	18	12	12	8.5	25	5	10	16
SKAC15-50*	50	9	30	45	33	12	45	50	65	20	15	16	10.5	30	5	13.5	21
SKAC15-63*	63	9	35	50	37	12	50	52	67	23	15	16	10.5	35	5	13.5	21
SKAC15-80*	80	11	40	60	47	14	63	66	86	27	18	20	11.5	45	5	15	25
SKAC15-100*	100	11	50	70	55	15	71	76	96	30	18	20	12.5	55	5	15	25
SKAC15-125*	125	13.5	60	90	70	20	90	94	124	40	25	30	17	65	7	20	37

*While ordering, X for AISI 316, Z for zinc coated steel or ZB for black painted steel.
For example: SKAC01-20Z for zinc coated steel.

SKAC16

LOW RISE PEDESTAL

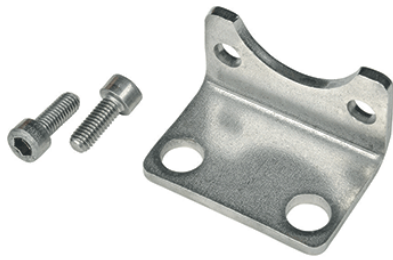

STEEL

STAINLESS STEEL

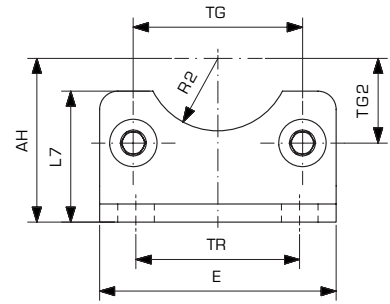
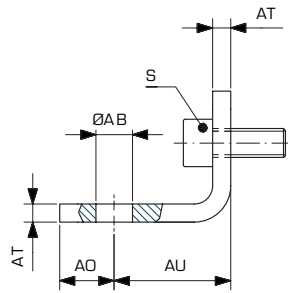

CODE	ØMM	TG	TG2	AH	R2	ØAB	AO	AU	TR	AT	S	L7	E
SKAC16-32*	32	32.5	16.25	32	15	7	11	24	32	4	M6X16	30	45
SKAC16-40*	40	38	19	36	17.5	10	8	28	36	4	M6X16	30	52
SKAC16-50*	50	46.5	23.25	45	20	10	15	32	45	5	M8X20	36	65
SKAC16-50*	63	56.5	28.25	50	22.5	10	13	32	50	5	M8X20	35	75
SKAC16-80*	80	72	36	63	22.5	12	14	41	63	6	M10X20	47	95
SKAC16-100*	100	89	44.5	71	27.5	14.5	16	41	75	6	M10X20	53	115
SKAC16-125*	125	110	55	90	30	16.5	25	45	90	8	M12X25	70	140
SKAC16-160*	160	140	70	115	32.5	18.5	15	60	115	10	M16X30	100	180
SKAC16-200*	200	175	87.5	135	37.5	24	30	70	135	12	M16X30	109	220

*While ordering, add Z for zinc coated steel or I for stainless steel version. For example: SKAC01-20Z for zinc coated steel. Add 1 for screws. For example: SKAC01-20Z1 for zinc coated steel, with screws.

SKAC17

FLANGE

STEEL

STAINLESS STEEL

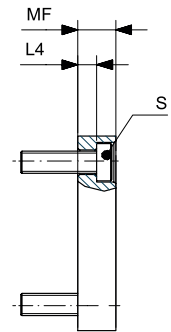
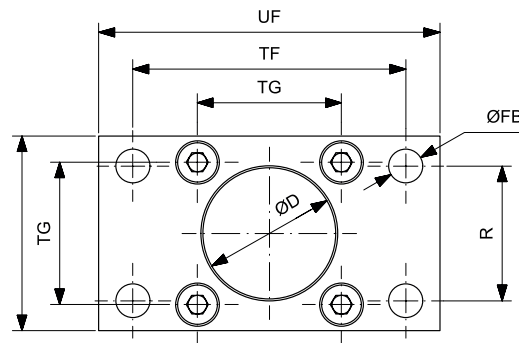
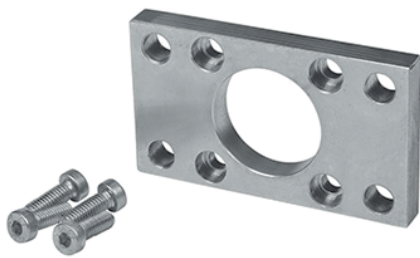

CODE	ØMM	TG	ØD	ØFB	R	TF	L4	S	UF	E	MF
SKAC17-32*	32	32.5	30	7	32	64	5	M6x20	80	45	10
SKAC17-40*	40	38	35	9	36	72	5	M6x20	90	52	10
SKAC17-50*	50	46.5	40	9	45	90	6.5	M8x20	110	65	12
SKAC17-50*	63	56.5	45	9	50	100	6.5	M8x20	120	75	12
SKAC17-80*	80	72	45	12	63	126	9	M10x25	150	95	16
SKAC17-100*	100	89	55	14	75	150	9	M10x25	170	115	16
SKAC17-125*	125	110	60	16	90	180	10.5	M12x25	205	140	20
SKAC17-160*	160	140	65	18	115	230	9.5	M16x30	260	180	20
SKAC17-200*	200	175	75	22	135	270	12.5	M16x30	300	220	25

*While ordering, add Z for zinc coated steel or I for stainless steel. Add 1 for screws. For example: SKAC01-20Z1 for zinc coated steel, with screws.

SKAC18

INTERMEDIATE HINGE FOR PROFILE CYLINDER

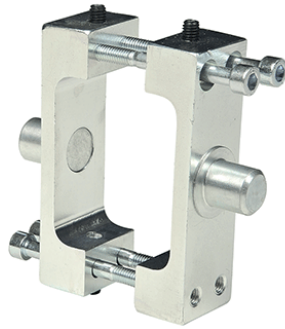

STEEL

STAINLESS STEEL

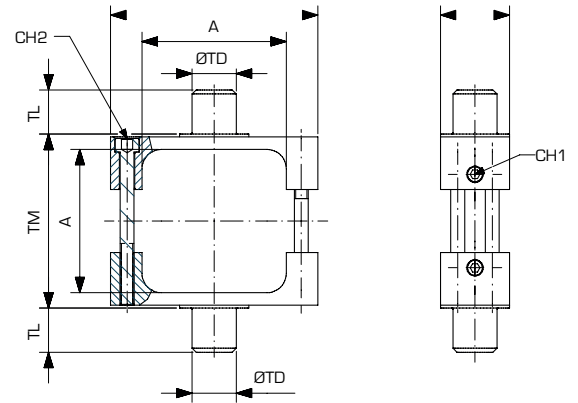

CODE	ØMM	A	TM	TL	TK	ØTD	UW	CH1	CH2
SKAC18-32*	32	45	50	11.5	25	12	65	3	3
SKAC18-40*	40	51.8	63	16	25	16	75	3	4
SKAC18-50*	50	60.7	75	16	30	16	95	3	5
SKAC18-63*	63	72.2	90	20	30	20	105	3	5
SKAC18-80*	80	91.2	110	20	30	20	130	3	5
SKAC18-100*	100	108.2	132	24.5	40	25	145	4	6
SKAC18-125*	125	135.3	160	24.5	40	25	176	4	6

*While ordering, add Z for zinc coated steel or X for AISI 316. Add 1 for screws.
For example: SKAC01-20Z1 for zinc coated steel, with screws.

SKAC19

INTERMEDIATE HINGE FOR TIE ROD CYLINDERS

STEEL

STAINLESS STEEL

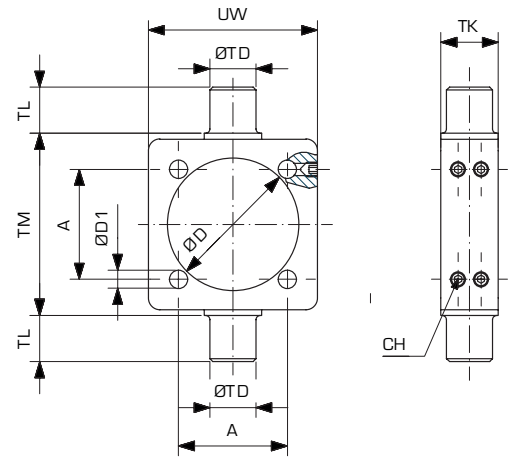
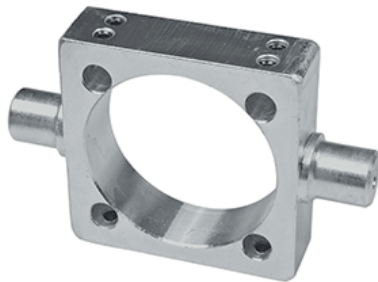

CODE	ØMM	A	TM	TL	TK	ØTD	ØD	ØD1	UW	CH	NUT*
SKAC19-32*	32	32.5	50	12	15	12	37	6.25	46	2.5	-
SKAC19-40*	40	38	63	16	20	16	46	6.25	59	2.5	-
SKAC19-50*	50	46.5	75	16	20	16	56	8.25	69	3	-
SKAC19-63*	63	56.5	90	20	25	20	69	8.25	84	3	-
SKAC19-80*	80	72	110	20	25	20	87	10.25	102	4	-
SKAC19-100*	100	89	132	25	30	25	107	10.25	125	4	-
SKAC19-125*	125	110	160	25	32	25	134	12.25	155	5	-
SKAC19-160*	160	140	200	32	40	32	171	16.25	190	-	M16X2
SKAC19-200*	200	175	250	32	40	32	214	16.25	240	-	M16X2

*While ordering, add Z for zinc coated steel, or X for AISI 316. Add 1 for screws. For example: SKAC01-20Z1 for zinc coated steel, with screws.
Note: it is possible to use the Ø160-200 intermediate hinge only combined with cylinders equipped with threaded tie rods.

SKAC19

INTERMEDIATE HINGE FOR TIE ROD CYLINDERS Ø25-320

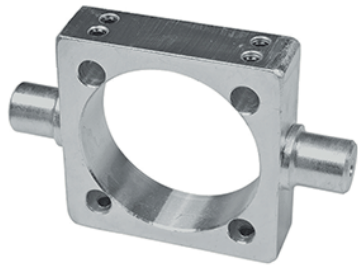

STEEL

STAINLESS STEEL

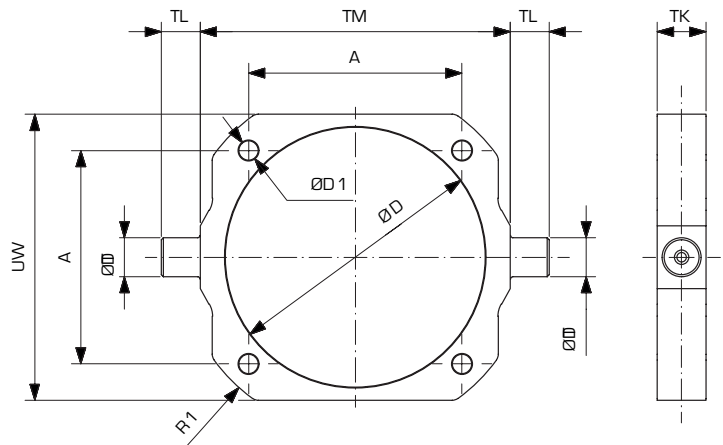

CODE	ØMM	A	TM	TL	TK	ØTD	ØD	ØD1	UW	R1	NUT
------	-----	---	----	----	----	-----	----	-----	----	----	-----

SKAC19-250*	250	220	320	40	50	40	264	20.25	295	180	M20X2.5
SKAC19-320*	320	270	400	50	70	50	338	24.25	370	220	M24X3

*While ordering, add Z for zinc coated steel. Add 1 for screws. For example: SKAC01-20Z1 for zinc coated steel, with screws. Note: it is possible to use the intermediate hinge only combined with cylinders equipped with threaded tie rods.

SKAC20

SUPPORT FOR INTERMEDIATE HINGE



STEEL

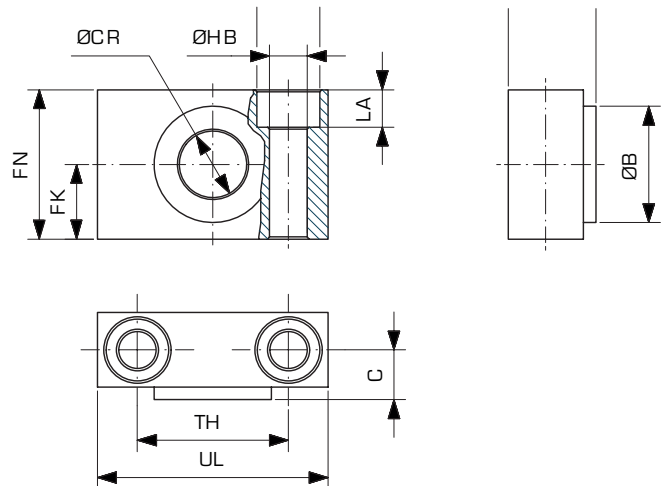

CODE	ØMM	ØCR	FN	FK	ØHB	ØA	LA	TH	C	UL	NH	ØB
------	-----	-----	----	----	-----	----	----	----	---	----	----	----

SKAC20-32*	32	12	30	15	6.6	11	7	32	10.5	46	18	22
SKAC20-40*	40-50	16	36	18	9	15	9	36	12	55	21	28
SKAC20-63*	63-80	20	40	20	11	18	11	42	13	65	23	32
SKAC20-100*	100-125	25	50	25	14	20	13	50	16	75	28.5	39
SKAC20-160*	160-200	32	60	30	18	26	17	60	22.5	92	40	45

*While ordering, add Z for zinc coated steel
For example: SKAC01-20Z for zinc coated steel.

SKAC21

FRONT/REAR TRUNNION

STEEL

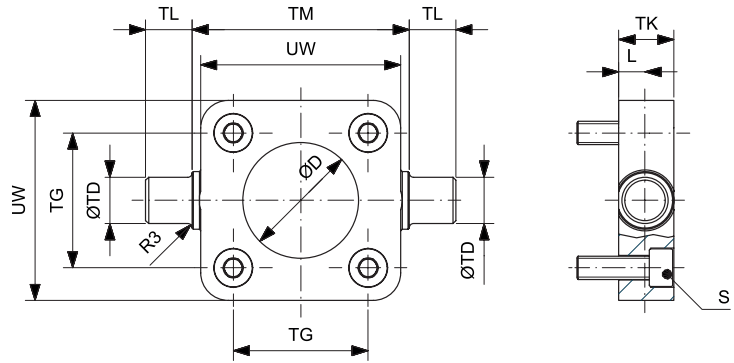
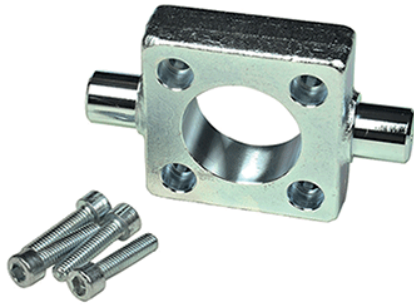

CODE	ØMM	TG	UW	TM	TL	ØTD	ØD	TK	R3	L	S
SKAC21-32*	32	32.5	46	50	12	12	30	14	1	6.5	M6X20
SKAC21-40*	40	38	59	63	16	16	35	19	1.5	9	M6X25
SKAC21-50*	50	46.5	69	75	16	16	40	19	1.6	9	M8X25
SKAC21-63*	63	56.5	84	90	20	20	45	24	1.6	11.5	M8X30
SKAC21-80*	80	72	102	110	20	20	45	24	1.6	11.5	M10X30
SKAC21-100*	100	89	125	132	25	25	55	29	2	14	M10X35
SKAC21-125*	125	110	150	160	25	25	60	30	2	15	M12X35
SKAC21-160*	160	140	180	200	32	32	65	40	2.5	20	M16X45
SKAC21-200*	200	175	250	250	32	32	75	40	2.5	20	M16X45

*While ordering, add Z for zinc coated steel. For example: SKAC01-20Z for zinc coated steel.

SKAC22

SK95 HINGE

STEEL

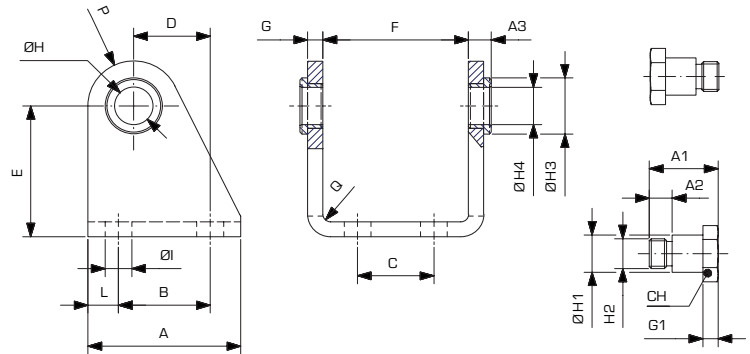
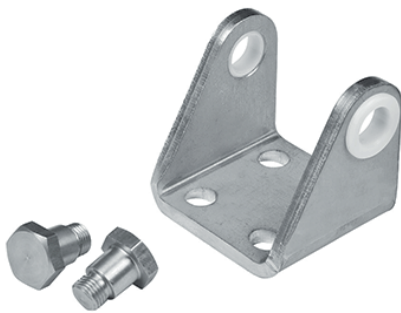

CODE	Ø	A	A1	A2	A3	B	C	D	E	F	G	G1	ØH	ØH1	H2	ØH3	ØH4	CH	ØI	L	P	Q
SKAC22-32*	32	40	18	6	6	24	20	20	35	38.1	4	4	12	10	M8x1	15	10	13	7	8	12	4
SKAC22-40*	40	50	21.6	7	7	30	28	27	40	46.1	5	5	15	12	M10x1	20	12	17	9	10	13	5
SKAC22-50*	50	54	26.4	9	8.5	34	36	30	45	57.1	6	6	18	14	M12x1,5	23	14	19	9	10	14	6
SKAC22-63*	63	65	31.5	13	8.5	35	42	34	50	70.1	6	6	20	16	M14x1,5	23	16	19	9	15	16	6

*While ordering, add Z for zinc coated steel or I for AISI 304. For example: SKAC01-20Z for zinc coated steel.

SKAC23

SK95 FOOT FLANGE

STEEL

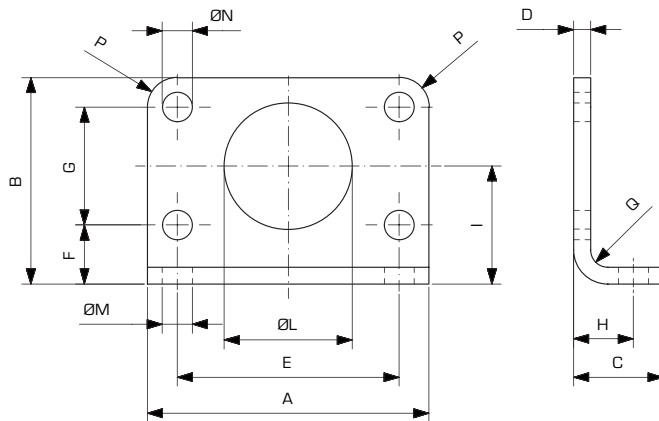
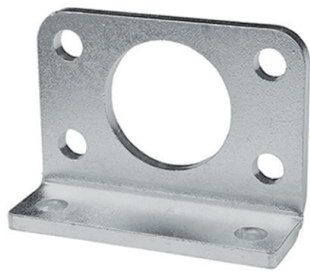

CODE	ØMM	A	B	C	D	E	F	G	H	I	ØL	ØM	ØN	P	Q
SKAC23-32*	32	66	49	21	4	52	14	28	14	28	30	7	7	7	4
SKAC23-40*	40	80	58	30	5	60	18	30	20	33	38	9	9	10	5
SKAC23-50*	50	90	70	30	6	70	20	40	20	40	45	9	9	10	6
SKAC23-63*	63	96	80	30	6	76	20	50	20	45	45	9	9	10	6

*While ordering, add Z for zinc coated steel or I for AISI 304. For example: SKAC01-20Z for zinc coated steel.

SKAC24

PINS FOR SK95 HINGE

STEEL

STAINLESS STEEL

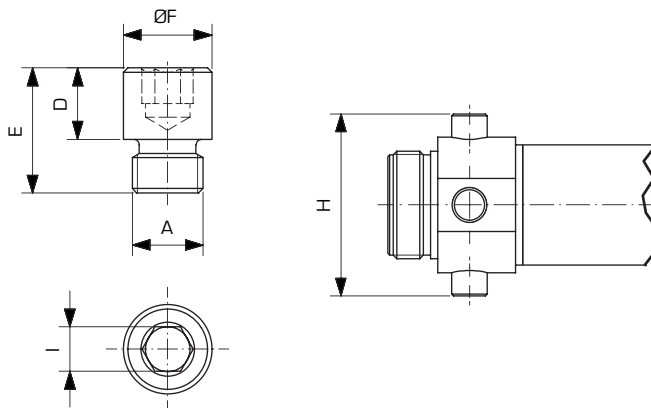

CODE	ØMM	A	D	E	ØF	I	H
SKAC24-32*	32	M8x1	8	14	10	5	51
SKAC24-40*	40	M10x1	9.5	16.5	12	6	61
SKAC24-50*	50	M12x1.5	11	20	14	6	75
SKAC24-63*	63	M14x1.5	13	28	16	8	92

*While ordering, add Z for zinc coated steel or I for AISI 304. For example: SKAC01-20Z for zinc coated steel.

SKAC27

INTERMEDIATE HINGE FOR TIE ROD CYLINDERS, THREADED

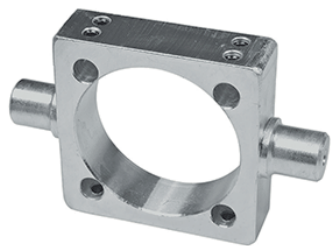

STEEL

STAINLESS STEEL

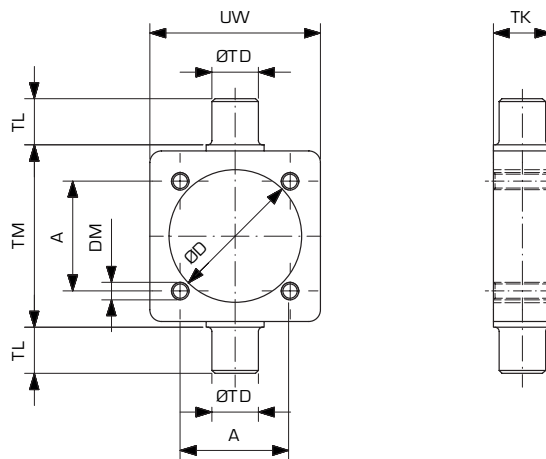

CODE	ØMM	A	TM	TL	TK	ØTD	ØD	ØD1	UW	CH
SKAC27-32*	32	32.5	50	12	15	12	37	M6	46	2.5
SKAC27-40*	40	38	63	16	20	16	46	M6	59	2.5
SKAC27-50*	50	46.5	75	16	20	16	56	M8	69	3
SKAC27-63*	63	56.5	90	20	25	20	69	M8	84	3
SKAC27-80*	80	72	110	20	25	20	87	M10	102	4
SKAC27-100*	100	89	132	25	30	25	107	M10	125	4
SKAC27-125*	125	110	160	25	32	25	134	M12	155	5
SKAC27-160*	160	140	200	32	40	32	171	M16	190	-
SKAC27-200*	200	175	250	32	40	32	214	M16	240	-

*While ordering, add Z for zinc coated steel, for stainless steel

SKAC30

SLOTTED NUT

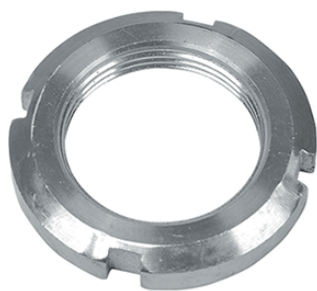

STEEL

STAINLESS STEEL

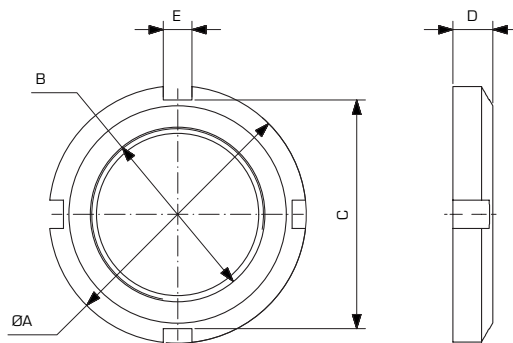

CODE	A	B	C	D	E
SKAC30-32*	45	M30x1.5	40	7	5
SKAC30-40*	50	M38x1.5	46	8	5
SKAC30-5063*	58	M45x1.5	52	9	6

*While ordering, add Z for zinc coated steel or I for stainless steel

SKAC31

2-WIRE REED MAGNETIC SENSORS



NOTE: SCREW CLAMP VERSION DISPLAYED

TECHNICAL FEATURES

PRODUCT CODE

SKAC31-S2-M8-3M

HOUSING MATERIAL

PA6

OPERATING VOLTAGE

10 - 240 V AC/DC

MAXIMUM LOAD

10 W DC

MAX CURRENT

400 mA at 25° C

LOGIC

PNP

PROTECTION CLASS

EN 60529 (DIN 40050) - IP67

INDICATOR LIGHT

Yellow LED

LOCKING SYSTEM

Snap clamping for easy assembly

CABLE LENGTH

3 meter

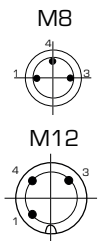
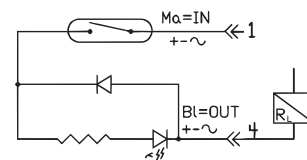
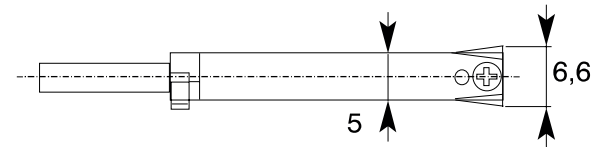
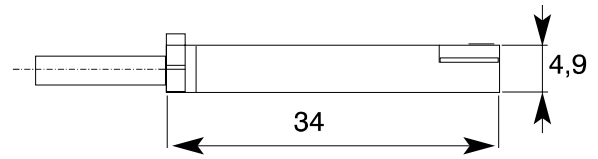

Other configurations are available upon request.