

Modular F.R.L. Units

RoHS

Modular Design with Uniform Body Style

Better visibility & environmental resistance



The bowl is covered with a transparent bowl guard!

* Body sizes 30 and larger

- The inside is visible from 360°.
- The inner bowl is protected from the environment, allowing for improved safety.

- Inner bowl**
Material: Polycarbonate
- Transparent bowl guard**
Material: Polycarbonate



New A right angle square type pressure gauge and various attachments have been added.

Right Angle Square Type Pressure Gauge **p. 8**

Allows for pressure confirmation from the knob side

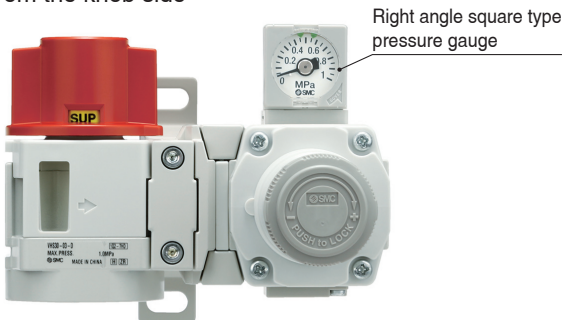

Cross Adapter **p. 9**

Allows for devices to be connected on the top, bottom, left, and right

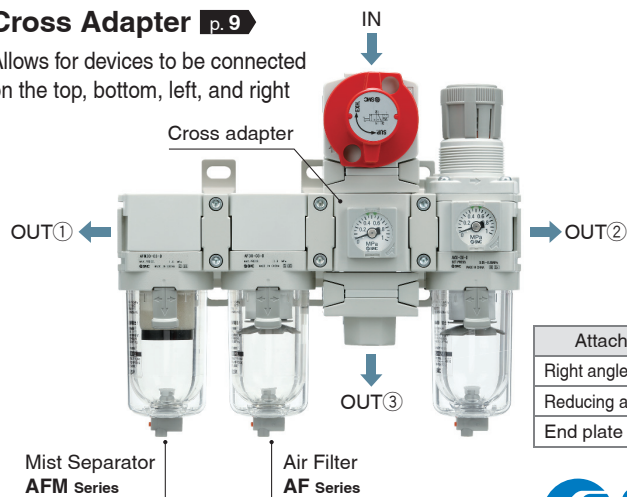

Attachment	Page
Right angle adapter	7
Reducing adapter	10
End plate	70

AC Series



Mist Separator **AFM20-D to AFM40-D Series**

Micro Mist Separator **AFD20-D to AFD40-D Series**

Standard Specifications

Model	AFM20-D/AFD20-D	AFM30-D/AFD30-D	AFM40-D/AFD40-D	AFM40-06-D/AFD40-06-D
Port size	1/8, 1/4	1/4, 3/8	1/4, 3/8, 1/2	3/4
Fluid	Air			
Ambient and fluid temperatures	-5 to 60 °C (No freezing)			
Proof pressure	1.5 MPa			
Max. operating pressure	1.0 MPa			
Min. operating pressure	0.05 MPa			
Auto drain minimum operating pressure	N.C.	0.1 MPa	0.15 MPa	0.15 MPa
	N.O.	—	—	0.1 MPa
Max. flow capacity*1	[AFM]	200 l/min (ANR)	450 l/min (ANR)	1100 l/min (ANR)
	[AFD]	120 l/min (ANR)	240 l/min (ANR)	600 l/min (ANR)
Nominal filtration rating*2	[AFM]	0.3 μm (Filtration efficiency 99.9 %)		
	[AFD]	0.01 μm (Filtration efficiency 99.9 %)		
Outlet side oil mist concentration*3, *4	[AFM]	Max. 1.0 mg/m ³ (≈ 0.8 ppm)		
	[AFD]	Max. 0.1 mg/m ³ (Before saturated with oil 0.01 mg/m ³ or less ≈ 0.008 ppm)		
Compressed air purity class*5	[AFM]	ISO 8573-1:2010 [3 : 7 : 3]*6		
	[AFD]	ISO 8573-1:2010 [1 : 7 : 2]*7		
Drain capacity	8 cm ³	25 cm ³	45 cm ³	45 cm ³
Bowl material	Polycarbonate			
Bowl guard	Semi-standard (Steel)	Standard (Polycarbonate)		
Weight	0.10 kg	0.18 kg	0.37 kg	0.40 kg

- *1 Inlet pressure: 0.7 MPa. Flow at 20 °C, atmospheric pressure, and 65 % of the relative humidity. The maximum flow capacity varies depending on the inlet pressure. Keep the air flow within the maximum flow capacity to prevent an outflow of lubricant to the outlet side.
- *2 For the following conditions in accordance with [Test condition: ISO 8573-4:2001, Test method ISO 12500-3:2009 compliant] in addition to the conditions above. Conditions: When a new element is used, and the flow capacity, inlet pressure, and the amount of solid bodies on the filter inlet side are stable.
- *3 The outlet side oil mist concentration for the following conditions in accordance with [Test condition:

- ISO 8573-2:2007, Test method ISO 12500-1:2007 compliant] in addition to the conditions above. Conditions: When a new element is used, the oil mist concentration on the filter inlet side is 10 mg/m³, and the flow capacity, inlet pressure, and the oil mist concentration on the filter inlet side are stable.
- *4 The bowl seal and other O-rings are slightly lubricated.
- *5 The compressed air purity class is indicated based on ISO 8573-1:2010 Compressed air – Part 1: Contaminants and purity classes. For details on this standard, refer to page 131.
- *6 The compressed air quality class on the inlet side is [6 : 8 : 4].
- *7 The compressed air quality class on the inlet side is [3 : 7 : 3].

Bowl Assembly/Part Nos.

Bowl material	Drain discharge mechanism	Drain port	Other	Model			
				AFM20-D/AFD20-D	AFM30-D/AFD30-D	AFM40-D/AFD40-D	AFM40-06-D/AFD40-06-D
Polycarbonate	Manual	With drain cock	—	C2SF-D	—	—	—
		Drain cock with barb fitting	With bowl guard	C2SF-C-D	C3SF-D	—	C4SF-D
		With drain guide (without valve function)	With bowl guard	C2SF-W-D	C3SF-W-D	—	C4SF-W-D
	Automatic*1 (Auto drain)	Normally closed (N.C.)	—	C2SF□-J-D	—	—	—
		Normally open (N.O.)	With bowl guard	C2SF□-CJ-D	C3SF□-J-D	—	C4SF□-J-D
		Normally open (N.O.)	With bowl guard	AD27-D	—	—	—
Nylon	Manual	With drain cock	—	AD27-C-D	AD37□-D	—	AD47□-D
		Drain cock with barb fitting	With bowl guard	—	AD38□-D	—	AD48□-D
		With drain guide (without valve function)	With bowl guard	C2SF□-6J-A	—	—	—
	Automatic*1 (Auto drain)	Normally closed (N.C.)	—	AD27-6-A	—	—	—
		Normally open (N.O.)	With bowl guard	AD27-6C-A	AD37□-6-A	—	AD47□-6-A
		Normally open (N.O.)	With bowl guard	—	AD38□-6-A	—	AD48□-6-A
Metal	Manual	With drain cock	—	C2SF-2-A	C3SF-2-A	—	C4SF-2-A
		With drain guide (without valve function)	With level gauge	—	C3LF-8-A	—	C4LF-8-A
		With drain guide (without valve function)	With level gauge	C2SF□-2J-A	C3SF□-2J-A	—	C4SF□-2J-A
	Automatic*1 (Auto drain)	Normally closed (N.C.)	—	AD27-2-A	AD37□-2-A	—	AD47□-2-A
		Normally open (N.O.)	With level gauge	—	AD37□-8-A	—	AD47□-8-A
		Normally open (N.O.)	With level gauge	—	AD38□-2-A	—	AD48□-2-A
Normally open (N.O.)	With level gauge	—	AD38□-8-A	—	AD48□-8-A		

- *1 The bowl assembly comes with a bowl seal. □ in bowl assembly part numbers indicates a pipe thread type (applicable tubing for auto drain). No indication is necessary for Rc thread; however, indicate N for NPT thread, and F for G thread. (For auto drain, —: O 10, N: O 3/8") Please contact SMC separately for psi and °F unit display specifications.

Option/Part Nos.

Optional specifications	Model			
	AFM20-D/AFD20-D	AFM30-D/AFD30-D	AFM40-D/AFD40-D	AFM40-06-D/AFD40-06-D
Bracket assembly*1	AF24P-070AS	AF34P-070AS	AF44P-070AS	AF49P-070AS
Auto drain	Refer to "Bowl Assembly/Part Nos."			

- *1 The assembly consists of a bracket A/B and 2 mounting screws.

Replacement Parts

Description	Part no.			
	AFM20-D/AFD20-D	AFM30-D/AFD30-D	AFM40-D/AFD40-D	AFM40-06-D/AFD40-06-D
Element assembly	AFM20P-060AS	AFM30P-060AS	AFM40P-060AS	AFM40-06P-060AS
Bowl seal	C2SFP-260S	C32FP-260S	C42FP-260S	C42FP-260S
Bowl assembly*1, *2	Refer to "Bowl Assembly/Part Nos."			

- *1 The bowl assembly comes with a bowl seal.
*2 Please contact SMC separately for psi and °F unit display specifications.

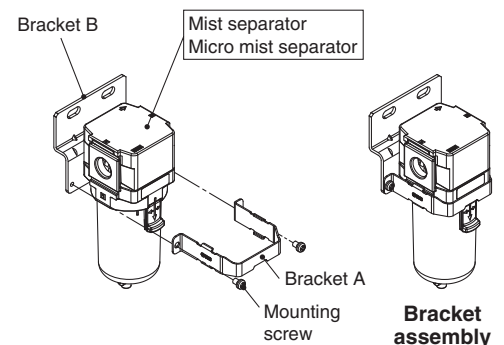

AFM20-D to AFM40-D Series

AFD20-D to AFD40-D Series

Flow Rate Characteristics (Representative values)

--- Initial state

AFM20-D

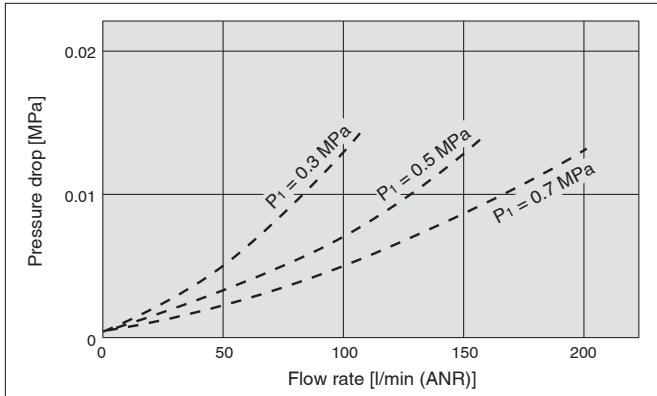

AFD20-D

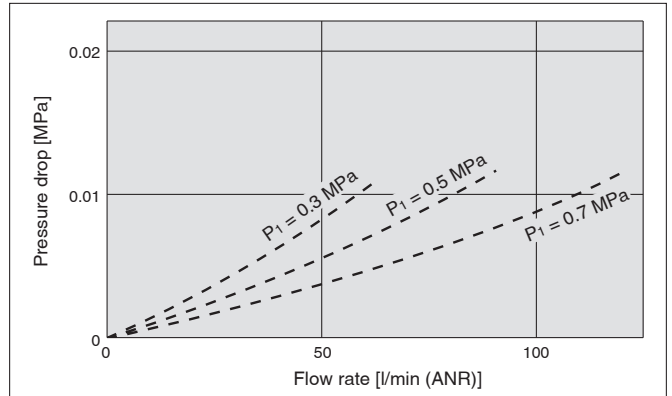

AFM30-D

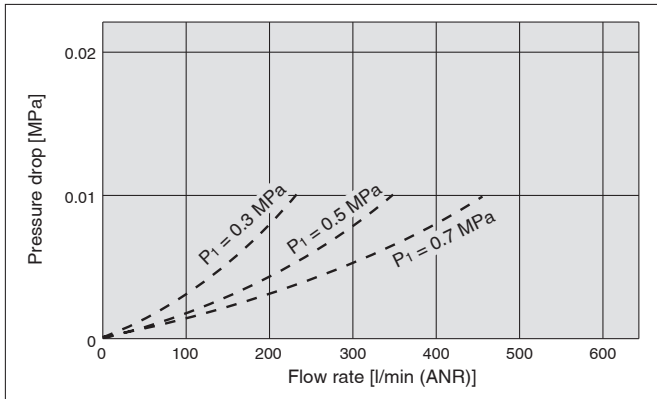

AFD30-D

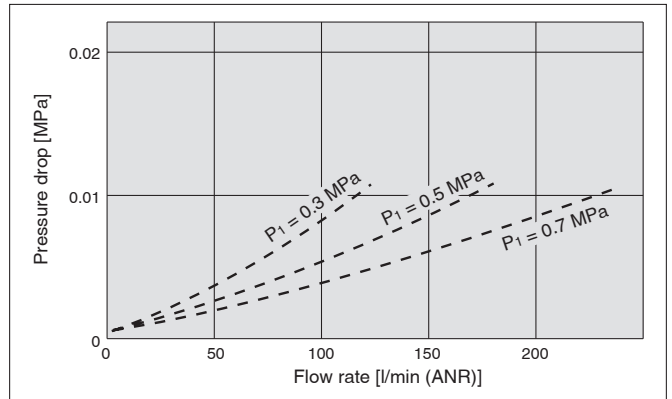

AFM40-D

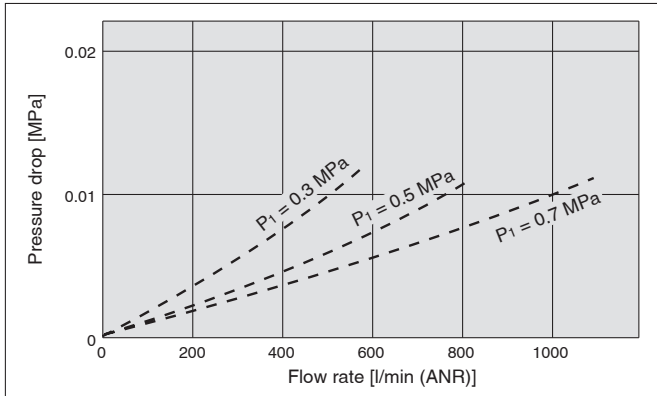

AFD40-D

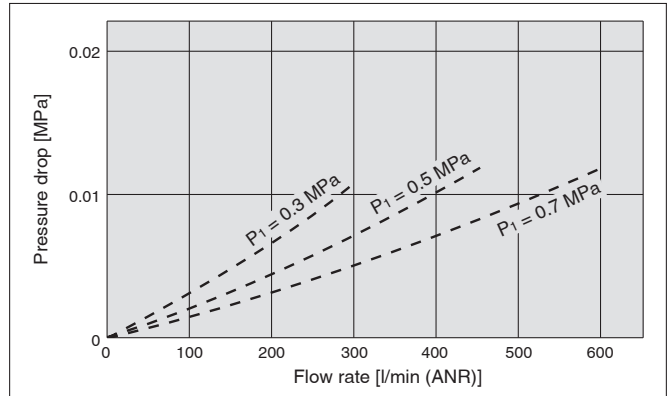

Mist Separator **AFM20-D to AFM40-D Series**

Micro Mist Separator **AFD20-D to AFD40-D Series**

Dimensions

AFM20-D
AFD20-D

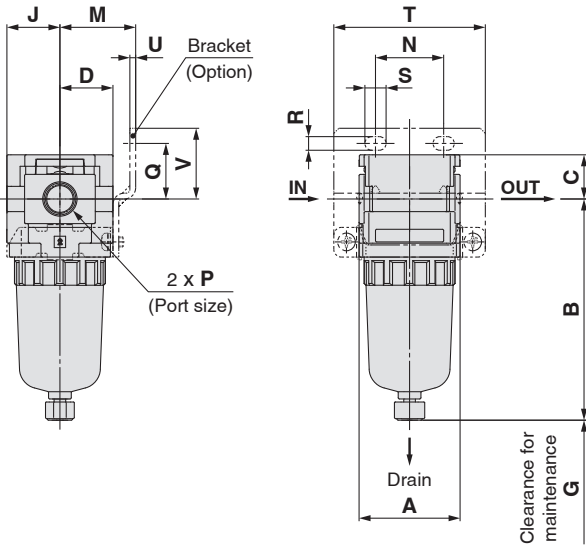

AFM30-D to AFM40-06-D
AFD30-D to AFD40-06-D

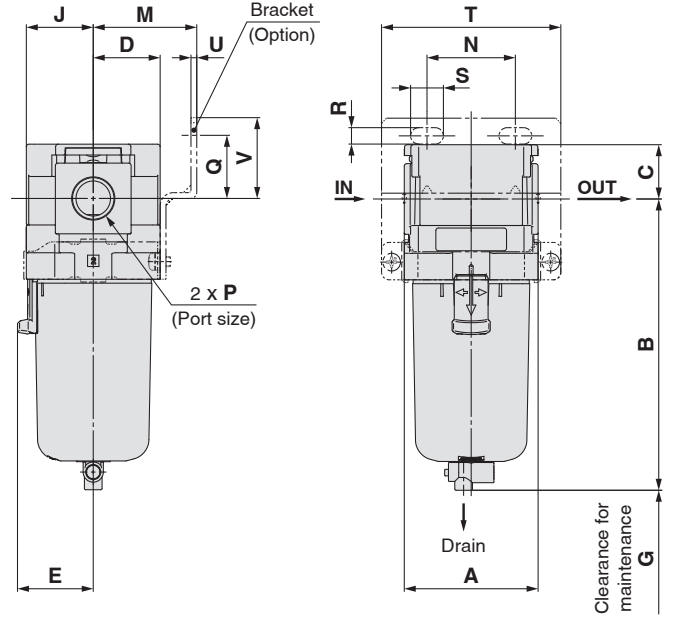

Applicable model	Optional specifications		Semi-standard					
	With auto drain	PC/PA bowl		Metal bowl		Metal bowl with level gauge		With element service indicator
		Drain cock with barb fitting	With drain guide	With drain cock	With drain guide	With drain cock	With drain guide	
AFM20-D AFD20-D								
AFM30-D to AFM40-06-D AFD30-D to AFD40-06-D	N.O.: Black N.C.: Grey Thread type/Rc, G: O 10 One-touch fitting Thread type/NPT: O 3/8" One-touch fitting							

Model	Standard specifications																Optional specifications		
																	Bracket mount		With auto drain
	P	A	B	C	D	E	G	J	M	N	Q	R	S	T	U	V	B		
AFM20-D/AFD20-D	1/8, 1/4	40	87.6	17.5	21	—	45	21	30	27	22	5.4	8.4	60	2.3	28	104.9		
AFM30-D/AFD30-D	1/4, 3/8	53	115.4	21.5	26.5	30	50	26.5	41	35	25	6.5	13	71	2.3	32	157.1		
AFM40-D/AFD40-D	1/4, 3/8, 1/2	70	147.1	25.5	35.5	38.4	75	35.5	50	52	30	8.5	12.5	88	2.3	39	186.9		
AFM40-06-D/AFD40-06-D	3/4	75	149.1	27	35.5	38.4	75	35.5	50	52	34	8.5	12.5	88	2.3	43	188.9		

Model	Semi-standard specifications						
	PC/PA bowl		Metal bowl		Metal bowl with level gauge		With element service indicator
	With barb fitting	With drain guide	With drain cock	With drain guide	With drain cock	With drain guide	
	B	B	B	B	B	B	C1
AFM20-D/AFD20-D	—	91.4	87.4	93.9	—	—	50.6
AFM30-D/AFD30-D	123.9	122.2	117.8	122.3	137.8	142.3	54.3
AFM40-D/AFD40-D	155.6	153.9	149.5	154	169.5	174	58.3
AFM40-06-D/AFD40-06-D	157.6	155.9	151.5	156	171.5	176	—

Mist Separator/AFM20-D to AFM40-06-D Micro Mist Separator/AFD20-D to AFD40-06-D Made to Order

Please contact SMC for detailed dimensions, specifications, and lead times.



① Long Bowl

Drain capacity is greater than that of standard models.

Applicable Models/Drain Capacity

Model	AFM20-D/AFD20-D	AFM30-D/AFD30-D	AFM40-D/AFD40-D	AFM40-06-D/AFD40-06-D
Port size	1/8, 1/4	1/4, 3/8	1/4, 3/8, 1/2	3/4
Drain capacity [cm ³]	19	43	88	
B dimension [mm] ^{*1}	108.1	137.4	167.2	169.2

*1 For polycarbonate bowls. Please contact SMC for other bowl materials.

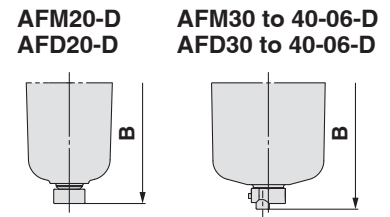
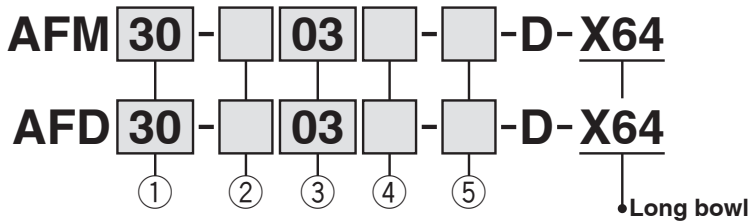

Semi-standard Symbol Selection

- Select one each for a to d.
 - When more than one specification is required, indicate in alphanumeric order.
- Example) AFM30-F03B-2JR-D-X64

		Symbol	Description	① Body size			
				20	30	40	
②	Pipe thread type	—	Rc	●	●	●	
		N	NPT	●	●	●	
		F	G	●	●	●	
		+					
③	Port size	01	1/8	●	—	—	
		02	1/4	●	●	●	
		03	3/8	—	●	●	
		04	1/2	—	—	●	
		06	3/4	—	—	●	
		+					
④	Option (Mounting)	—	Without mounting option	●	●	●	
		B ^{*1}	With bracket	●	●	●	
		+					
⑤	a	Bowl ^{*2}	—	Polycarbonate bowl	●	●	●
			2	Metal bowl	●	●	●
			6	Nylon bowl	●	●	●
			C	With bowl guard	●	— ^{*3}	— ^{*3}
			6C	With bowl guard (Nylon bowl)	●	— ^{*4}	— ^{*4}
			+				
	b	Drain port	—	With drain cock	●	●	●
			J ^{*5}	Drain guide 1/8	●	—	—
			W ^{*6}	Drain cock with barb fitting	—	●	●
			+				
c	Flow direction	—	Flow direction: Left to right	●	●	●	
		R	Flow direction: Right to left	●	●	●	
		+					
d	Unit	—	Unit on product label: MPa, °C	●	●	●	
		Z ^{*7}	Unit on product label: psi, °F	○ ^{*8}	○ ^{*8}	○ ^{*8}	

*1 Option B is included in the package with the product but does not come assembled. The assembly consists of 2 types of the bracket and 2 mounting screws.

*2 Refer to chemical data on page 91 for chemical resistance of the bowl.

*3 A bowl guard is provided as standard equipment (polycarbonate).

*4 A bowl guard is provided as standard equipment (nylon).

*5 Without a valve function. The mounting screws are the same as the thread of ②.

*6 The combination of metal bowl 2 is not available.

*7 For the pipe thread type: NPT. This product is for overseas use only according to the New Measurement Act. (The SI unit type is provided for use in Japan.)

*8 ○: For the pipe thread type: NPT only

Mist Separator/*AFM20-D to AFM40-06-D* Micro Mist Separator/*AFD20-D to AFD40-06-D* Made to Order



② Clean Series

For details, refer to the Clean Series/Low Particle Generation section of the **Web Catalogue**.

10 - Standard model no.

• Clean Series

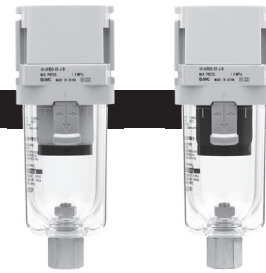

10-AFM

10-AFD

③ Copper, Fluorine and Silicone-free + Low Particle Generation

For details, refer to the Clean Series/Low Particle Generation section of the **Web Catalogue**.

21 - Standard model no.

• Copper, Fluorine and Silicone-free + Low Particle Generation



AFM-D/AFD-D Series Specific Product Precautions

Be sure to read this before handling the products. Refer to the back cover for safety instructions. For F.R.L. units precautions, refer to the “Handling Precautions for SMC Products” and the “Operation Manual” on the SMC website: <https://www.smc.eu>

Design / Selection

Warning

1. The bowl material of the standard mist separator and micro mist separator is polycarbonate. Do not use in an environment where they are exposed to or come in contact with organic solvents, chemicals, cutting oil, synthetic oil, alkali, and thread lock solutions.

Chemical resistance of polycarbonate or nylon bowl

Type	Chemical name	Application examples	Material	
			Polycarbonate	Nylon
Acid	Hydrochloric acid Sulfuric acid Phosphoric acid Chromic acid	Acid washing liquid for metals	△	×
Alkaline	Sodium hydroxide (Caustic soda) Potash Calcium hydroxide (Slack lime) Ammonia water Sodium carbonate	Degreasing of metals Industrial salts Water-soluble cutting oil	×	○
Inorganic salts	Sodium sulfide Potassium nitrate Sodium sulfate	—	×	△
Chlorine solvents	Carbon tetrachloride Chloroform Ethylene chloride Methylene chloride	Cleansing liquid for metals Printing ink Dilution	×	△
Aromatic series	Benzene Toluene Paint thinner	Coatings Dry cleaning	×	△
Ketone	Acetone Methyl ethyl ketone Cyclohexane	Photographic film Dry cleaning Textile industries	×	×
Alcohol	Ethyl alcohol IPA Methyl alcohol	Antifreeze Adhesives	△	×
Oil	Gasoline Kerosene	—	×	○
Ester	Phthalic acid dimethyl Phthalic acid diethyl Acetic acid	Synthetic oil Anti-rust additives	×	○
Ether	Methyl ether Ethyl ether	Brake oil additives	×	○
Amino	Methyl amino	Cutting oil Brake oil additives Rubber accelerator	×	×
Others	Thread-lock fluid Seawater Leak tester	—	×	△

○: Essentially safe △: Some effects may occur. ×: Effects will occur.

* When the above factors are present, or there is some doubt, use a metal bowl for safety.

* The display window material for the semi-standard type with an element service indicator is nylon.

Air Supply

Caution

1. Install an air filter (AF series) as a pre-filter on the inlet side of the mist separator to prevent premature clogging.
2. Install a mist separator (AFM series) as a pre-filter on the inlet side of the micro mist separator to prevent premature clogging.
3. Do not install on the inlet side of the dryer as this can cause premature clogging of the element.

Maintenance

Warning

1. Replace the element every 2 years or when the pressure drop becomes 0.1 MPa, whichever comes first, to prevent damage to the element.

Mounting / Adjustment

Caution

1. When the bowl is installed on the mist separator (AFM30-D/AFM40-D), or micro mist separator (AFD30-D/AFD40-D), install them so that the lock button lines up to the groove of the front (or the back) of the body to avoid drop or damage of the bowl.

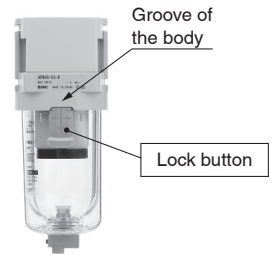

Design

Caution

1. Design the system so that the mist separator or micro mist separator is installed in a pulsation-free location. The difference between internal and external pressure inside the element should be kept within 0.1 MPa, as exceeding this value could cause damage.

Selection

Caution

1. Do not allow air flow that exceeds the rated flow. If the air flow is allowed outside the range of the rated flow even momentarily, drainage and lubricant may splash at the outlet side or cause damage to the component.
2. Do not use in a low pressure application (such as a blower). An F.R.L. unit has its own minimum operating pressure depending on the equipment and is designed specifically to function with compressed air. If used below the minimum operating pressure, a loss of performance and malfunction can occur. Please contact SMC if an application under such conditions cannot be avoided.

Handling

Caution

1. The element service indicator (Semi-standard: L) is used to check the pressure differential between the IN and OUT sides. When operating at a flow rate with a pressure differential exceeding 0.025 MPa, the element service indicator may operate even when the element is in its initial state.
2. For models with an element service indicator, adjust the flow rate in the direction that increases the flow rate. If the designated flow rate is exceeded, reset the flow rate to zero and readjust it until the designated flow rate is reached.
3. For models with an element service indicator, as the element becomes more clogged, the indicator will display an increasing level of red. Be sure to replace the element before the level of red reaches the top of the indicator.