

Media: air - water  
 Pressure range: 0 to 10 Bar max  
 Media temp: -15°C to +100°C max  
 Ambient temperature: -15°C to +50°C  
 Media viscosity: 500 centistokes max  
 Duty cycle: 100,000  
 Mounting: Any  
 Seals: PTFE + EPDM  
 WRAS certificate no: 2010303

# Actuated WRAS Ball Valve

1/4 – 1

Failsafe + Power Open/Close

0 – 10 Bar

TYPE ABVM/AR



## PRESSURE

Ø Port BSP	Orifice mm	Operating Time Seconds	Pressure Rating (Bar) ΔP		Voltage	Part Number
			Min	Max		
1/4	8	5	0	10	9 to 24v AC or DC	ABVM02S/9AR + option
					110 to 240vAC	ABVM02S/2AR + option
3/8	10	5	0	10	9 to 24v AC or DC	ABVM03S/9AR + option
					110 to 240vAC	ABVM03S/2AR + option
1/2	15	5	0	10	9 to 24v AC or DC	ABVM04S/9AR + option
					110 to 240vAC	ABVM04S/2AR + option
3/4	20	5	0	10	9 to 24v AC or DC	ABVM06S/9AR + option
					110 to 240vAC	ABVM06S/2AR + option
1	25	5	0	10	9 to 24v AC or DC	ABVM08S/9AR + option
					110 to 240vAC	ABVM08S/2AR + option

## OPTIONS

Visual Position Indication, Failsafe Closed 2 wire (+AR) or Failsafe Open 2 wire (+AR-NO)  
 Manual Override (Lift + Turn +MO) 9-24 volt only. (Not IP67)  
 Power Open / Power Close, 2 wire + 1 control wire  
 Fully Open + Closed volt free position feedback switches (+E2), Rated 0 to 36vDC 0.4 Amp Max  
 Sun and rain protection cover  
 316 Stainless, PVC, 3-piece, 3 way & Brass Ball Valves, longer lead wire, different voltage and more

## ELECTRICAL DATA

Voltage Min - Max Continuous Duty 100%	Actuator		Power		Enclosure	Electrical connections
	Model	Torque	Moving	Holding		
9 to 24 volts AC 50/60Hz or DC	ABVM	2 Nm	5 Watts	0.22 Watts	IP67	0.5 meter lead wires
110 to 240 volts AC 50/60Hz				0.6 Watts		

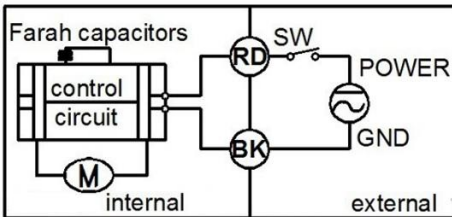

**Failsafe Control.**  
 Power ON motor actuates valve into powered position and then automatically powers off. Valve stays in powered position.  
 Power OFF motor actuates valve back to start position using reserve power. Valve stays in start position.  
**Failsafe requires 10-15 seconds Power On to Recharge the Farah capacitors.**

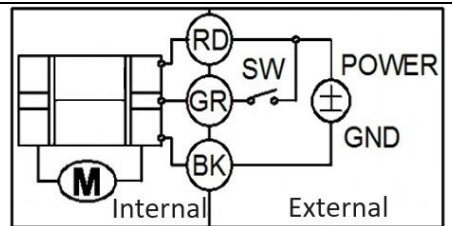
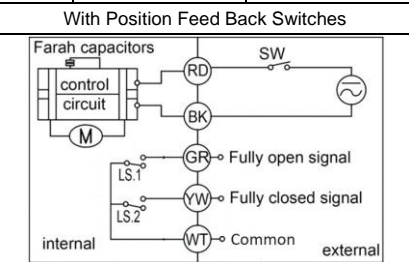

**3 Wire Control**  
 Power ON to GREEN motor actuates valve into powered position and then automatically powers off. Valve stays in powered position.  
 Power OFF to GREEN motor actuates valve back to start position and then automatically powers off. Valve stays in start position.

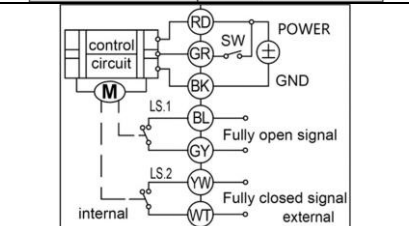

## CONSTRUCTION

Valve Body: 304 stainless steel static test pressure 35 Bar.  
 Seals: Stem 2x EPDM, Ball WRAS EPDM + PTFE Floating no leakage design  
 ABVM Actuator: ABS Engineering Plastic, Gears: Metal, Factory function test 200 cycles Open/Close

## OVERALL DIMENSIONS

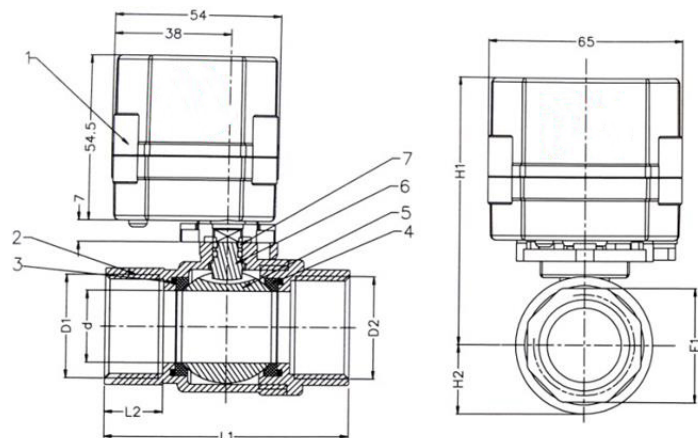

Port D1/D2	d	L1	L2	E1	H1	H2	Kg
1/4	8	49	12	20.5	69	12	0.3
3/8	10	49	12	20.5	69	12	0.4
1/2	15	63	14	25	83	17	0.4
3/4	20	72	17	31	87	20	0.5
1	25	81	18	38	95	24	0.7

Ref	Description	Material
1	Actuator	ABS
2	Body Cover	SS304
3	O Ring	EPDM
4	Sealing	PTFE/EPDM
5	Ball	SS304
6	Stem	SS304
7	O Ring	EPDM